

M5210 series

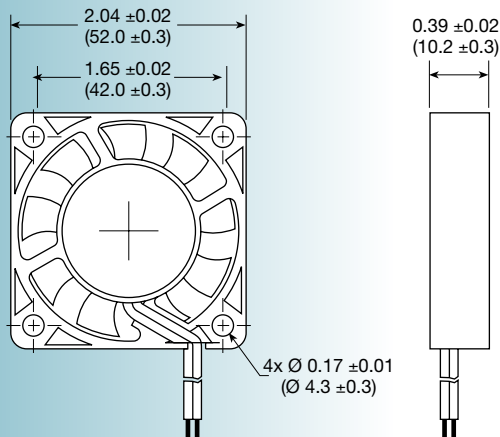

Size: (52 x 52 x 10 mm)
2.04 x 2.04 x 0.39 inches

- Construction:** UL94V-0 PBT impeller & frame
- Bearing option:** ball bearing or sleeve
- Connection:** AWG 26, UL1007 lead wires
- Frame:** ribbed
- Protection:** impedance
- Options:** tachometer output signal

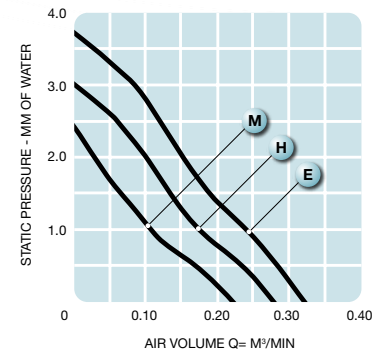

Model No.	Rated Voltage V	Operating Voltage V	Current mA	Revolution RPM	Air Volume		Max. Static Pressure (H ₂ O)		Sound Noise dbA	Weight g
					M ³ /Min.	CFM	MM	INCH		
M5210M	5	3 - 6.0	80	4,000	0.22	7.77	2.40	0.10	24	20
M5210H	5	3 - 6.0	160	5,000	0.28	9.89	3.00	0.12	26	20
M5210M	12	7- 13.8	70	4,000	0.22	7.77	2.40	0.10	24	20
M5210H	12	7- 13.8	100	5,000	0.28	9.89	3.00	0.12	26	20
M5210E	12	7- 13.8	120	6,000	0.32	11.30	3.70	0.15	28	20