

LTR	REVISION	DATE	APPD
C	050919-GP01: ADDED O-RING MATERIAL	05-10-19	GP

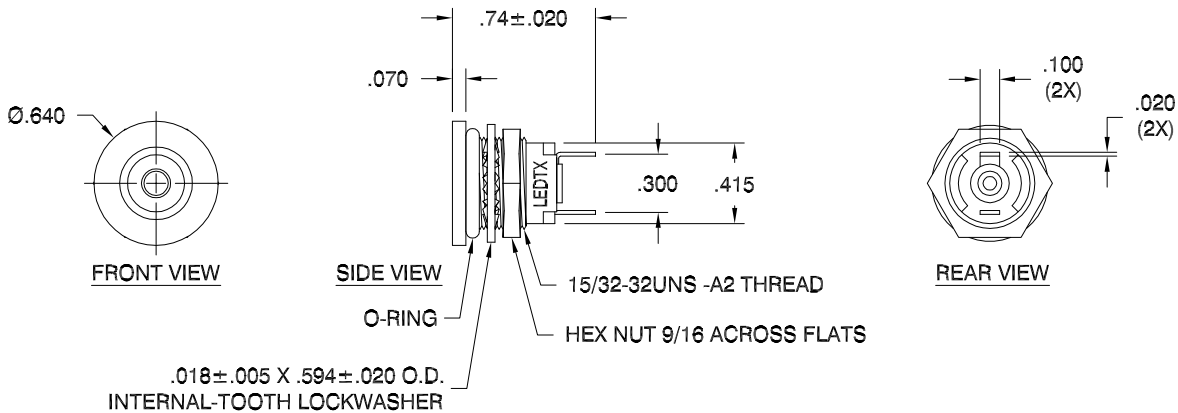
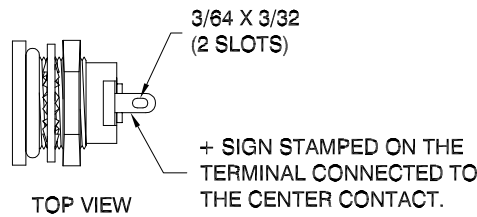

MATERIALS AND FINISHES:

- HOUSING: BLACK ANODIZED ALUMINUM
- HEX NUT: STEEL, ZINC PLATED
- INTERNAL-TOOTH LOCKWASHER: STEEL, ZINC PLATED
- TERMINALS: BRASS HOT TIN PLATED LUG TYPE
- O-RING MATERIAL: SILICONE RUBBER
PER: ZZ-R765 CL 2
GRADE 70

NOTES:

1. ALL DIMENSIONS ARE IN INCHES.
2. MOUNTING DIAMETER 15/32"
3. HOLDER ACCEPTS T1-3/4 MIDGET FLANGE BASE LED LAMP.
4. HOLDERS MEET MIL SPEC MIL-L-3661/47
5. MFS470B-WP IS MIL TYPE LH89/1
6. OPERATING VOLTAGE: 2.0-68VDC
7. OPERATING TEMPERATURE: -55C - +85C
8. TIGHTENING TORQUE: 0.5 FT-LBS

REVISION NOTIFICATION	
<input type="checkbox"/>	DLC
<input type="checkbox"/>	UL/ETL
<input type="checkbox"/>	MADE IN USA
<input type="checkbox"/>	CUSTOMER _____
<input type="checkbox"/>	OTHER _____
REDLINE CHECKLIST	
<input type="checkbox"/>	REDLINE(YES)
<input type="checkbox"/>	DATE: _____
<input type="checkbox"/>	INITIATED BY: _____
<input type="checkbox"/>	ECR REQUIRED YES <input type="checkbox"/> NO <input type="checkbox"/>
<input type="checkbox"/>	WORK ORDER# _____

LED[®]
LEDTRONICS,™ INC.
23105 KASHIWA COURT
TORRANCE, CA 90505

-PROPRIETARY-
This document contains Proprietary information of LEDTRONICS,™ INC. It may not be copied, used or disclosed for any purpose without the prior express written consent of LEDTRONICS,™ INC.

.XXX ± .010 TOLERANCE PER ANSI-Y14.5
.XX ± .025 (UNLESS OTHERWISE STATED)
ANGLES ± 0°,30'
FRACT. ± 1/32

TITLE HLDR-MFS470B-WP							
DWG NO CMHD0032-CUST		SCALE 1:1		SHEET 1 OF 1		DATE 10-10-08	
CODE IDENT NO. 8Z410	DWG BY GP 10-10-08	CHK BY	QA SB 05-10-19	MFG LD 05-10-19	R&D UF 05-10-19		