

Thermoelectric Assemblies



About Laird Thermal Systems

Laird Thermal Systems develops thermal management solutions for demanding applications across global medical, industrial, transportation and telecommunications markets. We manufacture one of the most diverse product portfolios in the industry ranging from active thermoelectric components and assemblies to temperature controllers and liquid cooling systems. Our engineers use advanced thermal modeling and management techniques to solve complex heat and temperature control problems. By offering a broad range of design, prototyping and in-house testing capabilities, we partner closely with our customers across the entire product development lifecycle to reduce risk and accelerate their time-to-market. Our global manufacturing and support resources help customers maximize productivity, uptime, performance and product quality. Laird Thermal Systems is the optimum choice for standard or custom thermal solutions.

Laird Thermal Systems partners with its customers to design custom thermal solutions for applications in many industries including:

- Medical Diagnostics
- Medical Imaging
- Battery Cooling
- Industrial Laser Systems
- Optoelectronics
- Analytical Instrumentation
- Semiconductor Fabrication
- Aerospace Defense
- Food & Beverage
- Automotive

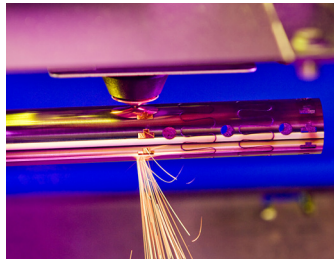

Introduction

Thermoelectric Assemblies (TEAs) are compact units that control the temperature of a wide variety of applications, such as laser diode packages in active optics, lasers in medical and industrial instrumentation, electronic enclosures, sample storage chambers in medical diagnostics and analytical instruments and batteries in various automotive and telecom applications. TEAs serve a cooling capacity spectrum from approximately 10 to 400 Watts, and can cool by removing heat from control sources through convection, conduction, or liquid means.

Advantages

TEAs offer several advantages over other cooling technologies. For example, conventional fan trays do not cool to below ambient and require an air exchange with the outside environment. On the other hand, TEAs can cool to well below ambient and protect electronics inside enclosures from outside contaminants, and also limit moisture exposure from the outside environment. TEAs also offer precise temperature control and accuracies to within 0.01°C are achievable under steady-state conditions.

TEAs have several advantages over conventional compressor-based systems:

- Compact size and lower weight than conventional compressor-based systems
- Mountable in any orientation and have lower noise and vibration
- Environmentally friendly, as TEAs do not use CFCs and are RoHS compliant
- Low to no field maintenance requirement, which lowers the total cost of ownership.

Engineers must now consider thermal management early in the product design process. Simple thermal management solutions, such as adding a fan or heat sink, are no longer typically viable to meet required performance and reliability specifications.

A standard TEA allows the designer to start with a basic set of building blocks that mate fans and TEMs to heat exchangers. Laird Thermal Systems has conducted two decades worth of design and validation testing on various combinations of thermal components to optimize cooling power and efficiency at various heat loads. This results in engineers saving time with redesign and validation testing a TEA that has already been perfected by Laird Thermal Systems.

Below is a summary of inherent benefits of initiating a thermal design with a standard TEA versus a custom solution:

1. Reduce product development time by initiated product at TEA level vs TEM level.
2. Reduce costs by utilizing components that are already established in the supply chain.
3. Long term history of products in field provide reliable field data of robustness of products in operation.
4. Product enhancements are captured through market evolution.

SuperCool Series

The SuperCool Series is designed for precise temperature control of small chambers used in medical diagnostics or sample storage compartments in analytical instrumentation. Featuring a high performance hot side air heat sink, the SuperCool TEA dissipates heat more quickly and efficiently than standard thermoelectric assemblies. These units operate on 24 VDC and are designed for indoor lab use environments. Custom configurations available upon request.

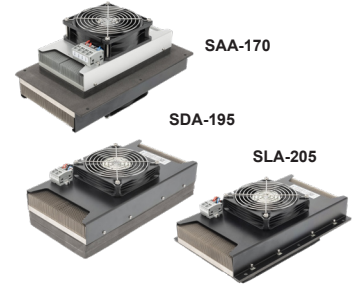
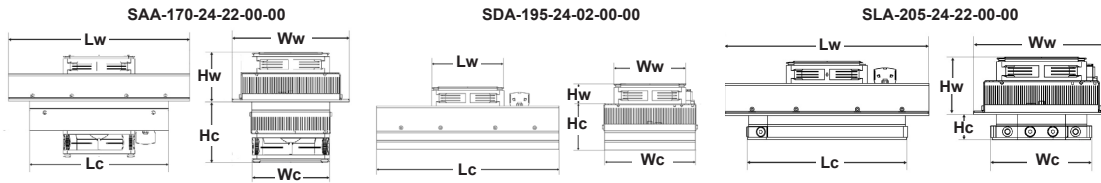

PART NO.	COOLING POWER (W)	NOMINAL VOLTAGE (V)	CURRENT (A)	WEIGHT (kg)	DIMENSIONS (mm)					
					Lw	Lc	Ww	Wc	Hw	Hc
SAA-170-24-22-00-00	166	24	6.9	4.5	300	230	180	119	70	93
SDA-195-24-02-00-00	193	24	6.9	4.1	119	300	119	153	25	72
SLA-205-24-22-00-00	202	24	6.9	4.1	300	236	180	120	74	33

PowerCool Series

The Power Cool Series offers the widest selection of cooling capacities ranging from 20 to 283 Watts. The TEAs use impingement flow to dissipate heat on the hot side. The cold side heat transfer mechanism can absorb heat using convection (heat sink and fan), conduction (cold plate), or liquid (heat exchanger) means. This product series is offered in 12 or 24 VDC configurations. For 100 Watt systems and higher, 48 VDC is available. The Power Cool Series is designed for indoor use in the medical, analytical, and industrial markets.

Air-to-Air Systems (AA)

Air-to-Air Assemblies offer dependable, compact performance by cooling objects via convection. Heat is absorbed and dissipated by heat exchangers equipped with fans and ducted shrouds. Specifications apply to ambient temperature of 32°C and nominal voltage with tolerances ±10%.

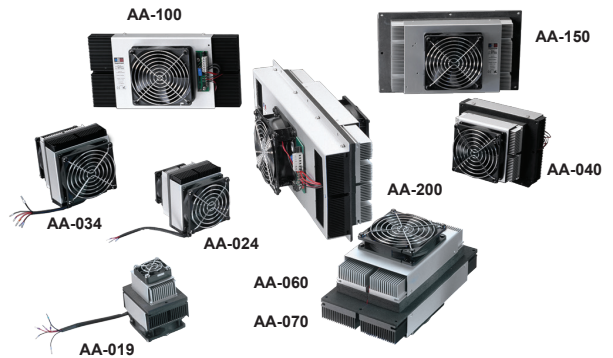
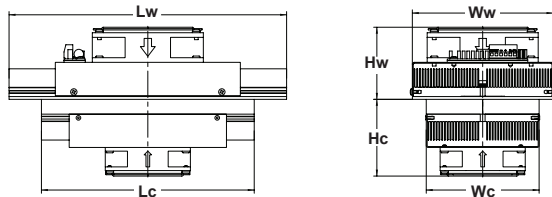

PART NO.	COOLING POWER (W)	NOMINAL VOLTAGE (V)	CURRENT (A)	WEIGHT (kg)	DIMENSIONS (mm)					
					Lw	Lc	Ww	Wc	Hw	Hc
AA-019-12-22-00-00	20	12	2.3	0.3	80	60	62	40	57	48
AA-024-12-22-00-00	24	12	2.4	0.6	100	80	82	62	60	62
AA-024-24-22-00-00	24	24	1.5	0.6	100	80	82	62	60	62
AA-034-12-22-00-00	33	12	3.5	0.9	120	100	102	82	60	64
AA-040-12-22-00-00	41	12	6.3	1.8	160	120	122	102	68	79
AA-040-24-22-00-00	39	24	2.6	1.8	160	120	122	102	68	78
AA-060-12-22-00-00	58	12	6.2	2.5	230	180	122	102	68	78
AA-060-24-22-00-00	58	24	3.1	2.5	230	180	122	102	68	78
AA-070-24-22-00-00	71	24	3.8	2.5	230	180	122	102	68	84
AA-100-24-22-00-00	102	24	5.6	4.0	300	230	152	122	75	86
AA-150-24-22-00-00	143	24	7.9	4.1	300	250	153	152	80	86
AA-200-24-22-00-00	195	24	11.3	7.0	400	350	153	152	85	93
AA-200-48-22-00-00	195	48	5.7	7.0	400	350	153	152	85	93

Direct-to-Air Systems (DA)

Direct-to-Air Assemblies offer dependable, compact performance by cooling objects via conduction. Heat is absorbed through a cold plate, pumping the heat through the TEM and dissipating it into the air through a heat sink equipped with fan and shroud. Specifications apply to an ambient temperature of 32°C and nominal voltage with tolerances ±10%.

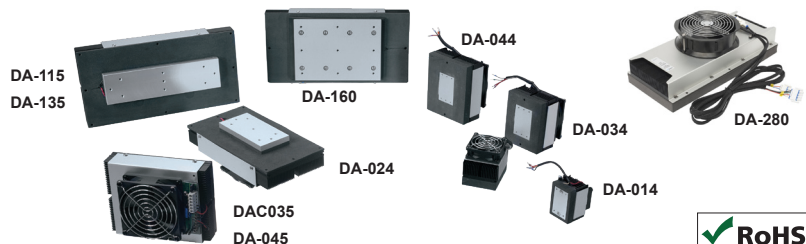
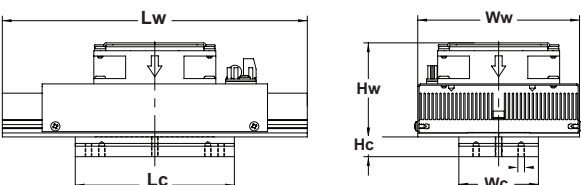

PART NO.	COOLING POWER (W)	NOMINAL VOLTAGE (V)	CURRENT (A)	WEIGHT (kg)	DIMENSIONS (mm)					
					Lw	Lc	Ww	Wc	Hw	Hc
DA-014-12-02-00-00	12	12	1.8	0.2	60	50	40	30	44	11
DA-024-12-02-00-00	24	12	2.4	0.3	80	60	60	40	56	14
DA-024-24-02-00-00	24	24	2.4	0.3	80	60	60	40	56	14
DA-034-12-02-00-00	34	12	2.6	0.5	100	60	80	40	59	14
DA-034-24-02-00-00	34	24	1.9	0.5	100	60	80	40	59	14
DA-044-12-02-00-00	42	12	3.8	0.6	120	60	100	40	60	14
DA-044-24-02-00-00	44	24	2.2	0.6	120	60	100	40	60	14
DA-045-12-02-00-00	48	12	6.1	1.2	160	60	122	60	71	15
DA-045-24-02-00-00	45	24	2.5	1.2	160	60	122	60	71	15
DA-075-12-02-00-00	71	12	7.2	1.7	230	120	122	60	71	15
DA-075-24-02-00-00	71	24	3.7	1.7	230	120	122	60	71	15
DA-115-24-02-00-00	113	24	5.8	2.9	300	220	152	60	78	16
DA-135-24-02-00-00	135	24	6.9	2.9	300	220	152	60	78	16
DA-160-24-02-00-00	160	24	7.4	3.5	300	180	152	130	84	16
DA-280-24-02-00-00	283	24	1.3	6.124	400	354	180	154	135	31
DA-280-48-02-00-00	281	48	0.7	6.194	400	354	180	154	135	31

Liquid Series

Liquid Series TEAs are used to cool or heat a coolant flowing through a liquid heat exchanger. The heat exchanger is designed for a recirculating system and needs to be accompanied by a pump. The heat is absorbed by the heat exchanger and custom designed thermoelectric modules pump heat to mating heat transfer mechanism on heat dissipation side. The heat dissipation side can be convection (Liquid to Air), conduction, (Direct to Liquid) or via liquid (Liquid to Liquid).

Liquid-to-Air (LA)

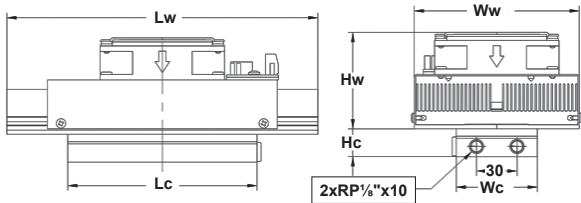

PART NO.	COOLING POWER (W)	NOMINAL VOLTAGE (V)	CURRENT (A)	WEIGHT (kg)	DIMENSIONS (mm)					
					Lw	Lc	Ww	Wc	Hw	Hc
LA-024-12-02-00-00	24	12	2.4	0.4	80	80	60	60	64	15
LA-024-24-02-00-00	24	24	2.0	0.4	80	80	60	60	64	15
LA-045-12-02-00-00	43	12	4.1	1.3	160	100	122	60	71	20
LA-045-24-02-00-00	47	24	2.8	1.3	160	100	122	60	71	20
LA-075-24-02-00-00	71	24	3.7	1.8	230	140	122	60	71	20
LA-115-24-02-00-00	113	24	5.8	3.0	300	240	152	60	78	20
LA-160-24-02-00-00	160	24	7.4	3.5	300	200	152	136	84	20

Direct-to Liquid (DL)

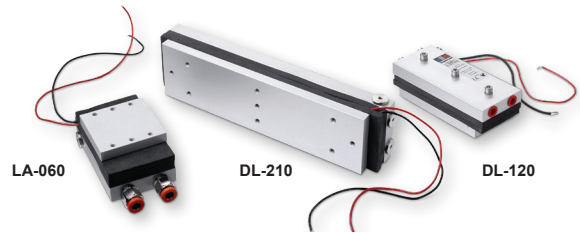
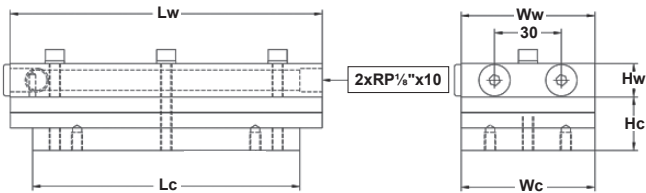

PART NO.	COOLING POWER (W)	NOMINAL VOLTAGE (V)	CURRENT (A)	WEIGHT (kg)	DIMENSIONS (mm)					
					Lw	Lc	Ww	Wc	Hw	Hc
DL-060-12-00-00	59	12	4.2	0.4	100	60	60	60	15	24
DL-060-24-00-00	59	24	2.1	0.4	100	60	60	60	15	24
DL-120-24-00-00	122	24	4.2	0.7	140	120	60	60	15	24
DL-210-24-00-00	207	24	8.1	1.3	240	120	60	60	15	24

Liquid-to-Liquid (LL)

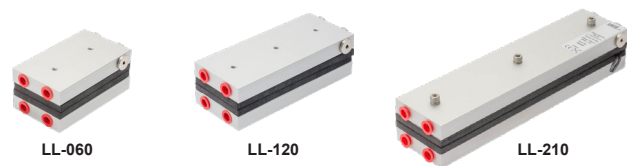
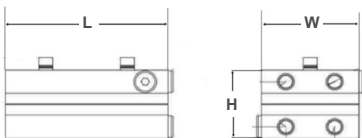

PART NO.	COOLING POWER (W)	NOMINAL VOLTAGE (V)	CURRENT (A)	WEIGHT (kg)	DIMENSIONS (mm)		
					Height	Length	Width
LL-060-12-00-00-00	66	12	3.9	0.5	44	100	60
LL-120-24-00-00-00	122	24	4.2	0.8	53	140	60
LL-210-24-00-00-00	208	24	7.9	1.4	53	240	60

Tunnel Series

The Tunnel Series TEAs are designed with a patented, high-performance cross flow technology that maximizes heat transfer when pulling air through a heat exchanger. The number of airflow paths required to operate is reduced when compared to traditional impingement flow TEAs. This product series is offered in 12 or 24 volt configurations and can cool by either convection or conduction means.

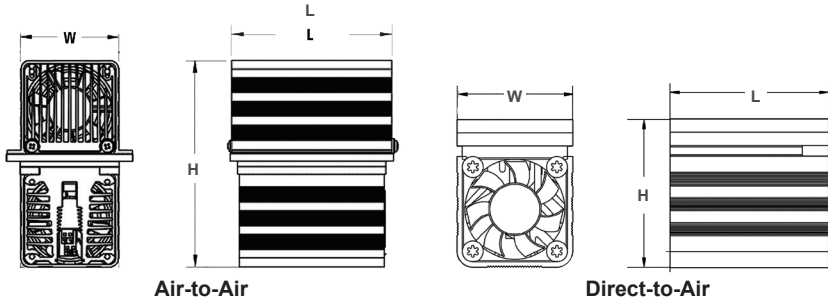

PART NO.	COOLING POWER (W)	NOMINAL VOLTAGE (V)	CURRENT (A)	DIMENSIONS (mm)		
				Height	Length	Width
DA-011-05-02-00-00	11	5	2.2	56	60	44
DA-033-12-02-00-00	32	12	3.1	82	99	66
ATT-027-12-22-00-00	27	12	2.3	142	115	84
AAT-032-12-22-00-00	33	12	2.8	141	155	84
AAT-055-12-22-00-00	56	12	5.3	142	180	84
ATT-055-24-22-00-00	55	24	2.6	142	180	84
AAT-085-12-22-00-00	82	12	8.1	154	248	83
AAT-085-24-22-00-00	85	24	4.2	154	248	83
DAT-029-12-02-00-00	29	12	2.6	87	96	65
DAT-040-12-02-00-00	40	12	2.7	85	155	65
DAT-065-12-02-00-00	65	12	5.1	85	180	65
DAT-065-24-02-00-00	64	24	2.6	85	180	65
DAT-105-12-02-00-00	103	12	8.5	98	248	83
DAT-105-24-02-00-00	106	24	4.4	98	248	83

Outdoor Cooler Series

The Outdoor Cooler Series is designed for outdoor use to control the temperature of electronic cabinets. The product series has been designed to pass harsh environmental demands such as earthquake resistance, salt fog, wind-driven rain, high temperature exposure and dust. The cooling capacity ranges from 100 to 250 Watts. This product series is offered in 24 and 48 VDC configurations and is designed for outdoor use in the telecom and industrial markets. As a standard option products are also sold with bi-polar thermostatic control to heat and cool to specific temperature set points.

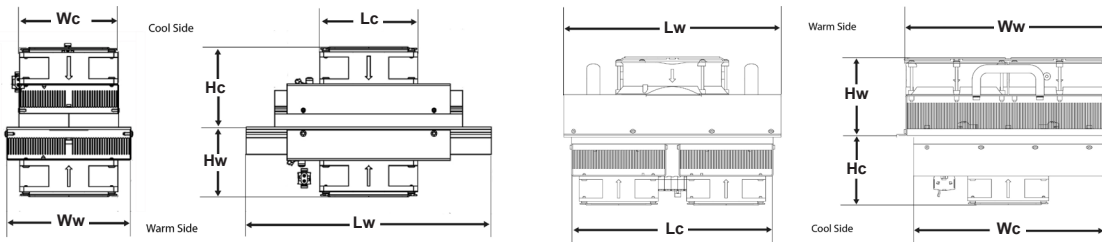

AA-100-, AA-150, AA-200, AA-250

AA-230, AA-480



PART NO.	COOLING POWER (W)	NOMINAL VOLTAGE (VDC)	CURRENT (A)	TEMPERATURE REGULATION	DIMENSIONS (mm)					
					Lw	Lc	Ww	Wc	Hw	Hc
AA-100-24-44-00-XX	102	24	5.6	Open Loop	300	200	152	122	81	99
AA-100-48-44-00-XX	102	48	2.8	Open Loop	300	200	152	122	81	99
AA-150-24-44-00-XX	143	24	7.9	Open Loop	300	250	153	152	80.4	98.5
AA-150-48-44-00-XX	143	48	3.9	Open Loop	300	250	153	152	80.4	98.5
AA-200-24-44-00-XX	193	24	11.3	Open Loop	400	350	153	152	85	98
AA-200-48-44-00-XX	193	48	5.6	Open Loop	400	350	153	152	85	98
AA-230-24-D44-00-XX	230	24	12.1		400	350	153	152	105	86
AA-230-48-D44-00-XX	230	48	6.1		400	350	153	152	105	86
AA-250-24-44-00-XX	244	24	12.1	Open Loop	350	400	153	152	99	105
AA-250-48-44-00-XX	244	48	6.1	Open Loop	350	400	153	152	99	105
AA-480-24-44-00-XX	480	24	19.3		171	330	303	280	122	103
AA-480-48-44-00-XX	480	48	6.1		171	330	303	280	122	103

Cascade Series

The Cascade Series is a TEA that is specifically designed to reach colder temperatures than standard TEA product offerings. The TEMs are custom designed multistage cascades that achieve a high cooling capacity (Q_c) at high temperature differentials (ΔT). The cold side mechanism can transfer heat using convective (sink and fan) or conductive (cold plate) means. This product series is offered in 12 or 24 volt configurations and is designed for indoor use in lab instruments.

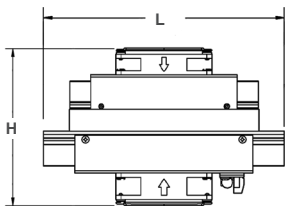
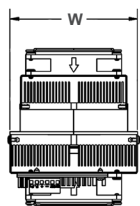

Air-to-Air

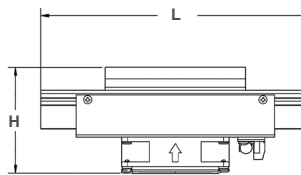
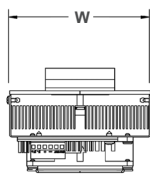

Direct-to-Air

PART NO.	COOLING POWER	NOMINAL VOLTAGE (V)	CURRENT (A)	DIMENSIONS (mm)		
				Height	Length	Width
AAC-050-24-22-00-00	49	24	4.7	152	230	122
DAC-035-12-02-00-00	31	12	4.8	91	160	122
DAC-060-24-02-00-00	58	24	4.6	91	230	122

Temperature Controllers

Laird Thermal Systems offers three types of controllers to drive TEAs. The Q Series is designed for single directional thermostatic control. The PR Series is designed for PID control and comes with GUI to make adjustments on the fly. Bi-polar thermostatic controllers are available, but sold with Outdoor Cooler Series units only.

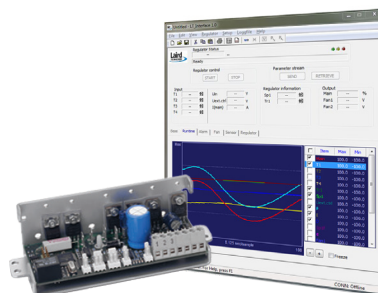

PART NO.	DESCRIPTION	REGULATION TYPE	TEMP RANGE (°C)	ACCURACY (°C)	INPUT VOLTAGE	MAX OUTPUT CURRENT	ALARM OUTPUTS
SR-54	Microcontroller based device	ON/OFF or PID	-20 to 100°C	±0.13°C	16 to 60 VDC	20 Amps, 28 VDC 12 Amps, 60 VDC	Yes
PR-59	Programmable PID Controller	PWM	Sensor Dependent	Sensor Dependent	11-30VDC	< 15A	Yes
QC-50	Single Directional Thermostatic	ON/OFF	Cool >5°C Off <2 °C	±1.0°C	11-58VDC	< 16A	Yes
QE-50	Single Directional Thermostatic	ON/OFF	Cool >35°C Off <32 °C	±1.0°C	11-58VDC	< 16A	Yes

MRC Series Recirculating Thermoelectric Chillers

MRC Chillers are self contained re-circulating chillers that offer dependable, compact performance by controlling the temperature of a coolant in a liquid circuit. The coolant is re-circulated using a pump with high mean time between failures (MTBF). Heat from the coolant is absorbed by a heat exchanger and dissipated through high density heat sinks equipped with brand name fans. The TEMs are custom designed to achieve long life operation. The unit is regulated with an easy-to-use digital temperature controller and is housed inside an aesthetic sheet metal casing.



MODEL	COOLING CAPACITY (dT=12°C)	FLOW RATE (@ 4 bar)	HEATING OPTION	WEIGHT (kg)	HEIGHT (in)	WIDTH (in)	DEPTH (in)
MRC 150-DH2-DVA	151 watts 515 Btu/hr	2.9 lpm	No	10.9	12.2	7.8	15.2
MRC 300-DH2-DVA	299 watts 1020 Btu/hr	3.3 lpm	No	13.6	15.4	8.4	13.3
MRC 150-DH2-HT-DVA	151 watts 515 Btu/hr	2.9 lpm	Yes	10.9	12.2	7.8	15.2
MRC 300-DH2-HT-DVA	299 watts 1020 Btu/hr	3.3 lpm	Yes	13.6	15.4	8.4	13.3

TEA Portfolio

Laird Thermal Systems offers the widest selection of TEAs on the market. Products are designed and manufactured to strict process control standards and pass/fail criteria, assuring that our customers receive the best possible TEAs. Our standard product portfolio includes an extensive array of thermal management solutions that cover a wide range of cooling capacities with compact form factors and high coefficient of performance. Standard operating voltages are 12 and 24 VDC, and on some models 48 VDC. The standard product offering includes heat transfer mechanisms designed to absorb and dissipate heat by convection, conduction, or through liquid heat exchangers. All products are manufactured in an ISO 9001:2008 certified facility and are designed to meet the cooling needs of many thermal management applications in the medical, analytical, industrial and telecom markets.

There are five distinct TEA product families that were designed for a specific cooling capacity range, temperature differential range or tight space constraint. The diagram to the right is a perceptual map of a cooling spectrum that can be used to guide designers to a particular product family that will have the desired attributes that the application requires.

Thermoelectric Applications

Thermoelectric Assemblies are used in a wide range of applications to stabilize the temperature of sensitive electronic components or to cool devices and compartments below ambient.

Telecommunications

Cooling below ambient is necessary to extend life of batteries in wireless base stations. Temperature stabilization is required to maintain peak performance of laser diodes.

- Telecom Enclosures
- Battery Backup Systems
- High Powered Laser Diodes

Medical

Temperature stabilization is required to obtain a high image resolution. Cooling reagent chambers below ambient is critical to extend life of reagents and keep replacement costs down. Rapid thermal cycling is crucial to speed up DNA amplification.

- Medical Imaging
- Clinical Diagnostics
- Medical Lasers
- Analytical Instrumentation
- PCR

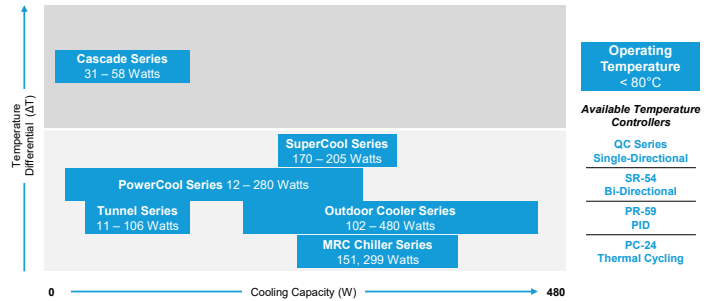

Industrial & Instrumentation

Temperature stabilization is critical to maintain industrial lasers at peak performance and allows high end printing systems to produce high quality prints at high run rates.

- High Powered Projectors
- Kiosks
- Metrology Instrumentation
- Digital Color Printing Systems
- Industrial Laser Systems

Food & Beverage

Temperature control is crucial to keep food fresh and beverages cold.

- Beverage Coolers
- Small Refrigerators
- Portable Food Containers
- Coffee Makers
- Juice Dispensers
- Vending Machines

Customization

Since there are so many unique attributes that need to be ascertained for each application, often a customized TEA will yield a more optimal thermal solution. Laird Thermal Systems offers strong engineering services with a global presence that supports onsite concept generation, thermal modeling, thermal design and rapid prototyping. We also offer validation test services to meet unique compliance standards for each industry, such as Telcordia, MIL-STDs or unique standards specific to a medical, automotive or industrial account. Minimum order quantity (MOQ) applies for all custom TEA designs and validation testing. Contact Laird Thermal Systems today to support your customization needs.

On Sight Concept Generation

Mechanical Design Support

Thermal Modeling Analysis

Temperature Control Design

Prototype Development

Validation Testing

Regional Manufacturing Capabilities

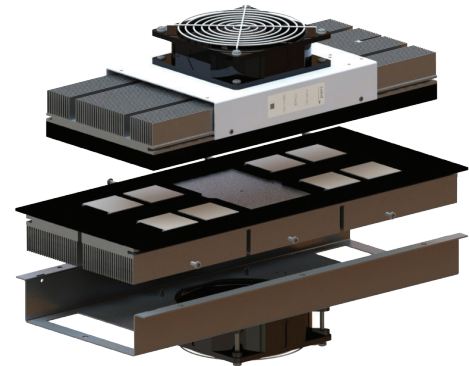

THERMAL SYSTEMS

Americas: +1.919.597.7300

Europe: +46.31.420530

Asia: +86.755.2714.1166

www.lairdthermal.com

THR-BRO-THERMOELECTRIC-ASSEMBLIES 121918

Any information furnished by Laird, Inc. and its agents is believed to be accurate and reliable. All specifications are subject to change without notice. Responsibility for the use and application of Laird materials rests with the end user, since Laird and its agents cannot be aware of all potential uses. Laird makes no warranties as to the fitness, merchantability or suitability of any Laird materials or products for any specific or general uses. Laird shall not be liable for incidental or consequential damages of any kind. All Laird products are sold pursuant to the Laird Terms and Conditions of sale in effect from time to time, a copy of which will be furnished upon request. © Copyright 2018 Laird, Inc. All Rights Reserved. Laird, the Laird Logo and other marks are trademarks or registered trademarks of Laird, Inc. or an affiliate company thereof. Other product or service names may be the property of third parties. Nothing herein provides a license under any Laird or any third party intellectual property rights.