

NOTES: UNLESS OTHERWISE SPECIFIED
 1. FOR USE WITH RG-58, 58A, 58C/U CABLE.

2. FOR CABLE INSTRUCTIONS SEE 3-7-1.

3. FOR CRIMPING USE DIE KTH-2001.

4. MATERIAL SPECIFICATIONS:
 INSULATOR: HIGH DENSITY POLYETHYLENE PER ASTM D4976
 GASKET: SILICONE RUBBER PER A-A-59588
 FERRULE: COMMERCIAL BRONZE PER ASTM B135
 BODY ASSY & WASHERS: BRASS PER ASTM B16
 HEAT SHRINK TUBING: POLYOLEFIN PER MIL-I23053/5 COLOR: WHITE
 ALL OTHER METAL PARTS: BERYLLIUM COPPER PER ASTM B196

5. FINISH SPECIFICATIONS:
 CENTER CONTACT: .000050 MIN GOLD PLATE PER ASTM B488 OVER
 .000050 MIN NICKEL PER AMS-QQ-N-290 (RoHS)
 FLAT & SPRING WASHER: .000200 MIN SILVER PER B700 OVER
 .000020 MIN COPPER PER ASTM B734 (RoHS)
 ALL OTHER METAL PARTS: 000050 MIN NICKEL PLATE PER AMS-QQ-N-290 OVER
 .000050 MIN COPPER PER ASTM B734 (RoHS)

6. ELECTRICAL SPECIFICATIONS:
 WORKING VOLTAGE: 10 KV DC

7. DIMENSIONS IN INCHS [MM]

REV	DESCRIPTION	BY DATE	APPD
01	ER052213	KPL 03/26/14	DCAM

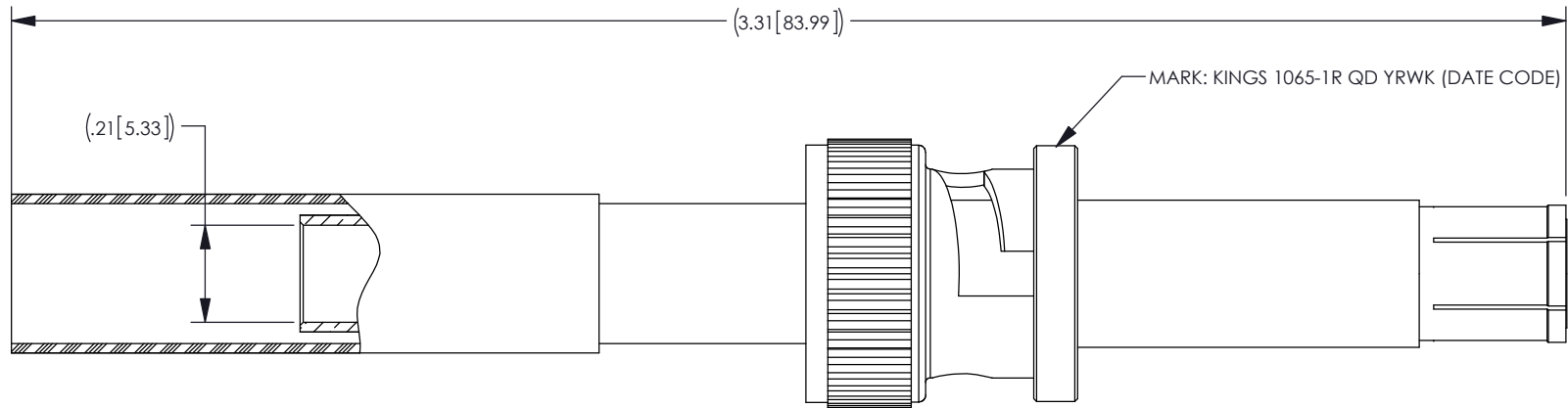
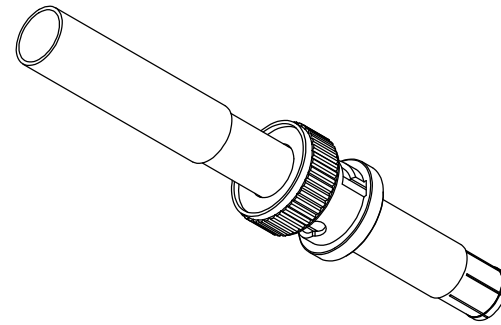

CATALOG P/N: 1065-1R QD

PER ASME Y14.5M-1994 UNLESS OTHERWISE SPECIFIED: DIMENSIONS ARE IN INCHES [MM] TOLERANCES: DECIMAL: .01 [X.X] ± .01 [0.3] .004 [X.XX] ± .005 [0.13] .XXXX [X.XXX] ± .XXXX ANGLES: ± 2° SCALE: 2.5:1				 by WINCHESTER Winchester Electronics Corporation 199 Park Road Ext Suite 104 ELECTRONICS Middlebury, Connecticut 06762							
CUSTOMER SALES DRAWING				THIRD ANGLE 		PLUG, 10KV (RoHS COMPLIANT)					
DRAWN	DATE	APPROVED	DATE	DRAWN	DATE	APPROVED	DATE	A	SD1065-1R QD	SHT OF 1 1	REV 01
KPL	03/26/2014	DCAM	03/26/2014	XXX	XX/XX/XX	XXX	XX/XX/XX				