

REVISIONS	
ISSUE	CHANGES
2	CN 27545 C SD 8 NOV 85

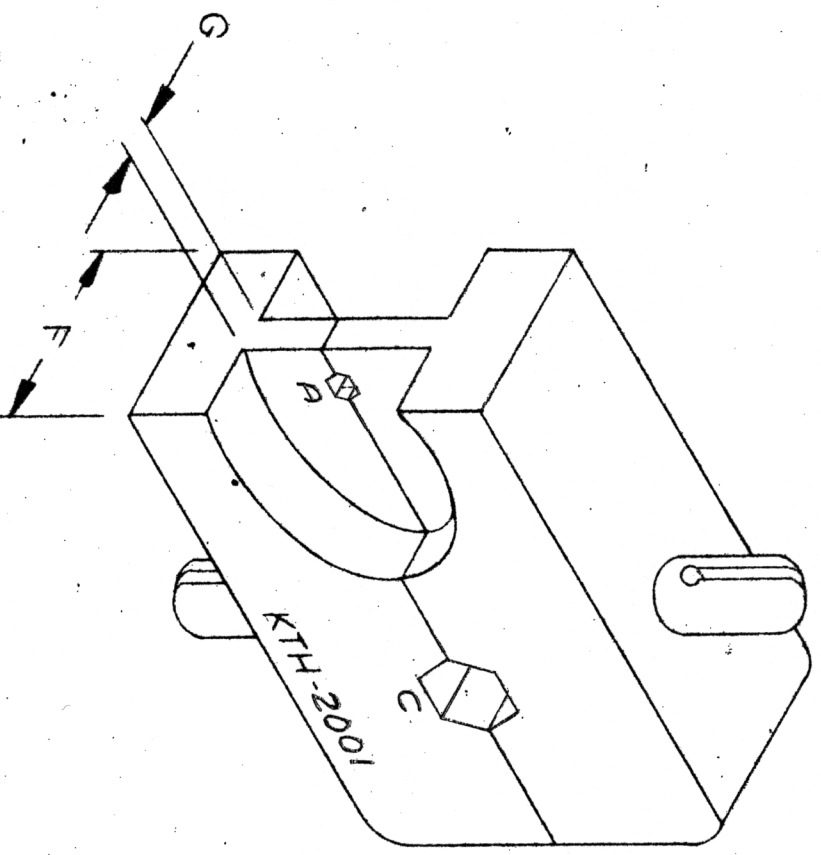

NOTES:
 1. FOR USE WITH RG-55, 58, 141, 142, 223 & 177
 BR/3077A CABLE GROUPS
 2. MATERIAL: ALLOY STEEL; FINISH: BLACK OXIDE

HEX SIZES (ACROSS FLATS)		DIE WIDTH		WEB WIDTH	
A	B	C	D	E	F
.069	—	.215	—	.400	.080

UNLESS OTHERWISE SPECIFIED:

1. TOLERANCES: FRACTIONS & 2 PLACE DECIMALS ± .010
2. REMOVE ALL BURRS, BREAK SHARP EDGES .005 MAX.
3. PLACE DECIMALS ± .004
3. NO FILLETS PERMITTED.
4. ANGLES ± 0° 30'
5. SURFACE ROUGHNESS 63 MICRONS RMS MAX.
1. 1 R. CONCENTRICITY OF ANY 2 DIAMETERS MAY NOT EXCEED HALF THE SUM OF THEIR TOLERANCES.
5. ALL DIMENSIONS PRIOR TO PLATING.

REF.	
FINISH	
SPEC	
MATL.	
SPEC	
CRIMP DIE	
DRAWN	JGL.
DATE	15 JUN 72
APPR.	

KINGS ELECTRONICS
 40 MARBLEDALE ROAD
 TUCKAHOE, N. Y. 10707

KTH-2001

2-CN