

S-D

KTH-2113

REVISIONS

| ISSUE | CHANGES |
|-------|----------------------------|
| 0 | ER 18743 L1 29 SEP 78 |
| 1 | CN 20938C GJG 13 AUG 80 |

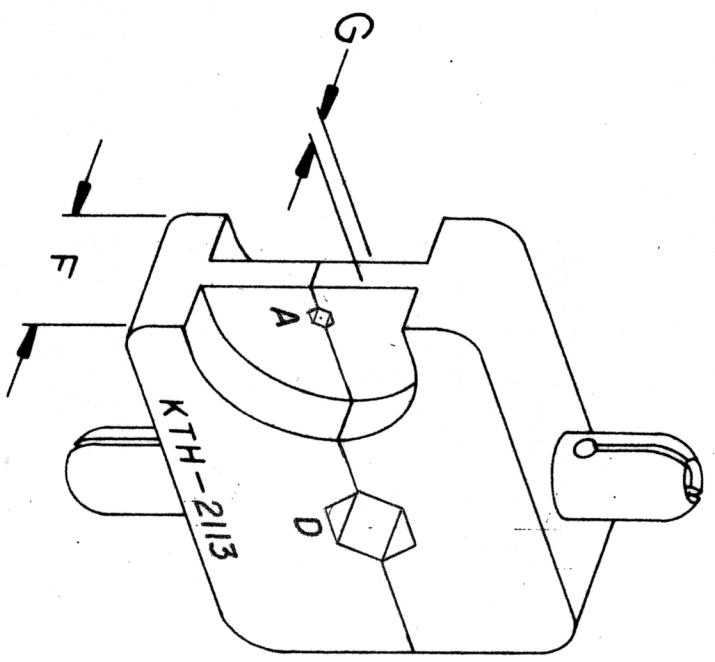

| HEX SIZES (ACROSS FLATS) | | DIE WIDTH | | DIE WIDTH | | | |
|--------------------------|---|-----------|------|-----------|------|---|---|
| A | B | C | D | F | G | H | I |
| .042 | | | .213 | .400 | .080 | | |

- UNLESS OTHERWISE SPECIFIED:
1. TOLERANCES: FRACTIONS & 2 PLACE DECIMALS ± .010
3 PLACE DECIMALS ± .004
ANGLES ± 0°30'
 2. REMOVE ALL BURRS, BREAK SHARP EDGES .005 MAX.
 3. NO FILETS PERMITTED.
 4. SURFACE ROUGHNESS 63 MICRONS RMS MAX.
 5. ALL DIMENSIONS PRIOR TO PLATING.
 6. ALL PLATING IN ACCORDANCE WITH KER 10004.
- T. I. R. CONCENTRICITY OF ANY 2 DIAMETERS MAY NOT EXCEED HALF THE SUM OF THEIR TOLERANCES.

S-D

SCALE: 2:1

USED ON:

REF:

CRIMP DIE

DRAWN: GL DATE: 24 FEB 83
APPR: MJB DATE: 24 FEB 83

SKINGS
ELECTRONICS CO., INC.
TUCKAHOE, NEW YORK 10707

S-D KTH-2113