

Three Phase Rectifier Bridge

$$I_{dAV} = 25 \text{ A}$$

$$V_{RRM} = 800-1800 \text{ V}$$

$V_{RSM/DSM}$ V	$V_{RRM/DRM}$ V	Type
900	800	VUO 22-08NO1
1300	1200	VUO 22-12NO1
1500	1400	VUO 22-14NO1
1700	1600	VUO 22-16NO1
1900	1800	VUO 22-18NO1

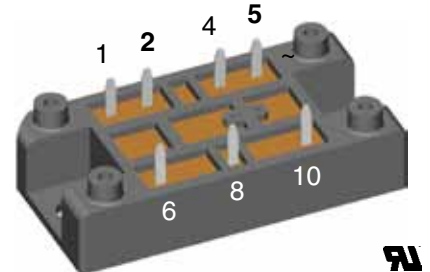
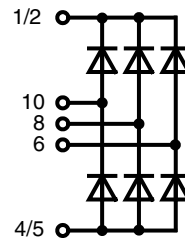

Symbol	Conditions	Maximum Ratings	
I_{dAV}	$T_C = 90^\circ\text{C}$, module	22	A
I_{dAV}	$T_A = 45^\circ\text{C}$ ($R_{thKA} = 0.5 \text{ K/W}$), module	25	A
I_{dAVM}	module	25	A
I_{FSM}	$T_{VJ} = 45^\circ\text{C}$; $t = 10 \text{ ms}$ (50 Hz)	100	A
	$V_R = 0$; $t = 8.3 \text{ ms}$ (60 Hz)	106	A
	$T_{VJ} = T_{VJM}$; $t = 10 \text{ ms}$ (50 Hz)	85	A
	$V_R = 0$; $t = 8.3 \text{ ms}$ (60 Hz)	90	A
I^2t	$T_{VJ} = 45^\circ\text{C}$; $t = 10 \text{ ms}$ (50 Hz)	50	A ² s
	$V_R = 0$; $t = 8.3 \text{ ms}$ (60 Hz)	47	A ² s
	$T_{VJ} = T_{VJM}$; $t = 10 \text{ ms}$ (50 Hz)	36	A ² s
	$V_R = 0$; $t = 8.3 \text{ ms}$ (60 Hz)	33	A ² s
T_{VJ}		-40...+130	°C
T_{VJM}		130	°C
T_{stg}		-40...+125	°C
V_{ISOL}	50/60 Hz, RMS $t = 1 \text{ min}$	3000	V~
	$I_{ISOL} \leq 1 \text{ mA}$ $t = 1 \text{ s}$	3600	V~
M_d	Mounting torque (M5) (10-32 UNF)	2 - 2.5	Nm
		18 - 22	lb.in.
Weight	Typ.	35	g

Features

- Package with DCB ceramic base plate
- Isolation voltage 3600 V~
- Planar passivated chips
- Blocking voltage up to 1800 V
- Low forward voltage drop
- UL registered E 72873

Applications

- Supplies for DC power equipment
- Input rectifiers for PWM inverter
- Battery DC power supplies
- Field supply for DC motors

Advantages

- Easy to mount with one screw
- Space and weight savings
- Improved temperature & power cycling

Symbol	Conditions	Characteristic Values	
I_R	$V_R = V_{RRM}$ $T_{VJ} = 25^\circ\text{C}$	0.3	mA
		5.0	mA
V_F	$I_F = 7 \text{ A}$ $T_{VJ} = 25^\circ\text{C}$	1.12	V
V_{T0}	For power-loss calculations only	0.8	V
r_t		40	mΩ
R_{thJH}	per diode, 120° rect.	3.1	K/W
	per module, 120° rect.	0.516	K/W
d_s	Creeping distance on surface	12.7	mm
d_A	Creepage distance in air	9.4	mm
a	Max. allowable acceleration	50	m/s ²

Data according to IEC 60747 and refer to a single diode unless otherwise stated.

IXYS reserves the right to change limits, test conditions and dimensions.

20100503a

© IXYS All rights reserved

1 - 3

Dimensions in mm (1 mm = 0.0394")

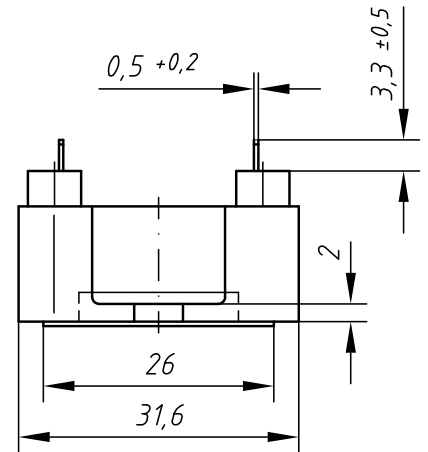
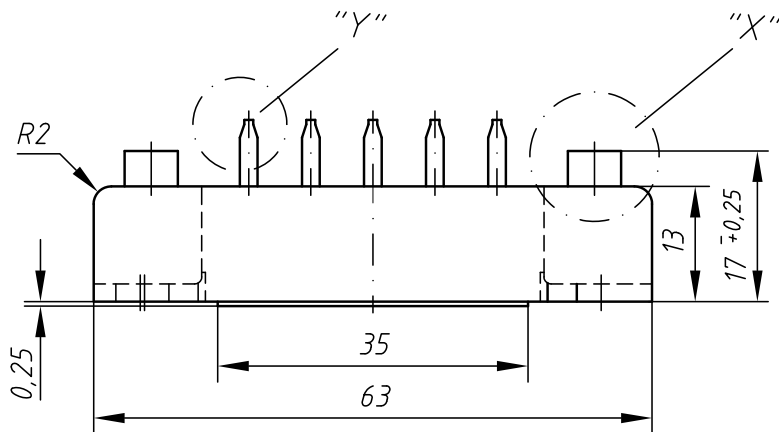

Detail "X" M 2:1

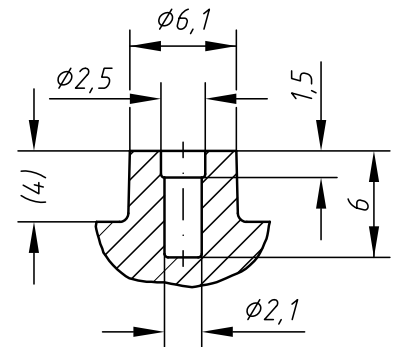
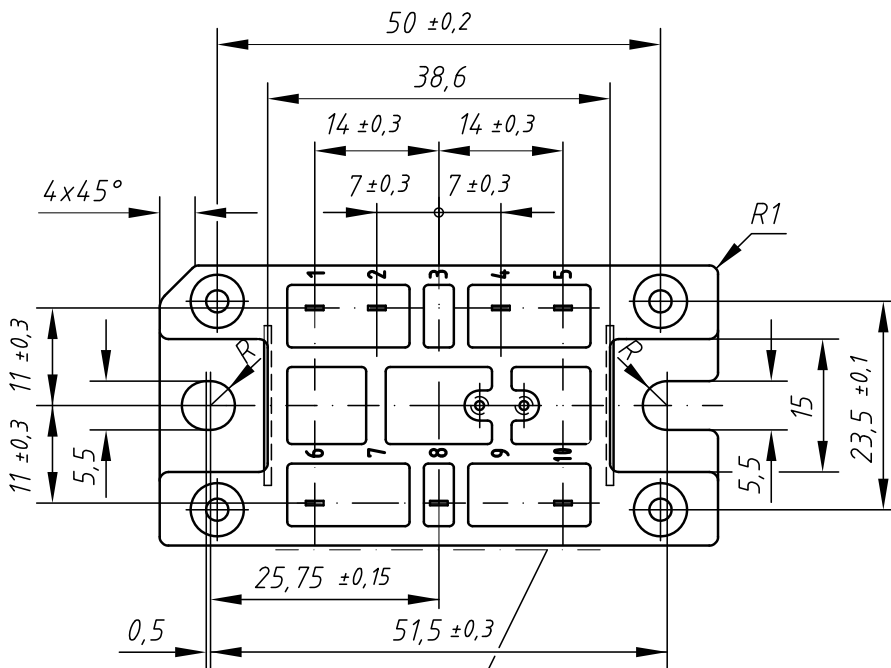

Detail "Y" M 5:1

Aufdruck der Typenbezeichnung
Marking on Product

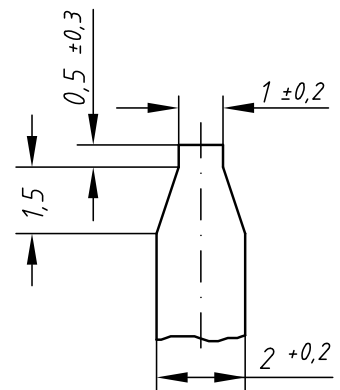

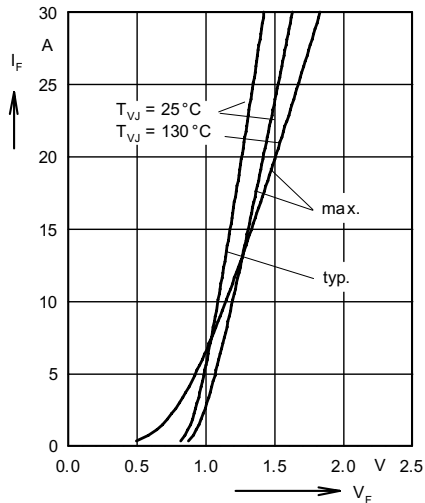

Fig. 1 Forward current versus voltage drop per diode

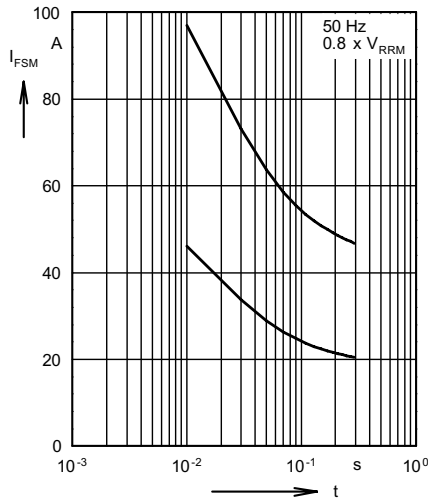

Fig. 2 Surge overload current per diode I_{FSM} : Crest value. t : duration

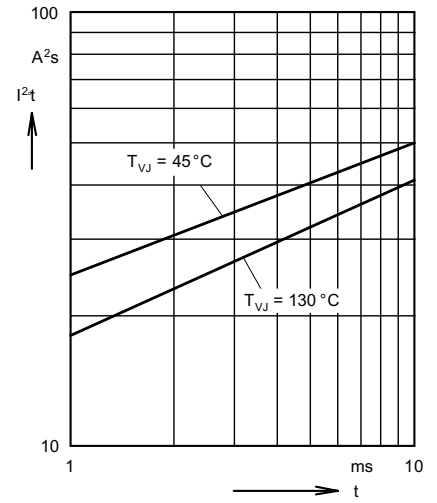

Fig. 3 I^2t versus time (1-10 ms) per diode

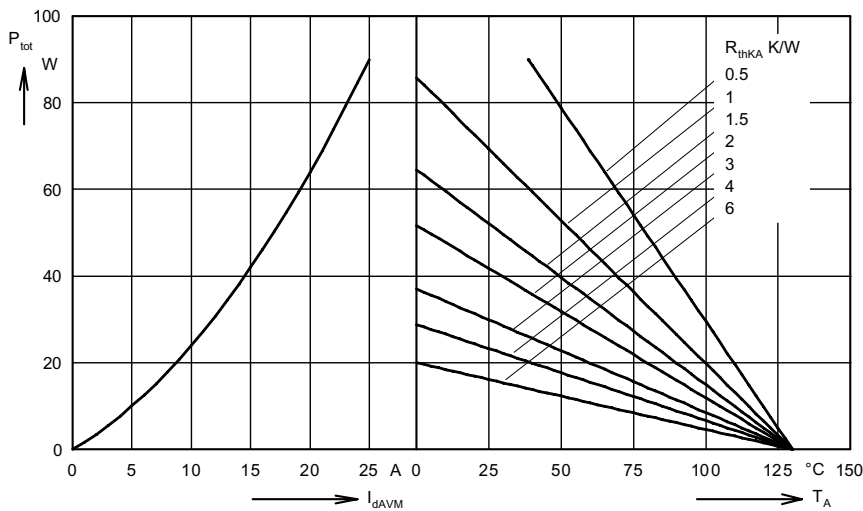

Fig. 4 Power dissipation versus direct output current and ambient temperature

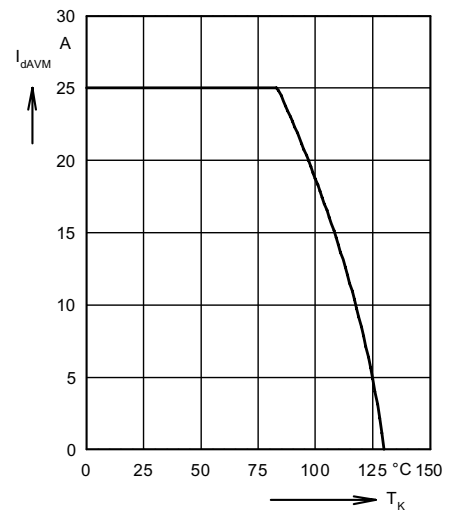

Fig. 5 Maximum forward current at case temperature

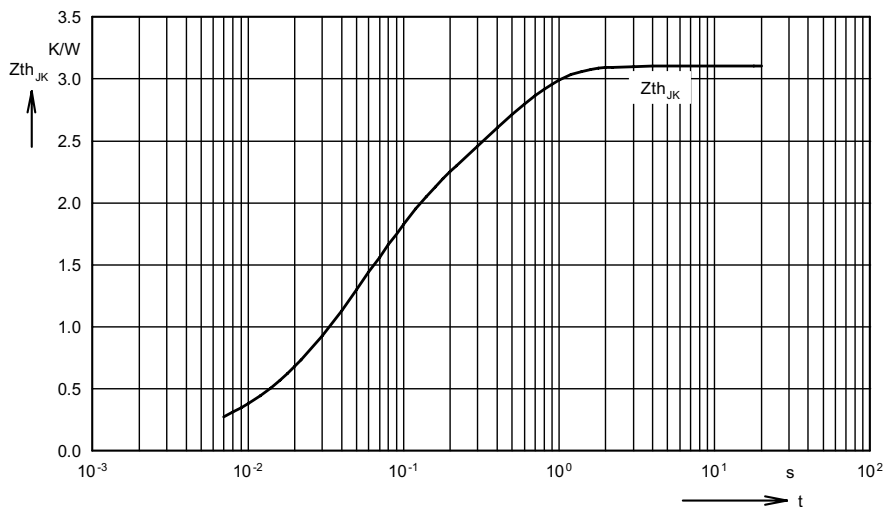

Fig. 6 Transient thermal impedance per diode

Constants for Z_{thJC} calculation:

i	R_{thi} (K/W)	t_i (s)
1	0.005	0.008
2	0.1	0.02
3	1.635	0.05
4	1.35	0.4