

**Type B—
Series 120**

**64 Contact Male Connectors
— Two Row**

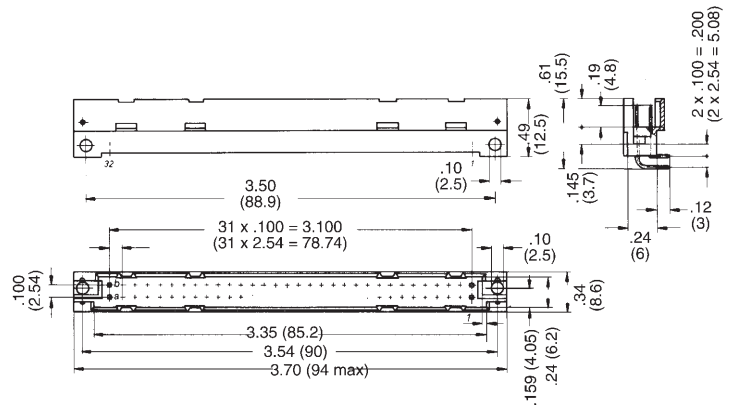

Printed Circuit Layout / Dip Solder Angled

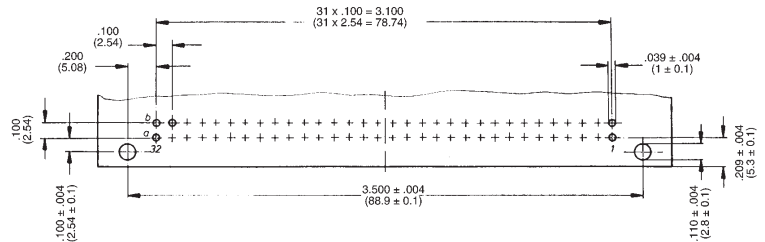

Printed Circuit Layout / Dip Solder Straight

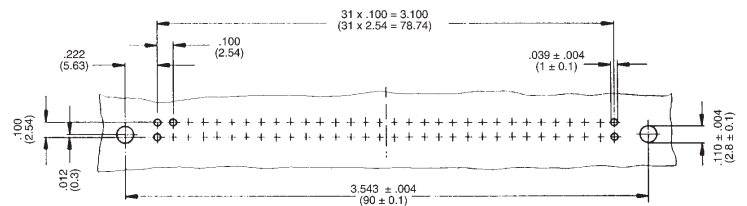

Part Numbers

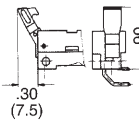
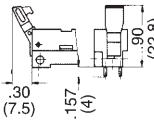
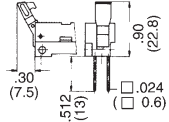
No. of Contacts	Performance Level	Style		
				
		Dip Solder Angled	Dip Solder Straight	Wire Wrap
64	2	120-064-033A	120-064-133A*	120-064-131A*
64	3	120-064-053A	120-064-153A	120-064-151A

* Contact Factory For Availability

Type B and Series 120

**64 Contact IDC Female Connectors—
Two Row**



Without Mounting Flange

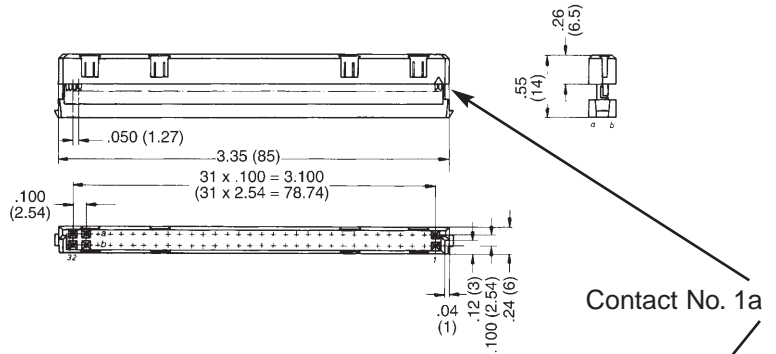

With Mounting Flange

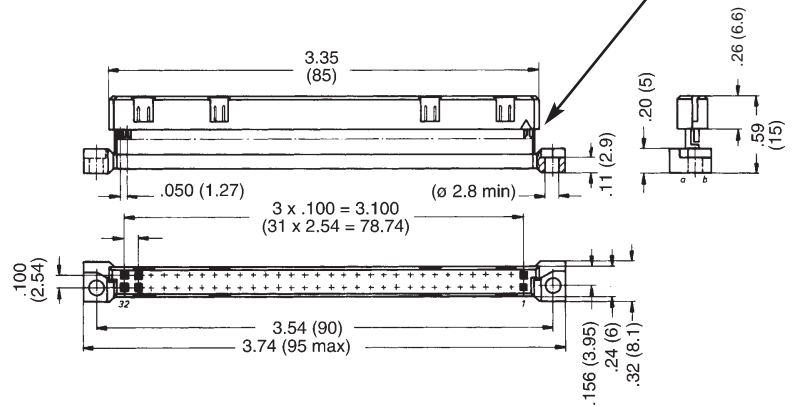

Part Numbers

No. of Contacts	Performance Level	Termination Methods	
		Through Connector	Through Connector with Mounting Flange
64	2	120-064-435	120-064-435F