

H and CH

TIME DELAY TIMERS

Industrial Timer Company
 30 Industrial Park Road
 Centerbrook, CT 06409
 800-394-7130
www.industrialtimercompany.com



DESCRIPTION

The H and CH series are standard time delay timers designed for panel mounting. The H timers cover the 15 and 30-second time ranges and have a clutch motor. The CH timers are available in 1, 3 and 5-minute time ranges and feature an external clutch to enable fast reset. It also features a motor control switch to protect the motor at the end of the time cycle. The CH is available in longer time ranges on special order. Both units provide automatic reset upon removal of power and have an isolated single pole, double throw load switch.

APPLICATION

These timers are designed for applications that require medium repeat accuracy and reset time and that may require the operator to change the time delay cycle. Typical applications include: furnace controls, welding equipment and a wide variety of other industrial machinery.

OPERATION

- 1) To set the duration of the time delay, set the selector knob to the desired time.
- 2) To start the time delay, close the customer-supplied switch connecting power to the motor and/or clutch.
- 3) At the end of the delay period the switch in the timer will change state.
- 4) After the timer has reached the timed out position, open the switch connecting power to the motor and/or clutch.
- 5) To start the time delay again, wait for the timer to reset and close the switch supplying power to the motor and/or clutch.

STANDARD MODELS

Model Number	Time Cycle	Dial Division
H-15S	15 Sec.	0.25 Sec.
H-30S	30 Sec.	0.50 Sec.
CH-1M	1 min	1 Sec.
CH-3M	3 min	3 Sec.
CH-5M	5 min	5 Sec.

Consult factory for longer time cycles

SPECIFICATIONS

Repeat Accuracy	Series H $\pm 1\%$ of full scale. Series CH $\pm 1.5\%$ of full scale.
Reset Time	Series H 5% of dial setting. Series CH 0.5 seconds at max setting.
Load Switch Contacts	Isolated SPDT switch, rated 20 amps 125, 250 or 480 VAC non-inductive.
Wiring	Screw type terminal block
Voltage	120V/60Hz standard. Consult factory for other voltages and frequencies.
Agency Approvals	UL, CSA

H and CH

TIME DELAY TIMERS

Industrial Timer Company
 30 Industrial Park Road
 Centerbrook, CT 06409
 800-394-7130
www.industrialtimercompany.com

DIMENSIONS

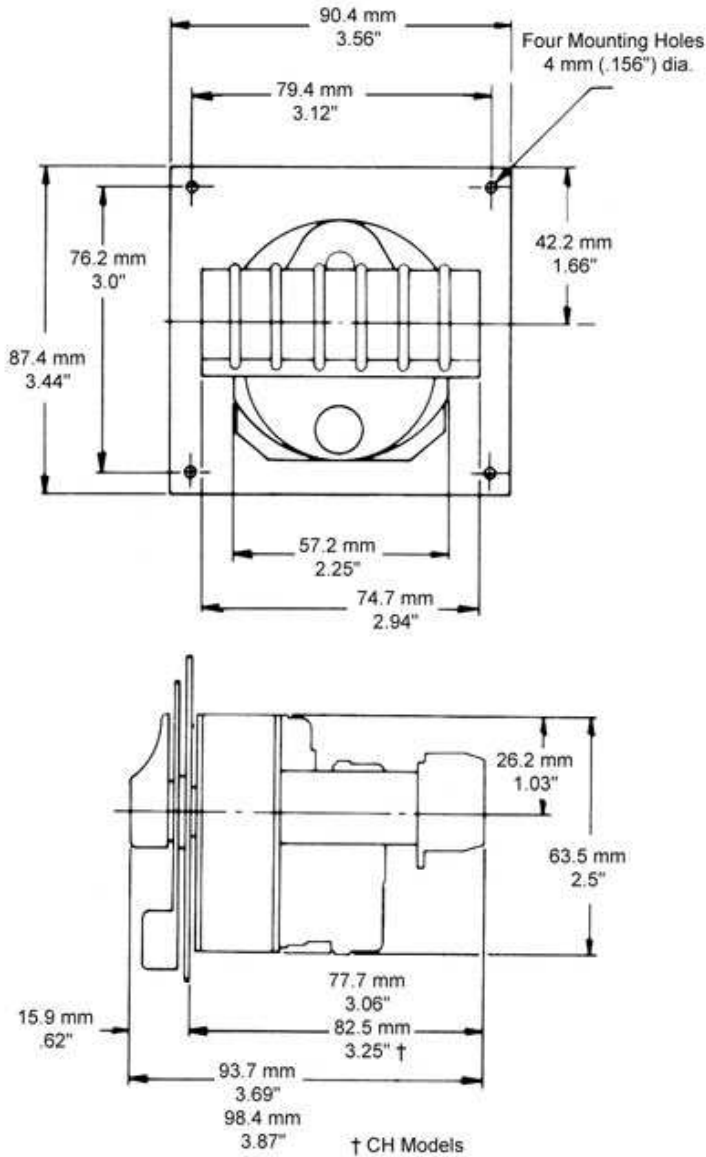

H WIRING

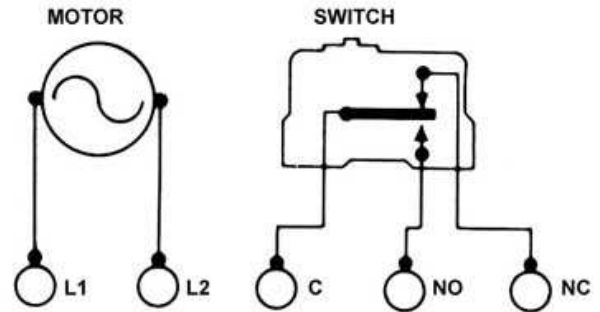

CH WIRING

