

Circuit Protectors

Selection Guide	1124
Internal Circuit Overview and Examples of Application	1126
[Hydraulic-magnetic Tripping]	
NH1S (Lever Type)	1127
NH1Y (Rocker Type)	1127
NH1L (Rocker Type with Indicator)	1127
NH1V (Lever Type)	1127
NRAS (Lever Type)	1139
NRAN (Lever Type)	1139
NRAR (Rocker Type)	1139
NRLT (Lever Type)	1151
NRLP (Lever Type with PC Board Terminal)	1151
NRLY (Rocker Type)	1151
NRLR (Rocker Type)	1151
NRLK (Large Rocker Type)	1151
NRBM (Lever Type)	1163
NRC Series (Sliding Knob Type)	1167
NRC□L (Lever Type)	1167
[Thermal Tripping]	
NRF Series	1173
NRPS/NRPF	1176

Flush
Silhouette

Control
Units

Display
Lights

Display
Units

Safety
Products

Terminal
Blocks

Comm
Terminals

AS-Interface

Relays &
Timers

Sockets

Circuit
Protectors

Power
Supplies

PLCs &
SmartRelay

Operator
Interfaces















Sensors

Control
Stations











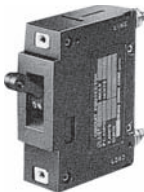



Explosion
Protection

References

Circuit Protector Selection Guide

Type		NH1S	NH1Y	NH1L	NH1V
Appearance					
		Lever Type	Rocker Type	Rocker Type •With indicator	Lever Type •DIN rail/Surface mounting
Tripping Method		Hydraulic-magnetic tripping			
No. of Poles		1 to 3 poles (Dual-coil type: 1-pole, 2-pole)	1, 2 poles	1, 2 poles	1 to 3 poles
Internal Circuit	Series Trip/Current Trip	Yes	Yes	Yes	Yes
	Relay Trip/Voltage Trip	Yes	Yes	Yes	Yes
	Dual-coil Type	Yes	—	—	—
Rating	Rated Voltage	250V AC 50/60 Hz, 65V DC			
	Rated Current (Current Trip)	Current trip: 0.5A to 30A Dual-coil type: 2A to 15A			
	Trip Voltage (Voltage Trip)	100V AC, 24V DC (Dual-coil type: 24V DC, 100V AC)			
	Rated Interrupting Capacity	250V AC/65V DC 1000A (UL/CSA rating), 220V AC 50/60Hz 1000A ()			
Time Delay Curves	2 types for DC, 3 types for AC				
Auxiliary Contacts/Alarm Contacts	With	With auxiliary contact	With auxiliary contact	With auxiliary contact	With
Inertia Delay	With	With	With	With	With
Mounting Style	Panel cut-out (Screw mounting)	Panel cut-out (Snap-on mounting)			DIN rail mounting, Surface mounting
Dimensions (H × W × D mm, 1-pole)	42 × 16 × 45	55 × 22 × 60			58.7 × 16 × 56
Certification	UL, c-UL, VDE,  	UL, c-UL, VDE,  	UL, c-UL, VDE,  	UL, c-UL, VDE,  	UL, c-UL, VDE,  
Page		1127	1127	1127	1127

Note: See the following pages for further information about the certified products.













Type		NRBM	NRLT	NRLP	NRLY	NRLY (Illuminated Type)
Appearance						
			Lever Type	Lever Type	Rocker Type	(LED/Neon) Illuminated Rocker Type
Tripping Method		Hydraulic-magnetic tripping				
No. of Poles		1 to 3 poles	1, 2 poles (1-lever)	1 pole	1, 2 poles (1-rocker)	1, 2 poles (1-rocker)
Internal Circuit	Series Trip/Current Trip	Yes	Yes	Yes	Yes	Yes
	Relay Trip/Voltage Trip	—	Yes	—	Yes	Yes
	Switch Type	—	Yes	—	Yes	Yes
Rating	Rated Voltage	250V AC, 50/60Hz, 65V DC	250V AC 50/60Hz, 50V DC			
	Rated Current (Current Trip)	1A to 50A	0.5A to 20A			
	Trip Voltage (Voltage Trip)	—	100V AC, 24V DC			
	Rated Interrupting Capacity	250V AC/65V DC 1000A	250V AC/750A (UL rating: 1000A), 50V DC/500A (UL rating: 1000A)			
Time Delay Curves	2 types for DC, 3 types for AC	3 types for DC 3 types for AC				
Auxiliary Contacts/Alarm Contacts	With	With auxiliary contact	With auxiliary contact	With auxiliary contact	With auxiliary contact	
Inertia Delay	With	With	With	With	With	
Mounting Style	Panel cut-out (Screw mounting)	Panel cut-out (Ring mounting)	PC board	Panel cut-out (Snap-on mounting)	Panel cut-out (Snap-on mounting)	
Dimensions (H × W × D mm, 1-pole)	63 × 19.1 × 63.5	36.6 × 16.8 × 42	36.6 × 16.8 × 46	50.8 × 22 × 46	50.8 × 22 × 46	
Certification	UL, c-UL, VDE,  	UL, CSA, VDE,  	UL, CSA, VDE, 	UL, CSA, VDE,  	UL, CSA, VDE,  	
Page		1163	1151	1151	1151	1151











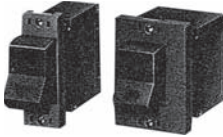

Note: See the following pages for further information about the certified products.

* Protectors indicated with  are for the switch type.

Also, the series trip and relay trip types of NRL series are excluded from .

Circuit Protector Selection Guide

NRAS	NRAN	NRAR	NRAR (Illuminated Type)
			
Lever Type	Lever Type	Rocker Type	(LED) (Neon Lamp) Illuminated Rocker Type
Hydraulic-magnetic tripping			
1 to 3 poles	1 to 3 poles	1 pole	1 pole
Yes	Yes	Yes	Yes
Yes	Yes	-	-
-	-	-	-
250V AC 50/60 Hz, 65V DC			
0.3A to 30A			
24V DC			
250V AC/65V DC, 1000A			
2 types for DC, 3 types for AC			
With	With	With	With
With	With	With	With
Panel cut-out (Screw mounting, snap-on mounting), Surface mounting (Plug-in base), DIN rail mounting (Width: 35 mm)			Panel cut-out (Screw mounting), Panel cut-out (Snap-on mounting)
50.7 × 19.1 × 54.5	50.7 × 19.1 × 50.5	52 × 19 × 65.5	52 × 19 × 65.5
UL, c-UL, VDE,  	UL, c-UL, VDE,  	UL, c-UL, VDE,  	UL, c-UL, VDE,  
1139	1139	1139	1139

NRLR	NRLR (Illuminated Type)	NRLK	NRC	NRC□L
				
Rocker Type	(LED/Neon) Illuminated Rocker Type	Large Rocker Type	Slide Type	Lever Type
Hydraulic-magnetic tripping			Hydraulic-magnetic tripping	
1, 2 poles (1-rocker)	1, 2 poles (1-rocker)	1, 2 poles (1-rocker)	1 pole	1, 2 poles
Yes	Yes	Yes	Yes	Yes
Yes	Yes	Yes	-	-
Yes	Yes	Yes	-	-
250V AC 50/60Hz, 50V DC			250V AC 50/60Hz, 65V DC	
Current trip: For 0.5A to 20A			For 0.3A to 30A	
100V AC, 24V DC			-	-
250V AC/750A (UL rating: 1000A), 50V DC/500A (UL rating: 1000A)			220V AC/2500A (2-pole: 1500A), 65V DC/1500A (2-pole: 750A)*	
3 types for DC, 3 types for AC			2 types for DC, 2 types for AC	
With auxiliary contact	With auxiliary contact	With auxiliary contact	With auxiliary contact	
With	With	With	-	
Panel cut-out (Screw mounting)	Panel cut-out (Screw mounting)	Panel cut-out (Screw mounting)	Surface mounting (Screw mounting) DIN rail mounting (Width: 35 mm) Panel cut-out (Bracket mounting)	
44 × 16.8 × 46	44 × 16.8 × 46	44 × 16.8 × 44	68 × 25 × 64 (Housing depth)	
UL, CSA, VDE,  	UL, CSA, VDE,  	UL, CSA, VDE,  	UL, CSA, 	
1151	1151	1151	1167	1167

Note: UL and CSA ratings may differ. See the following pages for details.

(Continued on the next page)

Flush Silhouette

Control Units

Display Lights

Display Units

Safety Products

Terminal Blocks

Comm. Terminals

AS-Interface

Relays & Timers

Sockets

Circuit Protectors

Power Supplies

PLCs & SmartRelay

Operator Interfaces







Sensors

Control Stations

Explosion Protection

References

Circuit Protector Selection Guide

Type	NRF1	NRF2	NRPS	NRPF
Appearance		With manual OFF mechanism 	Slim 	Flat 
Tripping method	Thermal tripping			
No. of Poles	1 pole		1 pole (SPST-NC, SPDT)	
Internal Circuit (Current Trip)	Series Trip		Series trip	
Rating	Maximum Circuit Voltage	32V DC, 250V AC		32V DC, 250V AC
	Rated Current	300, 500mA 1, 2, 3, 5, 8, 10, 15A		1, 1.6, 2, 3.15, 4, 5, 6A
	Rated Interrupting Capacity	300 mA to 5A: Rated current × 6 10, 15A: Rated current × 10		1A to 4A: Rated current × 10 (resistive load) 5A, 6A: 250V AC/40A, 32V DC/40A (resistive load)
	Tripping Time	No trip at the rated current Within 1 hour at 135% the rated current		No trip at the rated current Within 2 min at 175% the rated current
Reset Time	1 min minimum (*1)		1 min minimum (at 200% the rated current) (*1)	
Time Delay Curves	1 type		1 type	
Auxiliary Contacts	With		-	
Mounting Style	Panel cut-out (Snap-on mounting)		PC board mounting	
Certification	UL, CSA, TÜV (*2),  UL, 		UL, CSA	
Page	1173		1176	

*1: Reset time is the value at the reference ambient temperature of 25°C.

*2: TÜV certification: for 8A, 10A and 15A only.

Common Description of Circuit Protectors

Internal Circuit Overview and Application Examples

Series Trip

This is the most common circuit protector, providing excellent overload and short circuit protection. It can also be used as ON/OFF switch, except NRF and NRP series.

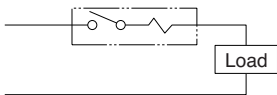

Series Trip with Auxiliary Contacts

As the auxiliary contact operation is interlocked with the ON/OFF of the main contactor, circuit protector operation can be monitored by a lamp. The auxiliary contact can also be used to control auxiliary circuits.

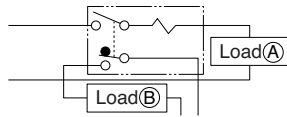

Series Trip with Alarm Contacts

The alarm contact is electrically independent of the ON/OFF of the main contactor, but actuates when the protective element operates. Therefore, the alarm contact can be used with a lamp or buzzer to indicate trip operation and control alarm circuits. After the alarm contact has tripped, turn the lever ON to set the alarm contact.

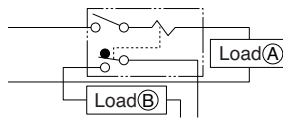

Dual-coil Type

The dual coil type circuit protector is provided with both a series trip (current trip) and relay trip (voltage trip). In the following example circuit, Coil A (current coil) performs overload and short circuit protection, while Coil B (voltage coil) serves to shut down the circuit when the alarm contact detects an abnormal condition.

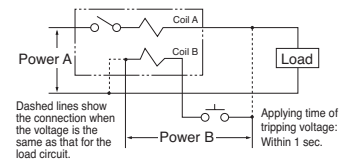

Relay Trip/Voltage Trip

The internal structure is identical to the current tripping protector, but the protective element has no time-delay function and the load circuit is cut off by the instantaneous tripping of the protector. Suitable for purposes, such as cutting off the power supply by using the alarm signal of the secondary circuit of the transformer.

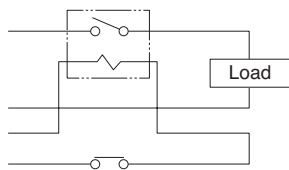

•Applications by Time Delay Curve

Time Delay Curves	Applications
Curve AD Curve AA	The most common curves used for circuit breakers.
Curve MD Curve MA	Suited for motor loads that draw high inrush currents lasting for a rather long period of time.
With inertia delay (Inertia delay mechanism)	Suited for transformer and lamp loads that draw steep inrush currents.

NH1 Series Circuit Protectors

Wide Range of Applications from Office Automation and Consumer Use to Factory Automation.

- Compact, lightweight, and high-performance circuit protectors.
- Rocker type snaps into a panel.
- Rated voltage: 250V AC and 65V DC
- 35mm-wide DIN rail mounting (NH1V)
- Available with dual-coil type
- Available with auxiliary contact or alarm contacts.
- Available with inertia delay
- Hydraulic-magnetic tripping system
- Safe trip-free mechanism
- Available in tab terminal type and screw-terminal type.

This product is recognized by Underwriters Laboratories under UL1077 as a "Supplementary Protector."

Applicable Standards	Certification Mark	Certification Organization / File No.
UL1077 CSA C22.2 No. 235 (Note 1)		UL/c-UL File No. E68029
EN60934 (VDE0642) (Note 2)		No. 107852
GB17701		CCC No. 2005010307152360
Electrical Appliance and Material Safety Law Technical Standard		JET

For details, see the list of standard certified products in the back of this catalog.

Note 1: Series trip, relay trip, dual coil (for AC)

Note 2: Series trip

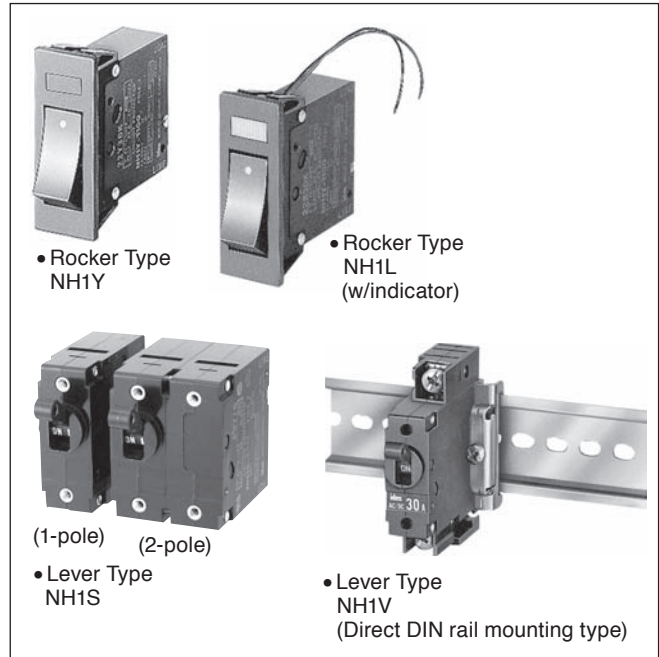

Specifications

Type	NH1S	NH1Y	NH1L	NH1V	Dual-coil Type
					NH1S
Operator Style	Lever	Rocker	Rocker (w/indicator)	Lever	Lever
Protection Method	Hydraulic-magnetic tripping system				Hydraulic-magnetic tripping system
Internal Circuit	Series trip (Current trip) Relay trip (Voltage trip)	Series trip with auxiliary contacts		Series trip with alarm contacts (NH1S and NH1V only)	Series trip (Current trip) + Relay trip (Voltage trip)
No. of Poles	1, 2, 3 poles	1, 2 poles	1, 2 poles	1, 2, 3 poles	1, 2 poles
Rated Voltage	250V AC 50/60Hz, 65V DC				250V AC 50/60Hz, 65V DC
Minimum Applicable Load	24V AC/DC, 100mA (reference value)				
Rated Current	Current trip: 0.5A, 0.75A, 1A, 2A, 3A, 5A, 7.5A, 10A, 15A, 20A, 25A, 30A				Current trip: 2A, 3A, 5A, 7.5A, 10A, 15A
Trip Voltage	100V AC 50/60Hz, 24V DC (operating at 90% of the rated voltage or higher, at 25°C) Voltage application duration: 1 sec maximum Trip time: 0.05 sec maximum (at the rated voltage)				External trip coil voltage: 24V DC, 100V AC (operating at 90% of the rated voltage or higher, at 25°C) Voltage application duration: 1 sec max. Trip time: 0.05 sec max. (at the rated voltage)
Rated Interrupting Capacity	250V AC 50/60Hz 1000A, 65V DC 1000A (UL/C-UL ratings) 220V AC 50/60Hz 1000A (
Auxiliary Contact Alarm Contact	SPDT microswitch 250V AC, 3A (resistive load)				-
Reference Temperature	+25°C				
Operating Temperature	-40 to +85°C (no freezing)				
Operating Humidity	45 to 85% RH (no condensation)				
Insulation Resistance	100 MΩ minimum (500V DC megger)				
Dielectric Strength	Between operator and live part, between terminals when main contacts are open, between live parts of different poles, and between main terminal and auxiliary contact terminal: 3750V AC, 1 min (NH1V: 1500V AC, 1 min) 600V AC, 1 min				Between operator and live part, between terminals when main contacts are open, between live parts of different poles, between voltage trip terminal and main terminal: 1500V AC, 1 min.
Vibration Resistance	100 m/s ² (10 to 100Hz) with the rated current applied				
Shock Resistance	Damage limits: 1000 m/s ² , Operating extremes: 500 m/s ² with the rated current applied. (Auxiliary/alarm contact: 300 m/s ²)				
Life	10,000 cycles min. (Electrically 6,000 cycles: 6 operations per minute at the rated current, mechanically 4,000 cycles: 6 operations per minute)				
Terminal Style	Main terminal: Tab terminal #250, M4 screw terminal Auxiliary terminal: Tab terminal #110		Main terminal: M4 screw terminal (20A max.) M5 screw terminal (25, 30A) Auxiliary terminal: M3.5 screw terminal		Main terminal: Tab terminal #250 Auxiliary terminal: Tab terminal #187
Mounting Style	Screw mounting	Snap mounting	Screw mounting, DIN rail mounting		Screw mounting
Weight (Approx.)	1-pole type: 45g 2-pole type: 90g 3-pole type: 135g	1-pole type: 50g 2-pole type: 100g	1-pole type: 65g 2-pole type: 130g 3-pole type: 195g		1-pole type: 45g 2-pole type: 90g

Flush
Silhouette

Control
Units

Display
Lights

Display
Units

Safety
Products

Terminal
Blocks

Comm.
Terminals

AS-Interface

Relays &
Timers

Sockets

Circuit
Protectors

Power
Supplies

PLCs &
SmartRelay

Operator
Interfaces

Sensors





Control
Stations

Explosion
Protection

References

NH1 Series Circuit Protectors

•Rocker Color, Rocker Indication (NH1Y/NH1L)

Rocker Color (Code)	Black (blank) Red (R), Green (G), White (W)
Rocker Indication (Code)	 (blank)  (A)  (C)  (D)

•Operating Voltage of Indicator (NH1L)

Indicator	Rated Voltage	Code	
Neon (Red)	125V AC, 50/60Hz (operating voltage: 100 to 125V AC)	1	
LED (Red) [Note]	For AC/DC (operating voltage: within +10% of the rated voltage)	6V	3
		12V	4
		24V	5
		48V	6

Note: Both types of indicators contain a current-limiting resistor.

•Operation of Auxiliary Contacts

Since auxiliary contact operations are interlocked with ON/OFF positions of main terminal, operating status of the circuit protector can be monitored using a lamp. Auxiliary contacts also serve as a control of auxiliary circuits.

Operator Position	NO Contact	NC Contact
ON	Closed	Open
Tripped	Open	Closed
OFF	Open	Closed

•Lever Color (NH1S, NH1V): Black

•Operation of Alarm Contacts

Alarm contacts are not interlocked with main contacts and operate only when an overcurrent occurs.

Operator Position	NO Contact	NC Contact
ON	Open	Closed
Tripped	Closed	Open
OFF	Open	Closed

[Type No. Example]

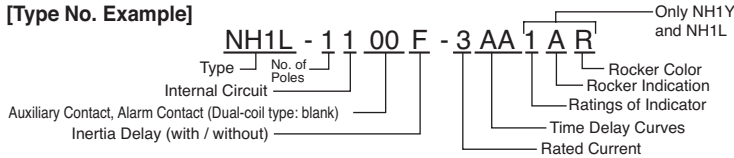

Type No. Development

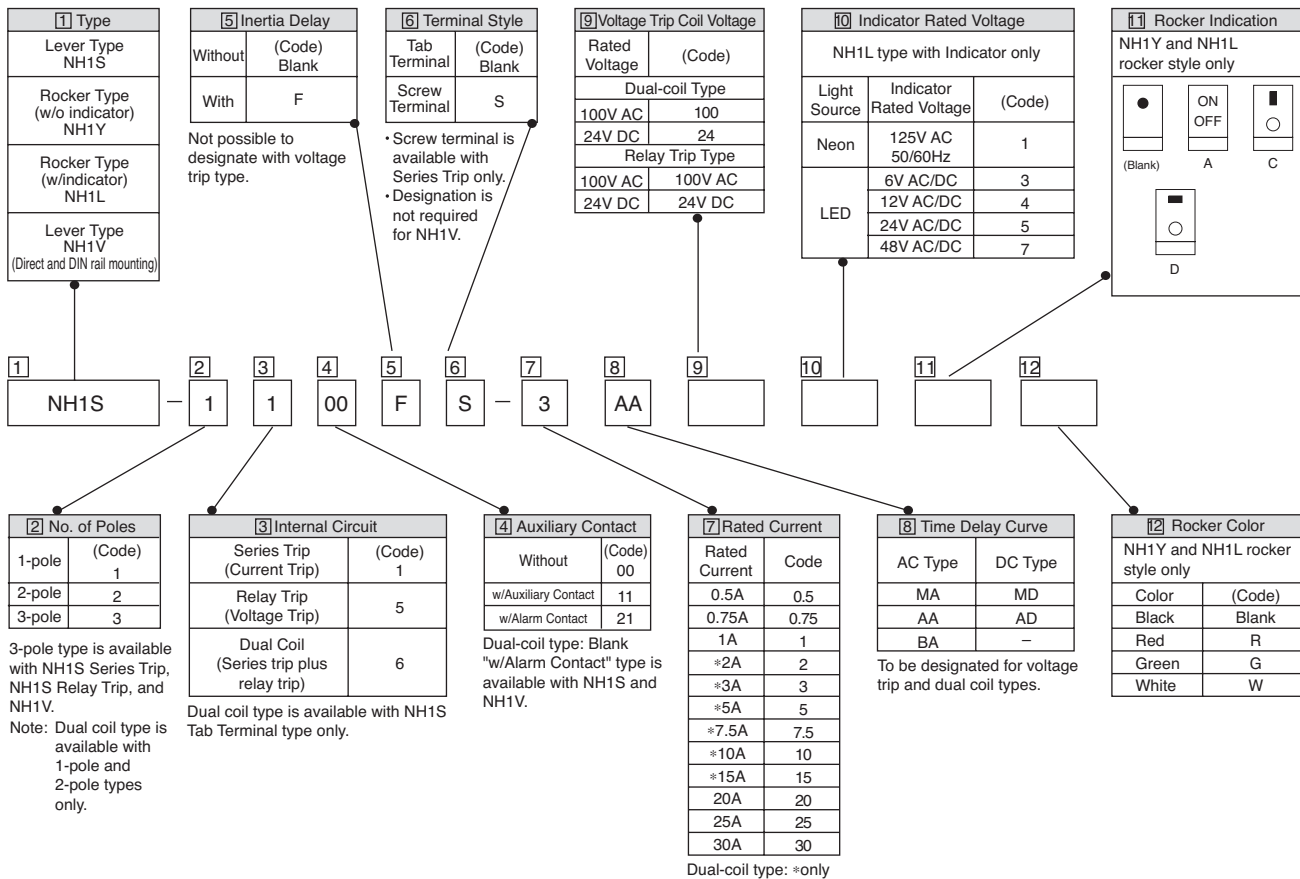

NH1S (Lever Type) Type No.

• Specify a rated current, time delay curve, and rated voltage in place of [7] [8] [9]. Package Quantity: 1

Internal Circuit	No. of Poles	Terminal Style	Inertia Delay	Auxiliary Contact Alarm Contact	Type No. (Ordering Type No.)	Designation Code		
						[7] Rated Current	[8] Time Delay Curve	[9] Rated Voltage
Series Trip Current Trip	1	Tab Terminal	Without	Without	NH1S-1100- [7] [8]	0.5A 0.75A 1A 2A 3A 5A 7.5A 10A 15A 20A 25A 30A	AA BA MA AD MD	-
				w/Auxiliary Contact	NH1S-1111- [7] [8]			
				w/Alarm Contact	NH1S-1121- [7] [8]			
		With	Without	NH1S-1100F- [7] [8]				
			w/Auxiliary Contact	NH1S-1111F- [7] [8]				
			w/Alarm Contact	NH1S-1121F- [7] [8]				
	Screw Terminal	Without	Without	NH1S-1100S- [7] [8]				
			w/Auxiliary Contact	NH1S-1111S- [7] [8]				
			w/Alarm Contact	NH1S-1121S- [7] [8]				
		With	Without	NH1S-1100FS- [7] [8]				
			w/Auxiliary Contact	NH1S-1111FS- [7] [8]				
			w/Alarm Contact	NH1S-1121FS- [7] [8]				
Series Trip Current Trip	2	Tab Terminal	Without	Without	NH1S-2100- [7] [8]	0.5A 0.75A 1A 2A 3A 5A 7.5A 10A 15A 20A 25A 30A	AA BA MA AD MD	-
				w/Auxiliary Contact	NH1S-2111- [7] [8]			
				w/Alarm Contact	NH1S-2121- [7] [8]			
		With	Without	NH1S-2100F- [7] [8]				
			w/Auxiliary Contact	NH1S-2111F- [7] [8]				
			w/Alarm Contact	NH1S-2121F- [7] [8]				
	Screw Terminal	Without	Without	NH1S-2100S- [7] [8]				
			w/Auxiliary Contact	NH1S-2111S- [7] [8]				
			w/Alarm Contact	NH1S-2121S- [7] [8]				
		With	Without	NH1S-2100FS- [7] [8]				
			w/Auxiliary Contact	NH1S-2111FS- [7] [8]				
			w/Alarm Contact	NH1S-2121FS- [7] [8]				
Series Trip Current Trip	3	Tab Terminal	Without	Without	NH1S-3100- [7] [8]	0.5A 0.75A 1A 2A 3A 5A 7.5A 10A 15A 20A 25A 30A	AA BA MA AD MD	-
				w/Auxiliary Contact	NH1S-3111- [7] [8]			
				w/Alarm Contact	NH1S-3121- [7] [8]			
		With	Without	NH1S-3100F- [7] [8]				
			w/Auxiliary Contact	NH1S-3111F- [7] [8]				
			w/Alarm Contact	NH1S-3121F- [7] [8]				
	Screw Terminal	Without	Without	NH1S-3100S- [7] [8]				
			w/Auxiliary Contact	NH1S-3111S- [7] [8]				
			w/Alarm Contact	NH1S-3121S- [7] [8]				
		With	Without	NH1S-3100FS- [7] [8]				
			w/Auxiliary Contact	NH1S-3111FS- [7] [8]				
			w/Alarm Contact	NH1S-3121FS- [7] [8]				
Relay Trip Voltage Trip	1	Tab Terminal	Without	Without	NH1S-1500- [9]	-	-	100V AC 24V DC
	2			Without	NH1S-2500- [9]			
	3			Without	NH1S-3500- [9]			
Dual-coil Type	1	Tab Terminal	Without	Without	NH1S-16- [7] [8] [9]	2A 3A 5A 7.5A 10A 15A	AA BA MA AD MD	100V AC 24V DC
			With	Without	NH1S-16F- [7] [8] [9]			
	2	Tab Terminal	Without	Without	NH1S-26- [7] [8] [9]			
			With	Without	NH1S-26F- [7] [8] [9]			

- Flush Silhouette
- Control Units
- Display Lights
- Display Units
- Safety Products
- Terminal Blocks
- Comm. Terminals
- AS-Interface
- Relays & Timers
- Sockets
- Circuit Protectors
- Power Supplies
- PLCs & SmartRelay
- Operator Interfaces
- Sensors
- Control Stations
- Explosion Protection
- References

NH1 Series Circuit Protectors

NH1Y (Rocker Type) Type No.

• Specify a rated current, time delay curve, rated voltage, rocker indication, and rocker color in place of **7 8 9 11 12**.

Package Quantity: 1

Internal Circuit	No. of Poles	Terminal Style	Inertia Delay	Auxiliary Contact Alarm Contact	Type No. (Ordering Type No.)	Designation Code				
						7 Rated Current	8 Time Delay Curve	9 Rated Voltage	11 Rocker Indication	12 Rocker Color
Series Trip Current Trip	1	Tab Terminal	Without	Without	NH1Y-1100- 7 8 11 12	0.5A 0.75A 1A 2A 3A 5A 7.5A 10A 15A 20A 25A 30A	AA BA MA AD MD	-	Blank, A, C, D	Blank, R, G, W
				w/Auxiliary Contact	NH1Y-1111- 7 8 11 12					
				w/Alarm Contact	-					
		With	Without	NH1Y-1100F- 7 8 11 12						
			w/Auxiliary Contact	NH1Y-1111F- 7 8 11 12						
			w/Alarm Contact	-						
	Screw Terminal	Without	Without	NH1Y-1100S- 7 8 11 12						
			w/Auxiliary Contact	NH1Y-1111S- 7 8 11 12						
			w/Alarm Contact	-						
		With	Without	NH1Y-1100FS- 7 8 11 12						
			w/Auxiliary Contact	NH1Y-1111FS- 7 8 11 12						
			w/Alarm Contact	-						
Series Trip Current Trip	2	Tab Terminal	Without	Without	NH1Y-2100- 7 8 11 12	0.5A 0.75A 1A 2A 3A 5A 7.5A 10A 15A 20A 25A 30A	AA BA MA AD MD	-	Blank, A, C, D	Blank, R, G, W
				w/Auxiliary Contact	NH1Y-2111- 7 8 11 12					
				w/Alarm Contact	-					
		With	Without	NH1Y-2100F- 7 8 11 12						
			w/Auxiliary Contact	NH1Y-2111F- 7 8 11 12						
			w/Alarm Contact	-						
	Screw Terminal	Without	Without	NH1Y-2100S- 7 8 11 12						
			w/Auxiliary Contact	NH1Y-2111S- 7 8 11 12						
			w/Alarm Contact	-						
		With	Without	NH1Y-2100FS- 7 8 11 12						
			w/Auxiliary Contact	NH1Y-2111FS- 7 8 11 12						
			w/Alarm Contact	-						
Relay Trip Voltage Trip	1	Tab Terminal	Without	Without	NH1Y-1500- 9 11 12	-	-	100V AC 24V DC	Blank, A, C, D	Blank, R, G, W
	2			Without	NH1Y-2500- 9 11 12					
	-			-	-					

NH1L (Rocker Type) Type No.

• Specify a rated current, time delay curve, rated voltage, indicator, rocker indicator, and rocker color in place of **7 8 9 10 11 12**. Package Quantity: 1

Internal Circuit	No. of Poles	Terminal Style	Inertia Delay	Auxiliary Contact Alarm Contact	Type No. (Ordering Type No.)	Designation Code					
						7 Rated Current	8 Time Delay Curve	9 Rated Voltage	10 Indicator	11 Rocker Indication	12 Rocker Color
Series Trip Current Trip	1	Tab Terminal	Without	Without	NH1L-1100- 7 8 10 11 12	0.5A 0.75A 1A 2A 3A 5A 7.5A 10A 15A 20A 25A 30A	AA BA MA AD MD	-	1: Neon 125V AC 50/60Hz 3: LED 6V AC/DC 4: LED 12V AC/DC 5: LED 24V AC/DC 7: LED 48V AC/DC	Blank, A, C, D	Blank, R, G, W
				w/Auxiliary Contact	NH1L-1111- 7 8 10 11 12						
				w/Alarm Contact	-						
		With	Without	NH1L-1100F- 7 8 10 11 12							
			w/Auxiliary Contact	NH1L-1111F- 7 8 10 11 12							
			w/Alarm Contact	-							
	Screw Terminal	Without	Without	NH1L-1100S- 7 8 10 11 12							
			w/Auxiliary Contact	NH1L-1111S- 7 8 10 11 12							
			w/Alarm Contact	-							
	With	Without	NH1L-1100FS- 7 8 10 11 12								
		w/Auxiliary Contact	NH1L-1111FS- 7 8 10 11 12								
		w/Alarm Contact	-								
Series Trip Current Trip	2	Tab Terminal	Without	Without	NH1L-2100- 7 8 10 11 12						
				w/Auxiliary Contact	NH1L-2111- 7 8 10 11 12						
				w/Alarm Contact	-						
		With	Without	NH1L-2100F- 7 8 10 11 12							
			w/Auxiliary Contact	NH1L-2111F- 7 8 10 11 12							
			w/Alarm Contact	-							
	Screw Terminal	Without	Without	NH1L-2100S- 7 8 10 11 12							
			w/Auxiliary Contact	NH1L-2111S- 7 8 10 11 12							
			w/Alarm Contact	-							
	With	Without	NH1L-2100FS- 7 8 10 11 12								
		w/Auxiliary Contact	NH1L-2111FS- 7 8 10 11 12								
		w/Alarm Contact	-								
Relay Trip Voltage Trip	1	Tab Terminal	Without	Without	NH1L-1500- 9 10 11 12	-	-	100V AC 24V DC	1: Neon 125V AC 50/60Hz 3: LED 6V AC/DC 4: LED 12V AC/DC 5: LED 24V AC/DC 7: LED 48V AC/DC	Blank, A, C, D	Blank, R, G, W
	2			Without	NH1L-2500- 9 10 11 12						
	-			-	-						

- Flush Silhouette
- Control Units
- Display Lights
- Display Units
- Safety Products
- Terminal Blocks
- Comm. Terminals
- AS-Interface
- Relays & Timers
- Sockets
- Circuit Protectors
- Power Supplies
- PLCs & SmartRelay
- Operator Interfaces
- Sensors
- Control Stations
- Explosion Protection
- References

NH1 Series Circuit Protectors

NH1V (Lever Type) Type No.

• Specify a rated current, time delay curve, and rated voltage in place of [7] [8] [9]. Package Quantity: 1

Internal Circuit	No. of Poles	Inertia Delay	Auxiliary Contact Alarm Contact	Type No. (Ordering Type No.)	Code for Ordering		
					[7] Rated Current	[8] Time Delay Curve	[9] Rated Voltage
Series Trip Current Trip	1	Without	Without	NH1V-1100- [7] [8]	0.5A 0.75A 1A 2A 3A 5A 7.5A 10A 15A 20A 25A 30A	AA BA MA AD MD	-
			w/Auxiliary Contact	NH1V-1111- [7] [8]			
			w/Alarm Contact	NH1V-1121- [7] [8]			
		With	Without	NH1V-1100F- [7] [8]			
			w/Auxiliary Contact	NH1V-1111F- [7] [8]			
			w/Alarm Contact	NH1V-1121F- [7] [8]			
	2	Without	Without	NH1V-2100- [7] [8]			
			w/Auxiliary Contact	NH1V-2111- [7] [8]			
			w/Alarm Contact	NH1V-2121- [7] [8]			
		With	Without	NH1V-2100F- [7] [8]			
			w/Auxiliary Contact	NH1V-2111F- [7] [8]			
			w/Alarm Contact	NH1V-2121F- [7] [8]			
	3	Without	Without	NH1V-3100- [7] [8]			
			w/Auxiliary Contact	NH1V-3111- [7] [8]			
			w/Alarm Contact	NH1V-3121- [7] [8]			
With		Without	NH1V-3100F- [7] [8]				
		w/Auxiliary Contact	NH1V-3111F- [7] [8]				
		w/Alarm Contact	NH1V-3121F- [7] [8]				
Relay Trip Voltage Trip	1	Without	Without	NH1V-1500- [9]	-	-	100V AC 24V DC
	2		Without	NH1V-2500- [9]			
	3		Without	NH1V-3500- [9]			

Internal Circuits and Terminal Arrangements

Type	Series Trip (Current Trip)	Series Trip (w/auxiliary contact)	Series Trip (w/alarm contact)	Relay Trip (Voltage Trip)	Dual Coil Type Series Trip + Relay Trip (Voltage Trip)												
NH1S																	
NH1Y			-		-												
NH1L w/indicator			-		-												
Appearance (Rear View)																	
<p>Note: The 2-pole type with auxiliary or alarm contact has the contacts on the left side as viewed from the front. The 3-pole type with auxiliary and alarm contacts has the contacts on the center. See the dimensional drawings for the terminal arrangement.</p> <p>• Wiring Example</p> <p>• Lead Wires for Neon and LED Indicators:</p> <table border="1"> <thead> <tr> <th>Lead Wire</th> <th>Color</th> <th>Neon</th> <th>LED</th> </tr> </thead> <tbody> <tr> <td>Lead wire A</td> <td>Red</td> <td>AC</td> <td>Positive</td> </tr> <tr> <td>Lead wire B</td> <td>Black</td> <td>AC</td> <td>Negative</td> </tr> </tbody> </table>						Lead Wire	Color	Neon	LED	Lead wire A	Red	AC	Positive	Lead wire B	Black	AC	Negative
Lead Wire	Color	Neon	LED														
Lead wire A	Red	AC	Positive														
Lead wire B	Black	AC	Negative														

•NH1V

Type	Series Trip (Current Trip)	Series Trip (w/auxiliary contact)	Series Trip (w/alarm contact)	Relay Trip (Voltage Trip)
NH1V				
Appearance				

Note: See the dimensional drawings for the terminal arrangement.

- Flush Silhouette
- Control Units
- Display Lights
- Display Units
- Safety Products
- Terminal Blocks
- Comm. Terminals
- AS-Interface
- Relays & Timers
- Sockets
- Circuit Protectors
- Power Supplies
- PLCs & SmartRelay
- Operator Interfaces
- Sensors
- Control Stations
- Explosion Protection
- References

NH1 Series Circuit Protectors

Overcurrent - Time Delay Characteristics (sec at 25°C) [at vertical mounting]

For	Time Delay Curve	Percent of Rated Current							
		100%	125%	150%	200%	400%	600%	800%	1000%
AC 50/60Hz	AA	No Trip	12-180	6-70	2-25	0.15-3.5	0.005-0.3	0.004-0.13	0.004-0.04
	BA	No Trip	0.7-15	0.3-4	0.1-1.3	0.02-0.25	0.006-0.13	0.003-0.07	0.003-0.04
	MA	No Trip	50-800	20-300	5.5-110	0.3-17	0.008-2.5	0.004-0.5	0.004-0.1
DC	AD	No Trip	10-180	6-75	2.6-30	0.5-7	0.015-3	0.004-0.8	0.003-0.1
	MD	No Trip	70-800	25-300	10-100	1.2-20	0.02-5	0.004-0.65	0.003-0.1

Note: Circuit protectors with inertia delay may have a slightly longer time delay at 400% or higher.

•Dual Coil Type

For	Time Delay Curve	Percent of Rated Current							
		100%	125%	150%	200%	400%	600%	800%	1000%
AC 50/60Hz	AA	No trip	6-500	2-150	0.7-40	0.1-8	0.005-1.2	0.003-0.2	0.003-0.15
	BA	No trip	0.7-60	0.25-20	0.07-6	0.013-1.2	0.004-0.4	0.003-0.2	0.003-0.15
	MA	No trip	50-800	15-600	6-250	0.4-40	0.06-3	0.003-0.2	0.003-0.15
DC	AD	No trip	10-180	1.5-100	0.6-30	0.1-7	0.015-3	0.004-0.8	0.003-0.1
	MD	No trip	70-800	14-600	5-200	0.8-40	0.007-20	0.003-4	0.003-0.1

Note: Circuit protectors with inertia delay may have a slightly longer time delay at 400% or higher.

Time Delay Curves

Note: The dashed lines show dual coil type.

For AC

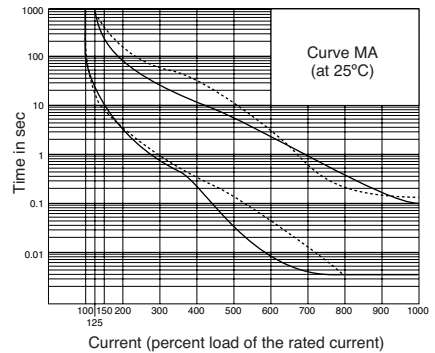
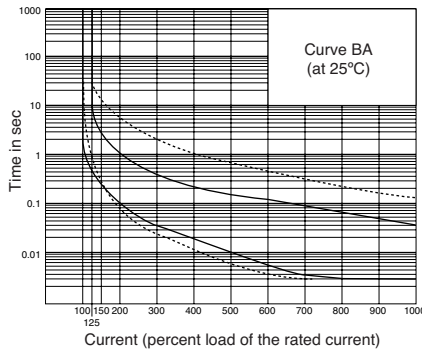
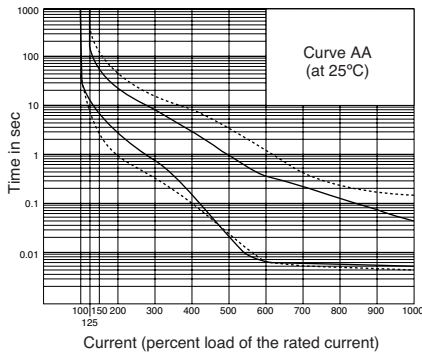

For DC

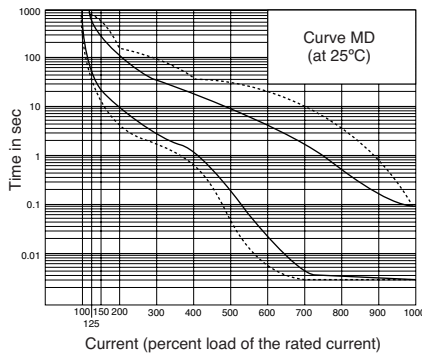
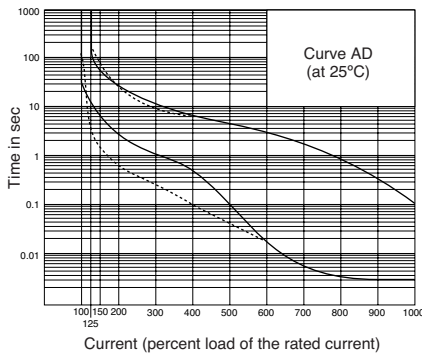

Time Delay Curve and Ambient Temperature

Since NH1 series circuit protectors employ an electromagnetic tripping system, the rated current (trip current) is not affected by ambient temperatures but the time delay varies with the oil viscosity in the oil dash pot. Lower oil viscosity at higher temperatures results in shorter delay, whereas at lower temperatures the delay will be prolonged. The time delay curves on the preceding page are at 25°C. With reference to these curves, time delays can be corrected.

Temperature Correction Curve

The time delay curves are at 25°C. With reference to the following figure, time delays can be corrected.

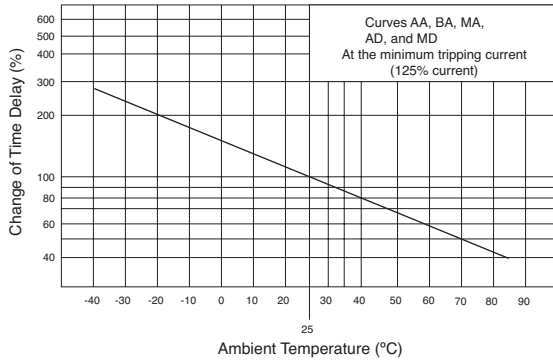

Circuit Protector with Inertia Delay

1. Circuit protectors equipped with inertia delay do not respond to high inrush currents caused by transformer or lamp loads, but perform the specified interruption on the subsequent overcurrents.
2. Inertia delay is designed not to trip on a pulse of 1500% the rated current for a duration of 10 ms.

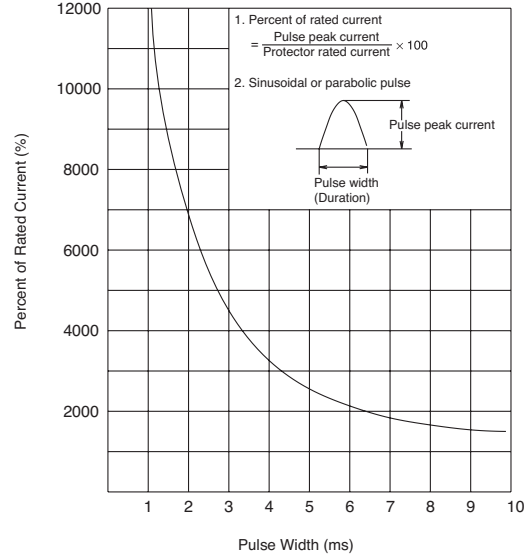

Impedance and Coil Resistance

• Series Trip Type [Current Trip Type]

Rated Current	For AC 50/60Hz Impedance (Ω)		Rated Current	For DC Resistance (Ω)	
	Curves AA, BA, and MA	Curves AD and MD		Curves AA, BA, and MA	Curves AD and MD
0.5A	3.36	3.24	7.5A	0.018	0.017
0.75A	1.49	1.45	10A	0.012	0.012
1A	0.92	0.90	15A	0.0068	0.0066
2A	0.21	0.21	20A	0.0048	0.0048
2.5A	0.13	0.13	25A	0.0043	0.0043
3A	0.092	0.09	30A	0.0041	0.0036
5A	0.036	0.036			

Note: Tolerance: ±25% (up to 5A), ±50% (7.5A or higher)

• Relay Trip Type [Voltage Trip Type]

Rated Voltage	For AC 50/60Hz Impedance (Ω)	For DC Resistance (Ω)
100V AC	1350	—
24V DC	—	248

• Dual Coil Type [Current Trip Type]

Rated Current	For AC 50/60Hz Impedance (Ω)	
	Curves AA, BA, and MA	Curves AD and MD
2A	0.308	0.307
3A	0.129	0.127
5A	0.0509	0.0518
7.5A	0.0249	0.0245
10A	0.0150	0.0150
15A	0.0084	0.0080

Note: Tolerance: ±25% (up to 5A), ±50% (7.5A or higher)

[Voltage Trip Type]

Rated Voltage	For AC 50/60Hz Impedance (Ω)	For DC Resistance (Ω)
100V AC	321	—
24V DC	—	15.7

Note: Tolerance: ±25%

• Voltage Drop Due to Coil Resistance or Impedance

The internal resistance or impedance of a circuit protector tends to be larger for a smaller rated current. Therefore, when circuit protectors of a small rated current are used, voltage drop should be taken into consideration. Internal resistance also varies with time delay curves in spite of the same rated current, which should also be considered during installation.

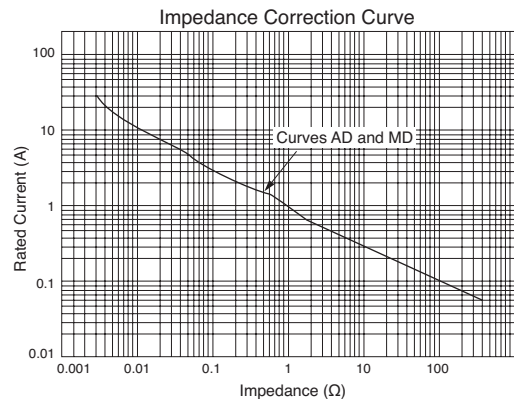
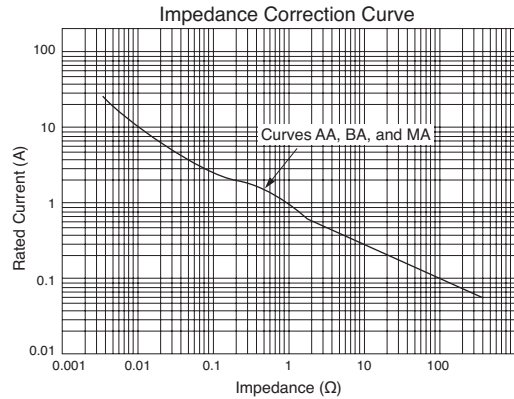

Flush Silhouette

Control Units

Display Lights

Display Units

Safety Products

Terminal Blocks

Comm. Terminals

AS-Interface

Relays & Timers

Sockets

Circuit Protectors

Power Supplies

PLCs & SmartRelay

Operator Interfaces

Sensors

Control Stations

Explosion Protection

References

NH1 Series Circuit Protectors

Dimensions

[NH1S]

•1-pole Type

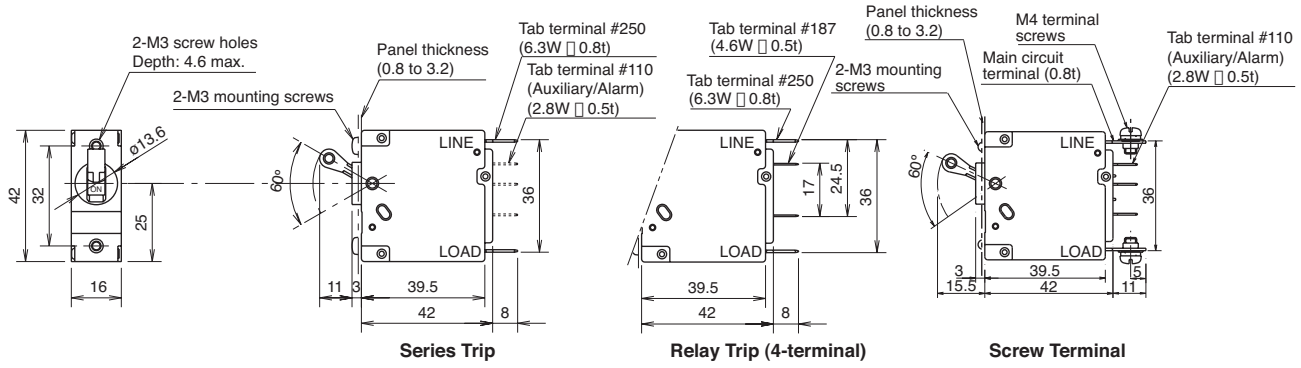

•2-pole Type

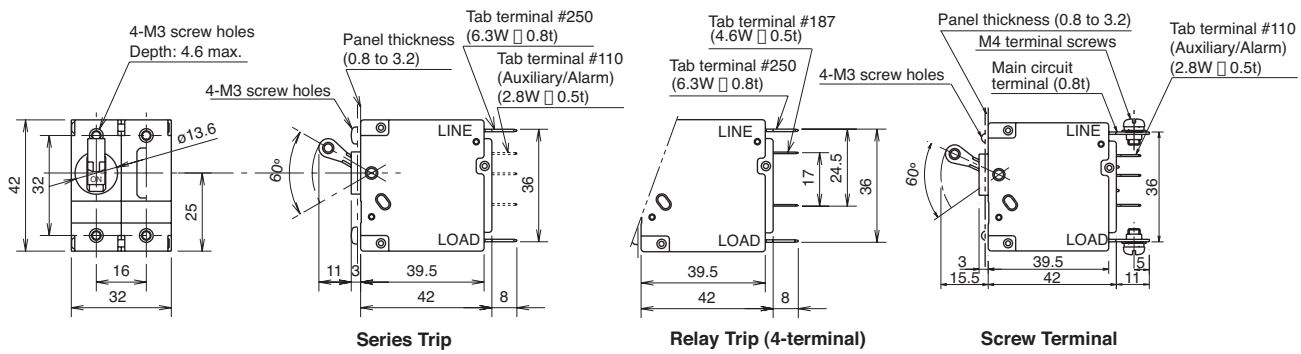

•3-pole Type

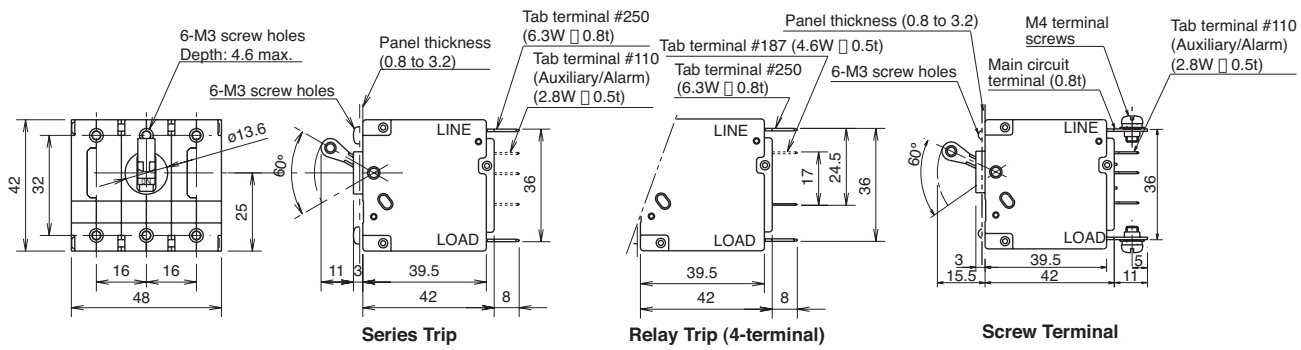

[NH1Y • NH1L]

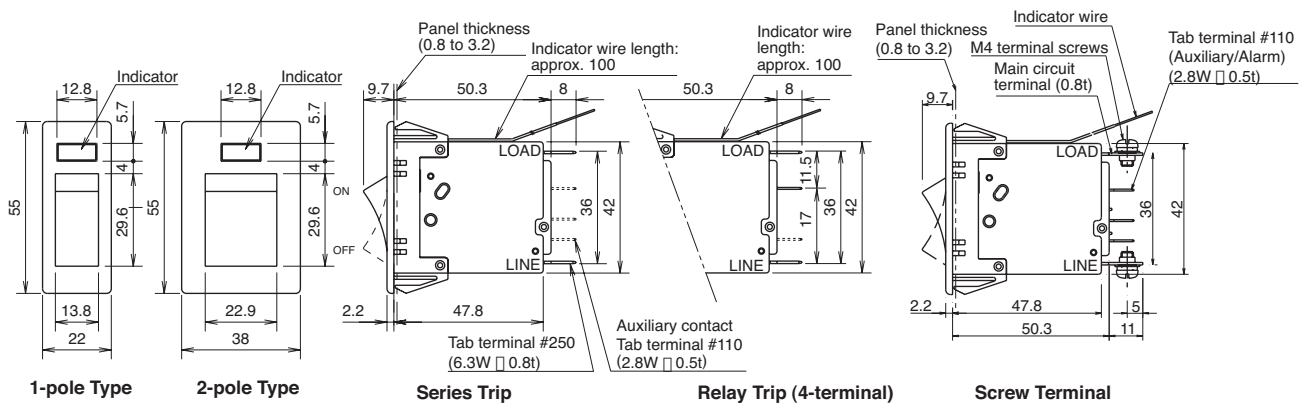

All dimensions in mm.

Dimensions

[NH1V]

•1-pole Type

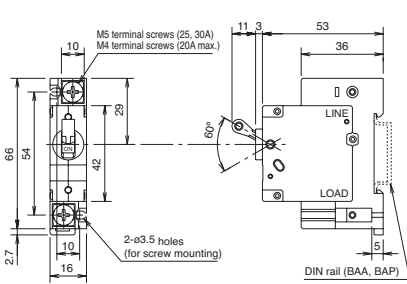

Series Trip

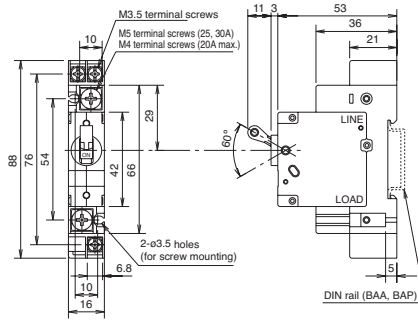

Series Trip (Auxiliary/Alarm Contacts)

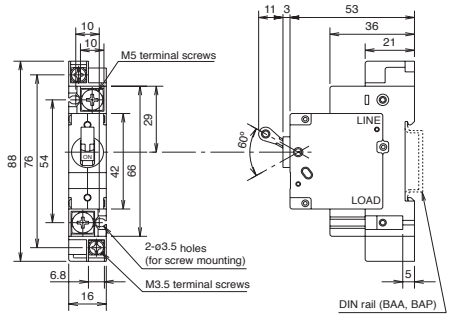

Relay Trip

•2-pole Type

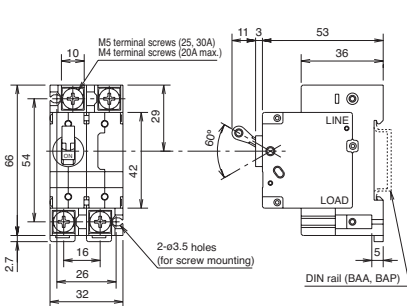

Series Trip

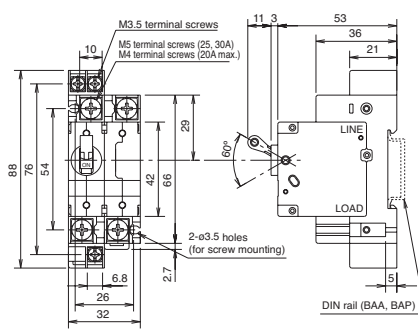

Series Trip (Auxiliary/Alarm Contacts)

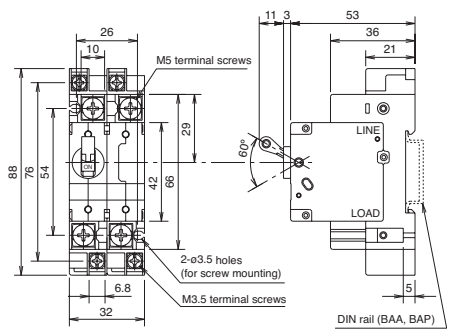

Relay Trip

•3-pole Type

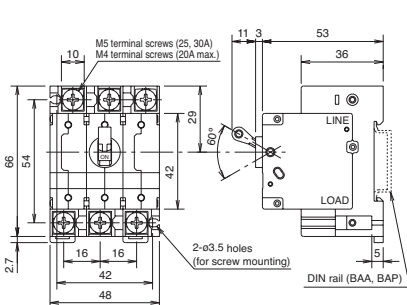

Series Trip

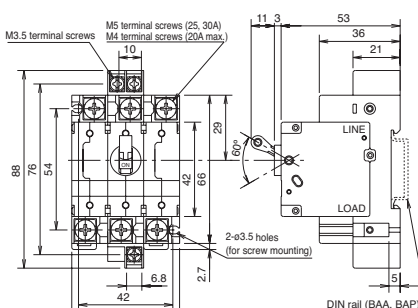

Series Trip (Auxiliary/Alarm Contacts)

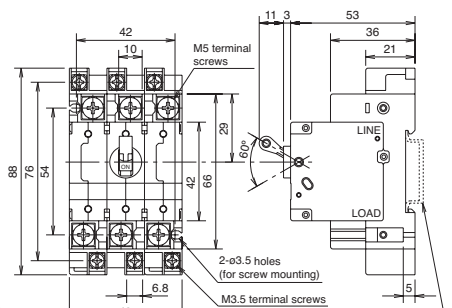

Relay Trip

Accessories (Optional)

Product / Appearance	Type No.	Ordering Type No.	Package Quantity	Description / Dimensions
<p>• Terminal Cover (for main terminals) for NH1V</p> <p>Material: Polyamide</p>	NH9Z-A	NH9Z-APN02	2	<p>Two pieces are required for 1 unit.</p>
<p>• Terminal Cover (for main/auxiliary terminals) for NH1V</p> <p>Material: Polyamide</p>	NH9Z-B	NH9Z-BPN02	2	<p>Two pieces are required for 1 unit.</p>

- Flush Silhouette
- Control Units
- Display Lights
- Display Units
- Safety Products
- Terminal Blocks
- Comm. Terminals
- AS-Interface
- Relays & Timers
- Sockets
- Circuit Protectors
- Power Supplies
- PLCs & SmartRelay
- Operator Interfaces
- Sensors
- Control Stations
- Explosion Protection
- References

NH1 Series Circuit Protectors

Mounting Hole Layout

[NH1S]

•1-pole Type

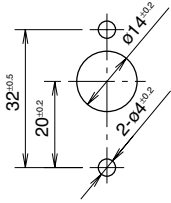

•2-pole Type

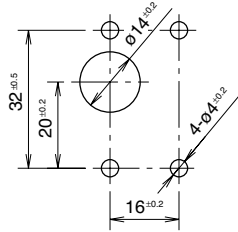

•3-pole Type

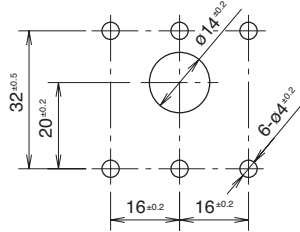

[NH1Y • NH1L]

•1-pole Type

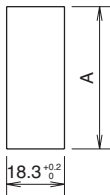

•2-pole Type

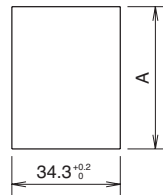

• Determine the dimension A within the panel thickness using the following formula:

$$\text{Dimension A (mm)} = 50.4 + (\text{Panel thickness} - 0.8) \times 0.87$$

Applicable panel thickness: 0.8 to 3.2 mm

• Panel Mounting Screw Length

Select the screw length with reference to the following table.

Panel thickness (mm)		0.8	1.0	1.2	1.4	1.6	1.8	2.0	2.3	2.6	3.2
Without washer		5	5	5	6	6	6	6	6	7	7
With plain washer (0.5 mm thick)		5	6	6	6	6	6	7	7	7	8
With spring washer (0.7 mm thick)		6	6	6	6	6	7	7	7	7	8
With plain washer (0.5 mm thick) and spring washer (0.7 mm thick)		6	6	7	7	7	7	7	8	8	8

M3 screw mounting
Tightening torque: 0.5 N·m minimum
Tightening strength: 0.7 N·m

[NH1V]

•1-pole Type

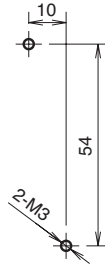

•2-pole Type

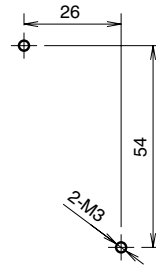

•3-pole Type

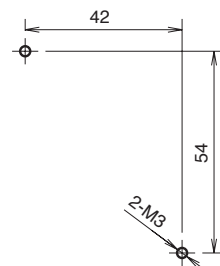

• Installation Angle

Tripping method is hydraulic magnetic. Minimum operating current varies with installation angle because operating currents are influenced by the weight of movable iron core. With reference to the following figure, correct the rated current.

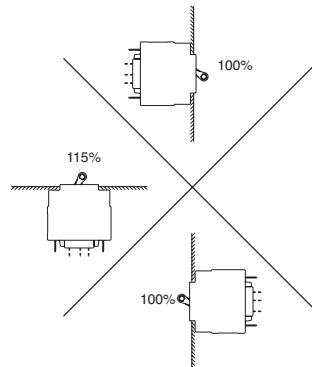

Note 1: The rated current does not change depending on the installation angle.
Note 2: The minimum operating current is calculated from the following formula:
(Minimum operating current) = (Rated current) × 125% × (Correction factor by installation angle)

Instructions

One-pole type circuit protectors cannot be combined to make 2- or 3-pole units due to their characteristics. Order multi-pole types from IDEC.

• Recommended Soldering Conditions

Solder the main terminal at a temperature of 390°C within 10 seconds using a 60W soldering iron.

Solder the auxiliary/alarm terminal at a temperature of 350°C within 3 seconds using a 60W soldering iron. (Sn-Ag-Cu lead-free solder is recommended.)

When soldering, do not touch the circuit protector housing, auxiliary and alarm contacts with the soldering iron, and do not bend the terminals or pull the wires.

Check your actual soldering conditions before soldering.

• Main Circuit Terminal: Screw terminal

1. Applicable wire size	1.25 to 5.5 mm ²
2. Applicable crimping terminal	R1.25-4 to R5.5-4
3. No. of crimping terminal	1
4. Tightening torque	1.0 to 1.2 N·m
5. Tensile strength (Static 1 minute)	Axial direction: 80N Transverse direction: 20N

Thrust force (screw pressing load) in screw tightening should be 29N or less. The screw driver may slip out depending on the shape type and conditions. In this case, hold the terminal with a tool and tighten the screw by applying a thrust force of about 50N without deforming the terminal.

NRA Series Circuit Protectors

Best Selling Circuit Protectors

Wide selection of applications ranging from computers to office and factory automation

- Available with inertia delay
- Available with auxiliary contact or alarm contact
- Hydraulic-magnetic tripping system
- Safe trip-free mechanism
- Vibration-proof design
- Variety of mounting methods
- IEC(IEC 60934) compliant
- Available in tab-terminal type and screw-terminal type suited for crimping-terminal wiring.

Applicable Standards	Certification Mark	Certification Organization / File No.
UL1077 CSA C22.2 No. 235 (Note 1)		UL/c-UL File No. E68029
EN60934 (VDE0642) (Note 2)		No. 116381
GB17701		CCC No. 2005010309151792
Electrical Appliance and Material Safety Law Technical Standard		JET

For details, see the list of standard certified products in the back of this catalog.
 Note 1: All standard models
 Note 2: All models

Specifications

Type	NRAS	NRAN	NRAR
Operator Style	Lever	Lever	Rocker (Non-illuminated, Illuminated)
Protection Method	Hydraulic-magnetic tripping system		
Internal Circuit	Series trip (current trip) Relay trip (voltage trip) Series trip (current trip) with auxiliary contacts Series trip (current trip) with alarm contacts		
No. of poles	1, 2, 3 poles		1 pole
Rated Voltage	250V AC 50/60Hz, 65V DC		
Minimum Applicable Load	24V AC/DC, 100 mA (reference value)		
Rated Current	Current trip: 0.3A, 0.5A, 0.75A, 1A, 2A, 3A, 5A, 7.5A, 10A, 15A, 20A, 25A, 30A		
Trip Voltage (Voltage trip)	Rated voltage: 24V DC (operating at 90% of the rated voltage or higher, at 25°C) Voltage application duration: 1 sec maximum Trip time: 0.05 sec maximum (at the rated voltage)		
Rated Interrupting Capacity	250V AC 50/60Hz 1000A, 65V DC 1000A		
Auxiliary Contact Alarm Contact	SPDT microswitch 250V AC 5A (resistive load), 50V DC 1A (resistive load)		
Reference Temperature	+25°C		
Operating Temperature	-40 to +85°C (no freezing)		
Operating Humidity	45 to 85% RH (no condensation)		
Insulation Resistance	100 MΩ minimum (500V DC megger)		
Dielectric Strength	2000V AC for 1 minute (between live part and ground, between terminals of different poles, between terminals of the same poles when main contacts are open, between main circuit and auxiliary contact)		
Vibration Resistance	100 m/s ² (10 to 100Hz)		
Shock Resistance	1000 m/s ²		
Life	Over 10,000 operations (6 operations per minute)		
Terminal Style	Main terminal: Tab terminal #250, M4 screw terminal Auxiliary contact/Alarm contact: Tab terminal #110		
Weight (Approx.) (NRAS series trip)	1-pole type: 60g 2-pole type: 125g 3-pole type: 190g		

Indicator Ratings (Illuminated rocker unit)

Indicator	Rated Voltage
Neon	100 to 110V AC, 50/60Hz 200 to 220V AC, 50/60Hz
LED	4 to 8V DC

NRAS

Mounting hole
ø16

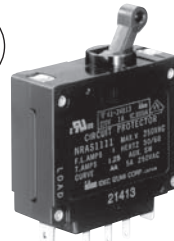

NRAN

Mounting hole
32-19.6

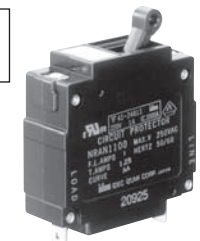

NRAR

Mounting hole
32-19.6



Rocker



Illuminated Rocker
(with Neon lamp)

Standard Color

Housing	Black		
Lever (NRAS, NRAN)	Black with white letters, ON-OFF, I/O		
Rocker Color, Indicator Color (NRAR)	Non-illuminated	Rocker Color	Indicator Color
	with Neon lamp	Opaque white	–
		Transparent red	Red

Flush Silhouette

Control Units

Display Lights

Display Units

Safety Products

Terminal Blocks

Comm. Terminals

AS-Interface

Relays & Timers

Sockets

Circuit Protectors

Power Supplies

PLCs & SmartRelay

Operator Interfaces

Sensors

Control Stations

Explosion Protection

References

NRA Series Circuit Protectors

Type No. Development

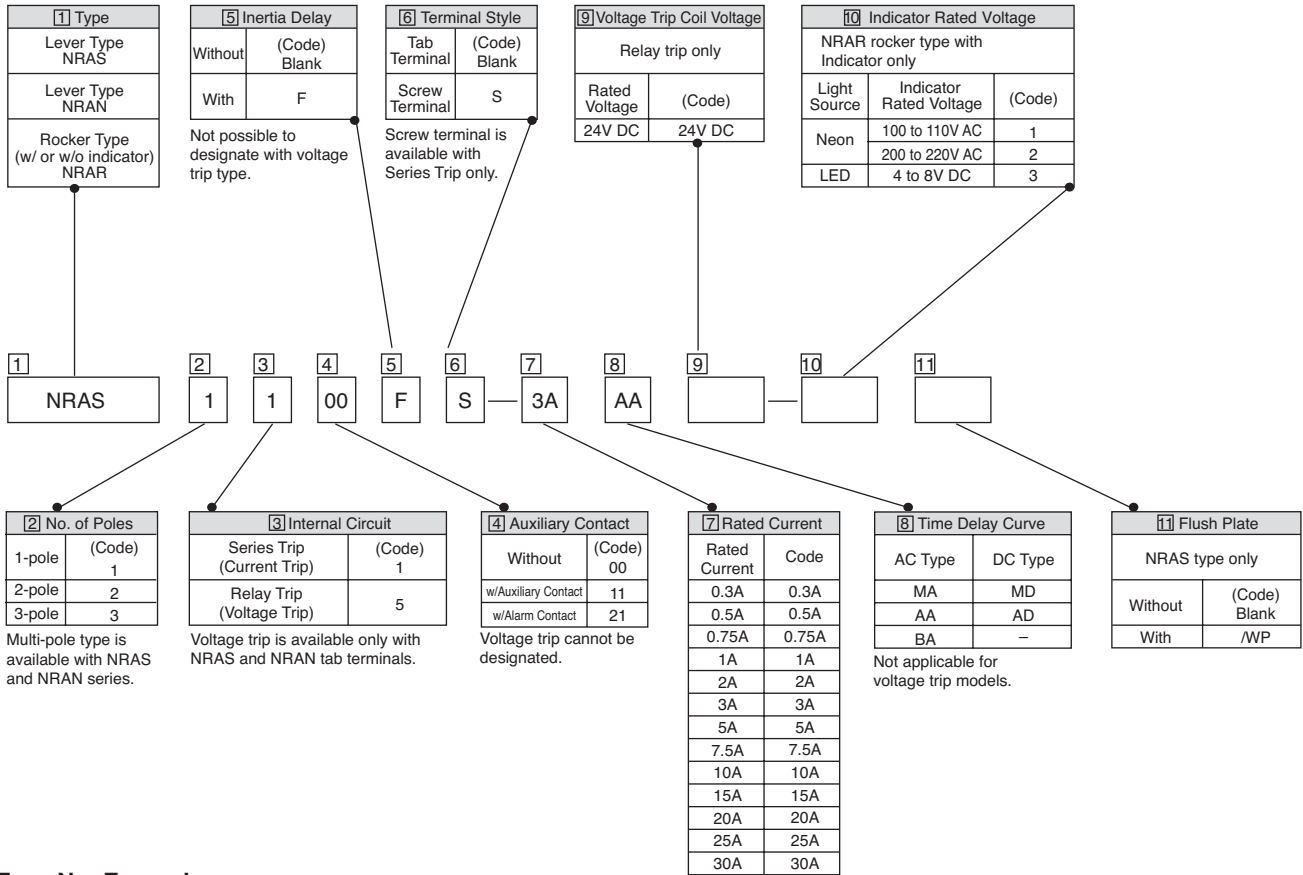

Type No. Examples

(1) Circuit protector: Lever type

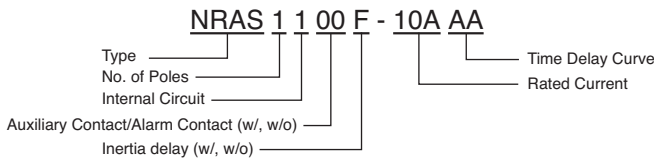

(2) Circuit Protector: Illuminated rocker type

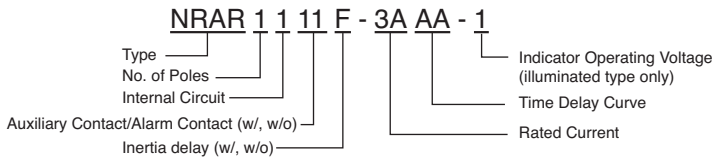

NRAS (Lever Type)

Specify a rated current, time delay curve, and rated voltage in place of [7] [8] [9].

Package Quantity: 1

Internal Circuit	No. of Poles	Terminal Style	Inertia Delay	Flush Plate	Auxiliary Contact Alarm Contact	Type No. (Ordering Type No.)	Designation Code		
							[7] Rated Current	[8] Time Delay Curve	[9] Rated Voltage
Series Trip Current Trip	1	Tab Terminal	Without	Without	Without	NRAS1100- [7] [8]	0.3A 0.5A 0.75A 1A 2A 3A 5A 7.5A 10A 15A 20A 25A 30A	AA BA MA AD MD	-
					w/Auxiliary Contact	NRAS1111- [7] [8]			
					w/Alarm Contact	NRAS1121- [7] [8]			
				With	Without	NRAS1100- [7] [8] /WP			
					w/Auxiliary Contact	NRAS1111- [7] [8] /WP			
					w/Alarm Contact	NRAS1121- [7] [8] /WP			
			With	Without	Without	NRAS1100F- [7] [8]			
					w/Auxiliary Contact	NRAS1111F- [7] [8]			
					w/Alarm Contact	NRAS1121F- [7] [8]			
				With	Without	NRAS1100F- [7] [8] /WP			
					w/Auxiliary Contact	NRAS1111F- [7] [8] /WP			
					w/Alarm Contact	NRAS1121F- [7] [8] /WP			
		Screw Terminal	Without	Without	Without	NRAS1100S- [7] [8]			
					w/Auxiliary Contact	NRAS1111S- [7] [8]			
					w/Alarm Contact	NRAS1121S- [7] [8]			
				With	Without	NRAS1100S- [7] [8] /WP			
					w/Auxiliary Contact	NRAS1111S- [7] [8] /WP			
					w/Alarm Contact	NRAS1121S- [7] [8] /WP			
			With	Without	Without	NRAS1100FS- [7] [8]			
					w/Auxiliary Contact	NRAS1111FS- [7] [8]			
					w/Alarm Contact	NRAS1121FS- [7] [8]			
				With	Without	NRAS1100FS- [7] [8] /WP			
					w/Auxiliary Contact	NRAS1111FS- [7] [8] /WP			
					w/Alarm Contact	NRAS1121FS- [7] [8] /WP			
Series Trip Current Trip	2	Tab Terminal	Without	Without	Without	NRAS2100- [7] [8]	0.3A 0.5A 0.75A 1A 2A 3A 5A 7.5A 10A 15A 20A 25A 30A	AA BA MA AD MD	-
					w/Auxiliary Contact	NRAS2111- [7] [8]			
					w/Alarm Contact	NRAS2121- [7] [8]			
				With	Without	NRAS2100- [7] [8] /WP			
					w/Auxiliary Contact	NRAS2111- [7] [8] /WP			
					w/Alarm Contact	NRAS2121- [7] [8] /WP			
			With	Without	Without	NRAS2100F- [7] [8]			
					w/Auxiliary Contact	NRAS2111F- [7] [8]			
					w/Alarm Contact	NRAS2121F- [7] [8]			
				With	Without	NRAS2100F- [7] [8] /WP			
					w/Auxiliary Contact	NRAS2111F- [7] [8] /WP			
					w/Alarm Contact	NRAS2121F- [7] [8] /WP			
		Screw Terminal	Without	Without	Without	NRAS2100S- [7] [8]			
					w/Auxiliary Contact	NRAS2111S- [7] [8]			
					w/Alarm Contact	NRAS2121S- [7] [8]			
				With	Without	NRAS2100S- [7] [8] /WP			
					w/Auxiliary Contact	NRAS2111S- [7] [8] /WP			
					w/Alarm Contact	NRAS2121S- [7] [8] /WP			
			With	Without	Without	NRAS2100FS- [7] [8]			
					w/Auxiliary Contact	NRAS2111FS- [7] [8]			
					w/Alarm Contact	NRAS2121FS- [7] [8]			
				With	Without	NRAS2100FS- [7] [8] /WP			
					w/Auxiliary Contact	NRAS2111FS- [7] [8] /WP			
					w/Alarm Contact	NRAS2121FS- [7] [8] /WP			

- Flush Silhouette
- Control Units
- Display Lights
- Display Units
- Safety Products
- Terminal Blocks
- Comm. Terminals
- AS-Interface
- Relays & Timers
- Sockets
- Circuit Protectors
- Power Supplies
- PLCs & SmartRelay
- Operator Interfaces
- Sensors
- Control Stations
- Explosion Protection
- References

NRA Series Circuit Protectors

NRAS (Lever Type)

Specify a rated current, time delay curve, and rated voltage in place of [7] [8] [9].

Package Quantity: 1

Internal Circuit	No. of Poles	Terminal Style	Inertia Delay	Flush Plate	Auxiliary Contact Alarm Contact	Type No. (Ordering Type No.)	Designation Code		
							[7] Rated Current	[8] Time Delay Curve	[9] Rated Voltage
Series Trip Current Trip	3	Tab Terminal	Without	Without	Without	NRAS300- [7] [8]	0.3A 0.5A 0.75A 1A 2A 3A 5A 7.5A 10A 15A 20A 25A 30A	AA BA MA AD MD	-
					w/Auxiliary Contact	NRAS3111- [7] [8]			
					w/Alarm Contact	NRAS3121- [7] [8]			
			With	Without	Without	NRAS3100F- [7] [8]			
					w/Auxiliary Contact	NRAS3111F- [7] [8]			
					w/Alarm Contact	NRAS3121F- [7] [8]			
		Screw Terminal	Without	Without	Without	NRAS3100S- [7] [8]			
					w/Auxiliary Contact	NRAS3111S- [7] [8]			
					w/Alarm Contact	NRAS3121S- [7] [8]			
			With	Without	Without	NRAS3100FS- [7] [8]			
					w/Auxiliary Contact	NRAS3111FS- [7] [8]			
					w/Alarm Contact	NRAS3121FS- [7] [8]			
Relay Trip Voltage Trip	1	Tab Terminal	Without	Without	Without	NRAS1500- [9]	-	-	24V DC
	2				Without	NRAS2500- [9]			
	3				Without	NRAS3500- [9]			

NRAN (Lever Type)

Specify a rated current, time delay curve, and rated voltage in place of [7] [8] [9].

Package Quantity: 1

Series Trip Current Trip	No. of Poles	Terminal Style	Inertia Delay	Auxiliary Contact Alarm Contact	Type No. (Ordering Type No.)	Designation Code		
						[7] Rated Current	[8] Time Delay Curve	[9] Rated Voltage
Series Trip Current Trip	1	Tab Terminal	Without	Without	NRAN1100- [7] [8]	0.3A 0.5A 0.75A 1A 2A 3A 5A 7.5A 10A 15A 20A 25A 30A	AA BA MA AD MD	-
				w/Auxiliary Contact	NRAN1111- [7] [8]			
				w/Alarm Contact	NRAN1121- [7] [8]			
		With	Without	NRAN1100F- [7] [8]				
			w/Auxiliary Contact	NRAN1111F- [7] [8]				
			w/Alarm Contact	NRAN1121F- [7] [8]				
	Screw Terminal	Without	Without	NRAN1100S- [7] [8]				
			w/Auxiliary Contact	NRAN1111S- [7] [8]				
			w/Alarm Contact	NRAN1121S- [7] [8]				
		With	Without	NRAN1100FS- [7] [8]				
			w/Auxiliary Contact	NRAN1111FS- [7] [8]				
			w/Alarm Contact	NRAN1121FS- [7] [8]				
Series Trip Current Trip	2	Tab Terminal	Without	Without	NRAN2100- [7] [8]	0.3A 0.5A 0.75A 1A 2A 3A 5A 7.5A 10A 15A 20A 25A 30A	AA BA MA AD MD	-
				w/Auxiliary Contact	NRAN2111- [7] [8]			
				w/Alarm Contact	NRAN2121- [7] [8]			
		With	Without	NRAN2100F- [7] [8]				
			w/Auxiliary Contact	NRAN2111F- [7] [8]				
			w/Alarm Contact	NRAN2121F- [7] [8]				
	Screw terminal	Without	Without	NRAN2100S- [7] [8]				
			w/Auxiliary Contact	NRAN2111S- [7] [8]				
			w/Alarm Contact	NRAN2121S- [7] [8]				
		With	Without	NRAN2100FS- [7] [8]				
			w/Auxiliary Contact	NRAN2111FS- [7] [8]				
			w/Alarm Contact	NRAN2121FS- [7] [8]				
Series Trip Current Trip	3	Tab terminal	Without	Without	NRAN3100- [7] [8]	0.3A 0.5A 0.75A 1A 2A 3A 5A 7.5A 10A 15A 20A 25A 30A	AA BA MA AD MD	-
				w/Auxiliary Contact	NRAN3111- [7] [8]			
				w/Alarm Contact	NRAN3121- [7] [8]			
		With	Without	NRAN3100F- [7] [8]				
			w/Auxiliary Contact	NRAN3111F- [7] [8]				
			w/Alarm Contact	NRAN3121F- [7] [8]				
	Screw Terminal	Without	Without	NRAN3100S- [7] [8]				
			w/Auxiliary Contact	NRAN3111S- [7] [8]				
			w/Alarm Contact	NRAN3121S- [7] [8]				
		With	Without	NRAN3100FS- [7] [8]				
			w/Auxiliary Contact	NRAN3111FS- [7] [8]				
			w/Alarm Contact	NRAN3121FS- [7] [8]				
Relay Trip Voltage Trip	1	Tab Terminal	Without	Without	NRAN1500- [9]	-	-	24V DC
	2			Without	NRAN2500- [9]			
	3			Without	NRAN3500- [9]			

Flush Silhouette
Control Units
Display Lights
Display Units
Safety Products
Terminal Blocks
Comm. Terminals
AS-Interface
Relays & Timers
Sockets
Circuit Protectors
Power Supplies
PLCs & SmartRelay
Operator Interfaces
Sensors
Control Stations
Explosion Protection
References

NRA Series Circuit Protectors

NRAR (Rocker Type)

Specify a rated current, time delay curve, and indicator rated voltage in place of [7] [8] [10] Package Quantity: 1

Illuminated Type	Internal Circuit	No. of Poles	Terminal Style	Inertia Delay	Auxiliary Contact Alarm Contact	Type No. (Ordering Type No.)	Designation Code								
							[7] Rated Current	[8] Time Delay Curve	[10] Indicator Rated Voltage						
Illuminated	Series Trip Current Trip	1	Tab Terminal	Without	Without	NRAR1000- [7] [8] - [10]	0.3A 0.5A 0.75A 1A 2A 3A 5A 7.5A 10A 15A 20A 25A 30A	AA BA MA AD MD	1: Neon 100 to 110V AC 2: Neon 200 to 220V AC 3: LED 4 to 8V DC						
					w/Auxiliary Contact	NRAR1111- [7] [8] - [10]									
					w/Alarm Contact	NRAR1121- [7] [8] - [10]									
				With	Without	NRAR1100F- [7] [8] - [10]									
					w/Auxiliary Contact	NRAR1111F- [7] [8] - [10]									
					w/Alarm Contact	NRAR1121F- [7] [8] - [10]									
			Screw Terminal	Without	Without	NRAR1100S- [7] [8] - [10]									
					w/Auxiliary Contact	NRAR1111S- [7] [8] - [10]									
					w/Alarm Contact	NRAR1121S- [7] [8] - [10]									
				With	Without	NRAR1100FS- [7] [8] - [10]									
					w/Auxiliary Contact	NRAR1111FS- [7] [8] - [10]									
					w/Alarm Contact	NRAR1121FS- [7] [8] - [10]									
			Non-illuminated	Series Trip Current Trip	1	Tab Terminal				Without	Without	NRAR1100- [7] [8]	0.3A 0.5A 0.75A 1A 2A 3A 5A 7.5A 10A 15A 20A 25A 30A	AA BA MA AD MD	-
											w/Auxiliary Contact	NRAR1111- [7] [8]			
											w/Alarm Contact	NRAR1121- [7] [8]			
										With	Without	NRAR1100F- [7] [8]			
w/Auxiliary Contact	NRAR1111F- [7] [8]														
w/Alarm Contact	NRAR1121F- [7] [8]														
Screw Terminal	Without	Without				NRAR1100S- [7] [8]									
		w/Auxiliary Contact				NRAR1111S- [7] [8]									
		w/Alarm Contact				NRAR1121S- [7] [8]									
	With	Without				NRAR1100FS- [7] [8]									
		w/Auxiliary Contact				NRAR1111FS- [7] [8]									
		w/Alarm Contact				NRAR1121FS- [7] [8]									

Internal Circuits

NRAS and NRAN

Series Trip (Current Trip)	Series Trip (Current Trip) With Auxiliary Contact	Series Trip (Current Trip) With Alarm Contact	Relay Trip (Voltage Trip)	

NRAR Dashed lines show the illuminated rocker type.

Series Trip (Current Trip)	Series Trip (Current Trip) With Auxiliary Contact	Series Trip (Current Trip) With Alarm Contact	-	
			-	

Indicator terminals on the illuminated rocker type
Indicator terminals are available only on the series trip type without auxiliary and alarm contacts.
Auxiliary and alarm contacts are provided with color-coded lead wires as shown in the table at right.

Wiring Example

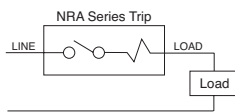

	Indicator	Lead Wire	
		A	B
Neon (for AC)	100 to 110V	White	White
	200 to 220V	Black	Black
LED (for DC)	Positive	Black	-
	Negative	-	White

Overcurrent - Time Delay Characteristics (sec at 25°C)

For	Time Delay Curve	Percent of Rated Current							
		100%	125%	150%	200%	400%	600%	800%	1000%
AC 50/60Hz	AA	No Trip	10-120	6-45	2.2-15	0.3-2	0.05-0.55	0.007-0.13	0.005-0.04
	BA	No Trip	0.75-10	0.45-3.5	0.22-1.3	0.045-0.22	0.012-0.12	0.005-0.06	0.004-0.03
	MA	No Trip	60-900	30-260	9-70	1.5-8	0.18-2.5	0.009-0.25	0.006-0.08
DC	AD	No Trip	10-130	6-55	2.6-20	0.5-3.5	0.12-1.4	0.008-0.1	0.005-0.05
	MD	No Trip	35-400	20-200	7-60	1.3-8	0.2-3	0.01-0.25	0.006-0.08

Note: Circuit protectors with inertia delay may have a slightly longer time delay at 600% or higher.

- Flush Silhouette
- Control Units
- Display Lights
- Display Units
- Safety Products
- Terminal Blocks
- Comm. Terminals
- AS-Interface
- Relays & Timers
- Sockets
- Circuit Protectors
- Power Supplies
- PLCs & SmartRelay
- Operator Interfaces
- Sensors
- Control Stations
- Explosion Protection
- References

NRA Series Circuit Protectors

Time Delay Curves

For AC

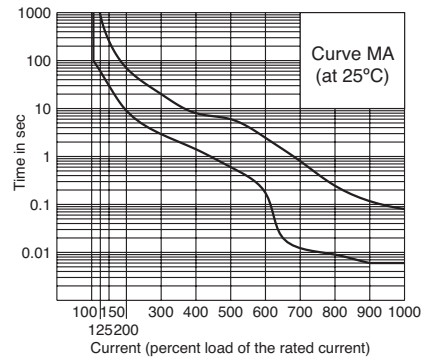
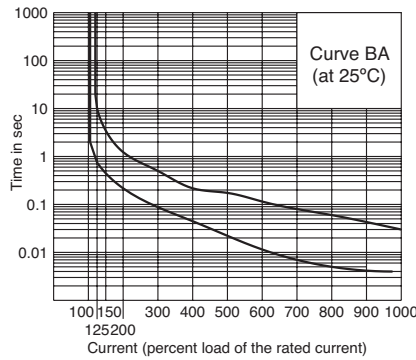
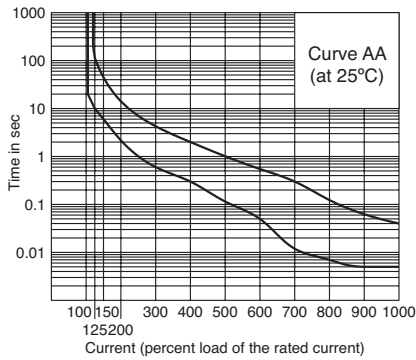

For DC

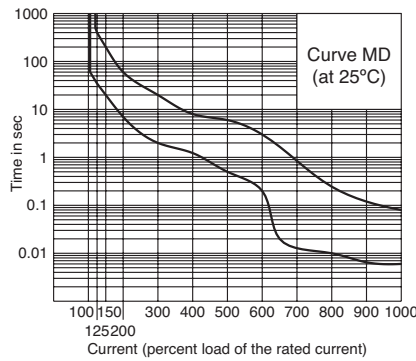
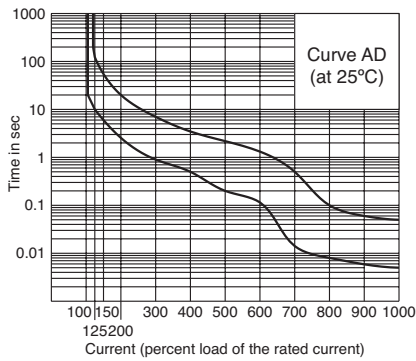

Time Delay Curve and Ambient Temperature

Since the NRA series circuit protectors employ an electromagnetic tripping system, the rated current (trip current) is not affected by the ambient temperatures, but the time delay varies with the oil viscosity in the oil dash pot. Lower oil viscosity at higher temperatures results in shorter delay, whereas at lower temperatures the delay will be prolonged.

The above time delay curves are at 25°C. With reference to these curves, time delays can be corrected.

Temperature Correction Curve

The above time delay curves are at 25°C. With reference to the following figure, time delays can be corrected.

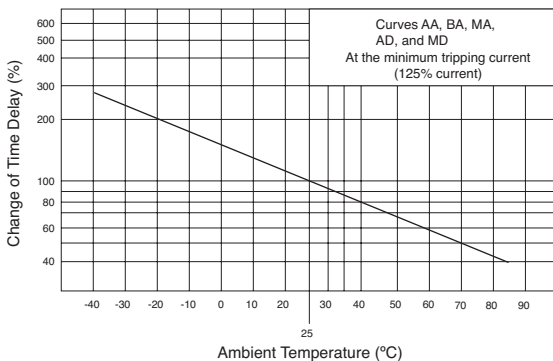

Circuit Protector with Inertia Delay

Circuit protectors equipped with inertia delay do not respond to high inrush currents caused by transformer or lamp loads, but perform the specified interruption on the subsequent overcurrents.

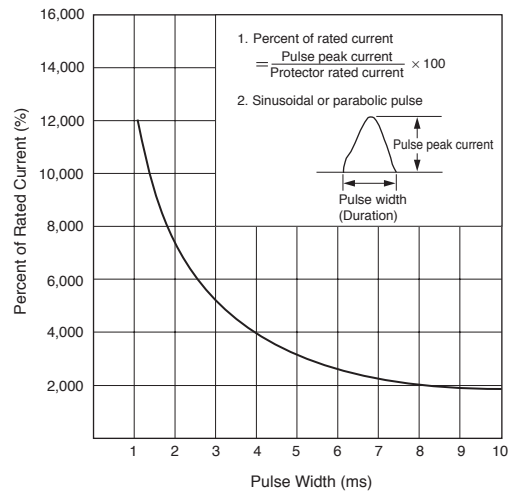

Note: Inertia delay is designed not to trip on a pulse of 20 times the rated current (peak value) for a duration of 8 ms. See the above curve.

All dimensions in mm.

Impedance and Coil Resistance

Series Trip (Current Trip) (at 25°C)

Rated Current	Current Trip	
	For AC 50/60Hz Impedance (Ω)	For DC Resistance (Ω)
	Curves AA, BA, and MA	Curves AD and MD
0.3A	9.82	9.67
0.5A	3.36	3.24
0.75A	1.49	1.45
1A	0.92	0.90
2A	0.21	0.21
3A	0.092	0.09
5A	0.036	0.036
7.5A	0.018	0.017
10A	0.012	0.0012
15A	0.0068	0.0066
20A	0.0048	0.0048
25A	0.0043	0.0043
30A	0.0041	0.0036

Note: Tolerance: ±25% (up to 5A), ±50% (7.5A or higher)

Relay Trip (Voltage Trip) (at 25°C)

Rated Voltage	For DC Resistance (Ω)
24V DC	163

Note: Tolerance: ±25%

Voltage Drop due to Coil Resistance or Impedance

The internal resistance or impedance of a circuit protector tends to be larger for a smaller rated current. Therefore, when circuit protectors of a small rated current are used for a power-supply switch, voltage drop should be taken into consideration. Internal resistance also varies with time delay curves in spite of the same rated current, which should also be considered during installation.

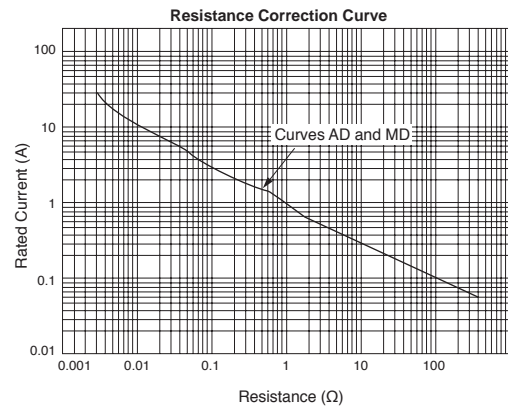
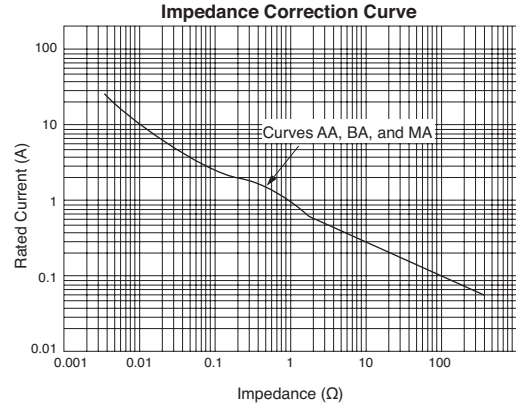

Dimensions

NRAS (Lever Type)

• 1-pole Type

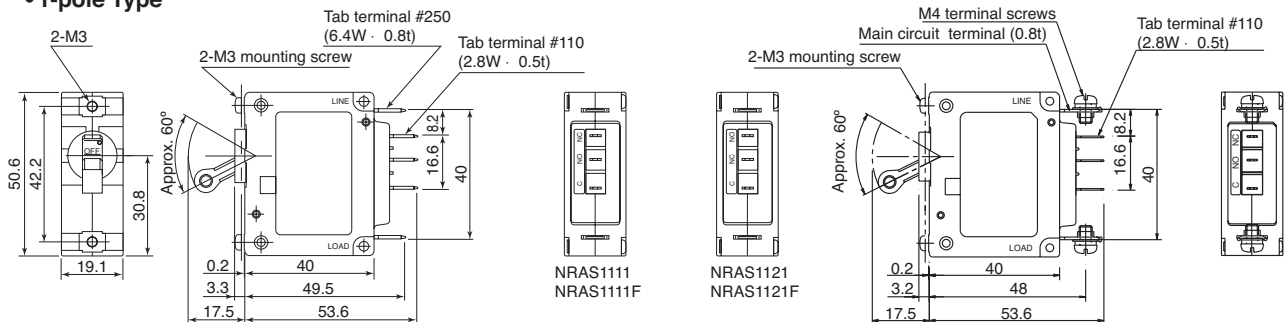

• 2-pole Type

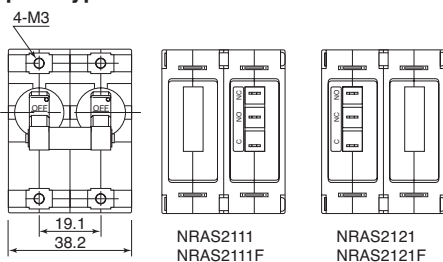

• 3-pole Type

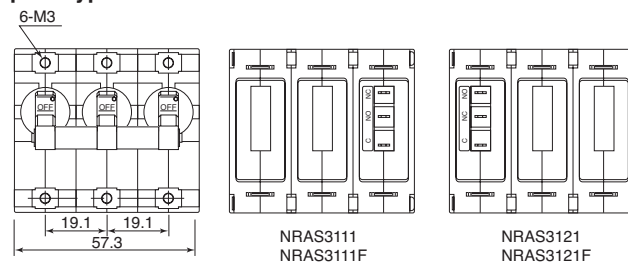

All dimensions in mm.

NRA Series Circuit Protectors

NRAS (Lever Type with Flush Plate)

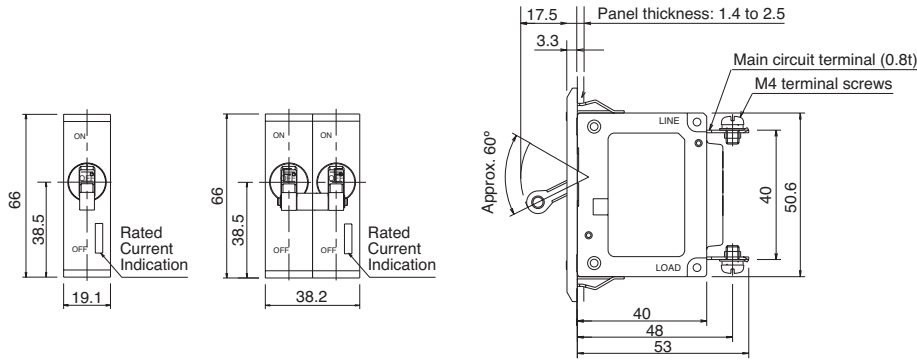

NRAN (Lever Type)

• 1-pole Type

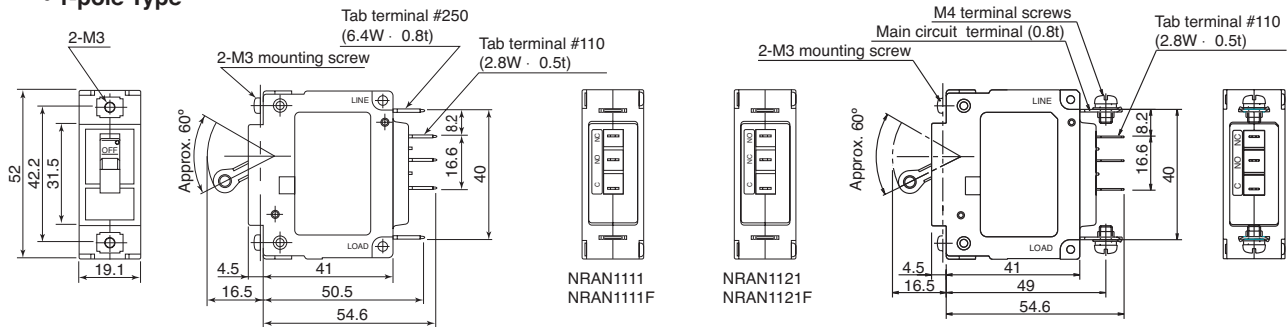

• 2-pole Type

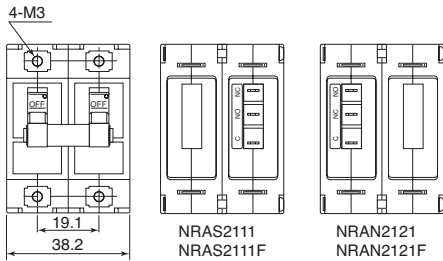

• 3-pole Type

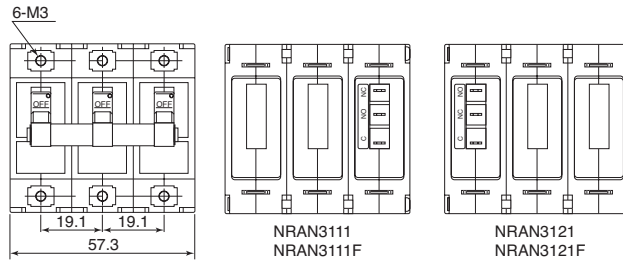

NRAR (Rocker Type)

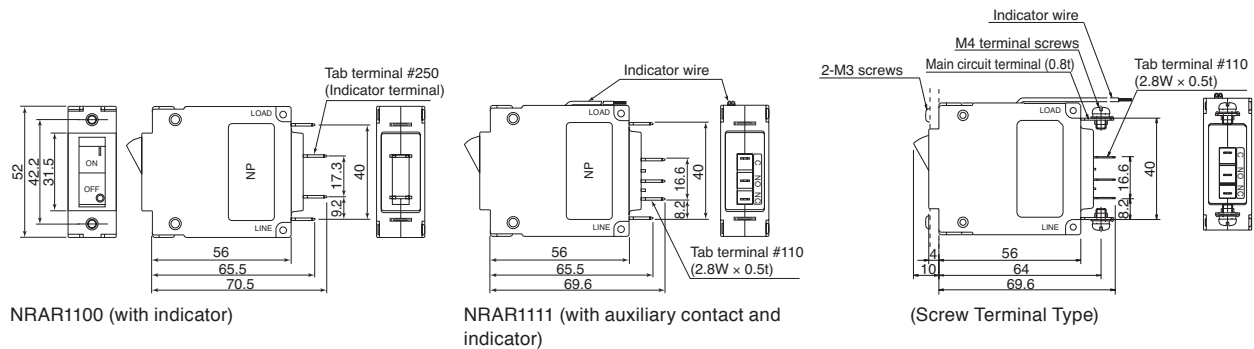

All dimensions in mm.

Mounting Hole Layout

Type	NRAS	NRAS with Flush Plate	NRAN and NRAR
Panel Cut-out	<p>Note: See "Accessories" for the mounting hole when the plug-in base is used.</p>	<p>Note: Flush plate is installed on the circuit protector before shipment and cannot be removed.</p>	<p>Note: "Accessories" for the mounting holes when the flush plate or plug-in base is used.</p>
	<p>M3 screw mounting Tightening torque: 0.5 N·m Tightening strength: 1.1 N·m</p>		

Panel Mounting Screw Length

Select the screw length with reference to the following table.

Panel thickness (mm)	0.8	1.0	1.2	1.4	1.6	1.8	2.0	2.3	2.6	3.2
Without washer	(4)	(4)	5	5	5	5	5	6	6	6
With plain washer (0.5 mm thick)	5	5	5	5	6	6	6	6	6	(7)
With spring washer (0.7 mm thick)	5	5	5	5	6	6	6	6	6	7
With plain washer (0.5 mm thick) and spring washer (0.7 mm thick)	6	6	6	6	6	6	6	(7)	(7)	8

Note: Avoid using screws in the parenthesized lengths whenever possible.

Installation Angle

Overcurrent tripping method is hydraulic magnetic. Minimum operating current varies with installation angle because operating currents are influenced by the weight of movable iron core. With reference to the following figure, correct the minimum operating current.

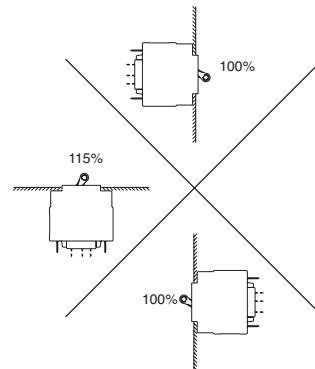

Instructions

One-pole type circuit protectors cannot be combined to make 2- or 3-pole units due to their characteristics. Order multi-pole types from IDEC.

Recommended Soldering Conditions

Solder the main terminal at a temperature of 390°C within 10 seconds using a 60W soldering iron.

Solder the auxiliary/alarm terminal at a temperature of 350°C within 3 seconds using a 60W soldering iron. (Sn-Ag-Cu lead-free solder is recommended.)

When soldering, do not touch the circuit protector housing, auxiliary and alarm contacts with the soldering iron, and do not bend the terminals or pull the wires.

Check your actual soldering conditions before soldering.

Main Circuit Terminal: Screw terminal



1. Applicable wire size	1.25 to 5.5 mm ²
2. Applicable crimping terminal	R1.25-4 to R5.5-4
3. No. of crimping terminal	1
4. Tightening torque	1.0 to 1.2 N·m
5. Tensile strength (Static 1 minute)	Axial direction: 80N Transverse direction: 20N

Thrust force (screw pressing load) in screw tightening should be 29N or less. The screw driver may slip out depending on the shape type and conditions. In this case, hold the terminal with a tool and tighten the screw by applying a thrust force of about 50N without deforming the terminal.

NRA Series Circuit Protectors

Accessories (Option)

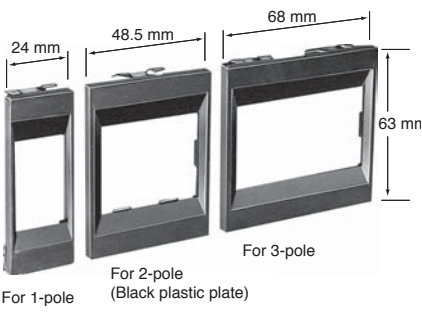
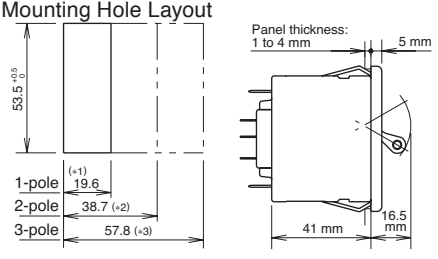
Package Quantity: 1

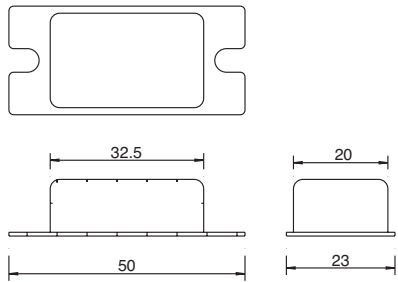
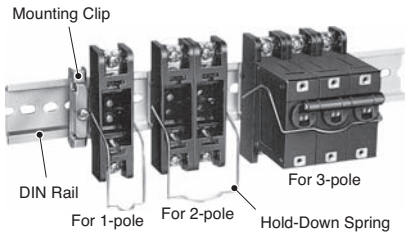
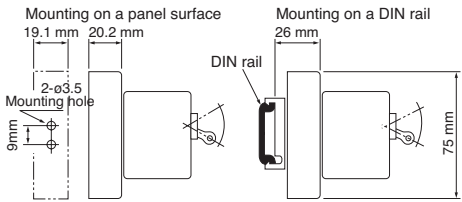
Appearance	Specifications	Type No.	For Use on	Description / Dimensions	
Flush Plate  <p>For 1-pole For 2-pole (Black plastic plate) For 3-pole</p>	For 1-pole	NR31	NRAN NRAR	Mounting Hole Layout  <p>Panel cut-out dimensions for collective mounting of two or more units are as follows: (N= No. of units) 1) 1-pole type --- 24.3N - 5 2) 2-pole type --- 48.8N - 10 3) 3-pole type --- 69.3N - 10</p>	
	For 2-pole	NR32	NRAN		
	For 3-pole	NR33			
Dustproof Cover  <p>(Silicon rubber)</p>	For 1-pole	NRA-C1	NRAR		
Plug-in Base (250V AC/DC • 20A max.) 	Surface Mount	For 1-pole	NUS1	NRAS NRAN	Surface mount types can mount directly on a panel surface with two M3 screws. DIN rail mount types can snap onto a DIN rail. Applicable only for series trip units. (Not applicable for units with auxiliary and alarm contact or with indicator.) Terminal screw M4, 20A max., with hold-down spring Tightening torque: 1.0 to 1.3 N•m
		For 2-pole	NUS2		
		For 3-pole	NUS3		
	DIN Rail Mount	For 1-pole	NUS11	NRAR	
		For 2-pole	NR21	NRAS NRAN	
			NR22		
			NR23		
		For 1-pole	NR211	NRAR	
					

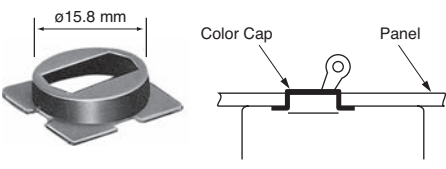
Appearance	Color	Type No.	Ordering Type No.	Package Quantity	For Use on	Description
Color Cap 	Blue	NR5S	NR5SPN05	5	NRAS	Color caps fit onto NRAS circuit protectors for color-coding circuits and improved appearance of the panel. Available in four colors: Blue (7.5B4/8 approx.) Red (7.5R5/14 approx.) White (N9.5 approx.) Yellow (2.5Y9/4 approx.)
	Red	NR5R	NR5RPN05			
	White	NR5H	NR5HPN05			
	Yellow	NR5Y	NR5YPN05			

NRL Series Circuit Protectors

Miniature circuit protectors with hydraulic-magnetic tripping system, allow for space and cost savings. Long life also reduces maintenance costs.

- Compact size (only 36.6H × 16.8W × 42D mm)
- One-lever (one-rocker) for 2-poles, ensures proper interruption to both poles when one pole is tripped.
- Low, middle, and high speed response
- Variety of rated currents and internal circuits
- Available with auxiliary contacts and inertia delay
- Over 20,000 mechanical operations
- Hydraulic-magnetic tripping system
- Safe trip-free mechanism
- Vibration-proof design

This product is recognized by Underwriters Laboratories under UL1077 as a "Supplementary Protector."

Applicable Standards	Certification Mark	Certification Organization / File No.
UL1077		UL/c-UL File No. E68029
CSA C22.2 No. 235		No. LR83454
EN60934 (VDE0642)		No. 102746
GB17701		CCC No. 2005010307151789
Electrical Appliance and Material Safety Law Technical Standard	 (For switch type)	(Electrical appliance excepting specified appliances)

For details, see the list of standard certified products in the back of this catalog.

Specifications

Type	NRLT	NRLP	NRLY	NRLR	NRLK
Appearance	 Lever Type (Lever color: Black)	 Lever Type (Lever color: Black)	 Rocker Type	 Illuminated Rocker Type (Neon, LED)	 Large Rocker Type
Operator Style	Lever	Lever	Rocker (non-illuminated), illuminated rocker		Large rocker (non-illuminated)
Protection Method	Hydraulic-magnetic tripping system				
Internal Circuit	Series trip (Current trip), Relay trip (Voltage trip)* Series trip (Current trip) with auxiliary contacts, Switch only, Switch only with auxiliary contact				*: Not available on NRLP
No. of Poles	1-pole, 2-pole (1-lever)	1-pole	1-pole, 2-pole (1-rocker)		
Rated Voltage	250V AC 50/60Hz, 50V DC				
Minimum Applicable Load	24V AC/DC, 100 mA (reference value)				
Rated Current	Current trip: 0.1A, 0.5A, 1A, 2A, 3A, 4A, 5A, 7.5A, 10A, 12.5A, 15A, 20A				Switch only type: 20A max.
Trip Voltage (Voltage trip)	100V AC 50/60Hz, 24V DC (operating at 90% of the rated voltage or higher, at 25°C) Voltage application duration: 1 sec maximum Trip time: 0.05 sec maximum (at the rated voltage)				
Rated Interrupting Capacity	250V AC 50/60Hz, 750A PC1 (UL rating: 1000A) 50V DC, 500A PC1 (UL rating: 1000A)				
Auxiliary Contact	SPDT microswitch 125V AC · 3A (resistive load), 30V DC · 2A (resistive load)				
Reference Temperature	+25°C				
Operating Temperature	-40 to +60°C (no freezing)				
Operating Humidity	45 to 85% RH (no condensation)				
Insulation Resistance	100 MΩ minimum (500V DC megger)				
Dielectric Strength	2000V AC, 1 minute (between live part and ground, between terminals of different poles, between terminals of the same pole when main contacts are open, between main circuit and auxiliary contact)				
Vibration Resistance	100 m/s ² (10 to 55 Hz), with the rated current applied				
Shock Resistance	500 m/s ² (operating extremes and damage limits), with the rated current applied (auxiliary contact: 360 m/s ²)				
Life	Electrical: Over 10,000 operations minimum (6 operations/min) Mechanical: Over 20,000 operations minimum (6 operations/min)				
Terminal Style (Note)	Main terminal: Tab terminal #250 [NRLP: PCB terminal] Auxiliary contact terminal: Solder terminal [NRLP: PCB terminal] Indicator terminal [Illuminated rocker type]: Tab terminal #110				
Mounting Style	Ring mounting	PC board mounting	Snap-on mounting	Screw mounting	Screw mounting
Weight (Approx.)	1-pole: 30g 2-pole: 60g (NRLT series trip)				

- The ratings of switch only type are 250V AC/50V DC and 20A, without protection function.
- Note: Indicator terminal of 1-pole illuminated rocker type with auxiliary contact is a lead wire.

• Indicator Ratings (Illuminated Rocker Type)

Indicator	Voltage
Neon	100 to 125V AC
LED	6V, 12V, 24V, 48V AC/DC ±10%





Note: Both neon and LED indicators have a built-in current limiting resistors.

• Standard Color

Housing	Black		
Lever (NRLT and NRLP)	Black		
Rocker and Indicator	Rocker Color	Indicator Color	
(NRLY) (NRLR)	Non-illuminated	Black, red, green	
	Neon	Transparent red	Red
	LED	Transparent red	Red
Large Rocker (NRLK)	Black, Red		

NRL Series Circuit Protectors

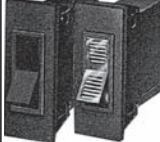
Type No. Development

1 Type					8 Rocker Color (Non-illuminated rocker only)		
Lever Type NRLT	Lever Type NRLP	Rocker Type NRLY	Rocker Type NRLR	Large Rocker Type NRLK	NRLY, NRLR rocker type (non-illuminated) and NRLK large rocker type only		
					Black	(Code) B	
					Green	G	
					Red	R	
					8 Indicator Operating Voltage		
					NRLY and NRLR illuminated rocker type only		
					Light Source	Rated Voltage	(Code)
					Neon	125V AC 50/60Hz	1
					LED	6V AC/DC	3
						12V AC/DC	4
						24V AC/DC	5
						48V AC/DC	7

1	2	3	4	5	6	7	8
NRLT	1	1	11	F	3A	AD	

2 No. of Poles		3 Internal Circuit		4 Auxiliary Contacts		5 Inertia Delay		6 Rated Current and Voltage		7 Time Delay Curves		
1-pole	(Code) 1	Series Trip (Current Trip)	1	Without	(Code) 00	Without	(Code) Blank	• Current Trip		AC	AA	
2-pole	2	Relay Trip* (Voltage Trip)	5	w/auxiliary contacts	Solder Terminal	11	With*	F	0.1A		5A	BA
NRLP is available only in 1-pole type.		Switch Only Type	0		PCB Terminal	14		*Inertia delay is not available on curves EA and ED.		1A	10A	EA
		*NRLP is available only in series trip and switch only type.		On the 2-pole type, one auxiliary contact is provided on the left side as viewed from the front.				Rated Voltage		2A	12.5A	AD
								100V AC		3A	15A	BD
								24V DC		4A	20A	ED
										*Inertia delay is not available on curves EA and ED.		
										*Switch only type does not require designation.		

NRLT (Lever Type)

• Specify a rated current or voltage, and time delay curve in place of 6 7.

Package Quantity: 1

Internal Circuit	No. of Poles	Inertia Delay	Auxiliary Contact	Type No. (Ordering Type No.)	Designation Code			
					6 Rated Current or Voltage	7 Time Delay Curve		
Series Trip Current Trip	1	Without	Without	NRLT1100- 6 7	0.1A, 0.5A, 1A, 2A, 3A, 4A, 5A, 7.5A, 10A, 12.5A, 15A, 20A	AA, AD, BA, BD, EA, ED		
			With	NRLT1111- 6 7				
		With	Without	NRLT1100F- 6 7				
			With	NRLT1111F- 6 7				
	2	Without	Without	NRLT2100- 6 7			AA, AD, BA, BD	
			With	NRLT2111- 6 7			AA, AD, BA, BD, EA, ED	
Relay Trip Voltage Trip	1	Without	Without	NRLT1500- 6	100V AC 24V DC	—		
			2	Without			NRLT2500- 6	
	2		Without	Without			NRLT1000	—
				With			NRLT1011	
Switch Only Type	1	Without	Without	NRLT2000	—	—		
			With	NRLT2011				
2	Without		Without	NRLT2000				
			With	NRLT2011				

NRLY (Rocker Type)	[Snap-on Mounting Type]
---------------------------	--------------------------------

• Specify a rated current or voltage, time delay curve, and indicator or rocker color in place of [6] [7] [8]. Package Quantity: 1

Illumination	Internal Circuit	No. of Poles	Inertia Delay	Auxiliary Contact	Type No. (Ordering Type No.)	Designation Code				
						[6] Rated Current and Voltage	[7] Time Delay Curve	[8] Indicator	[8] Rocker Color	
Illuminated Type	Series Trip Current Trip	1	Without	Without	NRLY1100-[6][7]-[8]	0.1A 0.5A 1A 2A 3A 4A 5A 7.5A 10A 12.5A 15A 20A	AA, AD, BA, BD, EA, ED	1: Neon 125V AC 50/60Hz 3: LED 6V AC/DC 4: LED 12V AC/DC 5: LED 24V AC/DC 7: LED 48V AC/DC	—	
				With	NRLY1111-[6][7]-[8]					
			With	Without	NRLY1100F-[6][7]-[8]					AA, AD, BA, BD
				With	NRLY1111F-[6][7]-[8]					
		2	Without	Without	NRLY2100-[6][7]-[8]		100V AC 24V DC			—
				With	NRLY2111-[6][7]-[8]					
			With	Without	NRLY2100F-[6][7]-[8]					
				With	NRLY2111F-[6][7]-[8]					
	Relay Trip Voltage Trip	1	Without	Without	NRLY1500-[6]-[8]	100V AC 24V DC	—			
				Without	NRLY2500-[6]-[8]					
		2	Without	Without	NRLY1000-[8]			—	—	
				With	NRLY1011-[8]					
				Without	NRLY2000-[8]					
				With	NRLY2011-[8]					
Non-illuminated Type	Series Trip Current Trip	1	Without	Without	NRLY1100-[6][7]-[8]	0.1A 0.5A 1A 2A 3A 4A 5A 7.5A 10A 12.5A 15A 20A	AA, AD, BA, BD, EA, ED	—	B, G, R	
				With	NRLY1111-[6][7]-[8]					
			With	Without	NRLY1100F-[6][7]-[8]					AA, AD, BA, BD
				With	NRLY1111F-[6][7]-[8]					
		2	Without	Without	NRLY2100-[6][7]-[8]		100V AC 24V DC			—
				With	NRLY2111-[6][7]-[8]					
			With	Without	NRLY2100F-[6][7]-[8]					
				With	NRLY2111F-[6][7]-[8]					
	Relay Trip Voltage Trip	1	Without	Without	NRLY1500-[6]-[8]	100V AC 24V DC	—			
				Without	NRLY2500-[6]-[8]					
		2	Without	Without	NRLY1000-[8]			—	—	
				With	NRLY1011-[8]					
				Without	NRLY2000-[8]					
				With	NRLY2011-[8]					

Flush Silhouette
Control Units
Display Lights
Display Units
Safety Products
Terminal Blocks
Comm Terminals
AS-Interface
Relays & Timers
Sockets
Circuit Protectors
Power Supplies
PLCs & SmartRelay
Operator Interfaces
Sensors
Control Stations
Explosion Protection
References

NRL Series Circuit Protectors

NRLR (Rocker Type)

[Screw Mounting Type]

• Specify a rated current or voltage, time delay curve, and indicator or rocker color in place of [6] [7] [8]. Package Quantity: 1

Illumination	Internal Circuit	No. of Poles	Inertia Delay	Auxiliary Contact	Type No. (Ordering Type No.)	Designation Code				
						[6] Rated Current and Voltage	[7] Time Delay Curve	[8] Indicator	[8] Rocker Color	
Illuminated Type	Series Trip Current Trip	1	Without	Without	NRLR1100- [6] [7] - [8]	0.1A 0.5A 1A 2A 3A 4A 5A 7.5A 10A 12.5A 15A 20A	AA, AD, BA, BD, EA, ED	1: Neon 125V AC 50/60Hz 3: LED 6V AC/DC 4: LED 12V AC/DC 5: LED 24V AC/DC 7: LED 48V AC/DC	—	
				With	NRLR1111- [6] [7] - [8]					
			With	Without	NRLR1100F- [6] [7] - [8]		AA, AD, BA, BD			
				With	NRLR1111F- [6] [7] - [8]					
		2	Without	Without	NRLR2100- [6] [7] - [8]		100V AC 24V DC			AA, AD, BA, BD, EA, ED
				With	NRLR2111- [6] [7] - [8]					
			With	Without	NRLR2100F- [6] [7] - [8]					AA, AD, BA, BD
				With	NRLR2111F- [6] [7] - [8]					
	Relay Trip Voltage Trip	1	Without	Without	NRLR1500- [6] - [8]	100V AC 24V DC	—			
		2		Without	NRLR2500- [6] - [8]					
	Switch Only Type	1	Without	Without	NRLR1000- [8]	—	—			
				With	NRLR1011- [8]					
		2		Without	NRLR2000- [8]					
				With	NRLR2011- [8]					
	Non-illuminated Type	Series Trip Current Trip	1	Without	Without	NRLR1100- [6] [7] - [8]	0.1A 0.5A 1A 2A 3A 4A 5A 7.5A 10A 12.5A 15A 20A	AA, AD, BA, BD, EA, ED	—	B, G, R
					With	NRLR1111- [6] [7] - [8]				
With				Without	NRLR1100F- [6] [7] - [8]	AA, AD, BA, BD				
				With	NRLR1111F- [6] [7] - [8]					
2			Without	Without	NRLR2100- [6] [7] - [8]	100V AC 24V DC		AA, AD, BA, BD, EA, ED		
				With	NRLR2111- [6] [7] - [8]					
			With	Without	NRLR2100F- [6] [7] - [8]			AA, AD, BA, BD		
				With	NRLR2111F- [6] [7] - [8]					
Relay Trip Voltage Trip		1	Without	Without	NRLR1500- [6] - [8]	100V AC 24V DC	—			
		2		Without	NRLR2500- [6] - [8]					
Switch Only Type		1	Without	Without	NRLR1000- [8]	—	—			
				With	NRLR1011- [8]					
		2		Without	NRLR2000- [8]					
				With	NRLR2011- [8]					

NRL Series Circuit Protectors

NRLK (Large Rocker Type) [Snap-on Mounting Type]

• Specify a rated current or voltage, time delay curve, and rocker color in place of [6] [7] [8]. Package Quantity: 1

Internal Circuit	No. of Poles	Inertia Delay	Auxiliary Contact	Type No. (Ordering Type No.)	Designation Code		
					[6] Rated Current and Voltage	[7] Time Delay Curve	[8] Rocker Color
Series Trip Current Trip	1	Without	Without	NRLK1100- [6] [7] - [8]	0.1A 0.5A 1A 2A 3A 4A 5A 7.5A 10A 12.5A 15A 20A	AA, AD, BA, BD, EA, ED	B, G, R
			With	NRLK1111- [6] [7] - [8]			
		With	Without	NRLK1100F- [6] [7] - [8]			
			With	NRLK1111F- [6] [7] - [8]			
	2	Without	Without	NRLK2100- [6] [7] - [8]			
			With	NRLK2111- [6] [7] - [8]			
		With	Without	NRLK2100F- [6] [7] - [8]			
			With	NRLK2111F- [6] [7] - [8]			
Relay Trip Voltage Trip	1	Without	Without	NRLK1500- [6] - [8]	100V AC 24V DC	—	
	2		Without	NRLK2500- [6] - [8]		—	
Switch Only Type	1	Without	Without	NRLK1000- [8]	—	—	
			With	NRLK1011- [8]			
	2		Without	NRLK2000- [8]			
			With	NRLK2011- [8]			

NRLP (Lever Type) [PC Board Mounting Type]

• Specify a rated current and time delay curve in place of [6] [7]. Package Quantity: 1

Internal Circuit	No. of Poles	Inertia Delay	Auxiliary Contact	Type No. (Ordering Type No.)	Designation Code	
					[6] Rated Current	[7] Time Delay Curve
Series Trip Current Trip	1	Without	Without	NRLP1100- [6] [7]	0.1A 0.5A 1A 2A 3A 4A 5A 7.5A 10A 12.5A 15A 20A	AA, AD, BA, BD, EA, ED
			With	NRLP1114- [6] [7]		
		With	Without	NRLP1100F- [6] [7]		AA, AD, BA, BD
			With	NRLP1114F- [6] [7]		
Switch Only Type	1	Without	Without	NRLP1000	—	—
			With	NRLP1014		

- Flush Silhouette
- Control Units
- Display Lights
- Display Units
- Safety Products
- Terminal Blocks
- Comm Terminals
- AS-Interface
- Relays & Timers
- Sockets
- Circuit Protectors
- Power Supplies
- PLCs & SmartRelay
- Operator Interfaces
- Sensors
- Control Stations
- Explosion Protection
- References

NRL Series Circuit Protectors

Internal Circuits

NRLT, NRLP, NRLY (Non-illuminated), NRLR (Non-illuminated), and NRLK

Series Trip (Current Trip)	Series Trip (Current Trip)	Relay Trip (Voltage Trip)	Switch Only Type	Switch Only Type With Auxiliary Contact

NRLY (Illuminated Type), NRLR (Illuminated Type)

Series Trip (Current Trip)	Series Trip (Current Trip)	Relay Trip (Voltage Trip)	Switch Only Type	Switch Only Type With Auxiliary Contact

On the 2-pole type, indicator terminal are a tab terminals.

Note 1: On the 2-pole type, one auxiliary contact is provided on the left side as viewed from the front.
See the dimensional drawing for the terminal arrangement.

Note 2: NRLP is available with series trip and switch type.

- Wiring Example

Lead wire	Color	Neon Indicator	LED Indicator
(Lead wire A)	Red	AC	Positive
(Lead wire B)	Black	AC	Negative

Overcurrent - Time Delay Characteristics (sec at 25°C)

Time Delay Curves		Percent of Rated Current						
AC 50/60Hz	DC	100%	135%	150%	200%	400%	600%	800%
AA ★	AD ★	No Trip	3-70	2-40	1-15	0.1-4	0.01-2	0.007-0.8
BA ★	BD ★	No Trip	0.3-7	0.2-5	0.1-2	0.03-0.5	0.01-0.3	0.007-0.15
EA	ED	No Trip	0.015-0.5	0.01-0.25	0.009-0.1	0.006-0.03	0.005-0.02	0.004-0.02

Note: Curves marked with ★ are also available with inertia delay. (Inertia delay is not available for Curves ED and EA)

Time Delay Curves

Note: Curves marked with ★ are also available with inertia delay.

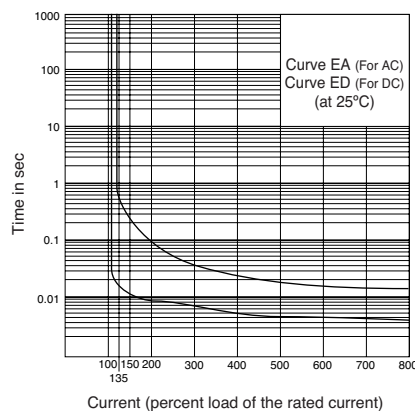
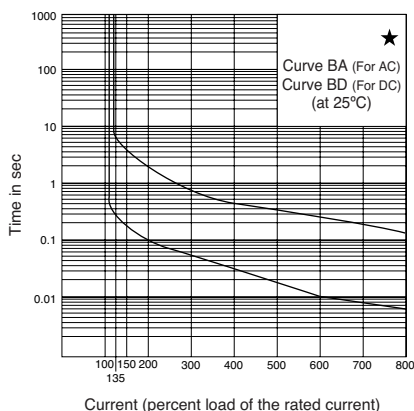
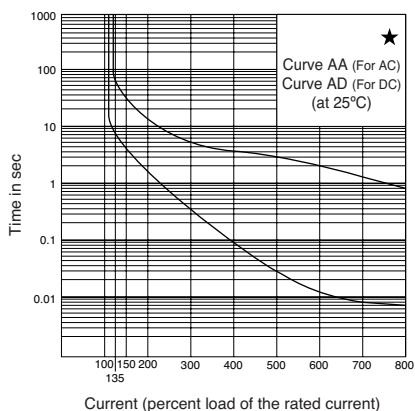

Circuit Protector with Inertia Delay

Inertia delay is designed not to trip on a non-repeating single pulse of 12 times the rated current (peak value) for duration of 8 ms. In addition, circuit protectors equipped with inertia delay do not respond to high inrush currents caused by transformer or lamp loads, but perform the specified interruption on the subsequent overcurrents. Curves EA and ED are not available with inertia delay.

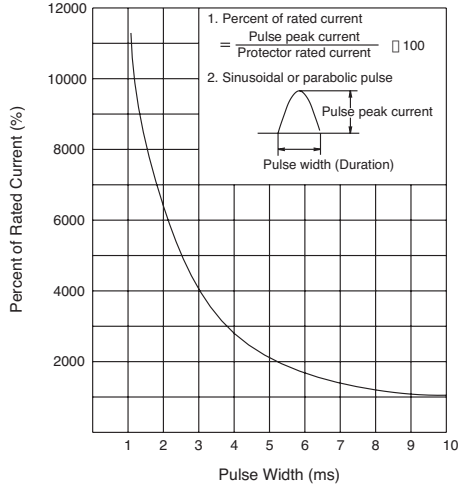

Temperature Correction Curve

The time delay curves on the preceding page are at 25°C. With reference to the following curves, time delays can be corrected according to the ambient temperature.

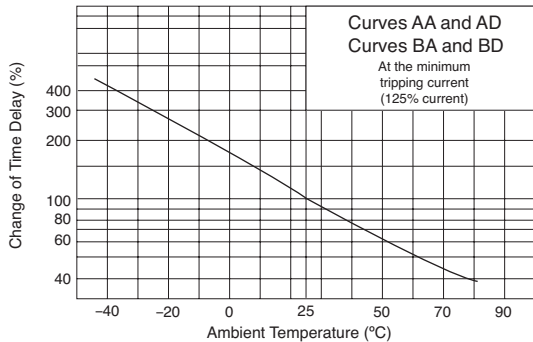

Operation of Auxiliary Contacts

At tripping or manual ON-OFF operation, there is a lag in time between the operation of the main contact and the auxiliary contact.

Impedance and Coil Resistance (at 25°C)

Rated Current	For AC 50/60Hz Impedance (Ω)	For DC, Impedance between Terminals (Ω)
	Curves AA, BA, and EA	Curves AD, BD, and ED
0.1A	97.0	96.0
0.5A	3.2	3.1
1A	0.81	0.78
2A	0.19	0.18
3A	0.086	0.085
4A	0.051	0.050
5A	0.034	0.034
7.5A	0.017	0.016
10A	0.0092	0.0087
12.5A	0.0068	0.0065
15A	0.0052	0.0050
20A	0.0033	0.0031

Note: Tolerance: ±25% (up to 5A), ±50% (7.5A or higher)

[Voltage trip type]

	For AC 50/60Hz Impedance (Ω)	For DC, Impedance between Terminals (Ω)
100V AC	3000	—
24V DC	—	370

Note: Tolerance: ±25%

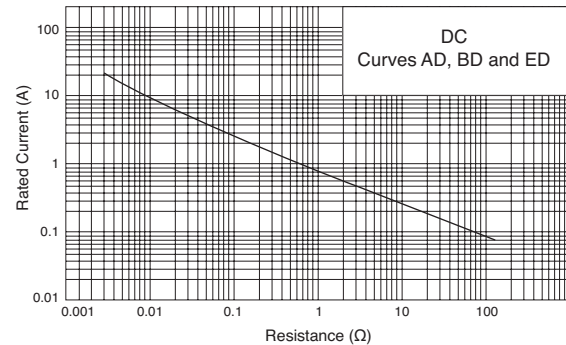
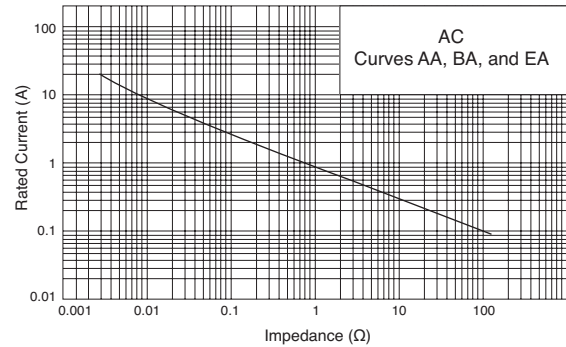

Rated Current (Trip Current) by Installation Angle

Overcurrent tripping method is hydraulic magnetic. Minimum operating currents vary with installation angle because operating currents are influenced by the weight of the iron core. With reference to the following figure, correct the rated current.

Note 1: The rated current does not change depending on the installation angle.

Note 2: The minimum operating current is calculated from the following formula:

$$(\text{Minimum operating current}) = (\text{Rated current}) \times 135\% \times (\text{Correction factor by installation angle})$$

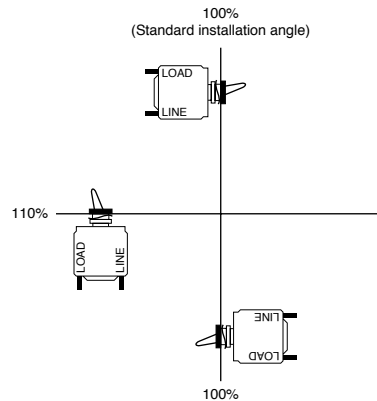

- Flush Silhouette
- Control Units
- Display Lights
- Display Units
- Safety Products
- Terminal Blocks
- Comm Terminals
- AS-Interface
- Relays & Timers
- Sockets
- Circuit Protectors
- Power Supplies
- PLCs & SmartRelay
- Operator Interfaces
- Sensors
- Control Stations
- Explosion Protection
- References

NRL Series Circuit Protectors

Dimensions

• **NRLT (Lever Type)** Note: The dashed lines show the 2-pole type.

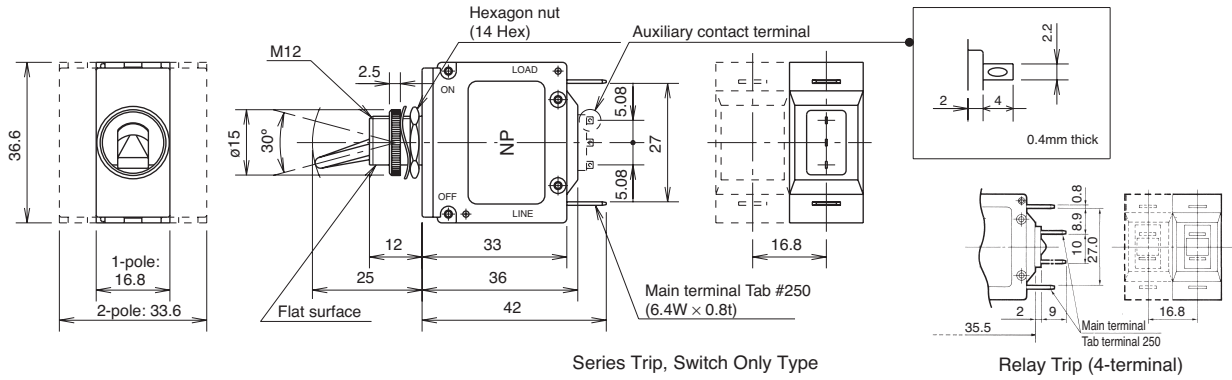

• **NRLP (Lever Type with PCB terminals)**

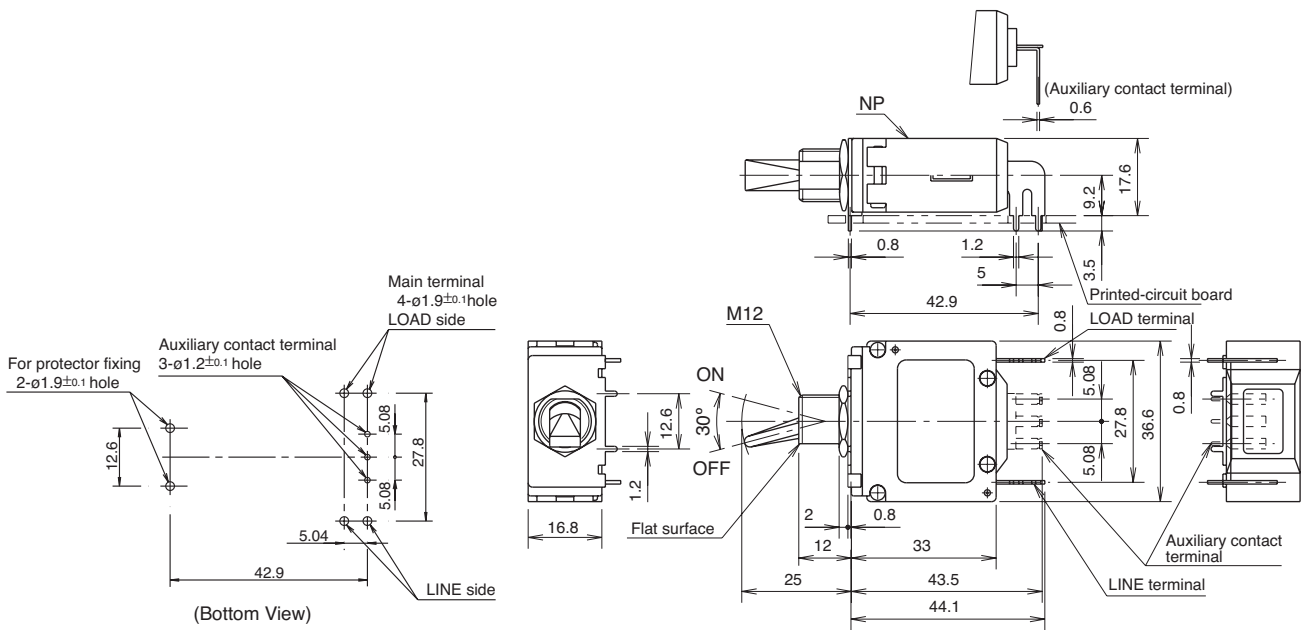

All dimensions in mm.

• **NRLY (Snap-on Mounting, Rocker Type)** Note: The dashed lines show the 2-pole type.

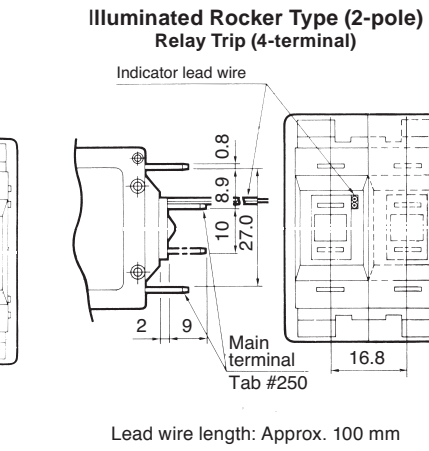
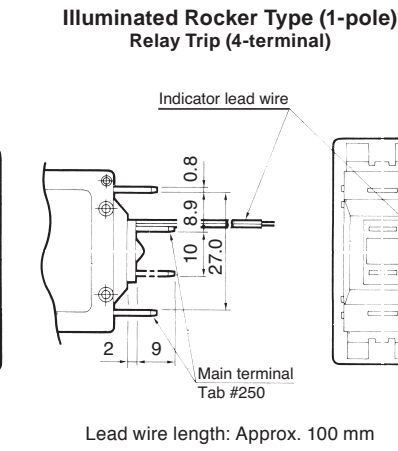
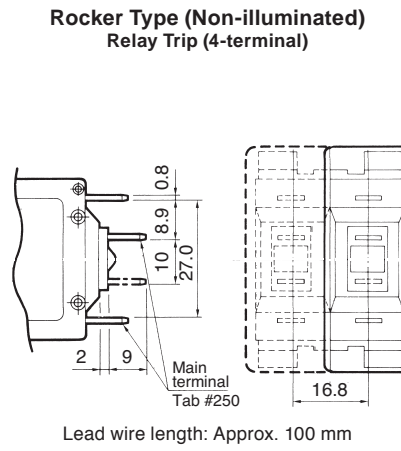
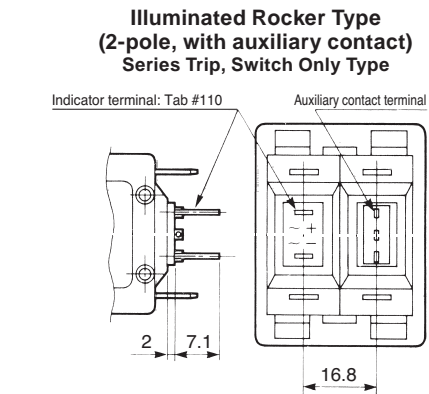
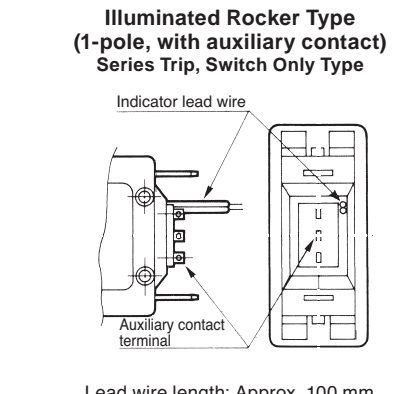
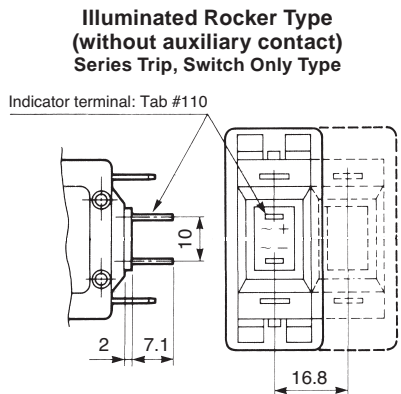
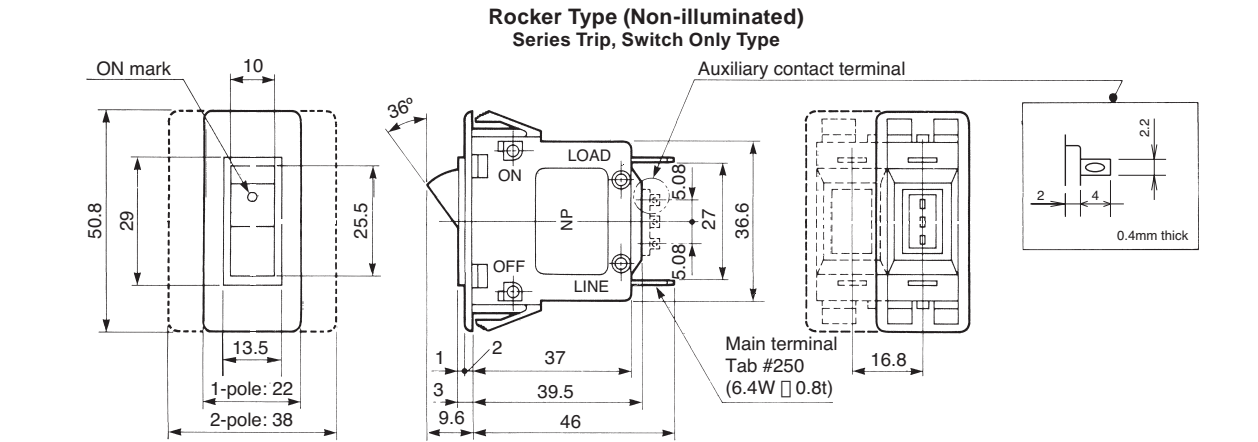

• **NRLK (Large Rocker Type)** Note: The dashed lines show the 2-pole type.

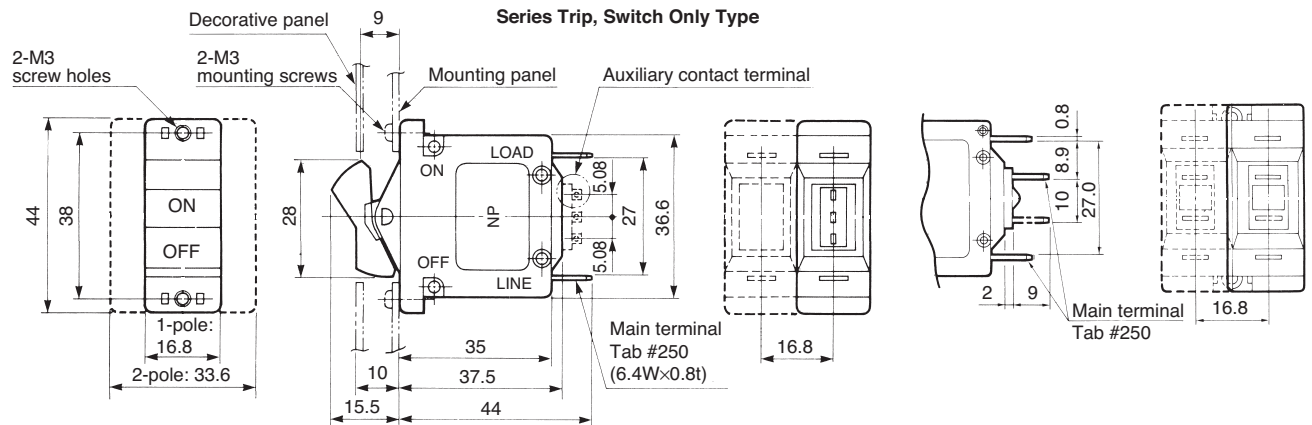

Flush Silhouette
Control Units
Display Lights
Display Units
Safety Products
Terminal Blocks
Comm Terminals
AS-Interface
Relays & Timers
Sockets
Circuit Protectors
Power Supplies
PLCs & SmartRelay
Operator Interfaces
Sensors
Control Stations
Explosion Protection
References

NRL Series Circuit Protectors

•NRLR (Screw Mounting, Rocker Type) Note: The dashed lines show the 2-pole type.

Rocker Type (Non-illuminated) Series Trip, Switch Only Type

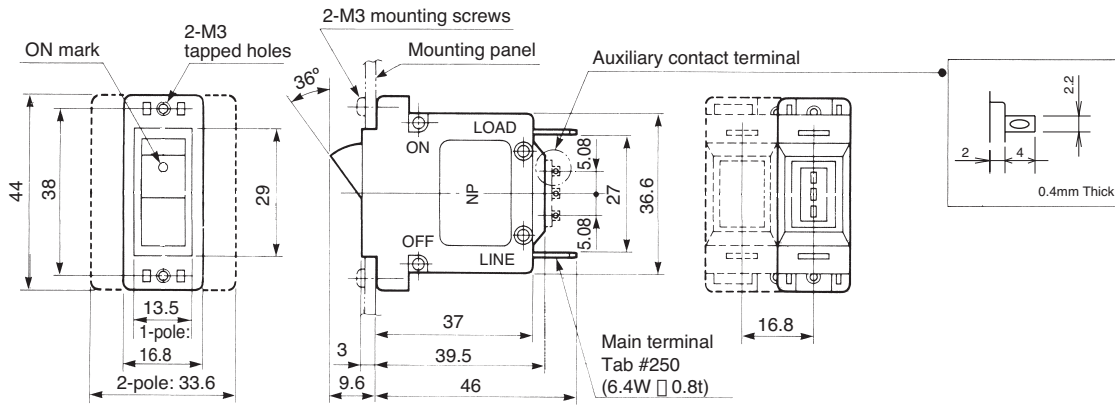

Illuminated Rocker Type (without auxiliary contact) Series Trip, Switch Only Type

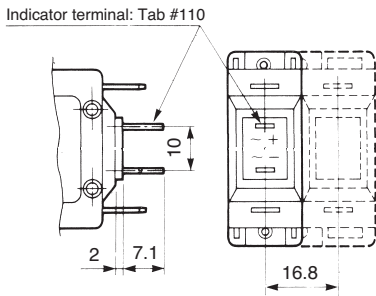

Illuminated Rocker Type (1-pole, with auxiliary contact) Series Trip, Switch Only Type

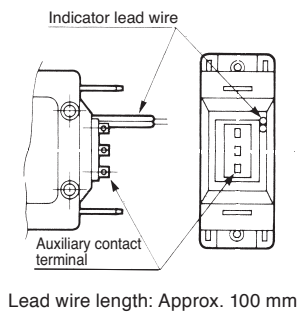

Illuminated Rocker Type (2-pole, with auxiliary contact) Series Trip, Switch Only Type

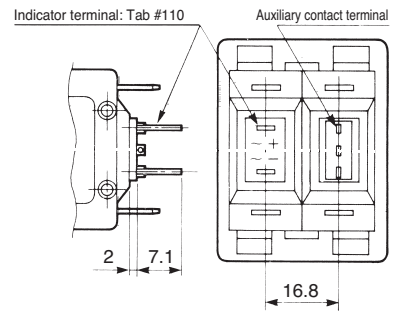

Rocker Type (Non-illuminated) Relay Trip (4-terminal)

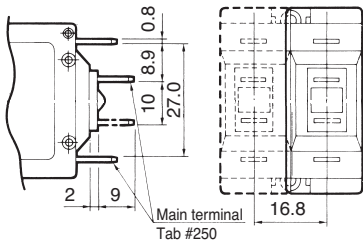

Illuminated Rocker Type (1-pole) Relay Trip (4-terminal)

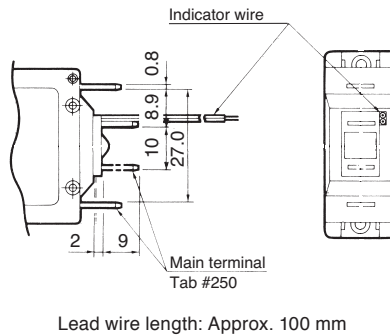

Illuminated Rocker Type (2-pole) Relay Trip (4-terminal)

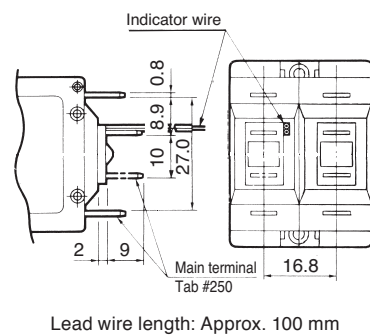







Mounting Hole Layout

Type	NRLT (Lever Type)	NRLY (Snap-on Mounting, Rocker Type)																																																					
Panel Cut-out	<p>When anti-rotation ring is used. (Type No.: NRL-L)</p> <p>1-pole/2-pole</p> <p>1-pole/2-pole</p> <p>Tightening torque: 1.2 to 1.4 N·m</p>	<p>1-pole Type</p> <p>2-pole Type</p>																																																					
Panel Thickness	<p>Maximum mounting panel thickness (NRLT):</p> <table border="1" style="width: 100%; border-collapse: collapse;"> <thead> <tr> <th>Mounting Nut</th> <th>Name Plate</th> <th>Anti-rotation Ring</th> <th>Maximum Panel Thickness</th> </tr> </thead> <tbody> <tr> <td></td> <td></td> <td></td> <td>NRLT</td> </tr> <tr> <td rowspan="3">When a standard bezel is used (Thickness: 2.5 mm)</td> <td>—</td> <td>—</td> <td>5.5 mm</td> </tr> <tr> <td>X</td> <td>—</td> <td>4.7 mm</td> </tr> <tr> <td>—</td> <td>X</td> <td>4.7 mm</td> </tr> <tr> <td rowspan="3">When a decorative bezel is used (Thickness: 4 mm)</td> <td>X</td> <td>X</td> <td>3.9 mm</td> </tr> <tr> <td>—</td> <td>—</td> <td>4.0 mm</td> </tr> <tr> <td>X</td> <td>—</td> <td>3.2 mm</td> </tr> <tr> <td></td> <td>—</td> <td>X</td> <td>3.2 mm</td> </tr> <tr> <td></td> <td>X</td> <td>X</td> <td>2.4 mm</td> </tr> </tbody> </table> <p>Note 1: Standard mounting nut is supplied with the protector. Note 2: Decorative bezel, name plate, and anti-rotation ring are sold separately. (See "Accessories" for details.)</p>	Mounting Nut	Name Plate	Anti-rotation Ring	Maximum Panel Thickness				NRLT	When a standard bezel is used (Thickness: 2.5 mm)	—	—	5.5 mm	X	—	4.7 mm	—	X	4.7 mm	When a decorative bezel is used (Thickness: 4 mm)	X	X	3.9 mm	—	—	4.0 mm	X	—	3.2 mm		—	X	3.2 mm		X	X	2.4 mm	<p>Panel thickness and Dimension A</p> <table border="1" style="width: 100%; border-collapse: collapse;"> <thead> <tr> <th>Panel Thickness</th> <th>0.8 to 1.2 mm</th> <th>1.6 mm</th> <th>2.3 mm</th> <th>3.2 mm</th> </tr> </thead> <tbody> <tr> <td>Dimension A</td> <td>44.6 mm</td> <td>45.1 mm</td> <td>45.9 mm</td> <td>46.9 mm</td> </tr> </tbody> </table> <p style="text-align: center;">Tolerance ±0.1 mm</p> <p>Note 1: Allowable range of mounting panel thickness: 0.8 to 3.2 mm Note 2: Within the allowable range of mounting panel, Dimension A for panel thicknesses other than those listed in the above table can be calculated from the following formula: Dimension A = 45.1 + 1.1 × (Panel thickness - 1.6)</p>	Panel Thickness	0.8 to 1.2 mm	1.6 mm	2.3 mm	3.2 mm	Dimension A	44.6 mm	45.1 mm	45.9 mm	46.9 mm							
Mounting Nut	Name Plate	Anti-rotation Ring	Maximum Panel Thickness																																																				
			NRLT																																																				
When a standard bezel is used (Thickness: 2.5 mm)	—	—	5.5 mm																																																				
	X	—	4.7 mm																																																				
	—	X	4.7 mm																																																				
When a decorative bezel is used (Thickness: 4 mm)	X	X	3.9 mm																																																				
	—	—	4.0 mm																																																				
	X	—	3.2 mm																																																				
	—	X	3.2 mm																																																				
	X	X	2.4 mm																																																				
Panel Thickness	0.8 to 1.2 mm	1.6 mm	2.3 mm	3.2 mm																																																			
Dimension A	44.6 mm	45.1 mm	45.9 mm	46.9 mm																																																			
Type	NRLR (Screw Mounting, Rocker Type)	NRLK (Large Rocker Type)																																																					
Panel Cut-out	<p>1-pole/2-pole</p>	<p>1-pole/2-pole</p> <p>Panel cut-out of decorative panel Note: These dimensions are reference values. When considering the design, check the actual unit.</p>																																																					
Panel Thickness	3 mm maximum	See the dimensional drawing and select proper thickness, considering the height of mounting screw head.																																																					
Applicable Mounting Screw Length	<p>• Applicable length of panel mounting screw (M3) Select proper length according to the table.</p> <table border="1" style="width: 100%; border-collapse: collapse;"> <thead> <tr> <th>Panel thickness (mm)</th> <th>0.8</th> <th>1.0</th> <th>1.2</th> <th>1.4</th> <th>1.6</th> <th>1.8</th> <th>2.0</th> <th>2.3</th> <th>2.6</th> <th>3.2</th> </tr> </thead> <tbody> <tr> <td>Without washer</td> <td colspan="3">6 to 10 mm</td> <td colspan="3">7 to 11 mm</td> <td colspan="4">8 to 12 mm</td> </tr> <tr> <td>With plain washer (0.5 mm thick)</td> <td>6 to 10 mm</td> <td colspan="3">7 to 11 mm</td> <td colspan="3">8 to 12 mm</td> <td colspan="3">9 to 13 mm</td> </tr> <tr> <td>With spring washer (0.7 mm thick)</td> <td colspan="3">7 to 11 mm</td> <td colspan="3">8 to 12 mm</td> <td colspan="3">9 to 13 mm</td> </tr> <tr> <td>With plain washer (0.5 mm thick), and spring washer (0.7 mm thick)</td> <td colspan="2">7 to 11 mm</td> <td colspan="3">8 to 12 mm</td> <td colspan="4">9 to 13 mm</td> </tr> </tbody> </table> <p>(M3 screw tightening torque: 0.5 to 0.8 N·m)</p> <div style="text-align: right;"> <p>Screw Mounting Part Dimensions</p> </div>		Panel thickness (mm)	0.8	1.0	1.2	1.4	1.6	1.8	2.0	2.3	2.6	3.2	Without washer	6 to 10 mm			7 to 11 mm			8 to 12 mm				With plain washer (0.5 mm thick)	6 to 10 mm	7 to 11 mm			8 to 12 mm			9 to 13 mm			With spring washer (0.7 mm thick)	7 to 11 mm			8 to 12 mm			9 to 13 mm			With plain washer (0.5 mm thick), and spring washer (0.7 mm thick)	7 to 11 mm		8 to 12 mm			9 to 13 mm			
Panel thickness (mm)	0.8	1.0	1.2	1.4	1.6	1.8	2.0	2.3	2.6	3.2																																													
Without washer	6 to 10 mm			7 to 11 mm			8 to 12 mm																																																
With plain washer (0.5 mm thick)	6 to 10 mm	7 to 11 mm			8 to 12 mm			9 to 13 mm																																															
With spring washer (0.7 mm thick)	7 to 11 mm			8 to 12 mm			9 to 13 mm																																																
With plain washer (0.5 mm thick), and spring washer (0.7 mm thick)	7 to 11 mm		8 to 12 mm			9 to 13 mm																																																	

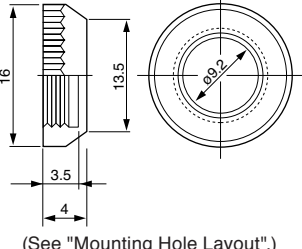
Flush Silhouette
Control Units
Display Lights
Display Units
Safety Products
Terminal Blocks
Comm Terminals
AS-Interface
Relays & Timers
Sockets
Circuit Protectors
Power Supplies
PLCs & SmartRelay
Operator Interfaces
Sensors
Control Stations
Explosion Protection
References

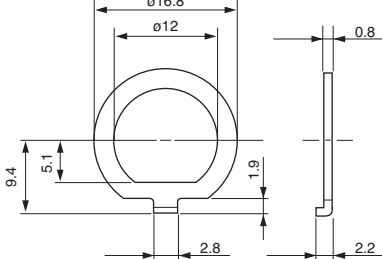
NRL Series Circuit Protectors

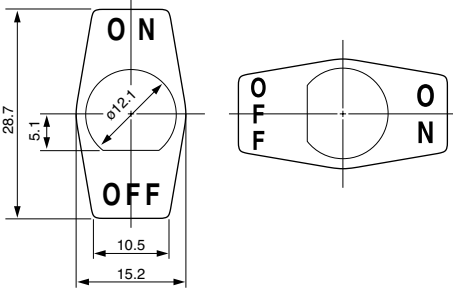
Accessories for NRLT (Lever Type) · Optional

Name and Appearance		Type No.	Ordering Type No.	Package Quantity	Description and Dimensions
• Decorative Bezel 		NRL-R	NRL-RPN05	5	<ul style="list-style-type: none"> The decorative bezel can be used in place of the standard bezel. Note that the maximum panel thickness differs from that with the standard bezel. Material: Chrome-plated metal  <p>(See "Mounting Hole Layout".)</p>
• Anti-rotation Ring 		NRL-L	NRL-LPN05	5	<ul style="list-style-type: none"> The anti-rotation ring is intended to ensure firm rotation prevention. (See "Mounting Hole Layout".) Metal ring 
• Nameplate 		(Legend)		5	<ul style="list-style-type: none"> Aluminum plate (Aluminum colored) with black legend 
	ON OFF	NRL-N1	NRL-N1PN05		
	I O	NRL-N3	NRL-N3PN05		
		OFF - ON F - N	NRL-N2		
	O - I	NRL-N4	NRL-N4PN05	5	

Package Quantity: 1

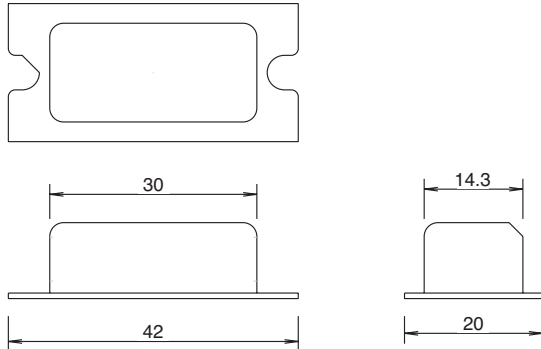
Name and Appearance		Type No.	Dimensions
• Dustproof Cover  (Silicon Rubber)		For 1-pole	• For NRLR 
		NRL-C	

NRBM Series Circuit Protectors

Variety of rated currents: 1A to 50A

Widely employed for protection of PC power circuits and large current circuits of welding machines.

NRBM is the largest in the rated current among the IDEC circuit protector series.

Electromagnetic trip, not affected by ambient temperature





Safe trip-free mechanism

Available with auxiliary contact and alarm contact

Available with inertia delay

Vibration-proof design

This product is recognized by Underwriters Laboratories under UL1077 as a "Supplementary Protector."

Applicable standards	Certification Mark	Certification Organization / File No.
UL1077 CSA C22.2 No. 235		UL/c-UL File No. E68029
EN60934 (VDE0642)		No. 113434
GB17701		CCC No. 2005010307151788
Electrical Appliance and Material Safety Law Technical Standard		JET

For details, see the list of standard certified products in the back of this catalog.



Specifications

Type	NRBM
Operator	Lever type
Protection Method	Hydraulic-magnetic tripping system
Internal Circuit	Series trip (current trip) Series trip with auxiliary contacts Series trip with alarm contacts
No. of poles	1, 2, 3 poles
Rated Voltage	250V AC 50/60 Hz, 65V DC
Minimum Applied Load	24V AC/DC, 100 mA (reference value)
Rated Current	Current trip: 1A, 2A, 3A, 5A, 7.5A, 10A, 15A, 20A, 25A, 30A, 40A, 50A
Rated Interrupting Capacity	250V AC 50/60Hz, 65V DC, 1000A
Auxiliary Contact	SPDT microswitch
Alarm Contact	250V AC 5A 50V DC 1A (resistive load)
Reference Temperature	+25°C
Operating Temperature	-40 to +85°C (no freezing)
Operating Humidity	45 to 85% RH (no condensing)
Insulation Resistance	100 MΩ minimum (500V DC megger)
Dielectric Strength	2000V AC for 1 minute (between live part and ground, between terminals of different poles, between terminals of the same poles when main contacts are open, between main circuit and auxiliary contact)
Vibration Resistance	100 m/s ² (10 to 55 Hz)
Shock Resistance	1000 m/s ²
Life	10,000 operations minimum (6 operations per minute)
Terminal Style	Main terminal: M5 stud screw Auxiliary contact and alarm contact: Tab terminal #80
Weight (Approx.)	1-pole: 100g, 2-pole: 200g, 3-pole: 300g

Flush Silhouette

Control Units

Display Lights

Display Units

Safety Products

Terminal Blocks

Comm Terminals

AS-Interface

Relays & Timers

Sockets

Circuit Protectors

Power Supplies

PLCs & SmartRelay

Operator Interfaces

Sensors

Control Stations

Explosion Protection

References

NRBM Series Circuit Protectors

Type No. Development

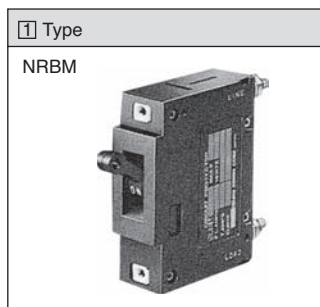

4 Auxiliary Contact / Alarm Contact

Without	(Code) 00
With auxiliary contact	11
With alarm contact	21

Note:
On the multi-pole types, one auxiliary contact is provided on the left side or one alarm contact is provided on the right side as viewed from the front.

5 Inertia Delay

Without	(Code) Blank
With	F

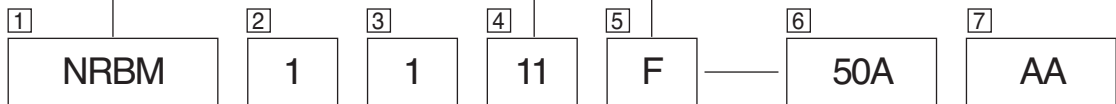

2 No. of Poles

1-pole	(Code) 1
2-pole	2
3-pole	3

Note:
NRBM is also available in standard 2, 3, or 4-pole types with identical internal circuits, ratings and curves in each pole. Simultaneous-throw and simultaneous-break (all levers interconnected) is standard.

3 Internal Circuit

Series Trip (Current Trip)	(Code) 1
----------------------------	----------

6 Rated Current

• Rated Current	
1A	15A
2A	20A
3A	25A
5A	30A
7.5A	40A
10A	50A

7 Time Delay Curve

	Time Delay Curve
AC type [50/60Hz]	AA
	BA
	MA
DC type	AD
	MD

NRBM (Lever Type)

Specify a rated current and time delay curve in place of **6** **7** . Package Quantity: 1

Internal Circuit	No. of Poles	Inertia Delay	Auxiliary Contact Alarm Contact	Type No. (Ordering Type No.)	Code for Ordering		
					6 Rated Current	7 Time Delay Curve	
Series Trip Current Trip	1	Without	Without	NRBM1100- 6 7	1A 2A 3A 5A 7.5A 10A 15A 20A 25A 30A 40A 50A	AA BA MA AD MD	
			w/Auxiliary Contact	NRBM1111- 6 7			
			w/Alarm Contact	NRBM1121- 6 7			
		With	Without	NRBM1100F- 6 7			
			w/Auxiliary Contact	NRBM1111F- 6 7			
			w/Alarm Contact	NRBM1121F- 6 7			
	2	Without	Without	NRBM2100- 6 7			
			w/Auxiliary Contact	NRBM2111- 6 7			
			w/Alarm Contact	NRBM2121- 6 7			
			With	Without			NRBM2100F- 6 7
				w/Auxiliary Contact			NRBM2111F- 6 7
				w/Alarm Contact			NRBM2121F- 6 7
		3	Without	Without			NRBM3100- 6 7
				w/Auxiliary Contact			NRBM3111- 6 7
				w/Alarm Contact			NRBM3121- 6 7
With	Without	NRBM3100F- 6 7					
	w/Auxiliary Contact	NRBM3111F- 6 7					
	w/Alarm Contact	NRBM3121F- 6 7					

Internal Circuits

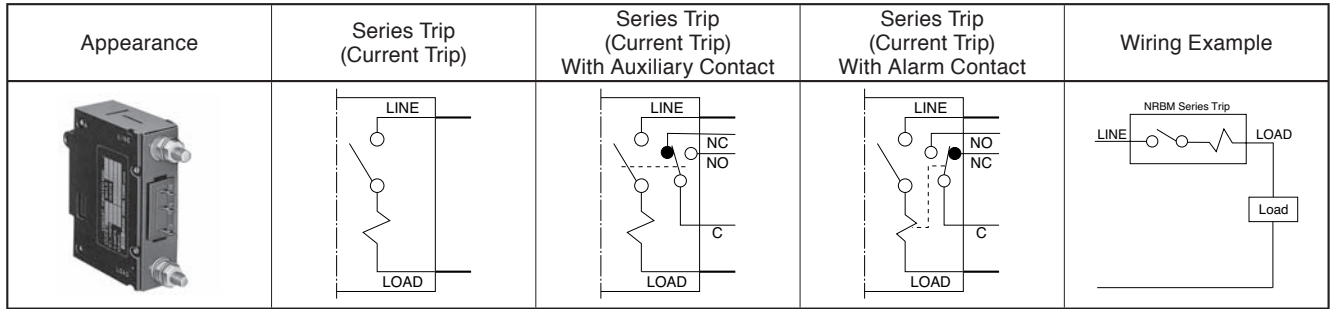

Overcurrent - Time Delay Characteristics (sec at 25°C)

Type	Time Delay Curve	Percent of Rated Current							
		100%	125%	150%	200%	400%	600%	800%	1000%
AC 50/60Hz	AA	No Trip	15-120	8-45	3-15	0.48-2.5	0.06-0.8	0.007-0.13	0.005-0.04
	BA	No Trip	0.75-10	0.45-3.5	0.22-1.3	0.045-0.22	0.012-0.12	0.005-0.06	0.004-0.03
	MA	No Trip	70-900	30-260	10-70	1.8-11	0.5-4	0.009-1.1	0.006-0.2
DC	AD	No Trip	10-130	6-55	2.6-20	0.5-3.5	0.14-1.4	0.008-0.7	0.005-0.35
	MD	No Trip	35-400	20-180	8-60	1.6-10	0.6-4.5	0.01-2	0.007-0.5

Note: Circuit protectors with inertia delay may have a slightly longer time delay at 600% or higher.

Time Delay Curves

For AC

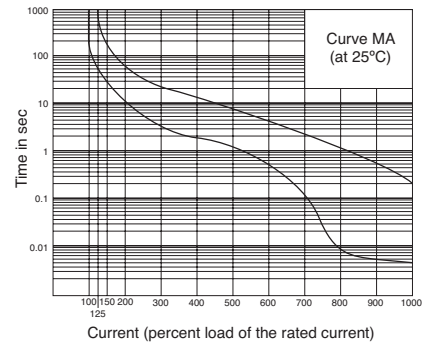
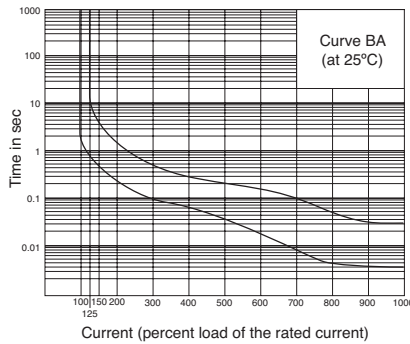
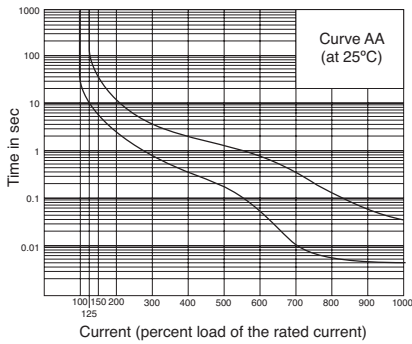

For DC

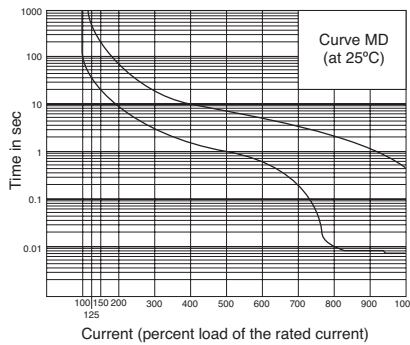
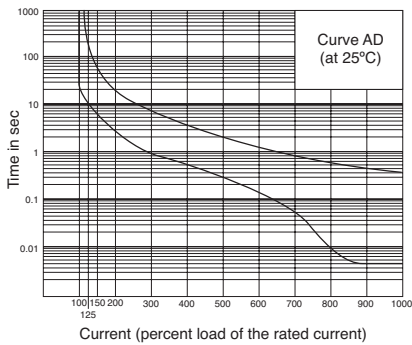

Dimensions

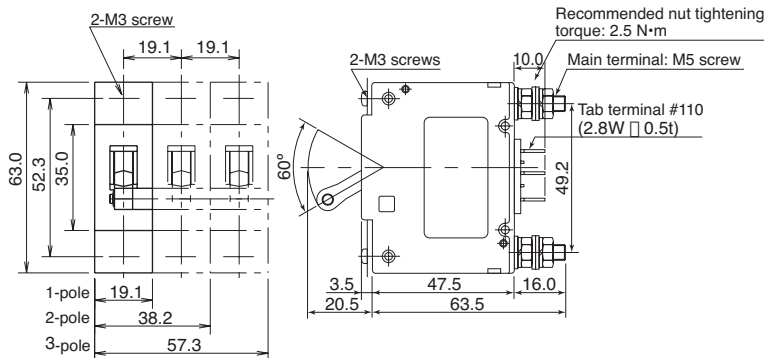

Mounting Hole Layout

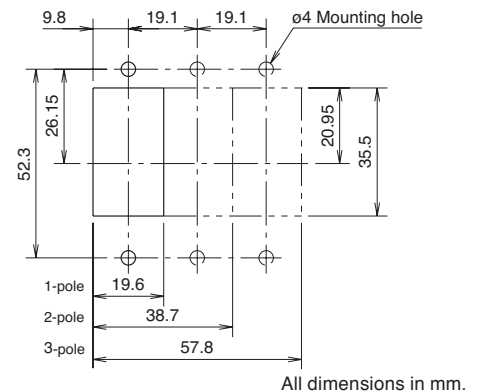

- Flush Silhouette
- Control Units
- Display Lights
- Display Units
- Safety Products
- Terminal Blocks
- Comm Terminals
- AS-Interface
- Relays & Timers
- Sockets
- Circuit Protectors
- Power Supplies
- PLCs & SmartRelay
- Operator Interfaces
- Sensors
- Control Stations
- Explosion Protection
- References

NRBM Series Circuit Protectors

Circuit Protector with Inertia Delay

Circuit protectors equipped with inertia delay do not respond to high inrush currents caused by transformer or lamp loads, but perform the specified interruption on the subsequent overcurrents.

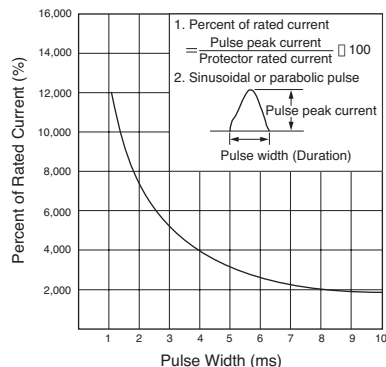

Note: Inertia delay is designed not to trip on a pulse of 20 times the rated current (peak value) for a duration of 8 ms. See the above curve.

Impedance and Coil Resistance (at 25°C)

Rated Current (A)	For AC 50/60Hz Impedance (Ω)	For DC Resistance (Ω)
	Curves AA, BA, and MA	Curves AD and MD
1	1.1	1
2	0.245	0.227
3	0.11	0.091
5	0.039	0.035
7.5	0.018	0.015
10	0.0124	0.0088
15	0.0065	0.005
20	0.0047	0.003
25	0.0032	0.0023
30	0.0031	0.0019
40	0.002	0.001
50	0.0016	0.0006

Note: Tolerance: ±25% (up to 20A), ±50% (25A or higher)

Voltage Drop due to Coil Resistance or Impedance

The internal resistance or impedance of a circuit protector tends to be larger for a smaller rated current. Therefore, when circuit protectors of a small rated current are used for a power-supply switch, voltage drop should be taken into consideration. Internal resistance also varies with time delay curves in spite of the same rated current, which should be also considered during installation.

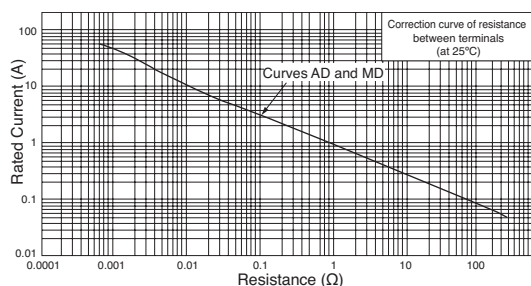
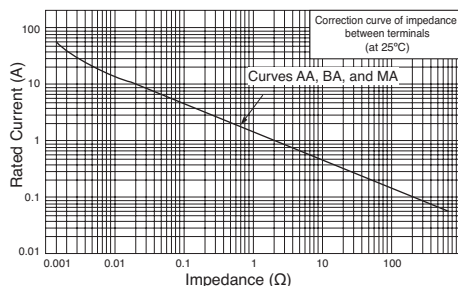

Temperature Correction Curve

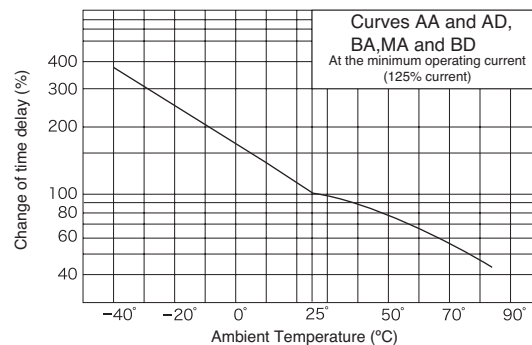

Time Delay Curve and Ambient Temperature

Since the NRBM series circuit protectors employ an electromagnetic tripping system, the rated current (trip current) is not affected by ambient temperatures, but the time delay varies with the oil viscosity in the oil dash pot. Lower oil viscosity at higher temperatures results in shorter delay, whereas at lower temperatures the delay will be prolonged.

The time delay curves on the preceding page are at 25°C. With reference to these curves, time delays can be corrected.

Instructions

Panel Mounting Screw Length

Select a proper screw length according to the table.

Panel thickness (mm)	0.8	1.0	1.2	1.4	1.6	1.8	2.0	2.3	2.6	3.2
Without washer	(4)	(4)	5	5	5	5	5	6	6	6
With plain washer (0.5 mm thick)	5	5	5	5	6	6	6	6	6	(7)
With spring washer (0.7 mm thick)	5	5	5	5	6	6	6	6	6	7
With plain washer (0.5 mm thick) and spring washer (0.7 mm thick)	6	6	6	6	6	6	6	(7)	(7)	8

Note: Avoid using screws in the parenthesized lengths whenever possible.

M3 Screw Mounting

Tightening torque: 0.5 N·m minimum
 Tightening strength: 1.1 N·m maximum

Installation Angle

Designed to be mounted on a vertical surface in principle, the circuit protector must be mounted on a surface within 10° from a vertical plane. If the circuit protector is mounted on a horizontal surface or at any angle other than specified, the characteristics will be changed.

Multi-pole Type



Multi-pole types such as 2- or 3-pole types are assembled by IDEC. Because of their characteristics, 1-pole type protectors cannot be combined to provide multi-pole types.

NRC Series Circuit Protectors

Small and high-performance circuit protectors with rated interrupting capacity 2500A (2-pole type: 1500A) [ Molded case circuit breaker]
Suited for FA related equipment and control panels.

- Sliding knob operator or lever operator
- Two-way mounting: DIN rail mounting or screw mounting.
- Mounting bracket is available for panel mounting.
- Easy-to-view trip indication
- Available with auxiliary contacts
- Variety of rated currents and time delay curves
- Hydraulic-magnetic tripping system and safe trip-free mechanism
- Shockproof construction to withstand shocks and vibrations

This product is recognized by Underwriters Laboratories under UL1077 as a "Supplementary Protector".

Applicable Standards	Certification Mark	Certification Organization / File No.
UL1077		UL File No. E68029
CSA C22.2 No. 235		No. LR83454
Electrical Appliance and Material safety Law Technical Standard		JET

For details, see the list of standard certified products in the back of this catalog.

Specifications

Type	AC	DC
Protection Method	Hydraulic-magnetic tripping system	
Internal Circuit	Series trip Series trip (with auxiliary contact)	
No. of Poles	1-, 2-pole	
Rated Voltage	250V AC, 50/60 Hz	65V DC
Rated Current	0.3A, 0.5A, 1A, 2A, 3A, 4A, 5A, 7A, 10A, 15A, 20A, 30A	
Rated Interrupting Capacity	 220V AC, 50/60 Hz, 2500A (2-pole type: 1500A)	65V DC, 1500A (2-pole type: 750A)
Auxiliary Contact Rating	SPDT (contact output) 250V AC / 3A (resistive load), 65V DC / 1A (resistive load)	
Reference Temperature	40°C	
Operating Temperature	-10 to +60°C (no freezing)	
Operating Humidity	45 to 85% RH (no condensation)	
Insulation Resistance	100MΩ min. (with 500V DC megger)	
Dielectric strength	2000V AC, 1 minute (between live part and ground, between terminals of different poles, between terminals of the same pole when main contacts are open, between main circuit and auxiliary contact)	
Vibration resistance	100 m/s ² (10 to 55 Hz) at the rated current	
Shock resistance	500 m/s ² at the rated current (auxiliary contact: 300 m/s ²)	
Life	Electrical: 6,000 operations (6 operations per minute at the rated current) Mechanical: 4,000 operations (6 operations per minute)	
Terminal Style	Main terminal: M4 screw terminal (20A max.), M5 screw (30A) Auxiliary terminal: M3.5 screw terminal	
Weight (Approx.)	1-pole type: 115g, 2-pole type: 230g	

Rated	UL Rating	CSA Rating
Rated Voltage	AC: 250V AC 50/60 Hz DC: 65V DC	
Rated Current	0.3A, 0.5A, 1A, 2A, 3A, 5A, 7A, 10A, 15A, 20A, 30A	
Rated Interrupting Capacity	1-pole	AC: 2,500A DC: 1,500A
	2-pole	AC: 1,500A DC: 1,000A
Auxiliary Contact Rating	250V AC / 3A, 65V DC / 1A	

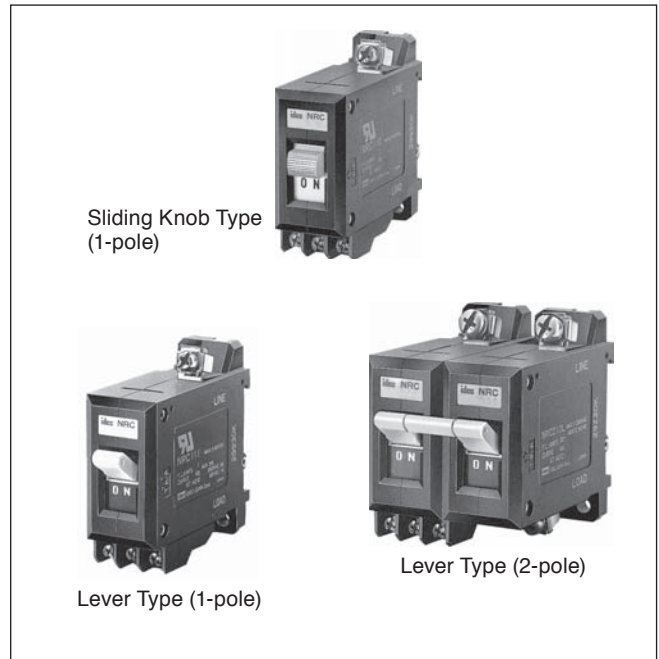

Applications

NRC series circuit protectors are small, high-performance overcurrent protectors developed for use in control circuits and small electrical equipment. Due to their ability to be re-set many times, a wide range of applications, including replacement of various fuses as in relay circuits, motor circuits, heater circuits, transformers, solenoids, solenoid valves, semiconductors, and many more.

Panels

Automatic control boards, instrumentation boards, power supply boards, electronic control boards, explosion-protected panels.

Machine Tools

Milling machines, drilling machines, grinding machines, presses, electric discharge machines.

Industrial Machines

Injection molding machines, printing presses, spinning machines, elevators, conveyors, cranes.

Chemical and Food Processing Machines

Packaging machines, stirrers, centrifuges, dryers, vacuum equipment.

Communication and Measuring Equipment

Industrial instruments, recording instruments, oscilloscopes, audio systems.

Office Machines

Computer power lines and peripheral equipment, copying machines.

Other Machines and Equipment

Medical equipment, vending machines, hairdresser's equipment, recreation and game machines.

Flush Silhouette

Control Units

Display Lights

Display Units

Safety Products

Terminal Blocks

Comm Terminals

AS-Interface

Relays & Timers

Sockets

Circuit Protectors

Power Supplies

PLCs & SmartRelay

Operator Interfaces

Sensors

Control Stations

Explosion Protection

References

NRC Series Circuit Protectors

Sliding Knob Operator Type

Specify a rated current in place of [2].

Package Quantity: 1

No. of Poles	Auxiliary Contact	Type No. (Ordering Type No.)	Designation Code
			[2] Rated Current
1	Without	NRC110- [2] AA	0.3A, 0.5A, 1A, 2A, 3A, 5A, 7.5A, 10A, 15A, 20A, 30A
		NRC110- [2] EA	
		NRC110- [2] AD	
		NRC110- [2] ED	
	With	NRC111- [2] AA	
		NRC111- [2] EA	
		NRC111- [2] AD	
		NRC111- [2] ED	

Lever Operator Type

Specify a rated current in place of [2].

Package Quantity: 1

No. of Poles	Auxiliary Contact	Type No. (Ordering Type No.)	Designation Code
			[2] Rated Current
1	Without	NRC110L- [2] AA	0.3A, 0.5A, 1A, 2A, 3A, 5A, 7.5A, 10A, 15A, 20A, 30A
		NRC110L- [2] EA	
		NRC110L- [2] AD	
		NRC110L- [2] ED	
	With	NRC111L- [2] AA	
		NRC111L- [2] EA	
		NRC111L- [2] AD	
		NRC111L- [2] ED	
2	Without	NRC210L- [2] AA	0.3A, 0.5A, 1A, 2A, 3A, 5A, 7.5A, 10A, 15A, 20A, 30A
		NRC210L- [2] EA	
		NRC210L- [2] AD	
		NRC210L- [2] ED	
	With	NRC211L- [2] AA	
		NRC211L- [2] EA	
		NRC211L- [2] AD	
		NRC211L- [2] ED	

Ordering Information

Specify the type No., rated current and time delay curves.

Note: Use the AC type for use in AC circuits and DC type for use in DC circuits. AC types are not interchangeable with DC types.

[Example]

NRC111 - 30A · AA

[1] Type No. [2] Rated Current [3] Time Delay Curve

NRC110	Sliding knob operator (w/o auxiliary contact)	1-pole
NRC111	Sliding knob operator (w/auxiliary contact)	1-pole
NRC110L	Lever operator (w/o auxiliary contact)	1-pole
NRC111L	Lever operator (w/auxiliary contact)	1-pole
NRC210L	Lever operator (w/o auxiliary contact)	2-pole
NRC211L	Lever operator (w/auxiliary contact)	2-pole



0.3A, 0.5A, 1A, 2A, 3A, 5A, 7A,
10A, 15A, 20A, 30A

AA	Slow delay type for AC
EA	Fast delay type for AC
AD	Slow delay type for DC
ED	Fast delay type for DC

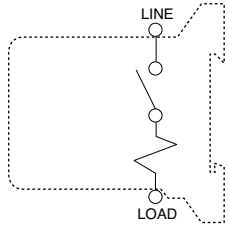
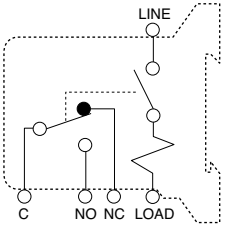
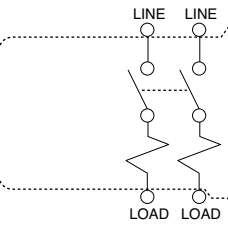
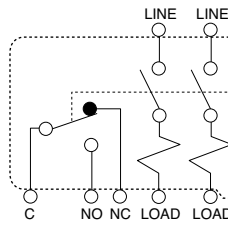
Internal Circuits and Terminal Arrangements

Type	1-pole w/o auxiliary contact	1-pole w/auxiliary contact	2-pole w/o auxiliary contact	2-pole w/auxiliary contact
	NRC110, NRC110L	NRC111, NRC111L	NRC210L	NRC211L
Series Trip				

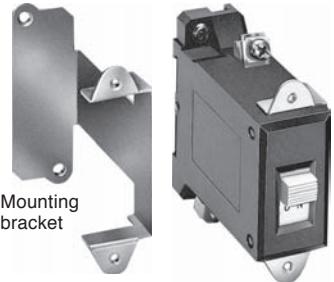
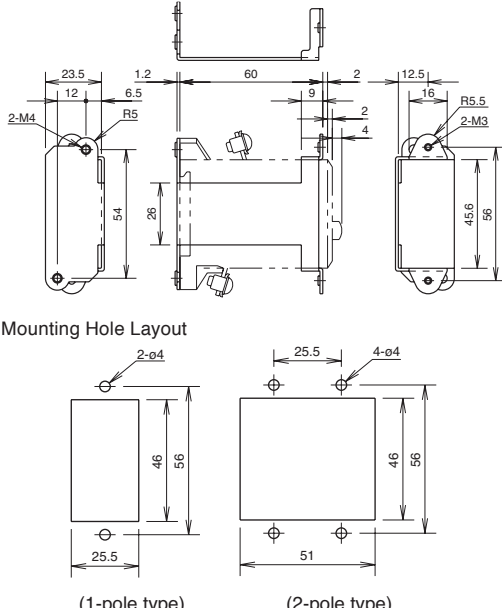
Accessories

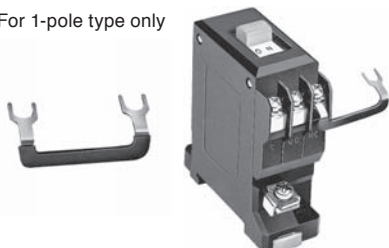
Product / Appearance	Type No.	Ordering Type No.	Package Quantity	Description and Dimensions
<p>Mounting Bracket</p>  <p>Mounting bracket</p> <p>(Mounting example of 1-pole type)</p> <p>Note 1: The circuit protectors with auxiliary contacts (NRC111, NRC111L, and NRC211L) cannot be used with mounting brackets.</p> <p>Note 2: For NRC210L (2-pole type), use two mounting brackets for 1 unit (one for each side).</p> <p>Note 3: Wiring can be performed from the rear by using screw terminal adapter (NRC-T).</p>	NRC-M	NRC-MPN02	2	<p>Dimensions</p>  <p>Mounting Hole Layout</p> <p>(1-pole type) (2-pole type)</p>
<p>Screw Terminal Adapter (for M4/20A max.)</p>  <p>(Two adapters for 1 unit)</p>	NRC-T	NRC-TPN10	10	<p>Use screw terminal adapter for wiring from the rear using the mounting bracket. When screw terminal adapters are used, the terminal length is extended by 12mm. Screw terminal adapters cannot be used for 30A types with M5 terminals.</p>
<p>Auxiliary Terminal Jumper</p> <p>For 1-pole type only</p> 	NRC-J	NRC-JPN10	10	<p>Jumper for auxiliary contact terminal Rated current: 3A</p>

Flush Silhouette
Control Units
Display Lights
Display Units
Safety Products
Terminal Blocks
Comm Terminals
AS-Interface
Relays & Timers
Sockets
Circuit Protectors
Power Supplies
PLCs & SmartRelay
Operator Interfaces
Sensors
Control Stations
Explosion Protection
References

NRC Series Circuit Protectors

Dimensions and Mounting Hole Layout (1-pole Type)

Type	Type No.	Dimensions	Mounting Hole Layout
Sliding Knob Operator (1-pole)	NRC110 (Without Auxiliary Contact)		<p>Mounting Hole Layout</p>
	NRC111 (With Auxiliary Contact)		
Lever Operator (1-pole)	NRC110L (Without Auxiliary Contact)		
	NRC111L (With Auxiliary Contact)		

The circuit protectors without auxiliary contacts can be mounted to the panel by using the mounting bracket (optional). See the "Accessories" for the dimensions and mounting hole layout when the mounting brackets are used.

Dimensions and Mounting Hole Layout (2-pole Type)

Type	Type No.	Dimensions	Mounting Hole Layout
Lever Operator (2-pole)	NRC210L (Without Auxiliary Contact)		<p>Mounting Hole Layout</p>
	NRC211L (With Auxiliary Contact)		

The circuit protectors without auxiliary contacts can be mounted to the panel by using the mounting bracket (optional).

Overcurrent - Time Delay Characteristics (sec at 40 °C)

Type	Time Delay Curve	Percent of Rated Current							
		100%	125%	150%	200%	400%	600%	800%	1000%
AC	AA	No Trip	40-240	10-50	3.5-18	0.9-4	0.35-2	0.07-1.2	0.01-0.5
	EA	No Trip	0.05-0.4	0.03-0.17	0.02-0.07	0.008-0.025	0.005-0.018	0.004-0.017	0.004-0.017
DC	AD	No Trip	40-240	10-50	3.5-18	0.6-3	0.008-0.5	0.005-0.09	0.004-0.07
	ED	No Trip	0.04-0.4	0.025-0.15	0.015-0.06	0.007-0.025	0.005-0.018	0.004-0.017	0.004-0.017

Time Delay Curves

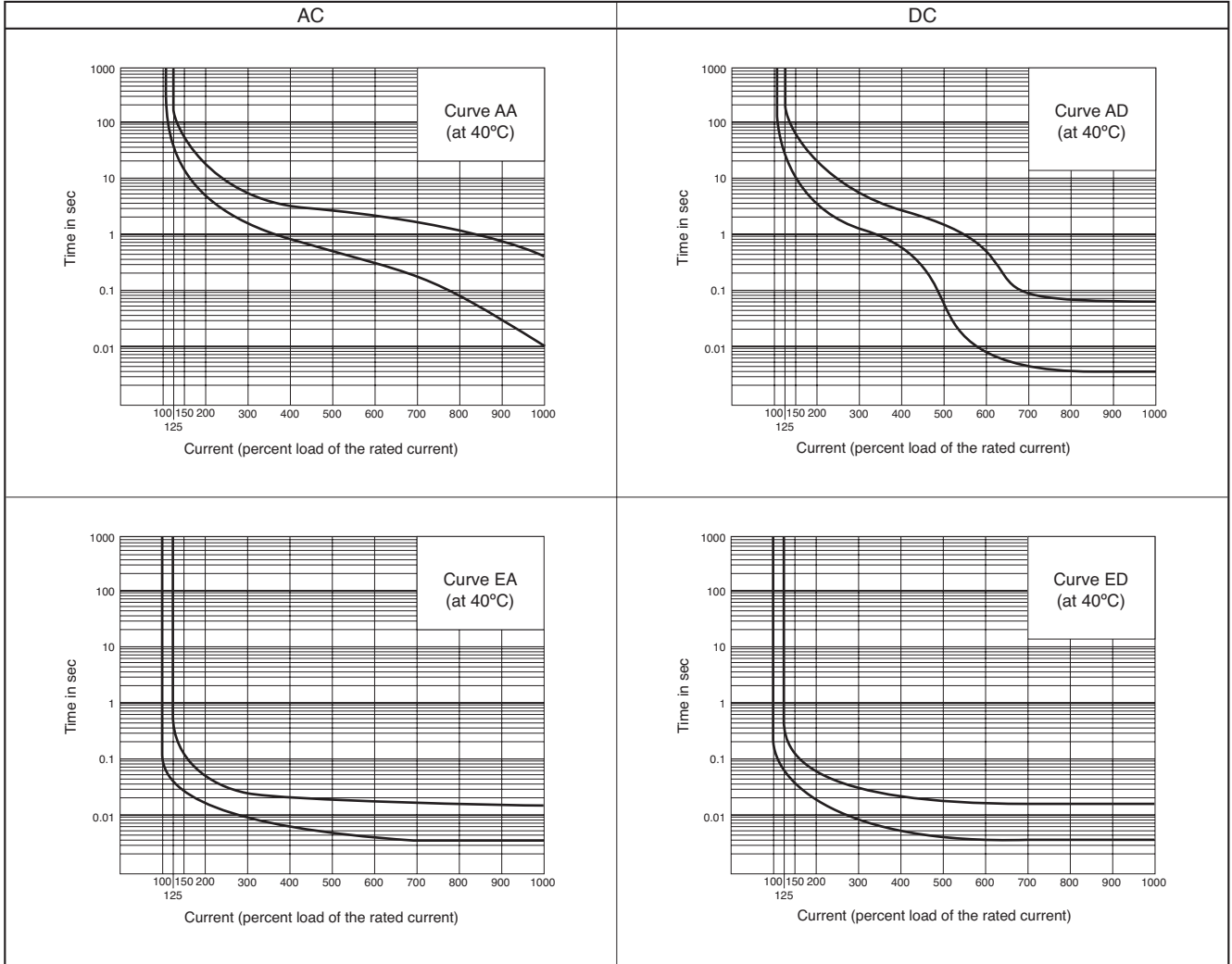

- Flush Silhouette
- Control Units
- Display Lights
- Display Units
- Safety Products
- Terminal Blocks
- Comm Terminals
- AS-Interface
- Relays & Timers
- Sockets
- Circuit Protectors**
- Power Supplies
- PLCs & SmartRelay
- Operator Interfaces
- Sensors
- Control Stations
- Explosion Protection
- References

NRC Series Circuit Protectors

Coil Resistance and Impedance (at 40°C)

Rated Current	For AC 50/60Hz Impedance (Ω)	For DC Resistance (Ω)
0.3A	15.1	25.6
0.5A	5.58	9.04
1A	1.54	2.33
2A	0.341	0.548
3A	0.162	0.261
5A	0.061	0.099
7A	0.031	0.048
10A	0.017	0.026
15A	0.008	0.013
20A	0.0058	0.0075
30A	0.0039	0.0046

Tolerance: 0.3A to 3A ±10%
5A to 30A ±25%

Voltage Drop due to Coil Resistance or Impedance

The internal resistance or impedance of circuit protector terminals tends to be larger for smaller rated currents. Therefore, when circuit protectors of small rated currents are used, voltage drop should be taken into consideration.

AC Coil Impedance between Terminals

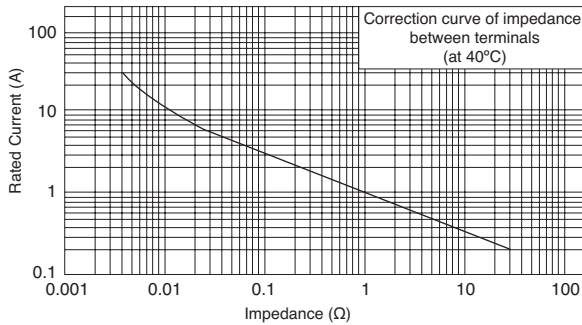

Tolerance: 0.3A to 3A ±10%
5A to 30A ±25%

DC Coil Resistance between Terminals

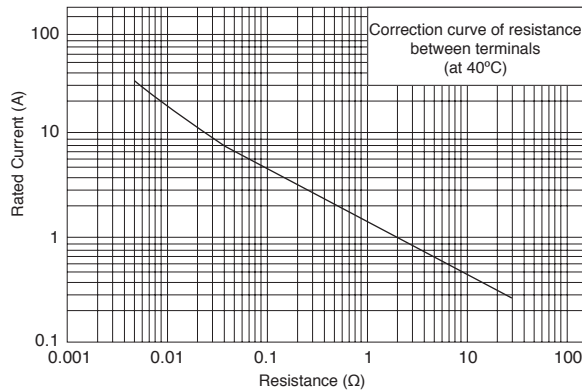

Tolerance: 0.3A to 3A ±10%
5A to 30A ±25%

Wiring Example

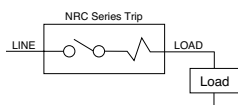

Temperature Correction Curve

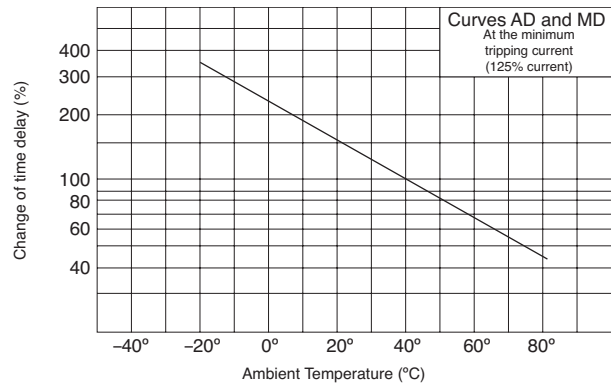

Time Delay Curve and Ambient Temperature

Since the NRC series circuit protectors employ an electromagnetic tripping system, the rated current (trip current) is not affected by the ambient temperatures but the time delay varies with the oil viscosity in the oil dash pot. Lower oil viscosity at higher temperatures results in shorter delay, whereas at lower temperatures the delay will be prolonged.

The above time delay curves are at 40°C. With reference to these curves, time delays can be corrected.

Selection Guide

Select an appropriate circuit protector with a required delay curve and rated current in consideration of the characteristics of the circuit or equipment to be protected.

When starting an inductive load, the inrush current reaches up to over ten times the rated current. Select the rated current to prevent tripping at starting current.

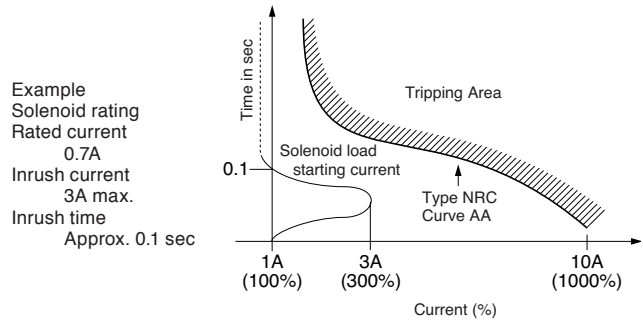

For solenoid protection such as the above example, NRC circuit protector for the rated current 1A is suited.

For semiconductor element, the joint-use of short delay fuse for semiconductor protection is more effective.

Installation Angle

Designed to be mounted on a vertical surface in principle, the circuit protector should be mounted on a surface within 10° from a vertical plane.

If the protector is mounted on a horizontal surface or at any angle other than specified, the characteristics will be changed.

NRF Series Circuit Protectors

Snaps into a 16-mm-diameter hole

Wide variety of applications such as office automation equipment

- 16-mm-dia fuse holder size
- More than 1,000 repeat operations
- Snap-on mounting
- Visible trip indicator
- Variety of rated currents
- Available with auxiliary contact which can be used to make an alarm or control circuit
- Solder or quick-connect terminations
- Round design and colorful bezels
- Mounting on 35-mm-width DIN rails is made possible by using a special adapter
- Cycling trip-free mechanism

This product is recognized by Underwriters Laboratories under UL1077 as a "Supplementary Protector."



Applicable Standards	Certification Mark	Certification Organization / File No.
UL1077		UL File No. E68029
CSA C22.2 No. 235 (Note 1)		No. LR83454
EN60934 (Note 2)		TÜV Product Service
GB17701		CCC No. 2005010309151798

For details, see the list of standard certified products in the back of this catalog.
 Note 1: Only NRF series circuit protectors without manual OFF mechanism are certified by CSA.

Note 2: NRF110, rated current 8A, 10A, and 15A, without manual OFF mechanism

Types

• Specify a rated current and the bezel color code in place of [1] [2]. Package Quantity: 1

Auxiliary Contact	Internal Circuit	Manual OFF Mechanism	Type No. (Ordering Type No.)	Standard	Designation Code	
					[1] Rated Current	[2] Bezel Color
w/o Auxiliary Contact		Without	NRF110 [2]-[1]	UL CSA	0.3A, 0.5A	
			NRF110 [2]-[1]	UL CSA TÜV (Note)	1A, 2A, 3A, 5A, 8A, 10A, 15A	
		With	NRF210 [2]-[1]	UL	0.3A, 0.5A	
			NRF210 [2]-[1]	UL	1A, 2A, 3A, 5A, 8A, 10A, 15A	
w/Auxiliary Contact		Without	NRF111 [2]-[1]	UL CSA	0.3A, 0.5A, 1A, 2A, 3A, 5A, 8A, 10A, 15A	
		With	NRF211 [2]-[1]	UL CSA		

Bezel Color	Code
Black	Blank
Green	G
Red	R
Blue	S
White	W
Yellow	Y

Note: TÜV approved models are for 8A, 10A, and 15A only. When ordering the TÜV approved models, specify "-EN" at the end of the Type No.

Ordering Information

When ordering, specify the Type No. the rated current, and the bezel color code.

[Example]

NRF 2 11 R - 3A

- Type: NRF
- Manual OFF Mechanism: 2 (With)
- Auxiliary Contact: 11 (With)
- Rated Current: 3A
- Bezel Color: R (Red)

Rated Current
0.3A, 0.5A, 1A, 2A, 3A, 5A, 8A, 10A, 15A

Bezel Color	Code
Black	Blank (standard color)
Green	G
Red	R
Blue	S
White	W
Yellow	Y

• Wiring Example

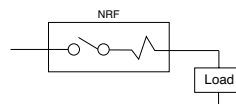

• Manual OFF Mechanism

Manual OFF mechanism opens the main contacts by pressing the button, convenient for checking the circuit with power OFF. When manually turning OFF, make sure that the current is not applied (under no-load condition).

Flush Silhouette

Control Units

Display Lights

Display Units

Safety Products

Terminal Blocks

Comm Terminals

AS-Interface

Relays & Timers

Sockets

Circuit Protectors

Power Supplies

PLCs & SmartRelay

Operator Interfaces

Sensors

Control Stations

Explosion Protection

References

NRF Series Circuit Protectors

Specifications

Protection Method	Thermal tripping
Internal Circuit	Series trip Series trip (w/auxiliary contact)
No. of Poles	1 pole
Rated Voltage	250V AC, 32V DC
Rated Current	0.3A, 0.5A, 1A, 2A, 3A, 5A, 8A, 10A, 15A
Minimum Applicable Load	24V AC/DC 100mA (reference value)
Rated Interrupting Capacity	300 mA to 5A: Rated current × 6 8, 10, and 15A: Rated current × 10
Auxiliary Contact Rating	1NO (contact output) 125V AC / 32V DC, 50mA
Reference Temperature	25°C
Operating Temperature	-10 to +60°C (no freezing)
Operating Humidity	45 to 85% RH (no condensation) (Note 1)
Trip Time (at 25 °C)	• No trip at the rated current • Within 1 hour at 135% the rated current
Reset Time	60 sec minimum (Note 2)
Vibration Resistance	100 m/s ² (10 to 55 Hz)
Shock Resistance	Damage limits: 1000 m/s ² , Operating extremes: 500 m/s ²
Life	• Overcurrent durability: 1,000 operations minimum (tripping at 200% the rated current) • Mechanical life (with manual OFF mechanism): 240 operations minimum (switching at no load)
Insulation Resistance	100 MΩ minimum (500V DC megger)
Dielectric Strength	• Between main contacts and between main contact and ground: 2000V AC, 1 minute • Between main and auxiliary contacts: 1500V AC, 1 minute
Terminal Style	Main terminal: Tab terminal #250 Auxiliary contact terminal: 1.4W × 0.2mm thick solder terminal
Weight (Approx.)	15g

Note 1: The rated current is the value at the reference ambient temperature of 25°C, and varies with the operating temperature. The rated current can be corrected according to the temperature correction curve.

Note 2: Reset time is the value at the reference ambient temperature of 25°C.

Applications

NRF series circuit protectors are small, high-performance overcurrent protectors developed for use in control circuits and small electrical equipment. Because they can be easily reset, they are suited for use in relay circuits, motor circuits, heater circuits, transformers, solenoids, solenoid valves, semiconductor circuits, and many other applications.

[Application Examples]

• Office Automation Equipment

Copiers, shredders, personal computers, word processors, fax machines, printers, computer terminals, communication equipment, and power supplies.

• Measuring Instruments

Electrical measuring instruments, industrial meters, analyzers, recorders, data processors, test equipment, and chemical equipment

• Industrial Machines

CNC equipment, robots, molding machines, processing machines, packaging machines, and carriers

• Business machines

Medical equipment, vending machines, hairdresser's equipment, recreation and game machines, and small printing machines

• Electric Controller and Instrumentation Equipment

Automatic control devices, electronic equipment, and instrumentation boards

Time Delay Curves

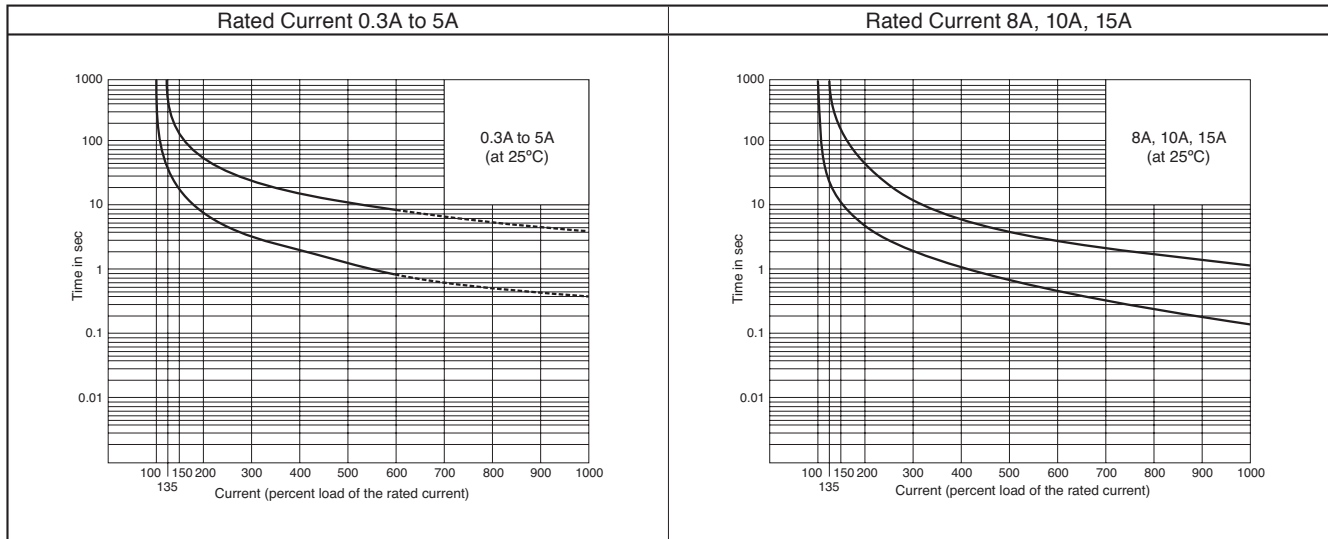

Note: Dashed lines are reference values.

Rated Current vs Internal Resistance

Rated Current	Internal Resistance (Ω) $\pm 15\%$	Remarks
0.3A	9.08	at 25°C
0.5A	3.27	
1A	0.81	
2A	0.235	
3A	0.0922	
5A	0.0503	
8A	0.0085	
10A	0.0095	
15A	0.0064	

The internal resistance tends to be larger for smaller rated currents. When the circuit protector is used in a low-voltage circuit, voltage drop should be taken into consideration.

Temperature Correction Curve

The rated current is based on an ambient temperature of 25°C. Since a thermal tripping method is employed, the rated current should be corrected according to the ambient temperature with reference to the curves shown below.

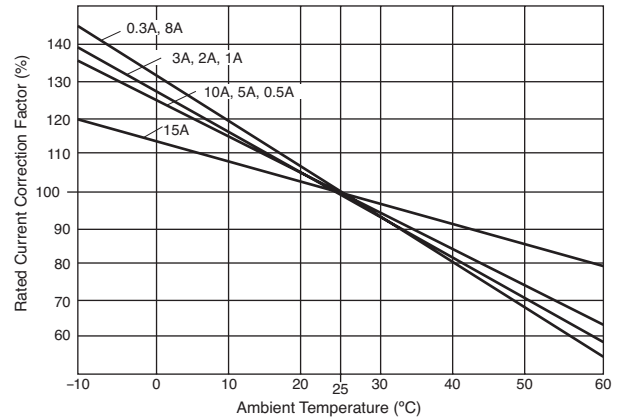

Dimensions

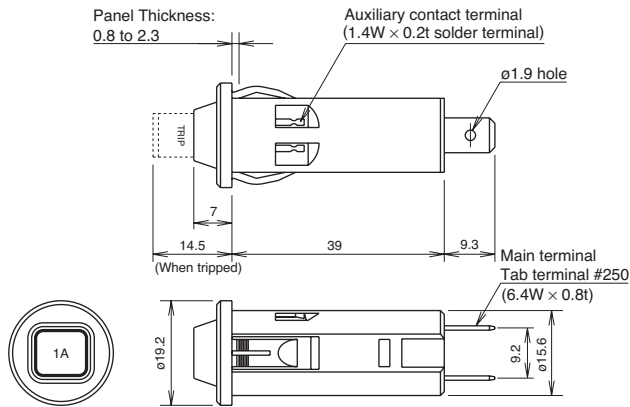

Mounting Hole

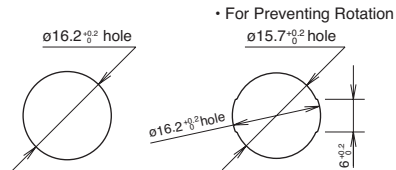

* Chamfering on the front edge of the mounting hole is recommended for easy insertion.

Accessories (optional)

• 35-mm-wide DIN Rail Mount Adapter

Type No.	Ordering Type No.	Package Quantity
NRF-D	NRF-DPN05	5

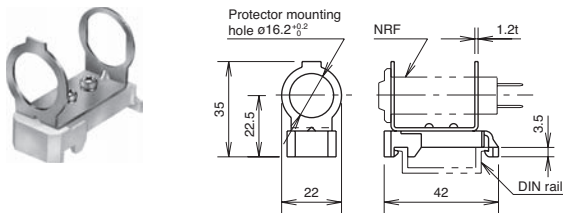

• Surface Mount Adapter

Type No.	Ordering Type No.	Package Quantity
NRF-M	NRF-MPN10	10

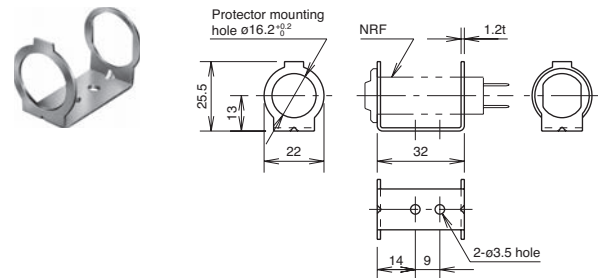

All dimension in mm.

Instructions

- Since the NRF is designed for protection against overload, it should be used within the rated interrupting capacity. An excessive overcurrent may affect the bimetal characteristics or damage the internal mechanism.
- After tripping, the NRF cannot be reset until the bimetal cools down. Allow the NRF at least 60 seconds before resetting. When the NRF is used at an ambient temperature higher than the reference temperature, resetting sometimes fails even after 60 seconds because it takes a long time to cool down the bimetal.
- The NRF may not trip at an instantaneous overcurrent due to its principle.
- The NRF is shipped in the ON status. To confirm operation of the models without manual OFF mechanism, apply approximately 200% the rated current to trip the NRF.
- When installing quick connect receptacles to the terminals, hold the NRF body and press it into the quick connect receptacles.
- Unlike conventional switches, the models with manual OFF mechanism are not suited for frequent switching due to their construction. (Their mechanical life is 240 operations at minimum when switching at no load.)
- The models with manual OFF mechanism should be operated without load.

- Flush Silhouette
- Control Units
- Display Lights
- Display Units
- Safety Products
- Terminal Blocks
- Comm Terminals
- AS-Interface
- Relays & Timers
- Sockets
- Circuit Protectors
- Power Supplies
- PLCs & SmartRelay
- Operator Interfaces
- Sensors
- Control Stations
- Explosion Protection
- References

NRP Series PC Board Circuit Protectors

Higher economic efficiency than a fuse

SIL type subminiature circuit protectors adopting IC terminal arrangements, and mountable directly on PC boards. Simple construction and high performance applying a positive load reversing mechanism by IDEC's original design. Unlike fuses, the thermal trip mode (bimetal type) eliminates erroneous interruption due to inrush currents. Rated current can be selected to meet the load. Circuits with high inrush currents can be protected against overloads (unlike fuses).

Reusable 200 operations (tripping at 200% the rated current) with higher economic efficiency, and less maintenance than fuses.

Available in slim and flat types. Slim types (can be mounted on PC boards by using pick and place machines)

Available in non-sealed and sealed types. With the sealed type, cleaning after soldering is possible.

With a manual OFF mechanism, convenient for circuit checkups

This product is recognized by Underwriters Laboratories under UL1077 as a "Supplementary Protector."

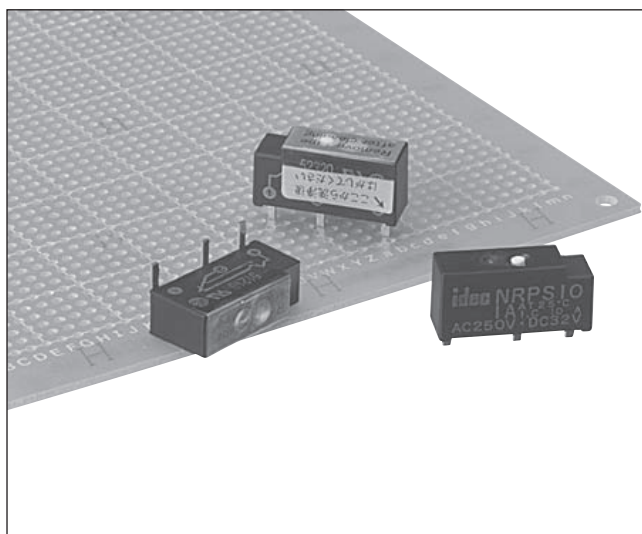

Applicable Standard	Certification Mark	Certification Organization File No.
UL1077		UL File No. E68029
CSA C22.2 No. 235		No. LR65560

For details, see the list of standard certified products in the back of this catalog.

Types

Specify a rated current in place of □.

Type	Appearance	Type No.	Ordering Type No.	□ Rated Current	Contact	Internal Circuit (Note)	Package Quantity	
NRPS (Slim Type)	Non-sealed		NRPS10-□	NRPS10-□PN10	1A, 1.6A, 2A, 3.15A, 4A, 5A, 6A	1NC		10
	Sealed (Tape-sealed)		NRPS10-G□	NRPS10-G□PN10	1A, 1.6A, 2A, 3.15A, 4A, 5A, 6A	1NC		10
NRPF (Flat Type)	Non-sealed		NRPF10-□	NRPF10-□PN10	1A, 1.6A, 2A, 3.15A, 4A, 5A, 6A	1NC		10
	Sealed (Tape-sealed)		NRPF10-G□	NRPF10-G□PN10	1A, 1.6A, 2A, 3.15A, 4A, 5A, 6A	1NC		10
NRPS (Slim Type)	Non-sealed		NRPS11-□	NRPS11-□PN10	1A, 1.6A, 2A, 3.15A, 4A, 5A, 6A	SPDT		10
	Sealed (Tape-sealed)		NRPS11-G□	NRPS11-G□PN10	1A, 1.6A, 2A, 3.15A, 4A, 5A, 6A	SPDT		10
NRPF (Flat Type)	Non-sealed		NRPF11-□	NRPF11-□PN10	1A, 1.6A, 2A, 3.15A, 4A, 5A, 6A	SPDT		10
	Sealed (Tape-sealed)		NRPF11-G□	NRPF11-G□PN10	1A, 1.6A, 2A, 3.15A, 4A, 5A, 6A	SPDT		10

Note: Terminal © on 1NC contact type is provided for firm mounting on printed-circuit boards, without internal connections.

Ordering Information

When ordering, select appropriate circuit protectors in consideration of the soldering method and necessity of cleaning.

NRP Series PC Board Circuit Protectors

Selection Guide - Select appropriate circuit protectors (marked with X in the table below) according to your application.

Applications	Slim Type		Flat Type	
	Non-sealed	Sealed	Non-sealed	Sealed
	NRPS10-□ NRPS11-□	NRPS10-G □ NRPS11-G □	NRPF10-□ NRPF11-□	NRPF10-G □ NRPF11-G □
Manual soldering	X	X	X	X
Dip soldering	—	X	—	X
Cleaning after soldering	—	X	—	X
Automatic mounting on PC boards	X	X	—	—

Note: The sealed type is provided with epoxy-seal on the base and a tape seal on the actuator side. After cleaning, be sure to remove the tape seal.

When using flux, use rosin flux. Select the sealed type irrespective of cleaning necessity.

Specifications

Protection Method	Thermal tripping
Internal Circuit	Series Trip
No. of Poles	1 pole
Rated Voltage	250V AC (50/60Hz), 32V DC
Rated Current	1A, 1.6A, 2A, 3.15A, 4A, 5A, 6A
Rated Interrupting Capacity	1 to 4A: Rated current x 10 (resistive load) 5 and 6A: 250V AC/40A, 32V DC/40A (resistive load)
Minimum Applicable Load	5V AC/DC 100 mA (reference value)
Reference Temperature	25°C
Operating Temperature (Note)	-10 to +50°C (no freezing)
Operating Humidity	45 to 85% RH (no condensation)
Storage Ambient Temperature	-30°C to +70°C (no freezing)
Storage Ambient Humidity	45 to 85% RH (no condensation)
Vibration Resistance	100 m/sec ² (10 to 55 Hz)
Shock Resistance	Damage limits: 1000 m/s ² Operating extremes: 500 m/s ²
Life	200 operations (tripping at 200% the rated current)
Insulation Resistance	100 MΩ minimum (500V DC megger)
Dielectric Strength	1500V AC (50/60Hz), 1 minute (between terminals of the same pole when main contacts are open, and between live parts and ground)
Initial contact	Between terminals ① and ②: 200 mΩ maximum (5V DC • 1A) Between terminals ② and ③: 100 mΩ maximum (5V DC • 100mA)
Weight (Approx.)	2g

Note: The rated current is the value at the reference ambient temperature of 25°C, and varies with operating temperature. The rated current can be corrected according to the Temperature Correction Curve.

Time Delay Curves

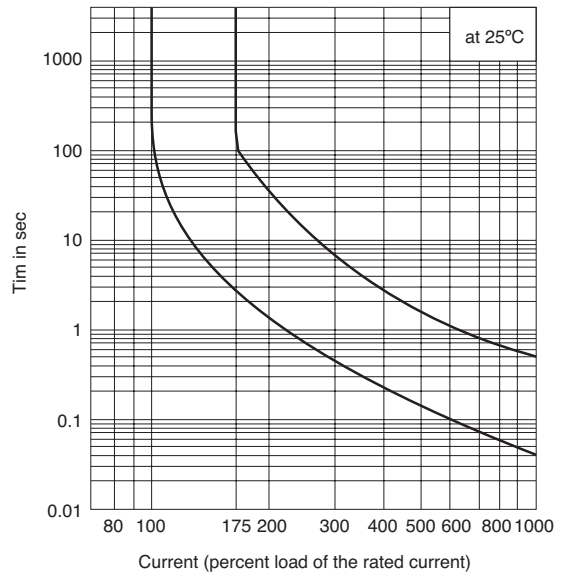

Temperature Correction Curve

The rated current is based on an ambient temperature of 25°C. Since a thermal tripping method is employed, the rated current should be corrected according to the ambient temperature with reference to the curve shown below.

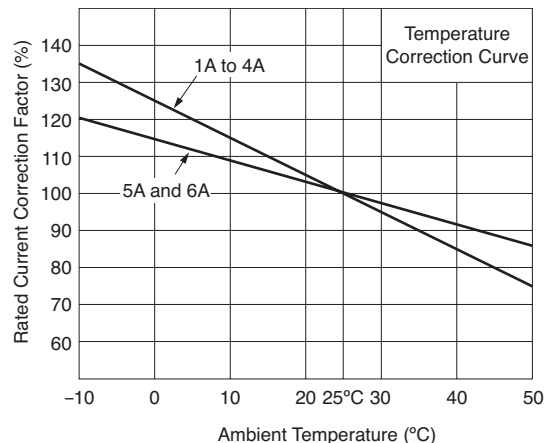

Overcurrent - Time Delay Characteristics (sec at 25°C)

Percent of Rated Current	100%	175%	200%	400%	600%	800%	1000%
Time Delay	No Trip	2.2-120	1.2-40	0.24-2.2	0.1-1	0.06-0.7	0.04-0.5

- Flush Silhouette
- Control Units
- Display Lights
- Display Units
- Safety Products
- Terminal Blocks
- Comm Terminals
- AS-Interface
- Relays & Timers
- Sockets
- Circuit Protectors**
- Power Supplies
- PLCs & SmartRelay
- Operator Interfaces
- Sensors
- Control Stations
- Explosion Protection
- References

NRP Series PC Board Circuit Protectors

Dimensions and PC Board Drilling Layout

Slim Type

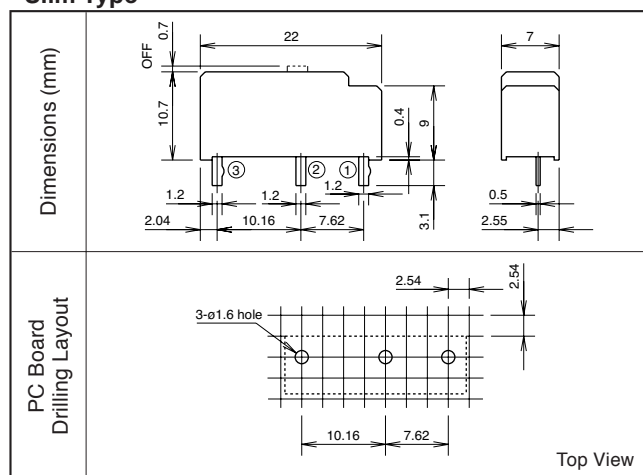

Flat Type

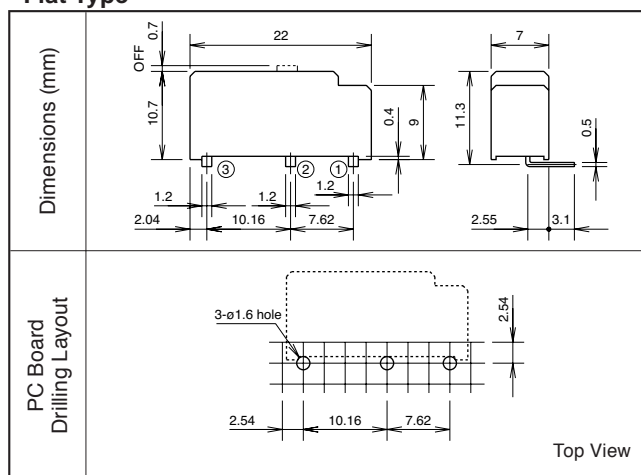

Dielectric Strength Test

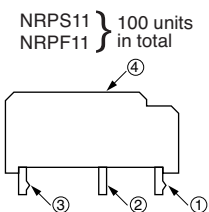

Short-circuit Test (AC)

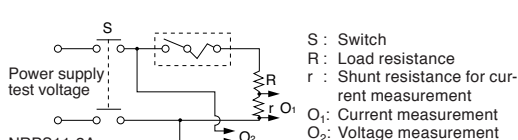

- Data**
- Power voltage: 220V AC, Frequency: 60Hz
 - Short-circuit current (effective value): 20A
 - Power factor: $\cos\phi = 1$ (4 cycles after power is applied)

Short-circuit Test (DC)

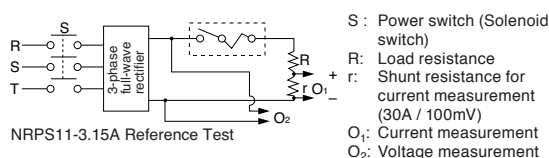

- Data**
- Power voltage: 32V DC
 - Short-circuit current: 31.5A

Item	1500V AC 1 minute	Critical Values		
		X	MIN	MAX
Between terminals (Open) ① - ② & ③	Normal	2800	1700	3400
Between terminals (Open) ② - ③ & ①	Normal	2740	2700	3400
Between housing and terminal ④ - ① & ② & ③	Normal	3600	3300	3800

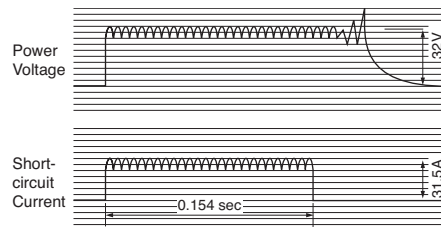
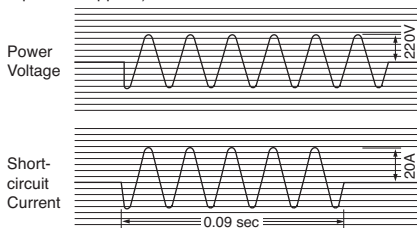

Applications of NRPS/NRPF Circuit Protectors

The NRPS/NRPF series circuit protectors are ideal for use on printed-circuit boards in small electric appliances to protect power transformers, rectifiers, small-motors, solenoid valves, and solenoids from overloads.

In addition to higher economic efficiency than that of fuses, the capability of over 200 repeated uses will find a wide range of applications in place of various fuses.

Applications Examples

Office Automation Equipment: Copiers, Shredders, Fax machines, Machine tools, Hydraulic devices, Robots, etc.

Measuring equipment: Testers, Oscilloscopes, etc.

Communication Equipment: Transmitter/Receiver, Telephone Exchanger

Power Supplies: Switching Power Supplies, Small Generators

Application Circuits Example

Transformer Protection Example

Transformer Primary Protection

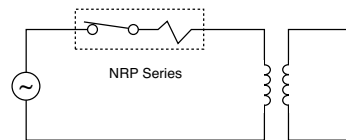

Transformer Secondary Protection

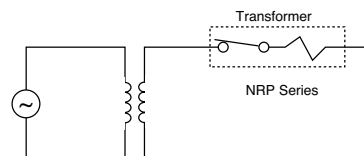

Rectifier Protection Example

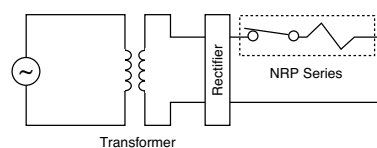

Motor Coil Protection

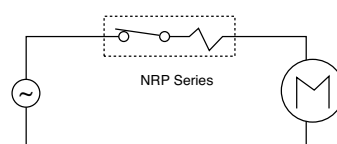

Safety Precautions

1. Soldering

- (1) • Soldering to the printed-circuit boards
Soldering should be done quickly referring to the conditions below. If the terminals are heated excessively, the bimetal may trip.
- Manual soldering
For manual soldering, complete soldering with a 60W soldering iron (soldering tip temp.: 350°C) quickly within 3 seconds. (When lead-free soldering is used, Sn-Ag-Cu is recommended.)
During soldering, keep the soldering iron away from the plastic housing of the circuit protector, and apply no external force by bending the terminal or pulling the wires.
(Check your actual soldering conditions before soldering.)
- Dip soldering
Dipping temperature: 260°C
Dipping duration: 5 seconds maximum
- (2) Do not solder the sealed type in a flow soldering bath. Since preheating process weakens the viscosity of the tape seal on the actuator due to the air expansion inside NRPS and the NRPF, air-tightness is possibly lowered.
- (3) For the non-sealed type, perform manual soldering. Do not use the water-soluble flux because it runs into the unit and it causes malfunctions.
- (4) Non-corrosive rosin flux is recommended because washing is not required.

2. Washing

- (1) When there is a possibility of washing, select the seal type.
- (2) Washing should be done at 60°C maximum within 30 seconds (and 50mm depth for full washing). Avoid steam washing. Use pure water as a cleaning solvent. When an organic solvent is used, use of alcohol is recommended. Before using other organic solvents, make sure that after actual washing, the tape seal is not removed and sealant or housing material is not affected.
- (3) The base of sealed type is provided with epoxy resin sealing and a tape seal covers the actuator. After cleaning, be sure to remove the tape from the actuator before use.

3. Notes for Bimetal

- (1) Storage temperature should not exceed 70°C. If storage temperature exceeds 70°C, the bimetal may trip.
- (2) Applied current should be under the rated current for the normal use. The rated current should be corrected according to the ambient temperature chart due to bimetal characteristics.
- (3) Since the NRPS and NRPF are designed for protection against overloads, they should be used within the rated interrupting capacity. An excessive overcurrent may affect the bimetal characteristics or damage the internal mechanism.
- (4) Note that the NRPS and NRPF do not respond to overcurrent for a period of few tens to few hundreds msec.

4. Manual OFF Mechanism

Manual OFF mechanism is performed by slightly pulling the white pin at the top of the unit with tweezers.

5. Other Notes

- (1) Make sure that no load (current) is applied before resetting manually turning the circuit OFF with actuator operation. In addition, avoid frequent opening and closing of the actuator at no load (current is not applied).
- (2) Turn power off and allow at least 60 seconds before rethrowing (at reference ambient temperature of 25°C). Reset the protector with no load. Do not press the actuator with something sharp, otherwise the internal part may be damaged.
- (3) Do not hold the actuator depressed while an overcurrent is present, because the overcurrent may damage the circuit protectors.

Flush Silhouette
Control Units
Display Lights
Display Units
Safety Products
Terminal Blocks
Comm Terminals
AS-Interface
Relays & Timers
Sockets
Circuit Protectors
Power Supplies
PLCs & SmartRelay
Operator Interfaces
Sensors
Control Stations
Explosion Protection
References

