

Marine Products
50 Ampere, 125 Volt Twist-Lock® Devices
 2 Pole 3 Wire
Ship-to-Shore Devices



Plugs and receptacles only.



50A 125V Ship-to-Shore Devices

Description	Catalog Numbers
Yellow 50 ft. (15.2m) vinyl jacketed shore power cable set. #6 AWG type STOW is completely factory pre-wired with molded-on devices. Connector end has threaded metallic sealing ring to make inlet/connector interface watertight. IP56 SUITABILITY (BOATSIDE).	HBL61CM53
Same as HBL61CM53 except with two high intensity LEDs.	HBL61CM53LED •
Same as HBL61CM53 except white.	HBL61CM53W
Same as HBL61CM53W except with two high intensity LEDs.	HBL61CM53WLED •
Same as HBL61CM53 except 25 ft. (7.6m) in length.	HBL61CM43
Same as HBL61CM43 except with two high intensity LEDs.	HBL61CM43LED •
Three conductor, #6 AWG type STOW, yellow PVC jacketed portable cord with jute fillers for added flexibility. Ideal for making cable sets, extension cords, and adapters will not mark boat's deck. 250 ft. (75.2m) lengths only.	YC306250
Nickel plated brass plug has heat resistant thermoset interior and combination metal and rubber cord grip, provides superior strain relief capability. Cord grip range is .44–1.14 in. (11.1–29.0). IP20 SUITABILITY.	HBL63CM61
Yellow Seal-Tite® cover for weatherproofing 50A plugs. IP55 SUITABILITY.	HBL77CM16+
White Seal-Tite cover for weatherproofing 50A plugs. IP55 SUITABILITY.	HBL77CM16W+
Single receptacle has a heat-resistant thermoset base. IP20 SUITABILITY.	HBL63CM70
Yellow Valox® lift cover for weatherproofing 50A receptacles. Meets requirements of the most stringent of UL's three listing categories for weatherproof plates. Stainless steel screws and a neoprene gasket included. For mounting to FS/FD type weatherproof boxes. IP44 SUITABILITY.	HBL77CM74WO
Same as HBL77CM74WO except gray in color. IP44 SUITABILITY.	HBL7774WO
Stainless steel wall plate for 50A receptacle.	SS750

Notes: + Boots are not UL listed.
 • Features and benefits on page W-14.



HBL61CM53
HBL61CM53W
HBL61CM43

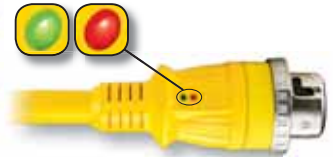

HBL63CM61



HBL77CM16



HBL63CM70



HBL77CM74WO



SS750

50A Molded Cable Sets

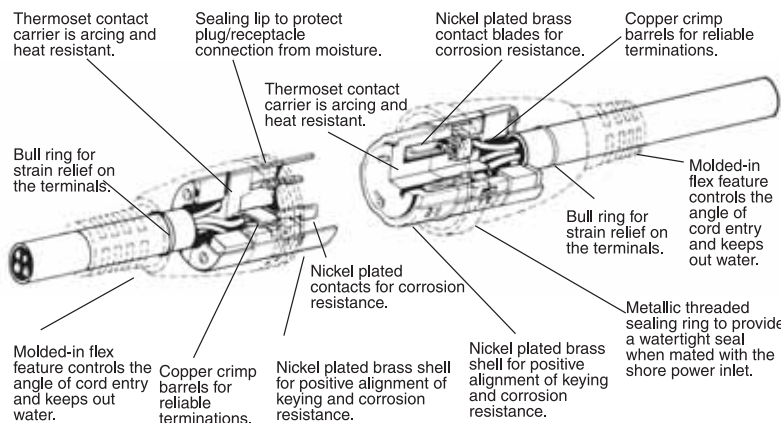

Valox® is a trademark of SABIC Innovative Plastics, acquired from General Electric Company.





Marine Products
50 Ampere, 125 Volt Twist-Lock® Devices
 2 Pole 3 Wire
Ship-to-Shore Devices



HBL503NM



HBL503RI



HBL503SS



HBL63CM60



HBL77CM15



HBL77CM17

50A 125V Ship-to-Shore Devices

Description

Stylized non-metallic shore power inlet has UV resistant white Centrex cover which makes unit weatherproof when completely closed. Interior has easy to wire terminals. Mounting holes are 2.38 in. (60.3) on centers and match existing mounting patterns. Mounting screws and gasket included.
IP56 SUITABILITY.

Catalog Numbers

HBL503NM

Stylized type 316 stainless steel shore power inlet has easy to use push-button latch that makes unit watertight when fully engaged. Interior has easy to wire terminals. Mounting holes are 2.38 in. (60.3) on centers and match existing mounting patterns. Mounting screws and gasket included.
IP56 SUITABILITY.

HBL503RI Δ

Traditional stainless steel shore power inlet has gasketed, self-closing cover so interior is shielded from the elements when not in use. Watertight when cover is securely fastened. Mounting holes are 2.38 in. (60.3) on centers, and rear portion has 2.17 in. (55.1) diameter. Mounting screws and gasket included.
IP56 SUITABILITY.

HBL503SS

Protective rear cover. Fits all inlets except HBL503SS. Secures to back of inlets with 3 screws which are provided.

SR3050**

Replacement interior for HBL503SS and 63CM72 shore power inlets.

CR16277

Nickel plated brass connector body has heat resistant thermoset interior and combination metal and rubber cord grip provides superior strain relief capability. Cord grip range is .44–1.14 in. (11.1–29.0). **IP20 SUITABILITY.**

HBL63CM60

Yellow Seal-Tite® cover for connector bodies when used with 50A shore power inlets. Threaded sealing ring makes connections watertight.
IP56 SUITABILITY.

HBL77CM15+

White Seal-Tite cover for connector bodies when used with 50A shore power inlets. Threaded sealing ring makes connections watertight.
IP56 SUITABILITY.

HBL77CM15W+

Nickel plated brass cord clamp assembly with clamp range of .44–1.14 in. (11.1–29.0) provides strain relief for terminations on shore power inlets.

HBL77CM67

Yellow Seal-Tite cover for weatherproofing 50A connector bodies on extension cords or adapters. **IP55 SUITABILITY.**

HBL77CM17+

Notes: + Boots are not UL listed.

** Not UL/CSA.

Δ To be discontinued when present stocks are exhausted.

50A Traditional Stainless Steel Inlets

Base and cover are #316 type stainless steel for strength and corrosion resistance.

Self-closing cover is friction tight to remain open while engaging cable set and shields the interior from the elements when the inlet is not in use.

Contact blades are nickel plated brass for corrosion resistance.

Neoprene gasket on underside of cover for sealing when the cover is closed.

Pressure screw terminals for secure terminations—clearly marked for easy identification.

Three screws "lock-in" the interior once it is in place.

Thermoset contact carrier is arcing and heat resistant.

Rear enclosure is nickel plated for corrosion resistance.

Threaded base for making a watertight seal. When in use, it mates to the threaded ring of the watertight cover on the connector body. When not in use, it mates to the threaded cover.

