

2-Pole 3-Wire Grounding 50 Amp 125V; 50 Amp 250V; 50 Amp 480V AC Locking Devices

Features - Specifications

PLUG, CONNECTOR

- Impact/chemical-resistant nylon housing
- Stainless steel plug shroud protects blades; helps prevent distortion, minimizing possibility of mismatching devices
- Box terminal with Allen-head terminal screws permits a high clamping pressure on conductors without damaging strands

- Accept #8 through #4 AWG
- Thermoplastic polyester interior provides impact strength and heat resistance
- Housing latch provides secure assembly
- Cord grip seal keeps out moisture and dust

PLUG, CONNECTOR, AND MALE BASE

- UL Listed File #E1381 – Guide #AXUT
- CSA Certified

RECEPTACLE

- Black melamine construction with heavy-duty steel shell
- Clamp-type terminals accept #10 through #6 AWG
- Mounts in F.S. and F.D. boxes
- UL Listed File #E2258 – Guide #RTRT
- CSA Certified



CS8269A



7774CR



CS8265



CS8264



CS8275A

2-POLE 3-WIRE 50 AMP 125V

CONFIG.	CATALOG NUMBER	CORD DIA.	DESCRIPTION
	CS6370A	—	Receptacle armored, grounded
	CS6361	.750 - 1.150 (19.1-29.2)	Nylon plug with cord grip
	CS6360	.750 - 1.150 (19.1-29.2)	Nylon connector with cord grip
	CS6377A	—	Male base, steel casing

2-POLE 3-WIRE 50 AMP 250V

CONFIG.	CATALOG NUMBER	CORD DIA.	DESCRIPTION
	CS8269A	—	Receptacle armored, grounded
	CS8265	.750 - 1.150 (19.1-29.2)	Nylon plug with cord grip
	CS8264	.750 - 1.150 (19.1-29.2)	Nylon connector with cord grip
	CS8275A	—	Male base, steel casing

2-POLE 3-WIRE 50 AMP 480V AC

CONFIG.	CATALOG NUMBER	CORD DIA.	DESCRIPTION
	CS8469A	—	Receptacle armored, grounded
	CS8465	.750 - 1.150 (19.1-29.2)	Nylon plug with cord grip
	CS8464	.750 - 1.150 (19.1-29.2)	Nylon connector with cord grip
	CS8475A	—	Male base, steel casing

WEATHER PROTECTIVE PLATE ①

CATALOG NUMBER	DESCRIPTION
7774CR	Plate, weather protective, yellow fiberglass, with lift cover

WEATHER PROTECTIVE BOOTS ②

CATALOG NUMBER	DESCRIPTION
7716B	Black elastomer weather protective boot for plugs when used in a cord set, and connectors when used with flanged inlets
7717B	Black elastomer weather protective boot for connectors when used in a cord set

PRODUCT DIMENSIONS – () Indicates mm dimensions

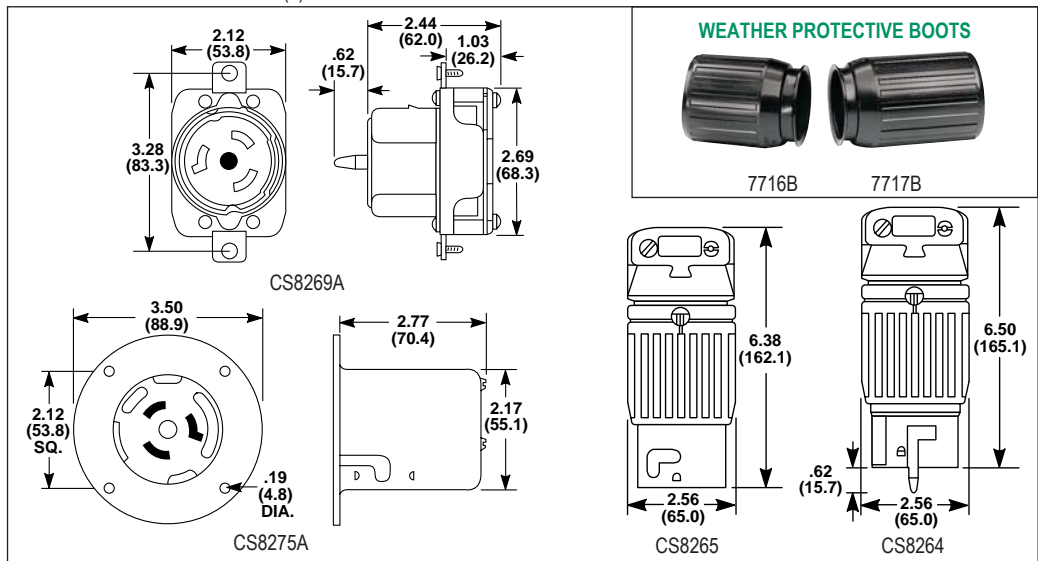

① See page M-1 for information on plates.

② See page I-17 for more information on boots.

Specifications are subject to change without notice.