

RIGID AND IMC FITTINGS

STEEL - LOCKNUTS

Application

- For use in dry locations on threaded Rigid/IMC conduit to secure conduit to a box or enclosure

Product Features

- All steel construction insures mechanical protection
- Zinc electro plated for corrosion protection



Non-UL Locknuts
Steel

RACO COMMERCIAL FITTINGS

ORDERING INFORMATION - DIMENSIONS

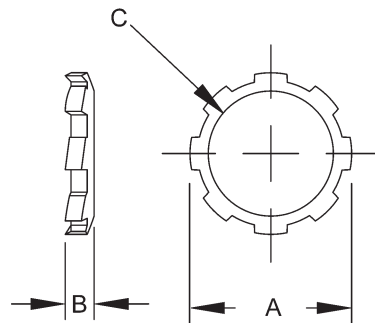

A = O.D.
B = Thickness
C = Thread size

NON - UL LOCKNUTS - STEEL				
CATALOG NUMBER	TRADE SIZE	UNIT CTN. QTY.	SHIP CTN. QTY.	UPC BAR CODE
1192	1/2"	100	1000	—
1193	3/4"	100	1000	—
1194	1"	—	100	—
1195	1-1/4"	—	50	—
1196	1-1/2"	—	50	—
1198	2"	—	50	—
1197	2-1/2"	—	30	—
1199	3"	—	25	—
1200	3-1/2"	—	15	—
1201	4"	—	10	—
1219	5"	—	8	—
1220	6"	—	8	—

DIMENSIONS			
CATALOG NUMBER	A	B	C THD. SPEC.
1192	1-1/8"	9/64"	1/2"-14 NPT
1193	1-25/64"	5/32"	3/4"-14 NPT
1194	1-23/32"	3/16"	1"-11-1/2 NPT
1195	2-1/16"	13/64"	1-1/4"-11-1/2 NPT
1196	2-3/8"	13/64"	1-1/2"-11-1/2 NPT
1198	2-57/64"	13/64"	2"-11-1/2 NPT
1197	3-15/32"	15/64"	2-1/2"- 8 NPT
1199	4-3/16"	15/64"	3"- 8 NPT
1200	4-11/16"	15/64"	3-1/2"- 8 NPT
1201	5-9/32"	15/64"	4"- 8 NPT
1219	6-1/2"	6-1/4"	5"- 8 NPT
1220	7-55/64"	7-19/64"	6"- 8 NPT

