

Enclosures can be Factory Modified ( Milling, Drilling, Printing etc.)  
 Contact Factory [mjm@hammondmfg.com](mailto:mjm@hammondmfg.com) for quotes  
 Solid models of this enclosure available in STEP or IGES.  
 (Part number and text placement/orientation on our products are subject to change,  
 we do not recommend using them as a locating reference for modification purposes)

**NOTE**  
 Purchased assembly includes box, lid and 4 cover screws.  
 Box and lid are made from Diecast Aluminum Alloy.  
 Silicone Gasket supplied with liquid resistant enclosure.  
 Bottom Flange is Welded.

**Recommended Torque : 50-55 cN.m [71-78 ozf.in]**  
**Recommended Torque with Gasket : 25-30 cN.m [36-43 ozf.in]**

**PART NUMBERS**

1590GF Enclosure	
Natural Finish Enclosure	1590GF
Black Textured Enclosure	1590GFBK
1590GF Liquid Resistant Enclosure (Silicone Gasket)	
Natural Finish Enclosure	1590WGF
Black Textured Enclosure	1590WGFBK

**ACCESSORIES**

Liquid Resistant Cover Screws	
Stainless Steel Cover Screws (Pkg 100) [6-32 x 1/2" With O-Ring]	1590WMS100
Black Stainless Steel Cover Screws (Pkg 100) [6-32 x 1/2" With O-Ring]	1590WMS100BK
Standard Cover Screws	
Plated Cover Screws (Pkg 100) [6-32 x 1/2"]	1590MS100
Black Cover Screws (Pkg 100) [6-32 x 1/2"]	1590MS100BK

**HAMMOND MANUFACTURING®**  
**1590GF**  
[www.hammondmfg.com](http://www.hammondmfg.com)

Dimensions:  
 mm  
 [inches]

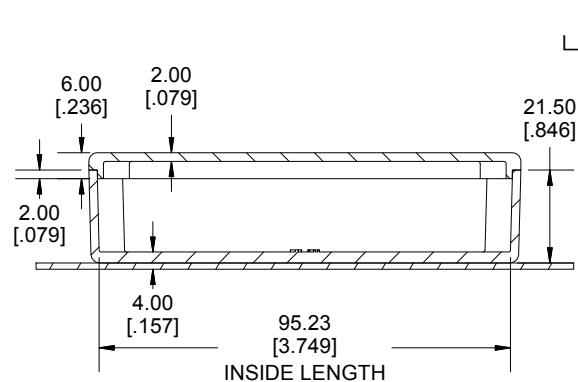

**SECTION B-B  
 SIDE VIEW**

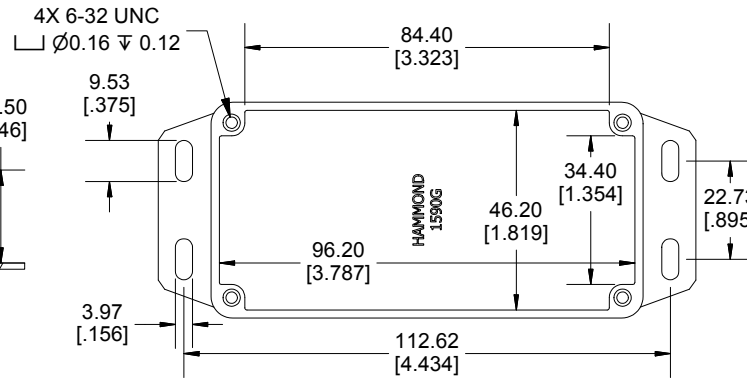

**INSIDE BOX**

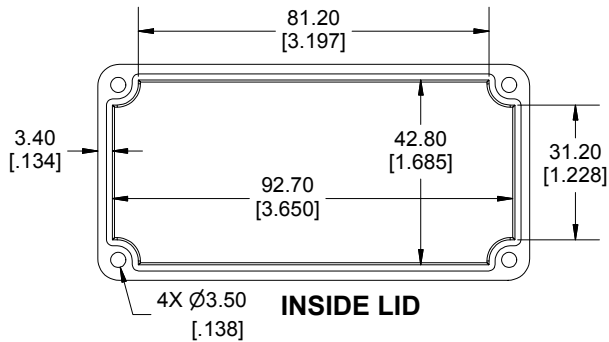

**INSIDE LID**

