

TOP VIEW

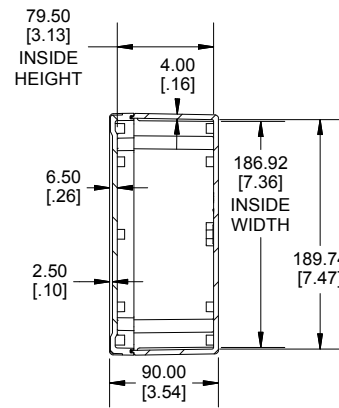

SECTION A-A
END VIEW

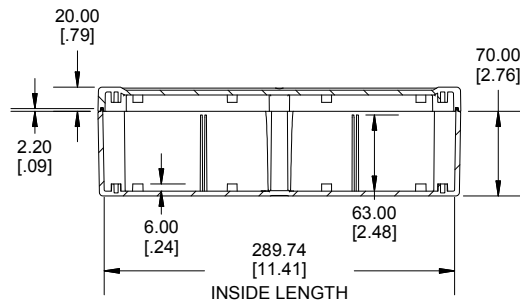
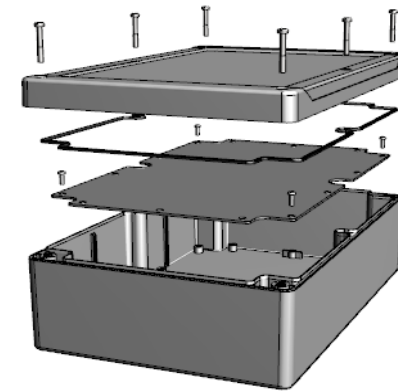

SECTION B-B
SIDE VIEW

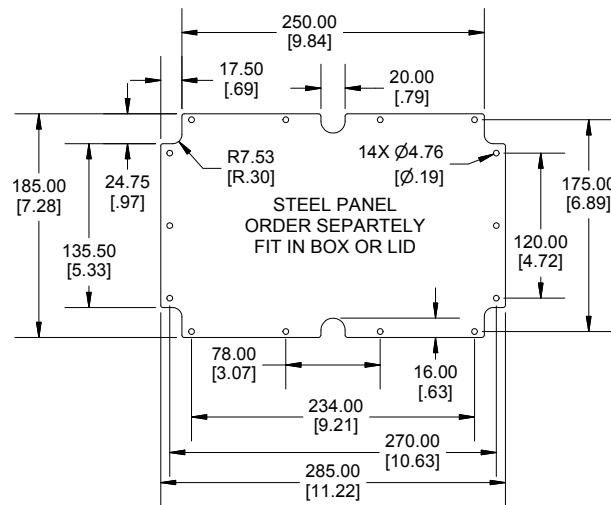

STEEL PANEL
ORDER SEPARATELY
FIT IN BOX OR LID



Enclosures can be Factory Modified (Milling, Drilling, Printing etc.)
Contact Factory mjm@hammondmfg.com for quotes
Solid models of this enclosure available in STEP or IGES.
(Part number and text placement/orientation on our products are subject to change, we do not recommend using them as a locating reference for modification purposes)

NOTE

6 cover screws, and preformed silicone gasket.
General Purpose ABS version is not UL approved. (Matl UL94 - HB)
Polycarbonate version is UL 508A approved. (Matl UL94 - 5VA @ 3mm)

Recommended Cover screw torque -- 43-57 ozf-in (30-40 cN-m)

DETAIL C

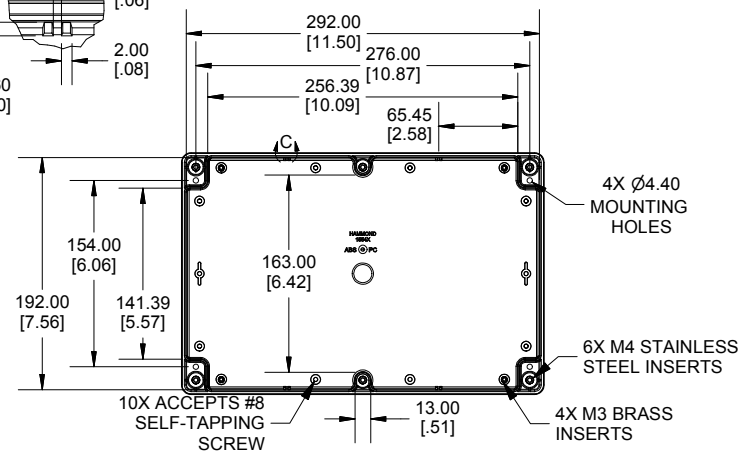
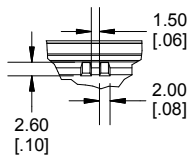

INSIDE BOX

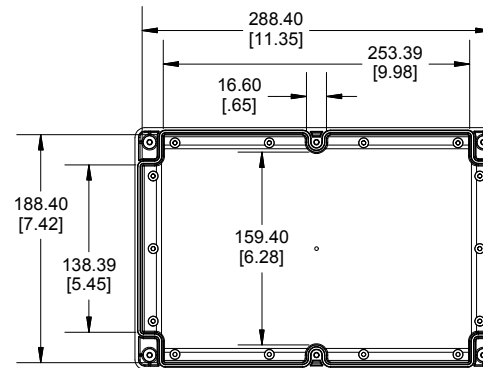

INSIDE LID

Dimensions:
mm
[inches]

1555X	
1555X Regular Enclosure	
General Purpose ABS RAL-7035	1555XGY
Polycarbonate RAL-7035	1555X2GY
ACCESSORIES	
Steel Inner Panels	1554XPL
Steel Panel / P.C. Board Screw [M3-0.5 x 8mm Plated] (Pkg 100)	1591MM100
Steel Panel / P.C. Board Self Tapping Screw [#8 X 5/16" (6.4mm)]	SC554-100
Stainless Steel Cover Screws [M4-0.7 X 25mm] (Pkg 50)	SC583-50
Silicone Pre-formed Gasket Black (Pkg 2)	1554XGASKET

