

AS85049/60-1 and MS3158 Straight Shrink Boot Adapter

CONNECTOR DESIGNATOR:

A

AS50151 Series AS34001
MIL-DTL-26482 Series II
AS81703 Series III
MIL-DTL-83723 Series I & III
40M39569, DEF 5326-3
EN 2997, EN 3646
ESC 10, ESC 11, LN 29504
NFC93422 Series HE302
PAN 6432-1, PAN 6432-2
PATT 602

Basic Part Number
Shell Size
M85049/60-1 - W 22
Finish

A = Anodize Black
N = Electroless Nickel
W = 1,000 Hr. Cadmium Olive Drab

Superseded Part Number

Basic Part Number
Shell Size
MS3158 - 22 C
Finish

A = 1,000 Hr. Cadmium Olive Drab
C = Cadmium Olive Drab
N = Electroless Nickel

APPLICATION NOTES

- For complete dimensions see the applicable Military Specification.
- Metric dimensions (mm) are in parentheses.

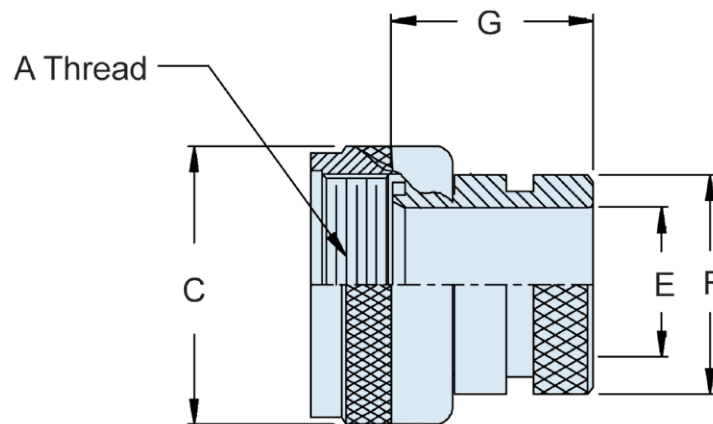
TABLE I: Shell Size, Thread and Dimensions

Shell Size	A Thread Class 2B	C Dia Max +.000 (0.0) -.045 (1.14)	E Min Dia	F Dia +.000 (0.0) -.020 (0.5)	G Max
3	.562 - 24 UNEF	.670 (17.0)	.250 (6.4)	.533 (13.5)	.832 (21.1)
8	.500 - 20 UNF	.620 (15.7)	.250 (6.4)	.533 (13.5)	.832 (21.1)
10	.625 - 24 UNEF	.740 (18.8)	.355 (9.0)	.605 (15.4)	.832 (21.1)
12	.750 - 20 UNEF	.860 (21.8)	.491 (12.5)	.774 (19.7)	.832 (21.1)
14	.875 - 20 UNEF	.980 (24.9)	.565 (14.4)	.838 (21.3)	.832 (21.1)
16	1.000 - 20 UNEF	1.110 (28.2)	.690 (17.5)	.963 (24.5)	.832 (21.1)
18	1.062 - 18 UNEF	1.220 (31.0)	.769 (19.5)	1.042 (26.5)	.832 (21.1)
20	1.188 - 18 UNEF	1.350 (34.3)	.894 (22.7)	1.217 (30.9)	.832 (21.1)
22	1.313 - 18 UNEF	1.470 (37.3)	1.019 (25.9)	1.355 (34.4)	.832 (21.1)
24	1.438 - 18 UNEF	1.590 (40.4)	1.134 (28.8)	1.443 (36.7)	.832 (21.1)
28	1.750 - 18 UNS	1.970 (50.0)	1.369 (34.8)	1.709 (43.4)	.994 (25.3)
32	2.000 - 18 UNS	2.220 (56.4)	1.615 (41.0)	1.919 (48.7)	.994 (25.3)
36	2.250 - 16 UN	2.470 (62.7)	1.830 (46.5)	2.169 (55.1)	.994 (25.3)
40	2.500 - 16 UN	2.720 (69.1)	2.045 (51.9)	2.402 (61.0)	.994 (25.3)
44	2.750 - 16 UN	2.970 (75.4)	2.300 (58.4)	2.657 (67.5)	.994 (25.3)
48	3.000 - 16 UN	3.220 (81.8)	2.550 (64.8)	2.907 (73.8)	.994 (25.3)
61	1.500 - 18 UNEF	1.650 (41.9)	1.174 (29.8)	1.529 (38.8)	.832 (21.1)