

International Fuses

A world of circuit protection solutions — in your backyard



Your problem:

For most of our customers, globalization isn't just a buzzword it's a reality with very tangible challenges for those in charge of purchasing, inventory, installations, repairs, and other operational duties. And that's true whether you're building, operating, or maintaining overseas manufacturing centers. Exporting equipment designed to be acceptable to overseas inspection authorities and electrical professionals. Or ensuring imported equipment is optimally installed and maintained.

Our solution: Mersen offers you the benefits of a truly global supplier. From the one-stop shopping advantages of our complete line of European and North American fuses, holders, and accessories. To our pursuit of other international technologies. To our definitive understanding of international circuit protection standards such as those of the IEC and CENELEC.

Want more information fast? For more technical or application-specific information, please call our International Fuse experts, at 978-462-6662; 416-252-9371 in Canada; or visit our website at ep.mersen.com.

F International Fuses

EURO/IEC Fuses

- gl-gG, aMF2
- D0 type (NEOZED)F7
- D typeF11
- NH Dimension / gl-gG, aMF15

Canadian Fuses

- Class CF20
- Class H NRN/NRSF22
- Class H CRN/CRSF23

gl-gG, aM Cylindrical Fuse-Links

Domestic and industrial cylindrical fuse-links

Mersen gl-gG and aM fuse-links cover a wide range of physical sizes and ampere ratings for 400, 500, and 690 volts AC. gl-gG and aM fuse-links are for industrial applications. Most ratings are available with an optional indicator. All industrial fuse-links have the option of a built-in striker. All cylindrical fuse-links have ceramic bodies and silver-plated ferrules.

gl-gG

Full Range Protection

- 4 physical sizes from 8 x 31mm to 22 x 58 mm
- 400, 500 and 690 Volt ratings - 0.5A through 125A
- Most ratings available with indicator
- Meet IEC, NFC and UNE standards
- Approved by Lloyds Register of Shipping and Bureau Veritas

aM

Short Circuit Protection

- 4 physical sizes from 8 x 31mm to 22 x 58mm
- 400, 500 and 690 Volt ratings - 16A through 125A
- Most ratings available with indicator
- Meet IEC, NFC and UNE standards
- Approved by Lloyds Register of Shipping and Bureau Veritas

gl-gG

Full Range Protection Fuse-links with Striker

- 2 sizes-14 x 51mm and 22 x 58mm
- 400, 500 and 690 Volt ratings - 4A through 125A
- All ratings include striker
- Meet IEC, NFC and UNE standards
- Approved by Lloyds Register of Shipping and Bureau Veritas

aM

Short Circuit Protection Fuse-links with Striker

- 2 sizes - 14 x 51mm and 22 x 58mm
- 400, 500 and 690 Volt ratings - 2A through 125A
- All ratings include striker
- Meet IEC, NFC and UNE standards
- Approved by Lloyds Register of Shipping and Bureau Veritas



gl-gG Cylindrical Fuse-Links

Catalog Numbers, Ratings – gl-gG (Optional Blown-Fuse Indicator)

Size (mm x mm)	Rated In Current (A)	Rated Voltage	w/o indicator			w Indicator			Interrupting Rating (A)	Standard Pack/Ctn				
			Catalog No.	New Ref. No.	New Cat. No.	Catalog No.	New Ref. No.	New Cat. No.						
8x31	0.5	400V	15009-G	P218191	FR8GG40V0.5				20,000	10/100				
	1		15011-G	C218709	FR8GG40V1									
	2		15013-G	Q219227	FR8GG40V2	15213-G	B222204	FR8GG40V2I						
	4		15019-G	W222958	FR8GG40V4	15219-G	X222959	FR8GG40V4I						
	6		15023-G	A211025	FR8GG40V6	15223-G	V201291	FR8GG40V6I						
	8		15027-G	B213096	FR8GG40V8	15227-G	B211026	FR8GG40V8I						
	10		15031-G	A214613	FR8GG40V10	15231-G	A212060	FR8GG40V10I						
	12		15033-G	R216146	FR8GG40V12	15233-G	C213097	FR8GG40V12I						
	16		15035-G	P216650	FR8GG40V16	15235-G	Y214105	FR8GG40V16I						
	20		15037-G	F217677	FR8GG40V20	15237-G	J215127	FR8GG40V20I						
25	15039-G	D218710	FR8GG40V25	15239-G	S216147	FR8GG40V25I								
10x38	0.5	500V	16009-G	C211027	FR10GG50V0.5				120,000	10/100				
	1		16011-G	B212061	FR10GG50V1									
	2		16013-G	D213098	FR10GG50V2	16213-G	S216653	FR10GG50V2I						
	4		16019-G	X213598	FR10GG50V4	16219-G	E217170	FR10GG50V4I						
	6		16023-G	K215128	FR10GG50V6	16223-G	T218195	FR10GG50V6I						
	8		16027-G	D217169	FR10GG50V8	16227-G	V219231	FR10GG50V8I						
	10		16031-G	S218194	FR10GG50V10	16231-G	E222207	FR10GG50V10I						
	12		16033-G	W219761	FR10GG50V12	16233-G	H200751	FR10GG50V12I						
	16		16035-G	G200750	FR10GG50V16	16235-G	H201809	FR10GG50V16I						
	20		16037-G	D211028	FR10GG50V20	16237-G	X211551	FR10GG50V20I						
	25		16039-G	E213099	FR10GG50V25	16239-G	W212585	FR10GG50V25I						
	32		16043-G	A214107	FR10GG40V32	16243-G	Z213600	FR10GG40V32I						
	14x51		1	690V	17011-G	K218716	FR14GG69V1						80,000	10/50
			2		17013-G	Y219234	FR14GG69V2							
4		17019-G	A219765		FR14GG69V4									
6		17023-G	H222210		FR14GG69V6									
8		17027-G	D222965		FR14GG69V8									
10		17031-G	L200754		FR14GG69V10									
12		17033-G	L201812		FR14GG69V12									
16		17035-G	A211554		FR14GG69V16									
20		17037-G	Z212588		FR14GG69V20									
25		17039-G	C213603		FR14GG69V25									
32		17043-G	W216656		FR14GG50V32									
40		17047-G	X218198		FR14GG50V40									
50		17051-G	Z219235		FR14GG50V50									
22x58		2	690V		18013-G	F219241	FR22GG69V2				80,000	10/50		
	4	18019-G		H219772	FR22GG69V4									
	6	18023-G		P222216	FR22GG69V6									
	8	18027-G		L222972	FR22GG69V8									
	10	18031-G		T200761	FR22GG69V10									
	12	18033-G		J201304	FR22GG69V12									
	16	18035-G		S201818	FR22GG69V16									
	20	18037-G		P211038	FR22GG69V20									
	25	18039-G		N212072	FR22GG69V25									
	32	18043-G		F212594	FR22GG69V32									
	40	18047-G		J213609	FR22GG69V40									
	50	18051-G		P214626	FR22GG69V50									
	63	18055-G		Y215646	FR22GG69V63									
	80	18059-G		Q217180	FR22GG69V80									
	100	18063-G		E218205	FR22GG50V100									
	125	18065-G		J219773	FR22GG50V125									

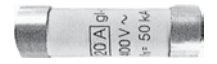

FR8GG40V20



FR10GG50V20



FR14GG69V25



FR22GG69V80

Dimensions (mm)

Fuse Size	A	B	C
8 x 31	8.5	31.5	6.3
10 x 38	10.3	38	10.5
14 x 51	14.3	51	13.8
22 x 58	22.2	58	16.2

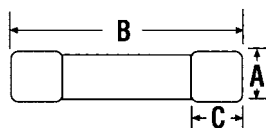

gl-gG Cylindrical Fuse-Links

Catalog Numbers, Ratings – gl-gG with Striker

Size (mm x mm)	Rated In Current (A)	Rated Voltage	Catalog Number	New Reference No.	New Catalog No.	Interrupting Rating (A)	Standard Pack/Ctn
14x51	2	500V	17413-G	J211033	FR14GG50V2P	120,000	10/50
	4		17419-G	H212067	FR14GG50V4P		
	6		17423-G	G214113	FR14GG50V6P		
	8		17427-G	R215134	FR14GG50V8P		
	10		17431-G	Z216153	FR14GG50V10P		
	12		17433-G	L217176	FR14GG50V12P		
	16		17435-G	Z218200	FR14GG50V16P		
	20		17437-G	B219237	FR14GG50V20P		
	25		17439-G	L222213	FR14GG50V25P		
	32		17443-G	P200757	FR14GG50V32P		
	40		17447-G	P201815	FR14GG50V40P		
	50		17451-G	D211557	FR14GG50V50P		
22x58	4	690V	18419-G	R214628	FR22GG69V4P	80,000	10x50
	6		18423-G	A215648	FR22GG69V6P		
	8		18427-G	F216665	FR22GG69V8P		
	10		18431-G	W217691	FR22GG69V10P		
	12		18433-G	W218726	FR22GG69V12P		
	16		18435-G	L219775	FR22GG69V16P		
	20		18437-G	P222975	FR22GG69V20P		
	25		18439-G	M201307	FR22GG69V25P		
	32		18443-G	S211041	FR22GG69V32P		
	40		18447-G	R212075	FR22GG69V40P		
	50		18451-G	M213612	FR22GG69V50P		
	63		18455-G	S214629	FR22GG50V63P		
	80	18459-G	F216159	FR22GG50V80P			
	100	18463-G	T217183	FR22GG50V100P			
	125	18465-G	H218208	FR22GG50V125P			



FR14GG50V40P



FR22GG69V40P

Striker



Before



After

Fuse Construction

- 1 Ceramic body
- 2 Sand
- 3 Indicator contact
- 4 Lower contact
- 5 Contact ring
- 6 Melting element
- 7 Indicator

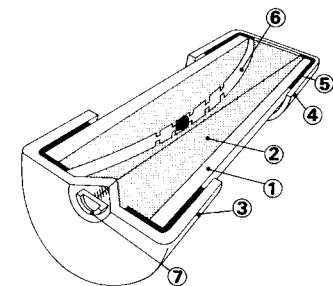

Dimensions (mm)

Fuse Size	A	B	C	D	E
14 x 51	14.3	51	13.8	7.5	3.8
22 x 58	22.2	58	16.2	7.5	3.8

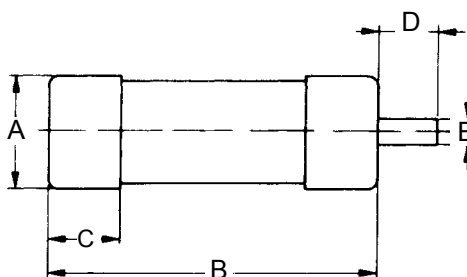

aM Cylindrical Fuse-Links

Catalog Numbers, Ratings – aM (Optional Blown-Fuse Indicator)

Size (mm x mm)	Rated In Current (A)	Rated Voltage	w/o Indicator			w Indicator			Interrupting Rating (A)	Standard Pack/Ctn
			Catalog No.	New Ref. No.	New Cat. No.	Catalog No.	New Ref. No.	New Cat. No.		
8x31	1	400V	15511-G	C217168	FR8AM40V1				20,000	10/100
	2		15513-G	R218193	FR8AM40V2					
	4		15519-G	S219229	FR8AM40V4					
	6		15523-G	C222205	FR8AM40V6					
	8		15527-G	F200749	FR8AM40V8					
	10		15531-G	W201292	FR8AM40V10					
10x38	0.16	500V	16503-G	E214617	FR10AM50V0.16				120,000	10/100
	0.25		16507-G	M215130	FR10AM50V0.25					
	0.5		16509-G	W216150	FR10AM50V0.5					
	1	16511-G	F217171	FR10AM50V1	16711-G	X219233	FR10AM50V1I			
	2	16513-G	H218714	FR10AM50V2	16713-G	G222209	FR10AM50V2I			
	4	16519-G	W219232	FR10AM50V4	16719-G	K200753	FR10AM50V4I			
	6	16523-G	F222208	FR10AM50V6	16723-G	K201811	FR10AM50V6I			
	8	16527-G	Z201295	FR10AM50V8	16727-G	Z211553	FR10AM50V8I			
	10	16531-G	Y211552	FR10AM50V10	16731-G	H213102	FR10AM50V10I			
	12	16533-G	A213601	FR10AM50V12	16733-G	D214110	FR10AM50V12I			
	16	16535-G	F214618	FR10AM50V16	16735-G	P215132	FR10AM50V16I			
	20	16537-G	X216151	FR10AM50V20	16737-G	V216655	FR10AM50V20I			
	25	16539-G	G217172	FR10AM40V25	16739-G	L217682	FR10AM40V25I			
	32	16543-G	J218715	FR10AM40V32						
	14x51	0.25	690V	17507-G	B212590	FR14AM69V0.25				80,000
0.5		17509-G		L213105	FR14AM69V0.5					
1		17511-G		E213605	FR14AM69V1					
2		17513-G	H214114	FR14AM69V2						
4		17519-G	K214622	FR14AM69V4						
6		17523-G	S215135	FR14AM69V6						
8		17527-G	T215642	FR14AM69V8						
10		17531-G	Z216659	FR14AM69V10						
12		17533-G	M217177	FR14AM69V12						
16		17535-G	Q217686	FR14AM69V16						
20		17537-G	P218720	FR14AM69V20						
25		17539-G	E219769	FR14AM69V25						
32		17543-G	M222214	FR14AM50V32						
40		17547-G	Q200758	FR14AM50V40						
45		17549-G	L211035	FR14AM50V45						
50	17551-G	E211558	FR14AM50V50							
22x58	4	690V	18519-G	Q222976	FR22AM69V4				80,000	10/50
	6		18523-G	Y200765	FR22AM69V6					
	8		18527-G	N201308	FR22AM69V8					
	10	18531-G	X201822	FR22AM69V10						
	12	18533-G	T211042	FR22AM69V12						
	16	18535-G	M211565	FR22AM69V16						
	20	18537-G	S212076	FR22AM69V20						
	25	18539-G	J212597	FR22AM69V25						
	32	18543-G	V213113	FR22AM69V32						
	40	18547-G	N213613	FR22AM69V40						
	50	18551-G	R214122	FR22AM69V50						
	63	18555-G	C215650	FR22AM69V63						
	80	18559-G	H216667	FR22AM69V80						
	100	18563-G	Y217693	FR22AM50V100						
	125	18565-G	J218209	FR22AM50V125						



FR14AM69V16



FR22AM69V63

Dimensions (mm)

Fuse Size	A	B	C
8 x 31	8.5	31.5	6.3
10 x 38	10.3	38	10.5
14 x 51	14.3	51	13.8
22 x 58	22.2	58	16.2

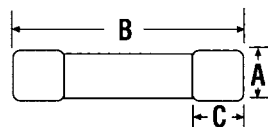

aM Cylindrical Fuse-Links

Catalog Numbers, Ratings – aM with Striker

Size (mm x mm)	Rated In Current (A)	Rated Voltage	Catalog Number	New Ref. No.	New Cat. No.	Interrupting Rating (A)	Standard Pack/Ctn
14 X 51	1	500V	17911-G	W215644	FR14AM50V1P	120,000	10/50
	2		17913-G	B216661	FR14AM50V2P		
	4		17919-G	C218203	FR14AM50V4P		
	6		17923-G	E219240	FR14AM50V6P		
	8		17927-G	N222215	FR14AM50V8P		
	10		17931-G	S200760	FR14AM50V10P		
	12		17933-G	R201817	FR14AM50V12P		
	16		17935-G	G211560	FR14AM50V16P		
	20		17937-G	E212593	FR14AM50V20P		
	25		17939-G	H213608	FR14AM50V25P		
	32		17943-G	N214625	FR14AM50V32P		
	40		17947-G	X215645	FR14AM50V40P		
	45		17949-G	C216662	FR14AM50V45P		
	50		17951-G	D218204	FR14AM50V50P		
22 X 58	4	690V	18919-G	A217695	FR22AM69V4P	80,000	10/50
	6		18923-G	Y218728	FR22AM69V6P		
	8		18927-G	Q219779	FR22AM69V8P		
	10		18931-G	S222978	FR22AM69V10P		
	12		18933-G	R201311	FR22AM69V12P		
	16		18935-G	W211044	FR22AM69V16P		
	20		18937-G	W212079	FR22AM69V20P		
	25		18939-G	Q213615	FR22AM69V25P		
	32		18943-G	X214633	FR22AM69V32P		
	40		18947-G	F215653	FR22AM69V40P		
	50	18951-G	K216669	FR22AM69V50P			
	63	500V	18955-G	B217696	FR22AM50V63P	120,000	
	80		18959-G	Z218729	FR22AM50V80P		
	100		18963-G	T222979	FR22AM50V100P		
	125		18965-G	S201312	FR22AM50V125P		

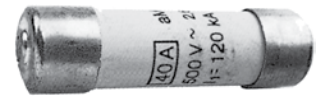

FR14AM50V40P



FR22AM69V50P

Striker



BEFORE

AFTER

Dimensions (mm)

Fuse Size	A	B	C	D	E
14 x 51	14.3	51	13.8	7.5	3.8
22 x 58	22.2	58	16.2	7.5	3.8

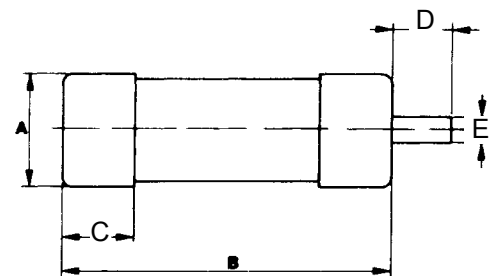

DO Type (NEOZED)

400 Volt DO Type NEOZED fuse-links, screw caps and fuse bases

Mersen DO fuse-links, also called Neozed type, are 400 Volts AC rated with 100kA interrupting rating. They have 3 physical sizes, DO1, DO2, and DO3 and fit into special screw caps. All fuse-links have blown-fuse indicators which are visible through the screw cap when mounted. Screw caps fit onto single and three-pole bases which are screw or DIN rail mounted. All accessories such as covers and gauge rings are described.

DO Type NEOZED Fuses, 400VAC, 250VDC gG

Size	Rated Current	Catalog Number	Reference Number	New Catalog Number	Gauge Color	Standard Pack/Ctn.
DO1	2	1700.002-L	T214676	D01GG40V2	Pink	50
	4	1700.004-L	W200809	D01GG40V4	Brown	
	6	1700.006-L	B215695	D01GG40V6	Green	
	10	1700.010-L	W211090	D01GG40V10	Red	
	16	1700.016-L	R223023	D01GG40V16	Grey	
DO2	20	1701.020-L	B217742	D02GG40V20	Blue	50
	25	1701.025-L	W213160	D02GG40V25	Yellow	
	35	1701.035-L	R219826	D02GG40V35	Black	
	50	1701.050-L	D215191	D02GG40V50	White	
	63	1701.063-L	C201873	D02GG40V63	Copper	
DO3	80	1702.080-L	L216716	D03GG40V80	Silver	10
	100	1702.100-L	N212647	D03GG40V100	Red	

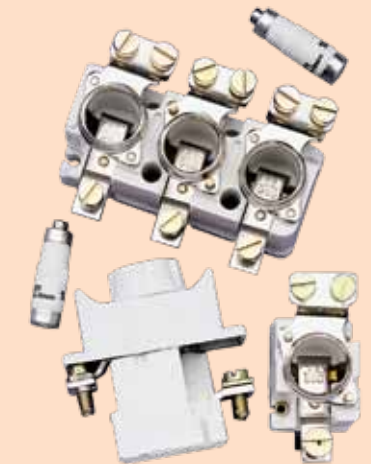

Ratings:

Volts : 400VAC (gG)
 : 250VDC (gG)
 : 400VAC/VDC (gM)
Amps : 2 to 100A
I.R. : 100kA I.R.

DO Type NEOZED Fuses, 400VAC/VDC, aM

DO2	20	1701.0205-L	H211607	D02AM44V20	Blue	10
	25	1701.0255-L	F212640	D02AM44V25	Yellow	
	35	1701.0355-L	J213655	D02AM44V35	Black	

Dimensions (mm)

	DO1	DO2	DO3
A	11	15	22
B	36	36	43
D	E 14	E 18	M 30x2

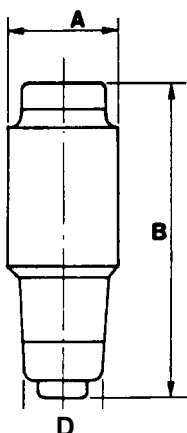

Fuse Construction

- 1 Ceramic body
- 2 Sand
- 3 Upper contact
- 4 Contact top
- 5 Lower contact
- 6 Melting element
- 7 Indicator

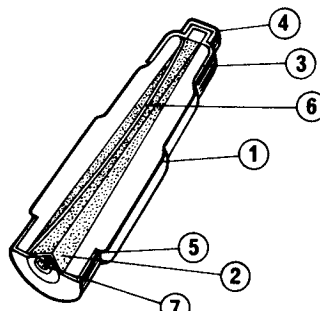

Approvals:

- Meet IEC, VDE standards:
 IEC 269-3, 3A
 VDE 0636
 DEN 60269-1
 02-1

DO Type (NEOZED)

DO NEOZED Screw Caps - Plastic, 400VAC/VDC

Size	Rated Current	Cap Thread	Catalog Number	Reference Number	New Catalog No.	Standard Pack/Ctn.
With Test Hole						
DO1	16	E 14	1714.0002-L	E212501	01714.000200	20
DO2	63	E 18	1715.0002-L	P211981	01715.000200	
With Sealable Hole and Testing Hole						
DO1	16	E 14	11714.00022-L	R214536	11714.000220	20
DO2	63	E 18	11715.00022-L	S214537	11715.000220	
Without Test Hole						
DO2	63	E 18	1715-L	L206435	01715.000000	20



Screw Cap - Porcelain, 400VAC/VDC

Size	Rated Current	Cap Thread	Catalog Number	Reference Number	New Catalog No.	Standard Pack/Ctn.
With Test Hole						
DO1	16	E 14	1710.0002-L	H201211	01710.000200	20
DO2	63	E 18	1711.0002-L	T215044	01711.000200	
Without Test Hole						
DO3	100	M 30 x 2	1712.0002-L	V215045	01712.000200	10



DO NEOZED Gauge Rings

Size	Rated Current	Catalog Number	Reference Number	New Catalog Number	Gauge Color	Standard Pack/Ctn.
DO1	2	1705.002-L	J216576	01705.002000	Pink	50
	4	1705.004-L	J219681	01705.004000	Brown	
	6	1705.006-L	P206438	01705.006000	Green	
	10	1705.010-L	M213014	01705.010000	Red	
DO2	2	1706.002-L	K216577	01706.002000	Pink	
	4	1706.004-L	S222127	01706.004000	Brown	
	6	1706.006-L	R211983	01706.006000	Green	
	10	1706.010-L	H216069	01706.010000	Red	
	16	1706.016-L	Q218629	01706.016000	Grey	
	20	1706.020-L	S200668	01706.020000	Blue	
	25	1706.025-L	R213524	01706.025000	Yellow	
	35	1706.035-L	J216070	01706.035000	Black	
DO3	50	1706.050-L	R218630	01706.050000	White	
	80	1707.080-L	T200669	01707.080000	Silver	20



DO NEOZED Insulating covers

Single Pole for Ceramic Fuse Bases:

	Poles	Catalog Number	Reference Number	Standard Pack/Ctn.
D01/D02 With marking area	1	1718.7-L	V200670	50
D01/D02 With marking area	3	1732.7-L	M216579	20
D03 Without marking area	1	1728-L	V211986	20
D01/D02 Cover - cap	1	1721.03-L	X201730	40

DO Type (NEOZED)

DO NEOZED Fuse Bases

Screw mounting without shock-proof protection cover, 230VAC and 400VDC

Size	Rated Current	Pole	Max Cross Sect. mm ²	Catalog Number	Reference Number	New Catalog No.	Standard Pack/Ctn.	Terminal Type
D01	16	1	4	1720.1-L	Z216061	01720.100000	20	1
D02	63		25	1721.2-L	M214532	01721.200000		2
D02	63		4	1721.4-L	F213008	01721.400000		4
D03	100		50	1722.4-L	J213011	01722.400000		10
D01	16	3	4	1730.1-L	K200661	01730.100000	5	1
D02	63		25	1731.2-L	F216573	01731.200000		2
D02	63		4	1731.4-L	K206365	01731.400000		4



Snap-on fastening without shock-proof protection cover, 230VAC and 400VDC

Size	Rated Current	Pole	Max Cross Sect. mm ²	Catalog Number	Reference Number	New Catalog No.	Standard Pack/Ctn.	Terminal Type
D01	16	1	4	1720.15-L	J200660	01720.150000	20	1
D02	63		25	1721.25-L	J218623	01721.250000		2
D02	63		4	1721.45-L	W215552	01721.450000		4
D03	100		50	1722.45-L	Q214535	01722.450000		10
D01	16	3	4	1730.15-L	B216063	01730.152000	5	3
D02	63		25	1731.252-L	Y217601	01731.252000		2
D02	63		4	1731.452-L	M211979	01731.452000		4



Snap-on fastening without shock-proof protection cover, 230VAC and 400VDC

Size	Rated Current	Pole	Max Cross Sect. mm ²	Catalog Number	Reference Number	New Catalog No.	Standard Pack/Ctn.	Terminal Type
D01	16	1	4	1720.17-L	B211463	01720.170000	20	1
D01				1721.37-L	T215550	01720.370000		3
D01		3		1730.172-L	A219144	01730.172000		5
D02	63	1	25	1721.27-L	M200663	01721.270000	20	2
D02				1721.47-L	K218624	01721.470000		4
D02		3		1731.272-L	E222874	01731.272000	5	2
D02				1731.472-L	K213518	01731.472000		4
D03	100	1	50	1722.47-L	F216067	01722.470000	10	4



Terminal Type

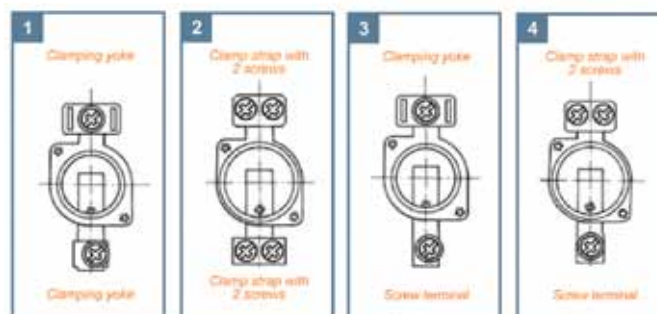

DO Type (NEOZED)

D0 NEOZED Accessories

Special Holding Spring 400VAC/VDC

Size	Catalog Number	Reference Number	New Catalog Number	Standard Pack/Ctn.
D01 Fuse in D02 socket	1713-L	Z215049	01713.000000	50
D02 Fuse in D03 socket	1709-L	P214028	01709.000000	25



Spacer

Size	Catalog Number	Reference Number	New Catalog Number	Standard Pack/Ctn.
D02 fuse in D03 socket	1707-L	T211985	01707.000000	30



Gauge Ring Key

Size	Catalog Number	Reference Number	New Catalog Number	Standard Pack/Ctn.
Gauge rings D01, D02, D03	1708-L	J212505	01708.000000	1



Screw Cap Remover

Plastic screw caps D01, D02	Catalog Number	Reference Number	New Catalog Number	Standard Pack/Ctn.
w/o bottle opener	1716-L	X222936	01716.000000	1
with bottle opener	1716.333-L	Obsolete	Obsolete	1



D Type

500 Volt D-type fuses, screw caps, and fuse bases

Mersen D-type fuses are 500 Volts AC/DC rated with 75kA interrupting rating. They have 5 physical sizes (NDZ, DII, DIII, DIV, and DV) and fit into special screw caps. All fuses have blown-fuse indicators which are visible through the screw cap. Screw caps fit onto single pole bases which are screw or DIN rail mounted. All accessories such as covers, adapter rings, and gauge rings are described.



D-Type Fuse Bases, Snap-on, 500VAC/VDC

Size	Rated Current	Pole	Max Cross Sect. mm ²	Catalog Number	Reference Number	New Catalog No.	Standard Pack/Ctn	Terminal Type
Snap-on fastening without shock-proof protection cover								
D II	25	1	6	685.1-L	K207055	00685.100000	15	1
D III	63	1	16	686.4-L	V215597	00686.400000		2
Snap-on fastening with shock-proof protection cover								
D II	25	1	6	685.11-L	D211511	00685.110000	10	1
D III	63	1	16	686.41-L	C216110	00686.410000		2



D-Type Fuse Bases, Screw-in

Size	Rated Current	Pole	Max Cross Sect. mm ²	Catalog Number	Reference Number	New Catalog No.	Standard Pack/Ctn	Terminal Type
Screw in without shock-proof protection cover								
D II	25	1	6	81.1-L	K218670	00081.100000	15	1
D III	63	1	16	72.4-L	H212021	00072.400000		2
Screw in with shock-proof protection cover								
D II	25	1	6	81.11-L	Z219189	00081.110000	10	1
D III	63	1	16	72.41-L	A212543	00072.410000		2

Terminal Type

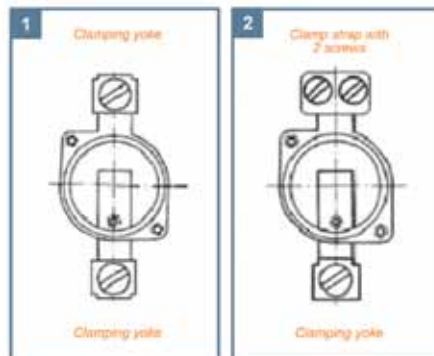

Ratings:

Volts : 500VAC/VDC
I.R. : 75kA I.R. AC
gL-gG : Performance characteristic

Approvals:

- Meet IEC, VDE Standards: IEC 269-3, 3A VDE 0636
- Approved by Lloyds Register of Shipping and Bureau Veritas
- DIN EN 60715

D Type

D Type Fast Acting Fuses, 500VAC/VDC

Size	Rated Current	Catalog Number	Reference Number	New Catalog Number	Gauge Color	Standard Pack/Ctn.
NDZ	2	594.002-L	C222918	NDZFK50V2	PINK	25
	4	594.004-L	L200708	NDZFK50V4	BROWN	
	6	594.006-L	A201250	NDZFK50V6	GREEN	
	10	594.01-L	L201766	NDZFK50V10	RED	
	16	594.016-L	D207049	NDZFK50V16	GRAY	
	20	594.02-L	B211509	NDZFK50V20	BLUE	
	25	594.025-L	Y212541	NDZFK50V25	YELLOW	
D II	2	597.002-L	E213559	DIIFK50V2	PINK	
	4	597.004-L	D214064	DIIFK50V4	BROWN	
	6	597.006-L	L214577	DIIFK50V6	GREEN	
	10	597.01-L	S215089	DIIFK50V10	RED	
	16	597.016-L	A216108	DIIFK50V16	GRAY	
	20	597.02-L	J217128	DIIFK50V20	BLUE	
D III	25	597.025-L	P217639	DIIFK50V25	YELLOW	
	35	598.035-L	J218669	DIIFK50V35	BLACK	
	50	598.05-L	J222165	DIIFK50V50	WHITE	
	63	598.063-L	M200709	DIIFK50V63	COPPER	



D Type gG Fuses, 500VAC

Size	Rated Current	Catalog Number	Reference Number	New Catalog Number	Gauge Color	Standard Pack/Ctn.
NDZ	2	594.0027-L	W212539	NDZGG50V2	PINK	25
	4	594.0047-L	G213055	NDZGG50V4	BROWN	
	6	594.0067-L	C213557	NDZGG50V6	GREEN	
	10	594.0107-L	B214062	NDZGG50V10	RED	
	16	594.0167-L	J214575	NDZGG50V16	GRAY	
	20	594.0207-L	Q215087	NDZGG50V20	BLUE	
	25	594.0257-L	Q215593	NDZGG50V25	YELLOW	
D II	2	597.0027-L	Z219718	DIIGG50V2	PINK	
	4	597.0047-L	G222163	DIIGG50V4	BROWN	
	6	597.0067-L	B222917	DIIGG50V6	GREEN	
	10	597.0107-L	K200707	DIIGG50V10	RED	
	16	597.0167-L	K201765	DIIGG50V16	GRAY	
	20	597.0207-L	A211508	DIIGG50V20	BLUE	
D III	25	597.0257-L	X212540	DIIGG50V25	YELLOW	
	35	598.0357-L	C214063	DIIGG50V35	BLACK	
	50	598.0507-L	K214576	DIIGG50V50	WHITE	
D IV	63	598.0637-L	R215088	DIIGG50V63	COPPER	
	80	595.0807-L	V216609	DIVGG50V80	SILVER	
D V	100	595.1007-L	M217637	DIVGG50V100	RED	
	125	596.1257-L	V218150	DVGG50V125	YELLOW	
	160	596.1607-L	G218667	DVGG50V160	COPPER	
	200	596.2007-L	W219186	DVGG50V200	BLUE	



Dimensions (mm)

Type	NDZ	D II	D III	D IV	D V
A Ø	12	22	27	37	49.9
B	50	50	50	63	63
d	E16	E 27	E 33	R 1¼	R2

D Type

D Type Screw Caps, 500VAC/VDC

Size	Rated Current	Cap Thread	Catalog No.	New Ref. No.	New Cat. No.	Standard Pack/Ctn.
Porcelain with test hole						
D II	25	E 27	690.0002-L	E218619	00690.000200	20
D III	63	E 33	691.0002-L	B213004	00691.000200	
Porcelain without test hole						
NDZ	25	E 16	589-L	Z216613	00589.000000	50
D II	25	E 27	690-L	Z218108	00690.000000	20
D III	63	E 33	691-L	F211973	00691.000000	
Plastic with test hole						
D II	25	E 27	2071-L	L201720	02071.000000	20
D II	63	E 33	2072-L	E214019	02072.000000	



D Type Gauge Pieces

Size	Rated Current	Gauge Color	Catalog No.	New Ref. No.	New Cat. No.	Standard Pack/Ctn.
NDZ	2	pink	1655.002-L	B212544	01655.002000	50
	4	brown	1655.004-L	M213060	01655.004000	
	6	green	1655.006-L	H213562	01655.006000	
	10	red	1655.010-L	G214067	01655.010000	
	16	gray	1655.016-L	P214580	01655.016000	



D Type Screw Gauge Pieces

Size	Rated Current	Gauge Color	Catalog No.	New Ref. No.	New Cat. No.	Standard Pack/Ctn.
D II	2	pink	1657.002-L	A219190	01657.002000	25
	4	brown	1657.004-L	D219722	01657.004000	
	6	green	1657.006-L	L222167	01657.006000	
	10	red	1657.010-L	F222921	01657.010000	
	16	gray	1657.016-L	P200711	01657.016000	
	20	blue	1657.020-L	D201253	01657.020000	
	25	yellow	1657.025-L	P201769	01657.025000	
D III	35	black	1658.035-L	C207071	01658.035000	25
	50	white	1658.050-L	E211512	01658.050000	
	63	copper	1658.063-L	J212022	01658.063000	



D Type Gauge Rings

Size	Rated Current	Gauge Color	Catalog No.	New Ref. No.	New Cat. No.	Standard Pack/Ctn.
D II	2	pink	1652.002-L	W215092	01652.002000	50
	4	brown	1652.004-L	W215598	01652.004000	
	6	green	1652.006-L	D216111	01652.006000	
	10	red	1652.010-L	A216614	01652.010000	
	16	gray	1652.016-L	M217131	01652.016000	
	20	blue	1652.020-L	S217642	01652.020000	
	25	yellow	1652.025-L	A218155	01652.025000	
D III	2	pink	1653.002-L	M218672	01653.002000	50
	4	brown	1653.004-L	E219723	01653.004000	
	6	green	1653.006-L	M222168	01653.006000	
	10	red	1653.010-L	G222922	01653.010000	
	16	gray	1653.016-L	Q200712	01653.016000	
	20	blue	1653.020-L	E201254	01653.020000	
	25	yellow	1653.025-L	Q201770	01653.025000	
	35	black	1653.035-L	L207079	01653.035000	
50	white	1653.050-L	F211513	01653.050000		



D Type Accessories

D Type Accessories

Key for D gauge pieces

Size	Cap Thread	Catalog Number	New Reference Number	New Catalog Number	Standard Pack/Ctn.
D II, D III		1657.993-L	E216112	01657.993000	10

D Insulating single pole cover, ceramic

D II (40mm width)		685.7-L*	H214068	00685.700000	30
D III (50mm width)		686.7-L*	X215093	00686.700000	
D II (45mm width)		685.709-L	Q214581	00685.709000	
D III (54mm width)		686.709-L	X215599	00686.709000	

*Standard version

D Touch protection rings

Plastic

D II		181.9-L	K222120	00181.900000	50
D III		182.9-L	A222870	00182.900000	40

D Adapter fittings

for D II fuses in D III bases

D II / D III		581-L	C212545	00581.000000	24
--------------	--	-------	---------	--------------	----

D Locking caps

D II Supply boards ¹	E 27	2071.8-L	B216615	02071.800000	10
D II Industry ²	E 33	2071.81-L	N217132	02071.810000	
D III Supply boards ¹	E27	2072.8-L	T217643	02072.800000	
D III Industry ²	E 33	2072.81-L	B218156	02072.810000	

¹ black top, red screw pitch

² red top, black screw pitch

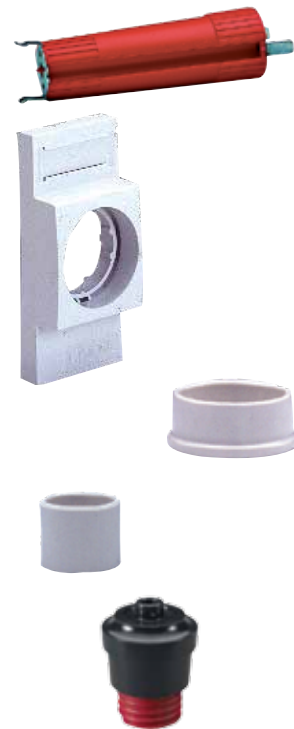

gl-gG, aM NH Dimension Knife-Blade Fuse-Links

NH Dimension Knife-Blade fuse-links, fuse bases, and accessories

Mersen NH Fuse-links, sizes 000, 00, 0, 1, 2, 3, 4 and 4a are rated 500 or 690 Volts AC with breaking capacities of 80kA or 120kA. All fuse-links include an indicator or striker and can accept a microswitch for remote signaling. They all have silver-plated knife blades and ceramic bodies. Accessories include 1, 2, 3 or 4-pole bases, barriers, shields, terminals, microswitch, etc.

gG

Full Range Protection

- Sizes 000, 00, 0, 1, 2, 3, 4, 4a
- 500 and 690 Volt ratings - 2A through 800A
- All ratings include indicator
- All equipped for microswitch mounting

gG

Full Range Protection Fuse-links with Striker

- Sizes 0, 1, 2, 3
- 500 and 690 Volt ratings - 32A through 630A
- All ratings include striker

aM

Short Circuit Protection

- • Sizes 000, 00, 0, 1, 2, 3
- • 400, 500 and 690 Volt ratings - 2A through 800A
- • All ratings include indicator
- • All equipped for microswitch mounting

aM

Short Circuit Protection Fuse-links with Striker

- Sizes 0, 1, 2, 3
- 500 and 690 Volt ratings - 2A through 630A
- All ratings include striker
- Certification
DIN 57636
VDE 60269
NFC 63210, 63211
IEC 269-1, 2, 2A
UNE 21103
- Approved by Lloyds Register of Shipping and Bureau Veritas



Standards:

- DIN 57636
- NFC 63210-63211
- IEC 269-1-2-2A
- UNE 21103
- VDE 0636-2-1, 2-2
- DIN 43620

Approvals:

- Lloyd's Register of Shipping
Bureau Veritas

gl-gG NH Dimension Knife-Blade Fuse-Links

Catalog Numbers, Ratings – gG

Size	Rated Current (A)	Rated Voltage	Catalog Number	New Reference Number	New Catalog Number	Interrupt Rating (A)	Std. Pack
000	2	690V	1C613	E228440	NH000GG69V2	80,000	3
	4		1C619	F228441	NH000GG69V4		3
	6		1C623	G228442	NH000GG69V6		3
	10		1C631	J228444	NH000GG69V10		3
	16		1C635	K228445	NH000GG69V16		3
	20		1C637	L228446	NH000GG69V20		3
	25		1C639	M228447	NH000GG69V25		3
	32		1C643	N228448	NH000GG69V32		3
	35		1C645	P228449	NH000GG69V35		3
	40		1C647	Q228450	NH000GG69V40		3
	50		1C651	R228451	NH000GG69V50		3
	63		1C655	S228452	NH000GG69V63		3
	80		1C659	T228453	NH000GG69V80		3
	00		32	690V	1C743		V228454
35		1C745	W228455		NH00GG69V35	3	
40		1C747	X228456		NH00GG69V40	3	
50		1C751	Y228457		NH00GG69V50	3	
63		1C755	Z228458		NH00GG69V63	3	
80		1C759	A228459		NH00GG69V80	3	
100		1C763	B228460		NH00GG69V100	3	
125		1C765	C228461		NH00GG69V125	3	
0	6	690V	1C023	D228462	NH0GG69V6	80,000	3
	10		1C031	E228463	NH0GG69V10		3
	16		1C035	F228464	NH0GG69V16		3
	20		1C037	G228465	NH0GG69V20		3
	25		1C039	H228466	NH0GG69V25		3
	32		1C043	J228467	NH0GG69V32		3
	35		1C045	K228468	NH0GG69V35		3
	40		1C047	L228469	NH0GG69V40		3
	50		1C051	M228470	NH0GG69V50		3
	63		1C055	N228471	NH0GG69V63		3
	80		1C059	P228472	NH0GG69V80		3
	100		1C063	Q228473	NH0GG69V100		3
	125		1C065	R228474	NH0GG69V125		3
	160		1C069	S228475	NH0GG69V160		3
1	16	690V	1C135	T228476	NH1GG69V16	80,000	3
	20		1C137	V228477	NH1GG69V20		3
	25		1C139	W228478	NH1GG69V25		3
	32		1C143	X228479	NH1GG69V32		3
	35		1C145	Y228480	NH1GG69V35		3
	40		1C147	Z228481	NH1GG69V40		3
	50		1C151	A228482	NH1GG69V50		3
	63		1C155	B228483	NH1GG69V63		3
	80		1C159	C228484	NH1GG69V80		3
	100		1C163	D228485	NH1GG69V100		3
	125		1C165	E228486	NH1GG69V125		3
	160		1C169	F228487	NH1GG69V160		3
	200		1C171	G228488	NH1GG69V200		3
	224		1B173	D219285	NH1GG50V224		3
	250	1B175	E219815	NH1GG50V250	3		

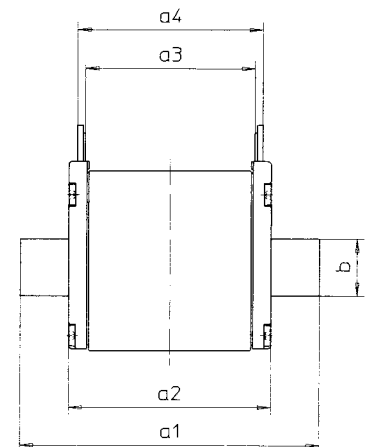

Table continued on next page.

gl-gG NH Dimension Knife-Blade Fuse-Links

Catalog Numbers, Ratings – gG (cont.)

Size	Rated Current (A)	Rated Voltage	Catalog Number	New Reference Number	New Catalog Number	Interrupt Rating (A)	Std. Pack
2	32	690V	1C243	H228489	NH2GG69V32	80,000	3
	35		1C245	J228490	NH2GG69V35		3
	40		1C247	K228491	NH2GG69V40		3
	50		1C251	L228492	NH2GG69V50		3
	63		1C255	M228493	NH2GG69V63		3
	80		1C259	N228494	NH2GG69V80		3
	100		1C263	P228495	NH2GG69V100		3
	125		1C265	Q228496	NH2GG69V125		3
	160		1C269	R228497	NH2GG69V160		3
	200		1C271	S228498	NH2GG69V200		3
	224		1C273	T228499	NH2GG69V224		3
	250		1C275	V228500	NH2GG69V250		3
	300		1C277	W228501	NH2GG69V300		3
	315		1C279	X228502	NH2GG69V315		3
355	1C281	Y228503	NH2GG69V355	3			
3	250	690V	1C375	Z228504	NH3GG69V250	80,000	1
	300		1C377	A228505	NH3GG69V300		1
	315		1C379	B228506	NH3GG69V315		1
	355		1C381	C228507	NH3GG69V355		1
	400		1C383	D228508	NH3GG69V400		1
	425		1C385	E228509	NH3GG69V425		1
	500		1C387	F228510	NH3GG69V500		1
4	400	690V	8004.400765-L	N214004	NH4GG69V400-8	80,000	1
	500		8004.500765-L	Y215025	NH4GG69V500-8		1
	630		8004.630765-L	E215537	NH4GG69V630-8		1
	800		8004.800765-L	K216554	NH4GG69V800-8		1
4a	400	690V	8014.400765-L	W217070	NH4AGG69V400-8	80,000	1
	500		8014.500765-L	H217587	NH4AGG69V500-8		1
	640		8014.630765-L	W222107	NH4AGG69V630-8		1
	800		8014.800765-L	M222858	NH4AGG69V800-8		1



Dimensions (mm)

Size	Rated Current (A)	a1	a2	a3	a4	b	c1	e1	e2	e4	h
NH 690 V gG with voltage-conducting grip lug											
SIZE 000	2-35A	79	53.8	45	49	15	35.8	40	20	6	47.8
SIZE 00	40-100A	79	53.8	45	49	15	35.8	48	30	6	47.8
SIZE 0	6-160A	125	66.8	61	66	15	35	47.5	29.5	6	59.5
SIZE 1	16-160A	135	75	64	68	20	40	44	30	6	52
SIZE 1	200A	135	75	64	68	20	40	47	39	6	52
SIZE 2	35-100A	150	75	64	68	26	48	44	30	6	60
SIZE 2	125-315A	150	75	64	68	26	60	47	39	6	72
SIZE 3	250/300A	150	75	64	68	26	60	47	39	6	72
SIZE 3	315-425A	150	75	64	68	33	60	58	51	6	72
SIZE 3	500A	150	75	64	68	33	60	70	64	6	72
SIZE 4	400-800A	200	85	64	68	33	85	104	89	8	97
SIZE 4a*	400-800A	200	85	86	90	33	85	104	89	6	97

* 4a Screw Contact

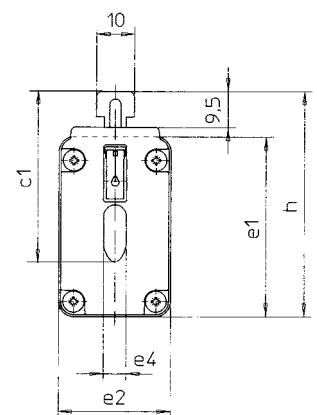

aM NH Dimension Knife-Blade Fuse-Links

Catalog Numbers, Ratings – aM

Size	Rated Current (A)	Rated Voltage	Catalog Number	New Reference Number	New Catalog Number	Interrupt Rating (A)	Std. Pack
000	2	690V	2C613	P227851	NH000AM69V2	80,000	3
	4		2C619	Q227852	NH000AM69V4		3
	6		2C623	R227853	NH000AM69V6		3
	10		2C631	S227854	NH000AM69V10		3
	16		2C635	T227855	NH000AM69V16		3
	20		2C637	V227856	NH000AM69V20		3
	25		2C639	W227857	NH000AM69V25		3
	32		2C643	X227858	NH000AM69V32		3
	35		2C645	Y227859	NH000AM69V35		3
	40		2C647	Z227860	NH000AM69V40		3
	50		2C651	A227861	NH000AM69V50		3
	63		2C655	B227862	NH000AM69V63		3
	00		50	690V	2C751		D227864
63		2C755	E227865		NH00AM69V63	3	
80		2C759	F227866		NH00AM69V80	3	
100		2C763	G227867		NH00AM69V100	3	
125		2C765	H227868		NH00AM69V125	3	
0	6	690V	2C023	K227870	NH0AM69V6	80,000	3
	10		2C031	L227871	NH0AM69V10		3
	16		2C035	M227872	NH0AM69V16		3
	20		2C037	N227873	NH0AM69V20		3
	25		2C039	P227874	NH0AM69V25		3
	32		2C043	Q227875	NH0AM69V32		3
	35		2C045	R227876	NH0AM69V35		3
	40		2C047	S227877	NH0AM69V40		3
	50		2C051	T227878	NH0AM69V50		3
	63		2C055	V227879	NH0AM69V63		3
	80		2C059	W227880	NH0AM69V80		3
	100		2C063	X227881	NH0AM69V100		3
	125		2C065	Y227882	NH0AM69V125		3
	160		2C069	Z227883	NH0AM69V160		3
	1		16	690V	2C135		B227885
20		2C137	C227886		NH1AM69V20	3	
25		2C139	D227887		NH1AM69V25	3	
32		2C143	E227888		NH1AM69V32	3	
35		2C145	F227889		NH1AM69V35	3	
40		2C147	G227890		NH1AM69V40	3	
50		2C151	H227891		NH1AM69V50	3	
63		2C155	J227892		NH1AM69V63	3	
80		2C159	K227893		NH1AM69V80	3	



Microswitch – Sizes 000 to 3

Catalog Number	Ref. Number	Std. Pkg.
MS4L2-5B6+PRES*	F210156	3
MS4L2-5B2+PRES**	G210157	3

*6.3 mm clips. **2.8mm clips

aM NH Dimension Knife-Blade Fuse-Links

Catalog Numbers, Ratings – aM

Size	Rated Current (A)	Rated Voltage	Catalog Number	New Reference Number	New Catalog Number	Interrupt Rating (A)	Std. Pack		
1	100	690V	2C163	L227894	NH1AM69V100	80,000	3		
	125		2C165	M227895	NH1AM69V125		3		
	160		2C169	N227896	NH1AM69V160		3		
	200		2C171	P227897	NH1AM69V200		3		
	224		2C173	Q227898	NH1AM69V224		3		
	250		2C175	R227899	NH1AM69V250		3		
2	35	690V	2C245	L227963	NH2AM69V35	80,000	3		
	40		2C247	M227964	NH2AM69V40		3		
	50		2C251	N227965	NH2AM69V50		3		
	63		2C255	P227966	NH2AM69V63		3		
	80		2C259	Q227967	NH2AM69V80		3		
	100		2C263	R227968	NH2AM69V100		3		
	125		2C265	S227969	NH2AM69V125		3		
	160		2C269	T227970	NH2AM69V160		3		
	200		2C271	V227971	NH2AM69V200		3		
	224		2C273	W227972	NH2AM69V224		3		
	250		2C275	X227973	NH2AM69V250		3		
	315		2C279	Z227975	NH2AM69V315		3		
	355		2C281	A227976	NH2AM69V355		3		
	400		2C283	B227977	NH2AM69V400		3		
3	250	690V	2C375	D227979	NH3AM69V250	80,000	1		
	300		2C377	E227980	NH3AM69V300		1		
	315		2C379	F227981	NH3AM69V315		1		
	355		2C381	G227982	NH3AM69V355		1		
	400		2C383	H227983	NH3AM69V400		1		
	425		2C385	J227984	NH3AM69V425		1		
	450		2C386	K227985	NH3AM69V450		1		
	500		2C387	L227986	NH3AM69V500		1		
	630		500V	2B389	M227987		NH3AM50V630	120,000	1
	800		400V	2A391	W228524		NH3AM40V800	120,000	1

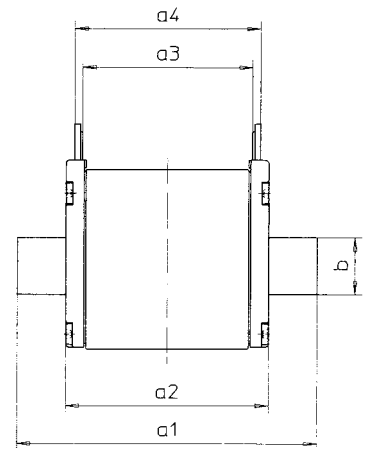

Dimensions (mm)

Size	Rated Current (A)	a1	a2	a3	a4	b	c1	e1	e2	e4	h
NH 690 V aM with voltage-conducting grip lug											
SIZE 000	2-35A	79	53.8	45	49	15	35.8	40	20	6	47.8
SIZE 00	40-100A	79	53.8	45	49	15	35.8	48	30	6	47.8
SIZE 0	6-160A	125	66.8	61	66	15	35	47.5	29.5	6	59.5
SIZE 1	16-160A	135	75	64	68	20	40	44	30	6	52
SIZE 1	200A	135	75	64	68	20	40	47	39	6	52
SIZE 2	35-100A	150	75	64	68	26	48	44	30	6	60
SIZE 2	125-315A	150	75	64	68	26	60	47	39	6	72
SIZE 3	250/300A	150	75	64	68	26	60	47	39	6	72
SIZE 3	315-425A	150	75	64	68	33	60	58	51	6	72
SIZE 3	500A	150	75	64	68	33	60	70	64	6	72

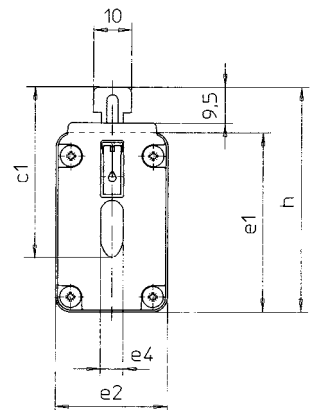

Class C Canadian Fuses

Class C fuses

Mersen Class C fuses have British standard (BS88) dimensions and are exact replacements for the British fuses and older HRCII-C fuses. Class C fuses are not dimensionally or electrically interchangeable with other North American fuses. They feature ceramic bodies and bolt-in mounting. They are for short-circuit protection only, in motor controllers, for example, where overload protection is provided by an overload relay.

* Ceramic version available upon request

Highlights:

- BS88 dimensions
- Fast-acting

Applications:

- Short circuit and back-up protection of motor controllers and components

Catalog Numbers (amps)

FES2	FES80	FESF250
FES4	FES100	FESF300
FES6	FES125	FESF350
FES10	FES150	FESF400
FES15	FES200	FESC250
FES20	FESC80	FESC300
FES25	FESC100	FESC350
FES30	FESC125	FESC400
FES40	FESC150	FESC450
FES50	FESC200	FESC500
FES60		FESC600



Ratings:

- Volts** : 600VAC
: 460VDC
: 450VDC
: 350VDC
- Amps** : 2 to 600A
- I.R.** : 200kA I.R. AC (2-600A)
: 40kA I.R. DC
- 460VDC:**
FES (2-60A)
FESF (250-400A)
FESC (250-400A)
- 450VDC:**
FESC (450-600A)

- 350VDC:**
FES (80-100A)
FESC (80-200A)

Approvals:

- CSA Certified HRCII-MISC
IEC 269-2-1



Class C Canadian Fuses

Class C Dimensions Inches (mm)

Catalog No.	A	B	D	E	F	G	H	K
FES 2-30	2.06 (52.3)	0.81 (20.6)	3.31 (84.1)	0.35 (8.9)	0.06 (1.6)	2.83 (71.9)	0.20 (5.2)	0.84 (21.3)
FES 40-60	2.19 (55.6)	1.06 (26.9)	3.44 (87.4)	0.50 (12.7)	0.06 (1.6)	2.77 (70.4)	0.20 (5.2)	1.07 (27.2)
FES 80-100	2.69 (68.3)	1.34 34.0	4.31 (109.5)	0.75 19.1	0.13 3.2	3.64 (92.5)	0.34 (8.7)	1.43 (36.3)
FES 125-200	2.69 (68.3)	1.58 (40.1)	4.31 (109.5)	0.75 (19.1)	0.13 (3.2)	3.64 (92.5)	0.34 (8.7)	1.69 (42.9)
FESC 80-100	2.44 (61.9)	1.34 (33.9)	5.31 (134.9)	0.75 (19.1)	0.13 (3.2)	4.28 (108.7)		
FESC 125-200	2.44 (61.9)	1.59 (40.3)	5.31 (134.9)	0.75 (19.1)	0.13 (3.2)	4.28 (108.7)		
FESF 250-400	3.00 (76.2)	2.00 (50.8)	5.38 (136.7)	1.00 (25.4)	0.25 (6.4)	4.25 (108.0)	0.41 (10.4)	
FESC 250-400	3.00 (76.2)	2.00 (50.8)	8.25 (209.6)	1.00 (25.4)	0.25 (6.4)	5.16 (131.0)		
FESC 450-600	3.00 (76.2)	2.88 (73.0)	8.25 (209.6)	1.00 (25.4)	0.38 (9.5)	5.06 (128.6)		

Class C Dimensions Inches (mm)

FES2-30
FES40-60
FES80-100
FES125-200

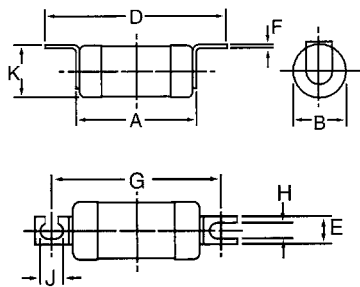

FESC80-100
FESC125-200
FESF250-400

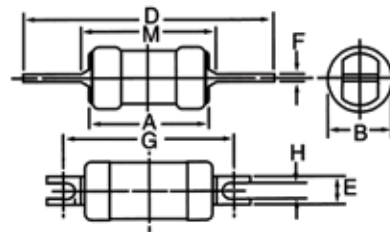

FESC250-400
FESC450-600

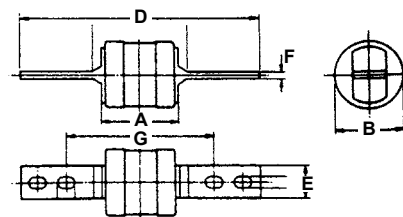

Class H NRN/NRS/Canadian Fuses

NRN & NRS non-time delay fuses

Mersen NRN (250V) and NRS (600V) fuses are standard non-time delay fuses, with a 10kA short circuit rating. 250 Volt NRN15 through NRN60 fuses are certified as Type "P" fuses, satisfying the Canadian Electrical Code for low melting-point non-time delay fuses. Also qualifying for Type "P" are OTN15 through OTN60, which are Class K-5 fuses with a 50kA short circuit rating (found in the OT/OTS section of this catalog).

250V NRN Fuses – Dimensions

Ampere Rating	Dimensions - Inches (mm)				
	A	B	C	D	E
1-30	2.00 (50.8)	0.56 (14.2)			0.50 (12.7)
35-60	3.00 (76.2)	0.81 (20.6)			0.63 (16.0)
70-100	5.88 (149)	1.06 (26.9)	0.13 (3.18)	0.75 (19.1)	1.00 (25.4)
110-200	7.13 (181)	1.63 (41.4)	0.19 (4.76)	1.13 (28.7)	1.38 (35.1)
225-400	8.63 (219)	2.13 (54.1)	0.25 (6.35)	1.63 (41.4)	1.88 (47.8)
450-600	10.4 (264)	2.63 (66.8)	0.25 (6.35)	2.00 (50.8)	2.25 (57.2)

600V NRS Fuses – Dimensions

Ampere Rating	Dimensions - Inches (mm)				
	A	B	C	D	E
1-30	5.00 (127)	0.81 (20.6)			0.63 (16.0)
35-60	5.50 (139)	1.06 (26.9)			0.63 (16.0)
70-100	7.88 (200)	1.38 (35.1)	0.13 (3.18)	0.75 (19.1)	1.00 (25.4)
110-200	9.63 (244)	1.88 (47.8)	0.19 (4.76)	1.13 (28.7)	1.38 (35.1)
225-400	11.6 (295)	2.63 (66.8)	0.25 (6.35)	1.63 (41.4)	1.88 (47.8)
450-600	13.4 (340)	3.13 (79.5)	0.25 (6.35)	2.00 (50.8)	2.25 (57.2)

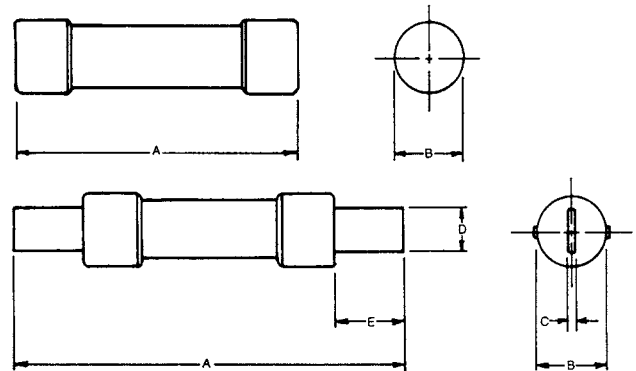

250V Fuse Ampere Ratings, Catalog Numbers

NRN1	NRN15*	NRN50*	NRN125	NRN350
NRN2	NRN20*	NRN60*	NRN150	NRN400
NRN3	NRN25*	NRN70	NRN175	NRN450
NRN4	NRN30*	NRN80	NRN200	NRN500
NRN5	NRN35*	NRN90	NRN250	NRN600
NRN6	NRN40*	NRN100	NRN250	
NRN10	NRN45*	NRN110	NRN300	

* CSA Type "P"

600V Fuse Ampere Ratings, Catalog Numbers

NRS1	NRS15	NRS50	NRS125	NRS350
NRS2	NRS20	NRS60	NRS150	NRS400
NRS3	NRS25	NRS70	NRS175	NRS450
NRS4	NRS30	NRS80	NRS200	NRS500
NRS5	NRS35	NRS90	NRS250	NRS600
NRS6	NRS40	NRS100	NRS250	
NRS10	NRS45	NRS110	NRS300	

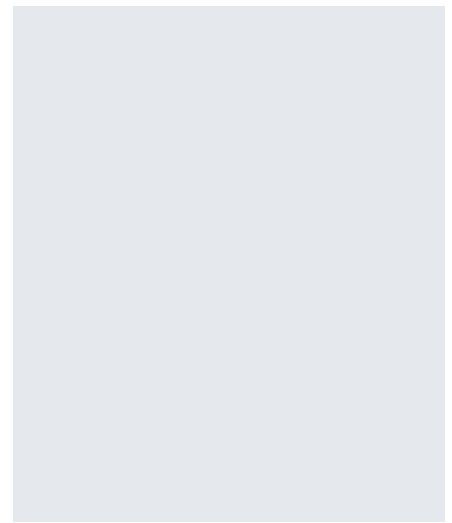

Class H CRN/CRS/Canadian Fuses

CRN & CRS time delay fuses

Mersen CRN and CRS fuses are standard fuses, Type "D", with 10kA short circuit rating. Type "D" fuses satisfy the Canadian Electrical Code requirement for low melting-point fuses.

250V CRN Fuses – Dimensions

Ampere Rating	Dimensions - Inches (mm)				
	A	B	C	D	E
15-30	2.00 (50.8)	0.56 (14.2)			0.50 (12.7)
35-60	3.00 (76.2)	0.81 (20.6)			0.63 (16.0)
70-100	5.88 (149)	1.06 (26.9)	0.13 (3.18)	0.75 (19.1)	1.00 (25.4)
110-200	7.13 (181)	1.63 (41.4)	0.19 (4.76)	1.13 (28.7)	1.38 (35.1)
225-400	8.63 (219)	2.13 (54.1)	0.25 (6.35)	1.63 (41.4)	1.88 (47.8)
450-600	10.4 (264)	2.63 (66.8)	0.25 (6.35)	2.00 (50.8)	2.25 (57.2)

600V CRS Fuses – Dimensions

Ampere Rating	Dimensions - Inches (mm)				
	A	B	C	D	E
15-30	5.00 (127)	0.81 (20.6)			0.63 (16.0)
35-60	5.50 (139)	1.06 (26.9)			0.63 (16.0)
70-100	7.88 (200)	1.38 (35.1)	0.13 (3.18)	0.75 (19.1)	1.00 (25.4)
110-200	9.63 (244)	1.88 (47.8)	0.19 (4.76)	1.13 (28.7)	1.38 (35.1)
225-400	11.6 (295)	2.63 (66.8)	0.25 (6.35)	1.63 (41.4)	1.88 (47.8)
450-600	13.4 (340)	3.13 (79.5)	0.25 (6.35)	2.00 (50.8)	2.25 (57.2)

250V Fuse Ampere Ratings, Catalog Numbers*

CRN15	CRN60	CRN200
CRN17-1/2	CRN70	CRN225
CRN20	CRN80	CRN250
CRN25	CRN90	CRN300
CRN30	CRN100	CRN350
CRN35	CRN110	CRN400
CRN40	CRN125	CRN450
CRN45	CRN150	CRN500
CRN50	CRN175	CRN600

* For 1/10 - 12A ratings use Tri-onic TR-R.

600V Fuse Ampere Ratings, Catalog Numbers**

CRS15	CRS60	CRS200
CRS17-1/2	CRS70	CRS225
CRS20	CRS80	CRS250
CRS25	CRS90	CRS300
CRS30	CRS100	CRS350
CRS35	CRS110	CRS400
CRS40	CRS125	CRS450
CRS45	CRS150	CRS500
CRS50	CRS175	CRS600

** For 1/10 - 12 ratings use Tri-onic TRS-R.



Ratings:

CRN

Volts : 250VAC
Amps : 15 to 600A
I.R. : 10kA I.R. AC

CRS

Volts : 600VAC
Amps : 15 to 600A
I.R. : 10kA I.R. AC

Approvals:

- CSA Certified Type "D"

