

"ODYSSEY SERIES" AC Contactors & Starters, DC Operated (Conventional DC Coils)

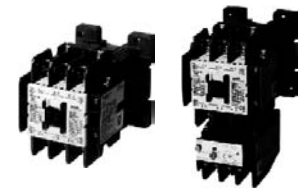

■ NON-REVERSING CONTACTORS UL File No. E42419, cUL listed

1 Phase HP Rating (Full load ampere)		3 Phase HP Ratings (Full load ampere)				Rated thermal current for non inductive / resistive load	Qty. of Aux. Contacts		Part Number	Fuji Type	Frame Size
100-120V	220-240V	200-208V	220-240V	440-480V	550-600V		NO	NC			
2 (24)	5(28)	71/2 (25.3)	10 (28)	25 (34)	25 (27)	50	2	2	3GC0T0#22	SC-N1/G	0T
3 (34)	71/2(40)	10 (32.2)	15 (42)	30 (40)	30 (32)	60	2	2	3GC1Q0#22	SC-N2/G	1Q
3 (34)	10(50)	15 (48.3)	20 (54)	40 (52)	40 (41)	80	2	2	3GC2F0#22	SC-N2S/G	2F
5 (34)	15(68)	20 (62.1)	25 (68)	50 (65)	50 (52)	100	2	2	3GC2H0#22	SC-N3/G	2H

■ REVERSING CONTACTORS UL File No. E42419, cUL listed

1 Phase HP Rating (Full load ampere)		3 Phase HP Ratings (Full load ampere)				Rated thermal current for non inductive / resistive load	Qty. of Aux. Contacts		Part Number	Fuji Type	Frame Size
100-120V	220-240V	200-208V	220-240V	440-480V	550-600V		NO	NC			
2 (24)	5 (28)	71/2 (25.3)	10 (28)	25 (34)	25 (27)	50	2	2	3GD0T0#22	SC-N1RM/G	0T
3 (34)	71/2 (40)	10 (32.2)	15 (42)	30 (40)	30 (32)	60	2	2	3GD1Q0#22	SC-N2RM/G	1Q
3 (34)	10 (50)	15 (48.3)	20 (54)	50 (65)	40 (41)	80	2	2	3GD2F0#22	SC-N2SRM/G	2F
5 (34)	15 (68)	20 (62.1)	25 (68)	50 (52)	50 (52)	100	2	2	3GD2H0#22	SC-N3RM/G	2H

■ NON-REVERSING MOTOR STARTERS UL File No. E42419, cUL listed

1 Phase HP Rating (Full load ampere)		3 Phase HP Ratings (Full load ampere)				Rated thermal current for non inductive / resistive load	Qty. of Aux. Contacts		Part Number	Fuji Type	Frame Size
100-120V	220-240V	200-208V	220-240V	440-480V	550-600V		NO	NC			
2 (24)	5 (28)	71/2 (25.3)	10 (28)	25 (34)	25 (27)	50	2	2	3GW0T0#*22K	SW-N1/G2E	0T
3 (34)	71/2 (40)	10 (32.2)	15 (42)	30 (40)	30 (32)	60	2	2	3GW1Q0#*22K	SW-N2/G2E	1Q
3 (34)	10 (50)	15 (48.3)	20 (54)	40 (52)	40 (41)	80	2	2	3GW2F0#*22K	SW-N2S/G2E	2F
5 (34)	15 (68)	20 (62.1)	25 (68)	50 (65)	50 (52)	100	2	2	3GW2H0#*22K	SW-N3/G2E	2H

■ REVERSING MOTOR STARTERS UL File No. E42419, cUL listed

1 Phase HP Rating (Full load ampere)		3 Phase HP Ratings (Full load ampere)				Rated thermal current for non inductive / resistive load	Qty. of Aux. Contacts		Part Number	Fuji Type	Frame Size
100-120V	220-240V	200-208V	220-240V	440-480V	550-600V		NO	NC			
2 (24)	5 (28)	71/2 (25.3)	10 (28)	25 (34)	25 (27)	50	2	2	3GX0T0#*22K	SW-N1RM/G2E	0T
3 (34)	71/2 (40)	10 (32.2)	15 (42)	30 (40)	30 (32)	60	2	2	3GX1Q0#*22K	SW-N2RM/G2E	1Q
3 (34)	10 (50)	15 (48.3)	20 (54)	40 (52)	40 (41)	80	2	2	3GX2F0#*22K	SW-N2SRM/G2E	2F
5 (34)	15 (68)	20 (62.1)	25 (68)	50 (65)	50 (52)	100	2	2	3GX2H0#*22K	SW-N3RM/G2E	2H

If larger contactors or motor starters are required, please turn to page 25-27.

EXPLANATION OF PART NUMBER SYSTEM

3 G W 0 T 0 # * 2 2 K

• **PRODUCT LINE**
3=Odyssey Series

• **OPERATION**
G=DC Coil

• **DESCRIPTION**
C=Non-Reversing Contactor
D=Reversing Contactor
W=Non-Reversing Motor Starter
X=Reversing Motor Starter

• **FRAME SIZE**

• **FRAME ENCLOSURE**
0=Open Frame, No Enclosure

• **OVERLOAD TYPE**
K=Open Phase Protection
offered as a standard
(Motor Starters Only
Omit for Contactors)

• **QUANTITY OF N.C. AUX. CONTACTS**

• **QUANTITY OF N.O. AUX. CONTACTS**

• **OVERLOAD RANGE**
Select appropriate letter from chart
on page 29
(Motor Starters Only
Omit for Contactors)

• **COIL VOLTAGE**
Select code from chart on next page

"ODYSSEY SERIES" AC Contactors & Starters, DC Operated (Conventional DC Coils)

AVAILABLE COILS

Code Letter	DC Coil
T	12V
M	24V
N	48V
1	100V
R	110V
2	200V
S	220V

If AC operation is required,
please turn to page 21-22.

COIL CHARACTERISTICS

Frame Size	Power Consumption (VA)		Pick-up Voltage (V)	Drop-out Voltage (V)	Operating Time (ms)	
					Coil ON ↓ Contact ON	Coil OFF ↓ Contact OFF
0T	9	9	10-14	4-8	40-48	17-21
1Q	9	9	10-14	4-8	40-48	17-21
2F	12	12	10-14	3-7	60-70	15-19
2H	12	12	10-14	3-7	60-70	15-19

This data is based on 24-26VDC coil, tested at 24VDC.
For additional coil data, please see page 50.

WIRING DIAGRAMS / AUXILIARY CONTACT INFORMATION

NON-REVERSING CONTACTORS

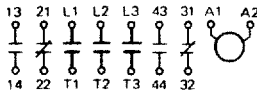

NON-REVERSING MOTOR STARTERS

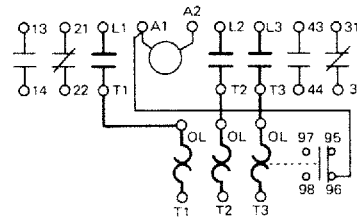

REVERSING CONTACTORS

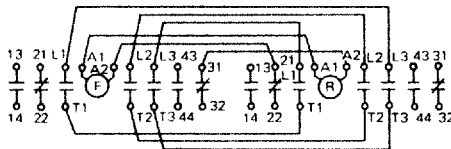

REVERSING MOTOR STARTERS

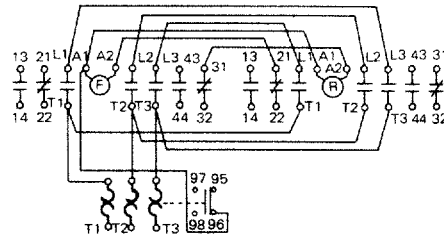

AUXILIARY CONTACT RATINGS

Operating	Contact rating Code Designation	Continuous Ampere Rating	Current-Make/Break (A)			
			110 to 120V	220 to 240V	440 to 480V	550 to 600V
AC	A600	10	60/6	30/3	15/1.5	12/1.2
DC	Q300	10	120V		240V	
			0.55/0.55	0.27/0.27		

Notes:

- All Odyssey series contactors and starters come equipped with 2NO + 2NC auxiliary contacts standard.
- Reversing contactors & starters from Frame size 0T through 2H can be constructed in the field. See Accessories on pages 31-32 for details. Large frame size reversing units only factory assembled.

"ODYSSEY SERIES" Dimensions

3NW5F0#*22K
3NW5H0#*22K

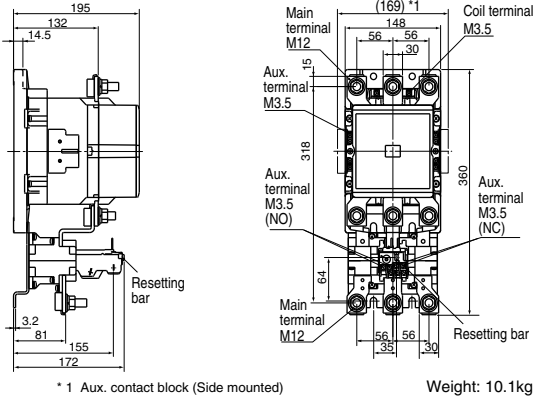

■ DC OPERATED CONTACTORS/OPEN TYPE Approximate Dimensions, mm

3GC0T0#22
3GC1Q0#22

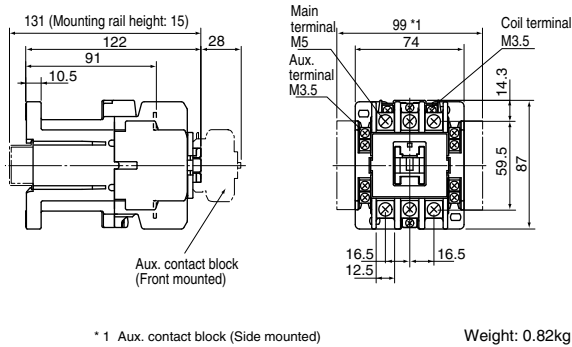

3GC2F0#22
3GC2H0#22

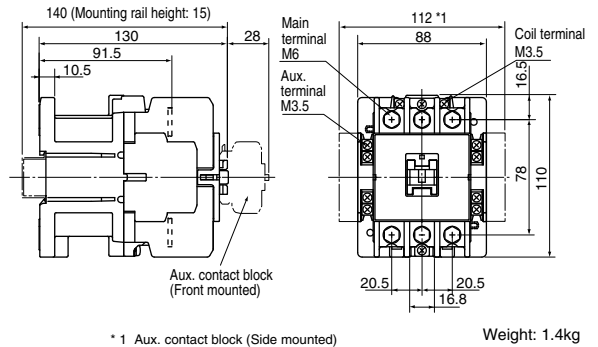

■ DC OPERATED STARTERS/OPEN TYPE Approximate Dimensions, mm

3GW0T0#*22K
3GW1Q0#*22K

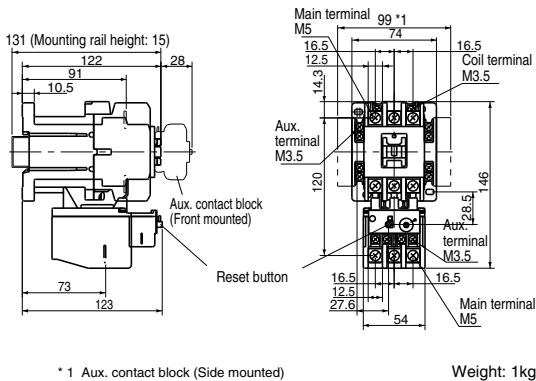

3GW2F0#*22K
3GW2H0#*22K

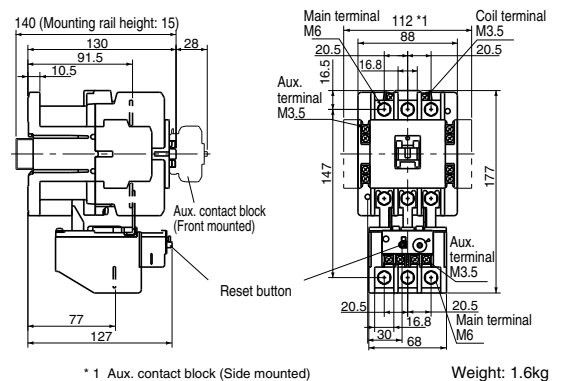

For exact mounting hole locations, please refer to the chart on page 46.

"ODYSSEY SERIES" Mounting Pitch Dimensions

■ NON-REVERSING CONTACTORS AND STARTERS Approximate Mounting Dimensions, mm

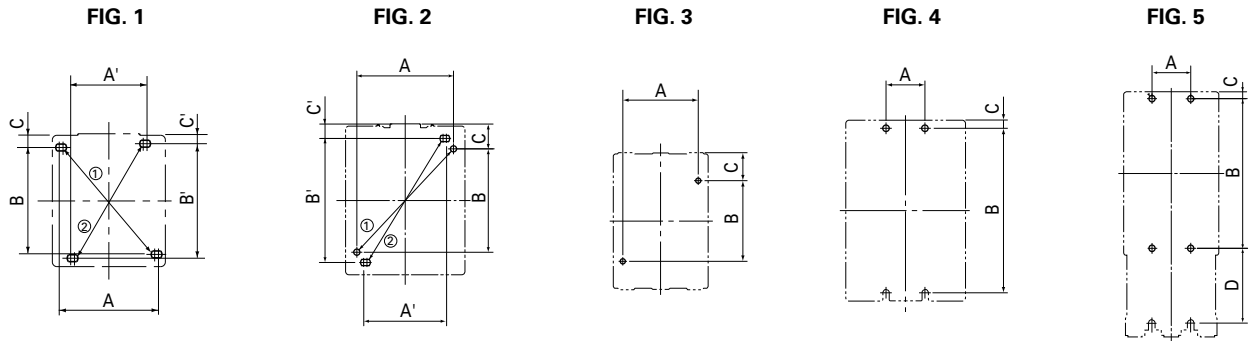

Frame Size	Contactors								Starters								
	Fig.No.	A	B	C	A'	B'	C'	Correct Screw Size	Fig.No.	A	B	C	A'	B'	C'	D	Correct Screw Size
0T	1	60-65	70	9	45-50	75	6.5	2-M4	1	60-65	70	9	45-50	75	6.5	-	2-M4
1Q	1	60-65	70	9	45-50	75	6.5	2-M4	1	60-65	70	9	45-50	75	6.5	-	2-M4
2F	2	70	75	18	55-60	90	10.5	2-M4	2	70	75	18	55-60	90	10.5	-	2-M4
2H	2	70	75	18	55-60	90	10.5	2-M4	2	70	75	18	55-60	90	10.5	-	2-M4
2T	3	70	75	26	-	-	-	2-M4	3	70	75	26	-	-	-	-	2-M4
3F	3	70	75	26	-	-	-	2-M4	3	70	75	26	-	-	-	-	2-M4
3H	3	80-90	110	17	-	-	-	2-M5	3	80-90	110	17	-	-	-	-	2-M5
4F	3	80-90	110	23	-	-	-	2-M5	3	80-90	110	23	-	-	-	-	2-M5
4Q	4	45	190	9.5	-	-	-	4-M6	4	45	270	9.5	-	-	-	-	4-M6
4H	4	45	190	9.5	-	-	-	4-M6	4	45	270	9.5	-	-	-	-	4-M6
5F	4	60	220	10	-	-	-	4-M8	5	60	220	10	-	-	-	110	4-M8
5H	4	60	220	10	-	-	-	4-M8	5	60	220	10	-	-	-	110	4-M8
6F & 6H	4	250	250	-	-	-	-	4-M10	-	-	-	-	-	-	-	-	-

■ REVERSING CONTACTORS AND STARTERS Approximate Mounting Dimensions, mm

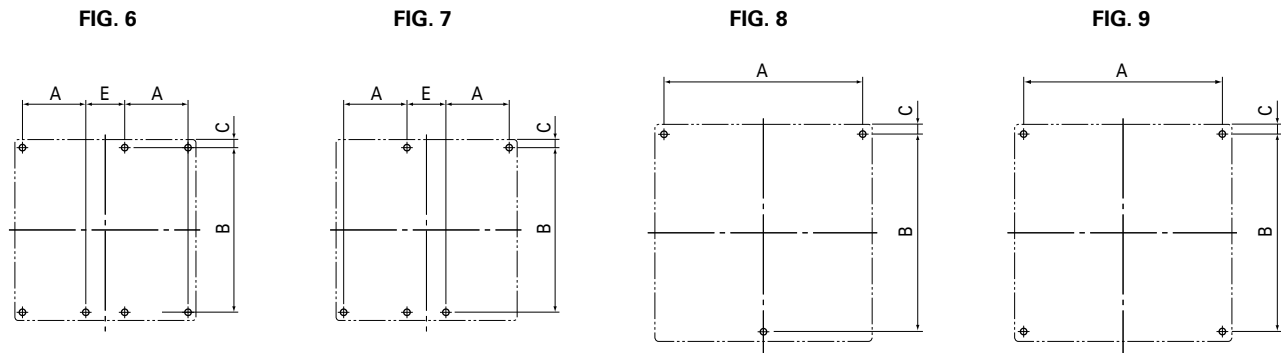

Frame Size	Reversing Contactors						Reversing Starters					
	Fig.No.	A	B	C	E	Correct Screw Size	Fig.No.	A	B	C	E	Correct Screw Size
0T	6	65	70	9	22	4-M4	6	65	70	9	22	4-M4
1Q	6	65	70	9	22	4-M4	6	65	70	9	22	4-M4
2F	7	70	75	18	30	4-M4	7	70	75	18	30	4-M4
2H	7	70	75	18	30	4-M4	7	70	75	18	30	4-M4
2T	8	200	150	7.5	-	3-M5	8	200	150	7.5	-	3-M5
3F	8	200	150	7.5	-	3-M5	8	200	150	7.5	-	3-M5
3H	8	220	175	7.5	-	3-M5	8	220	175	7.5	-	3-M5
4F	8	260	200	7.5	-	3-M6	8	260	200	7.5	-	3-M6
4Q	9	300	250	10	-	4-M6	9	300	350	10	-	4-M6
4H	9	300	250	10	-	4-M6	9	300	350	10	-	4-M6
5F	9	300	300	15	-	4-M8	9	300	450	15	-	4-M8
5H	9	300	300	15	-	4-M8	9	300	450	15	-	4-M8

TECHNICAL PERFORMANCE DATA

■ STANDARD CONDITIONS

- Ambient temperature should not exceed +40°C and the average over a period of 4 hours should not exceed +35°C. The lower limit of the ambient temperature is -5°C.
- Altitude Restriction
For use at altitudes exceeding 2000 meters (6,600 ft.) please consult Fuji Electric.

■ LIFE EXPECTANCY

Performance Data

Frame size	Current capacity Make/Break	Operating cycles per hour	Life expectancy (million operations)	
			Electrical	Mechanical
0A	12xIe/10xIe	1800	2	10
0F, 0G	12xIe/10xIe	1800	2	10
0Q	12xIe/10xIe	1800	1.5	10
0R, 0H	12xIe/10xIe	1800	2	10
0T, 1Q	12xIe/10xIe	1200	2	10
2F, 2H	12xIe/10xIe	1200	2	5
2T through 5F	12xIe/10xIe	1200	1	5
5H	12xIe/10xIe	1200	0.5	5

■ AUXILIARY CONTACT RATINGS

All Frame Sizes

Operating	Contact rating code designation	Continuous ampere rating	Current-Make/Break (A)			
			110 to 120V	220 to 240V	440 to 480V	550 to 600V
AC	A600	10	60/6	30/3	15/1.5	12/1.2
DC	Q300	10	120V		240V	
			0.55/0.55		0.27/0.27	

Note: Ie: Rated operational current.

Electrical life test: Conforming to IEC947-4-1, AC3.

The endurance test complies with the requirements of international standard IEC, JIS and JEM.

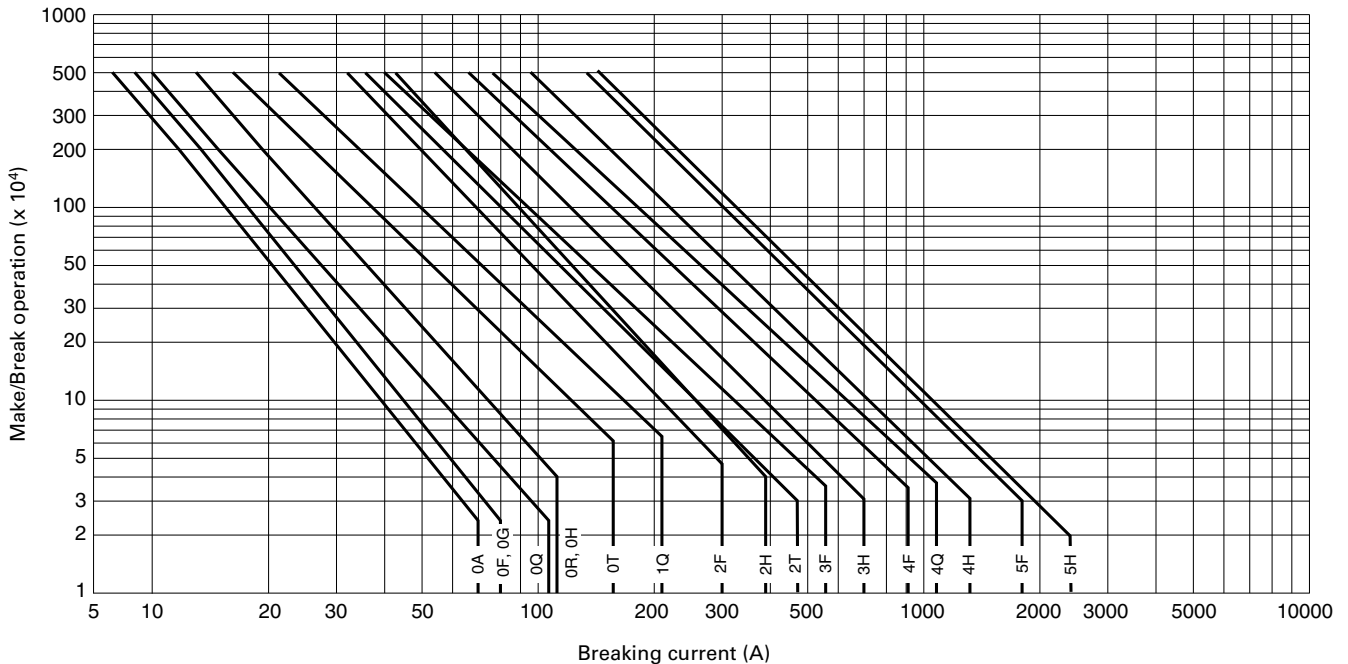

Terminal Tightening Torque Chart

Type No.		Terminal Size		Cable Size Maximum		Applicable Max. Width for Ring Terminal		Tightening Torque	
Contactor or Starter	Thermal Overload Relay	Contactor	Thermal Overload Relay	Contactor	Thermal Overload Relay	Contactor	Thermal Overload Relay	Contactor	Thermal Overload Relay
4NC0A0 4NC0F0 4NC0G0 4NW0A0 4NW0F0 4NW0G0	4NK0A	M3.5	M3.5	12AWG (3.3mm ²)	12AWG (3.3mm ²)	7.7mm	7.7mm	7-9 in.lbs. 0.8-1 Nm	7-9 in.lbs. 0.8-1 Nm
4NC0Q0 4NC0R0 4NC0H0 4NW0Q0 4NW0R0 4NW0H0	4NK0H	M4	M4	10AWG (5.3mm ²)	10AWG (5.3mm ²)	9.7mm	9.7mm	11-13 in.lbs. 1.2-1.5 Nm	11-13 in.lbs. 1.2-1.5 Nm
3NC0T0 3NC1Q0 3NW0T0 3NW1Q0	3NK1Q	M5	M5	6AWG (13.3mm ²)	6AWG (13.3mm ²)	12.4mm	12.4mm	18-22 in.lbs. 2-2.5 Nm	18-22 in.lbs. 2-2.5 Nm
3NC2F0 3NC2H0 3NW2F0 3NW2H0	3NK2H	M6	M6	2AWG (33.6mm ²)	4AWG (21.2mm ²)	16.8mm	16.7mm	35-44 in.lbs. 4-5 Nm	35-44 in.lbs. 4-5 Nm
3NC2T0 3NC3F0 3NW2T0 3NW3F0	3NK3F	M6	M6	1/0AWG (53.5mm ²)	2AWG (33.6mm ²)	22.3mm	16.7mm	35-44 in.lbs. 4-5 Nm	35-44 in.lbs. 4-5 Nm
3NC3H0 3NW3H0	3NK3H	M8	M8	1/0AWG (53.5mm ²)	1/0AWG (53.5mm ²)	22.3mm	22.3mm	80-97 in.lbs. 9-11 Nm	80-97 in.lbs. 9-11 Nm
3NC4F0 3NW4F0	3NK4F	M8	M8	3/0AWG (85mm ²)	1/0AWG (53.5mm ²)	28.9mm	22.3mm	80-97 in.lbs. 9-11 Nm	80-97 in.lbs. 9-11 Nm
3NC4Q0 3NW4Q0	3NK4Q	M10	M10	300MCM (152mm ²)	300MCM (152mm ²)	36.5mm	36.5mm	133-177 in.lbs. 15-20 Nm	133-177 in.lbs. 15-20 Nm
3NC4H0 3NW4H0	3NK4H	M10	M10	300MCM (152mm ²)	300MCM (152mm ²)	36.5mm	36.5mm	133-177 in.lbs. 15-20 Nm	133-177 in.lbs. 15-20 Nm
3NC5F0 3NC5H0 3NW5F0 3NW5H0	3NK5H	M12	M12	400MCM (203mm ²)	400MCM (203mm ²)	44.5mm	44.5mm	310-399 in.lbs. 35-45 Nm	310-399 in.lbs. 35-45 Nm
3NC6F0 3NC6H0	-	M16	-	600MCM (304mm ²)	-	51.0mm	-	663-884 in.lbs. 75-100 Nm	-