

PRODUCT NUMBER
77311-YXX-XXLF

PLATING SEE SHEET 2
PIN STYLE SEE SHEET 2

RoHS COMPATIBLE
SEE NOTE 6

TOTAL NB OF POSITIONS 01 TO 36
OPTION LETTER SEE NOTE 7

PRODUCT NUMBER (BERGSTRIK PACKAGING)
77311-YXX-OOLF

PLATING

1= 0.76µm GOLD/GXT ON CONTACT AREA, 2µm TIN MIN ON TAILS

8= 0.38µm GOLD/GXT ON CONTACT AREA, 2µm TIN MIN ON TAILS

4= 2.0µm TIN MIN FULL PLATED

1.27µm NICKEL MIN UNDERLAYER FOR ALL PLATING VERSIONS

INDICATES THE PRODUCT IS RoHS COMPATIBLE, SEE NOTE 6

POSITIONS PER REEL : 00=36,000 (BERGSTRIK)

PIN STYLE	MATING	SOLDER	OAL
01	5.84	2.41	10.8
02	5.84	3.42	11.8
18	5.84	3.05	11.43
22	7.75	3.05	13.35
24	6.75	2.9	12.2
27	6.6	2.66	11.8

NOTES:

- HOUSING MAT'L : HIGH TEMPERATURE THERMOPLASTIC. UL94V-0 COLOR: BLACK
- PIN MATERIAL : PHOSPHOR BRONZE
- BERGSTIK PRODUCT PACKAGED IN POLYBAGS. BERGSTRIK PRODUCT PACKAGED PER REELS.
- 9N MIN RETENTION IN EITHER DIRECTION
- TO DETERMINE DIMENSIONS :
N = NUMBER OF POSITIONS PER ROW
EXAMPLE : 8 POS N x 2.54 = 20.32mm
- RoHS COMPATIBLE PRODUCT SPECIFICATIONS

a - PLATING:

- "LF" MEANS THE PRODUCT IS LEAD-FREE, 2µm MINIMUM MATTE TIN OVER 1.27µm MINIMUM NICKEL UNDERPLATE.

b - MANUFACTURING PROCESS COMPATIBILITY

- THE HOUSING WILL WITHSTAND EXPOSURE TO 260°C ±5°C SOLDER BATH TEMPERATURE FOR 5 SECONDS IN A WAVE SOLDER APPLICATION WITH A 1.6mm MIN THICK CIRCUIT BOARD.

- REFLOW COMPATIBLE

c - LABELING:

- MEETS PACKAGING SPECS AS PER GS-14-920

d - LEGAL STATEMENT: SEE GS-47-0004

7. OPTIONS : - = POLYBAG PACKAGING

T = TUBE PACKAGING WITHOUT PICK UP CAP

K = TAPE & REEL PACKAGING, WITHOUT PICK UP CAP ONLY FOR P/N 77311-462K04(LF) AND 77311-462K05(LF)

KC = TAPE & REEL PACKAGING WITHOUT PICK UP CAP AND WITH HIGH RETENTION FEATURES

KV = TAPE & REEL PACKAGING WITHOUT PICK UP CAP FOR CUSTOMER DEDICATED PART ONLY FOR P/N 77311-462KV04LF

AV = TAPE & REEL PACKAGING WITH PICK UP CAP FOR CUSTOMER DEDICATED PART

C = HIGH RETENTION FEATURES, SEE SHEET 2

R = RETENTION FEATURES, SEE SHEET 2

IF RETENTION FEATURE "R" AND TUBE PACKAGING "T" ARE BOTH REQUIRED OPTIONAL LETTER "R" WILL APPEAR INSTEAD OF THE FIRST DASH EXAMPLE : 77311R424T03LF

V = BLIBOX PACKAGING FOR CUSTOMER DEDICATED PART. ONLY FOR 77311-4BNV01LF

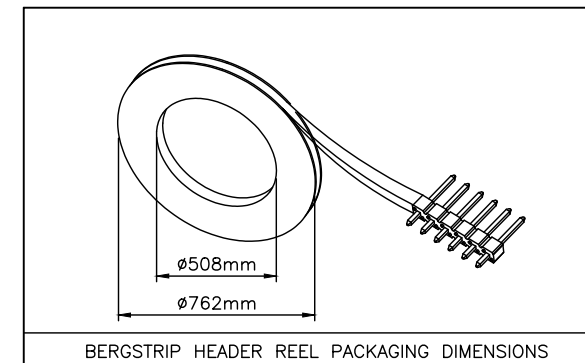
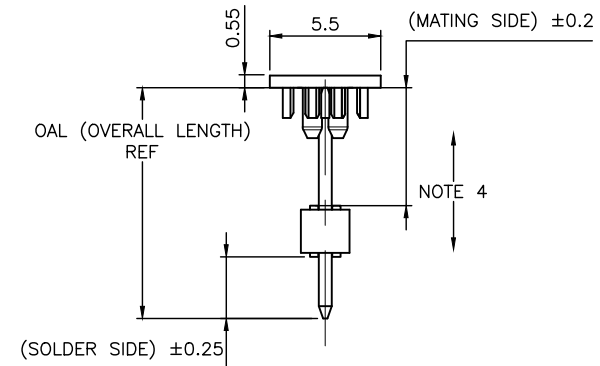
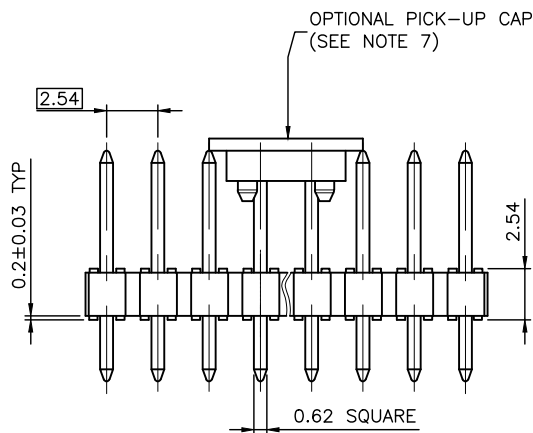
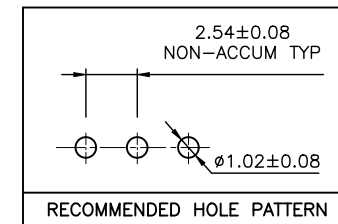
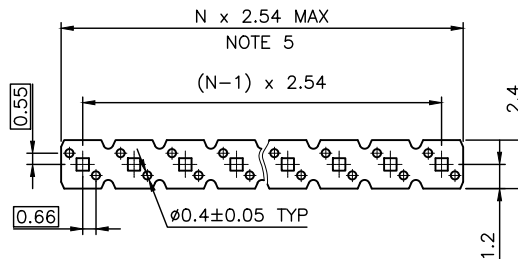

mat'l. code SEE NOTES				surface ISO 1302 ✓		tolerance ISO 406 ISO 1101		projection mm		product family BERGSTIK	
ltr	ecn	no	dr	date	tolerances unless otherwise specified		title		UNSHR.HEADER STR SR TMT		
CW	F-	38159	DDE	20.08.26	angles	linear	mm		sheet 1 of 3 size		
						.x ±0.3			77311 A3		
						.xx ±0.15	scale 5:1		type CUSTOMER Drawing		
						.xxx ±0.05					
CR	F-	28445	DDE	17.11.10	dr	D.LE	01.01.24	Amphenol FCI		dwg no	
CS	F-	29484	DDE	18.03.08	engr	JM.C	01.01.24			sheet 1 of 3 size	
CT	F-	31328	LMU	18.09.20	chr	JM.C	01.01.24			77311 A3	
CU	F-	33636	LMU	19.05.22	appd	JF.N	01.01.24			type CUSTOMER Drawing	
CV	F-	35304	LMU	19.11.04							
sheet index	revision	CW	BX	M							
		1	2	3							

PLATING

- 1 = 0.76µm GOLD/GXT ON CONTACT AREA, 2µm TIN MIN ON TAIL
- 4 = 2µm TIN MIN FULL PLATED
- 5 = 0.25µm GOLD/GXT ON CONTACT AREA, 2µm TIN MIN ON TAIL
- 8 = 0.38µm GOLD/GXT ON CONTACT AREA, 2µm TIN MIN ON TAIL
- G = 0.76µm FULL GXT
- S = 0.38µm FULL GXT
- T = 2µm TIN MIN FULL PLATED INCLUDED PIN TYP
 - 1.27µm NICKEL MIN UNDERLAYER FOR ALL PLATING VERSIONS

RETENTION FEATURES :

- 1 - PART NUMBER 77311-XXXXRXXLF: DIM "Z"=(0.99)
PART NUMBER 77311-XXXXCXXLF: DIM "Z"= 1.05MIN -1.15MAX
- 2 - PINS "A" AND "B" USED FOR RETENTION.
- 3 - DIRECTION OF RETENTION SHOWN BY ARROWS.
- 4 - ON 4 TO 36 POSITIONS HEADER; RETENTION IS IN MID POSITION OF HEADER (4 CENTRAL PINS)
- 5 - FOR RETENTION OPTION , SOLDER TAIL LENGTH TO BE 2.9 MIN UP TO 3.5 MAX.
- 6 - HOUSING MATERIAL FOR P/N 77311-4AJC03LF & 77311-TAJC03LF HIGH TEMPERATURE THERMOPLASTIC UL94V-0 COLOR : NATURAL

PLATING SPECIFICATIONS :

- 7 - ONLY FOR PLATING 1XX, 8.0MM GOLD / GXT PLATING AREA FROM PIN TYPE ON MATING SIDE

RETENTION FEATURES

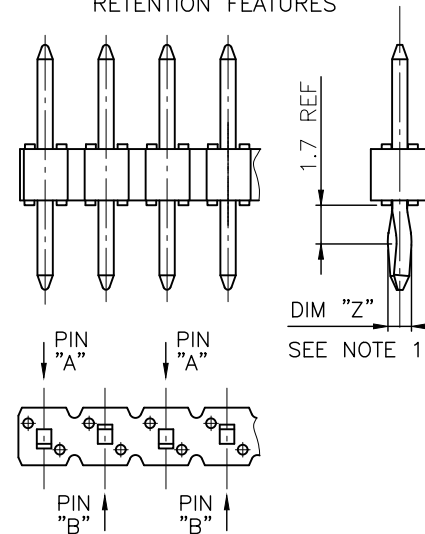

1.7 REF
DIM "Z"
SEE NOTE 1

Amphenol FCI
FCIconnect.com

Copyright FCI

mat'l. code		surface		tolerance		projection		product family	
		ISO 1302		ISO 406 ISO 1101		mm		BERGSTIK	
ltr	ecn no	dr	date	tolerances unless otherwise specified		title			
BU	B-20596	AMA	15.03.30			UNSHR.HEADER			
BV	F-22085	LMU	15.10.05	angles	linear	STR SR TMT			
BW	F-22100	AMA	15.10.08			scale N/A			
BX	F-26241	LMU	17.03.01	dr	D.LE	01.01.24	dwg no		sheet 2 of 3
				engr	JM.C	01.01.24	77311		A3
BS	B-20169	BVE	15.02.12	chr	JM.C	01.01.24	type		CUSTOMER Drawing
BT	B-20497	BVE	15.03.18	appd	JF.N	01.01.24			
sheet index	revision sheet								



PRODUCTS SPECIFICATIONS			
PIN STYLE	MATING	SOLDER	OAL
01	5.84	2.41	10.8
02	5.84	3.42	11.8
03	5.72	5.09	13.35
05	5.72	10.14	18.4
08	5.72	17.78	26.04
11	5.72	5.94	14.20
15	8.51	2.55	13.6
18	5.84	3.05	11.43
19	12.83	3.03	18.4
20	15.37	3.04	20.95
22	7.75	3.05	13.35
24	6.75	2.9	12.2
25	8.51	3.18	14.22
27	6.6	2.65	11.8
26	15.57	2.84	20.95
29	17.5	3.46	23.5
32	10.3	3.05	15.9
38	5.84	3.82	12.2
39	11.2	3.05	16.8
46	8.08	2.98	13.6
54	8.08	3.81	14.43
58	14.47	3.05	20.06
62	13.5	3.05	19.09
70	6.54	3.50	12.57
83	20.46	3.00	26.00
85	5.72	8.51	16.76
87	6.98	3.05	12.57
91	5.6	10.21	18.35
92	5.65	12.76	20.95
93	6.00	4.81	13.35
94	15.60	3.20	21.25
95	10.00	8.45	20.95
96	10.95	3.05	16.55
97	9.00	3.55	15.09
98	3.00	1.35	6.84
99	24.00	3.05	29.50
AA	5.72	15.24	23.50
AB		N/A	2.79

NOTE 7

PRODUCTS SPECIFICATIONS			
PIN STYLE	MATING	SOLDER	OAL
AC	7.21	3.05	12.80
AD	17.53	3.43	23.50
AE	4.99	2.80	10.33
AF	5.72	3.05	11.30
AG	5.84	4.95	13.33
AH	14.31	3.20	20.05
AJ	8.90	3.40	14.85
AK	25.06	3.00	30.80
AL	3.30	3.30	9.14
AM	9.26	3.05	14.85
AN	7.60	4.40	14.47
AP	7.80	3.30	13.60
AR	18.86	2.41	23.81
AS	11.91	1.45	15.90
AT	4.60	4.60	11.61
AU	12.10	3.10	17.70
AV	6.30	6.30	15.10
AW	9.16	1.80	13.50
AX	5.08	2.43	10.05
AY	7.49	3.47	13.50
BA	8.08	2.75	13.37
BB	10.80	2.15	15.50
BC	8.08	3.81	14.43
BD	10.10	2.16	14.80
BE	13.65	2.41	18.60
BF	2.54	5.32	10.40
BG	4.98	1.85	9.23
BH	4.69	2.41	9.50
BJ	7.21	6.15	15.90
BK	6.86	2.65	12.05
BL	17.70	3.25	23.50
BM	10.96	3.70	16.20
BN	19.46	3.00	25.00
BP	8.80	3.20	14.50
BR	19.46	4.00	26.00
BS	5.72	11.05	19.30
BT	8.50	5.36	16.40
BU	3.80	3.80	10.14
BV	5.08	2.79	10.40
BW	7.36	2.30	12.20

NOTE 6

PRODUCTS SPECIFICATIONS			
PIN STYLE	MATING	SOLDER	OAL
BX	2.67	3.43	8.60
BY	11.90	3.05	17.50

mat'l. code		surface		tolerance		projection		product family	
H F-29484 DDE 18.03.08		ISO 1302		ISO 406 ISO 1101				BERGSTIK	
J F-31328 LMU 18.09.20		tolerances unless otherwise specified		angles		mm		title	
K F-33636 LMU 19.05.22				linear				UNSHR.HEADER STR SR TMT	
L F-35304 LMU 19.11.04		dr		A.MA		15.10.08		dwg no	
M F-38159 DDE 20.08.26		engr		L.MU		15.10.08		sheet 3 of 3 size	
G F-28445 DDE 17.11.10		appd		chr		J.CO		77311 A3	
				ASO		15.10.08		type CUSTOMER Drawing	
sheet index		revision sheet							

Copyright FCI
 Amphenol FCI
 FCconnect.com