

Enclosures & Components

Systemkit 12K

Modern designed EMC sub rack with a large selection of assembly options.

System Solutions

Integrated Systems Chassis Platforms Backplanes Embedded Products Cabinets

Enclosures & Components

Enclosures Front Panels Handles

Rotary Switches

Switches/Encoders Knobs LEDs

ELMA
Your Solution Partner

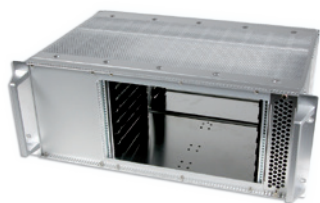

4.1 Systemkit 12K Overview

A | 4_3

4.1.1 Basic Set-up Overview

A | 4_7

4.2 Step A: Applications

A | 4_9

4.2.1 CPCI, VME, VME64x 19" Basic Set

A | 4_9

4.2.2 Internal Extrusion

A | 4_10

4.3 Step B: Applications Range

A | 4_11

4.3.1 Height Extrusions for 19" Version

A | 4_11

4.3.2 Height Extrusions for 19" Version (for Telescopic Rails)

A | 4_12

4.4 Step C: Assembly Options

A | 4_13

4.4.1 Reduction Kit $\frac{1}{3}$ U + $\frac{2}{3}$ U for Front Mounting, Solid

A | 4_13

4.4.2 Reduction Kit $\frac{1}{3}$ U + $\frac{2}{3}$ U for 60 mm Recessed Mounting

A | 4_13

4.4.3 Reduction Kit $\frac{1}{2}$ U + $\frac{1}{2}$ U for Front Mounting

A | 4_14

4.4.4 Reduction Kit $\frac{1}{2}$ U + $\frac{1}{2}$ U for 60 mm Recessed Mounting

A | 4_14

4.4.5 Bottom / Top Panel Solid

A | 4_15

4.4.6 Bottom / Top Panel Perforated

A | 4_15

4.5 Step D: Assembly Accessories

A | 4_16

4.5.1 Rear I/O Card Mounting

A | 4_16

4.5.2 Front Sub Divisions

A | 4_16

4.5.3 Horizontal Card Mounting Kits

A | 4_19

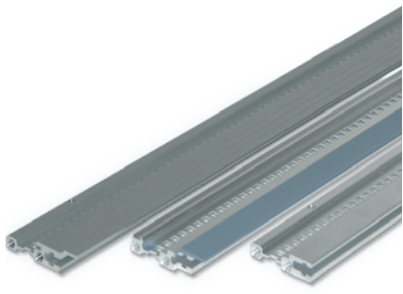

4.6 Step E: EMC Shielding

A | 4_21

4.6.1 EMC-Set for Bottom/Top Panel, Depth (Advanced EMC-level) A | 4_21

4.6.2 EMC-Set for Bottom / Top Panel, Width (Advanced EMC-level) A | 4_21

4.6.3 Extrusion for Recessed EMC Mounting (Basic EMC-level) A | 4_22

4.6.4 EMC-Gasket for Height Extrusion, Front Panel (Advanced EMC-level) A | 4_22

4.6.5 EMC Contact Strips (Advanced EMC-level) A | 4_22

4.7 Step F: General Accessories

A | 4_23

4.7.1 Mounting Chassis A | 4_23

4.7.2 Card Guides A | 4_24

4.7.3 Plug-in Units A | 4_29

4.7.4 Front Panels A | 4_36

4.7.5 Telescopic Rails A | 4_40

4.8 Step G: Extrusions

A | 4_41

4.8.1 Front Extrusions A | 4_41

4.8.2 Internal Extrusions A | 4_41

4.8.3 Height Extrusions A | 4_44

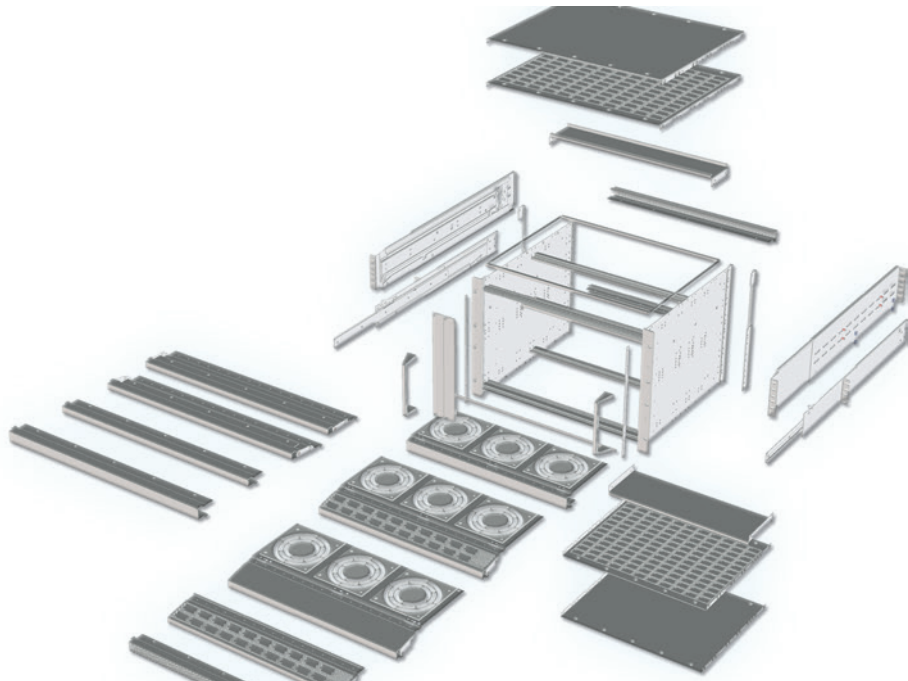

4.1 Systemkit 12K Overview

The origin of the Systemkit 12K is our highly successful type 12. The Systemkit has several advantages, already in the standard version:

- Choose between a VME, a VME64x or a CPCI application
 - Possibility for Rear I/O card mounting
 - A basic EMC level is attained with the basic version (without additional EMC parts)
 - Choose from the most common case heights and depths as standard version
 - New sets have been created to facilitate the order of complementary parts
- and last but not least:**
- The Systemkit 12K gives the ideal platform basis for modified standards and **customised products**

CPCI/VME/VME64X

The first step when ordering your system is to choose the application. This can be either CPCI, VME64x or VME. Some of the parts shown in this catalogue are for CPCI, VME64x or for VME only. Whenever there is **no indication** on neither CPCI, VME64x or VME the part can be **used for all applications**.

Modified Standards

Examples for **possible modifications** are:

- Other dimensions for mounting different card depth
- Combination of rear I/O and recessed mounting
- Other materials and/or colours
- For more information contact our sales support

EMC

"Electromagnetic compatibility is the ability of a system to operate in the intended environment without causing or suffering unacceptable degradation of performance due to unintentional electromagnetic radiation or response." The EMC characteristics of a system therefore consist of an appropriate immunity from interference (noise immunity) and a limited emission of interference (noise emission).

Elma's EMC concept describes three levels of electromagnetic shielding performance (Performance Level). The attenuation levels will simplify the selection of sub racks for the user. Test setup: The first measurement E1 is without the enclosure. The next measurement E2 is made with the transmitting antenna installed inside the enclosure. The difference between the received signal without and with the enclosure represents the shielding effectiveness in dB.

Performance Level	30 - 230 MHz	230 - 1000 MHz	1000 - 2000 MHz
1 / Elma: Basic level	20 dB	10 dB	0 dB
2 / Elma: Advanced level	40 dB	30 dB	20 dB
3 / Elma: Superior level	60 dB	50 dB	40 dB

The standard configuration will provide you with a basic EMC level. If you require an advanced EMC level for your system, you need to order **additional EMC parts**. Throughout the catalogue we have put these EMC parts **in a yellow table**.

RoHS - the Systemkit 12K is 100% RoHS Compliant

"Restriction of the use of certain hazardous substances in electrical and electronic equipment"

Elma Electronic AG is fully aware of its responsibilities towards its customers and the environment and therefore started a corresponding project which is finished in the meantime.

The new sub rack family Systemkit 12K fulfils the directive 2002/95/EG (RoHS)!

After our present knowledge all parts found in this catalogue do not contain materials, whose placing on the market is forbidden in accordance with RoHS. So it is specially mentioned that for the optimisation of the corrosion and wear protection as well as the improvement of the electrical conductivity as basis of an optimal EMC protection of the electronics the metal surfaces are electro-plated. In co-operation with proven specialised experts we have analysed different RoHS conformal procedures which fulfils our high requirements concerning quality, EMC, corrosion protection and optics.

The procedure for the RoHS compliant surface treatment, selected by us, obtained outstanding results with all tests and examinations. It is particularly worth mentioning that with the climatic test in accordance with IEC 61587-1 the highest requirement (Performance level C3 and A3) were successfully fulfilled by our products.

Substantial results of the surface treatment:

- Optically identical surfaces to the past procedures (colourless)
- High EMC protection
- Optimal adhesion for coloured surface coatings
- Fulfils the highest performance level (C3, A3) of climatic tests in accordance to IEC 61587-1 (*)

(*) acc. to IEC 61587-1:

Performance Level: C3 (Cold, dry heat and damp heat, cyclic)

- Example of use: Extreme climatic impact (eg. outdoor, tropical environment) with temperature between -40°C and +85°C, relative humidity of 20% to 95%, no condensation

Performance Level: A3 (Industrial atmosphere)

- Example of use: strong concentration of toxic substances and exposure through maritime climate at the same time (eg. off-shore chemical engineering, oil platform) with concentration of acc. to IEC 60654-4:
 - SO₂ at average: 5 cm³/m³, max. 15 cm³/m³
 - H₂S at average: 10 cm³/m³, max. 50cm³/m³

Climatic and Mechanical Tests

The Systemkit 12K fulfils the following test according to:

- Vibration EN 60068-2-6
- Shock EN 60068-2-27
- Dry Heat EN 60068-2-2
- Damp heat, cyclic EN 60068-2-30
- Cold EN 60068-2-1
- Salt Spray test DIN 50021

The functionality of the sub rack was ensured during all tests.

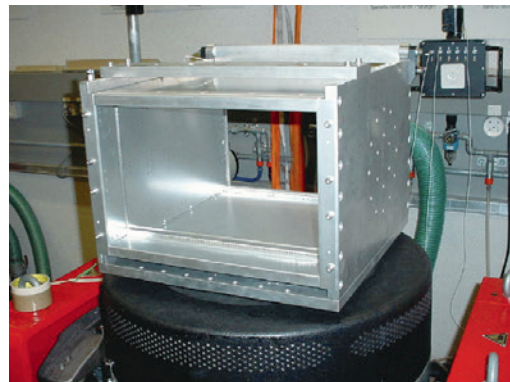

Detail information to climatic and mechanical tests:

- **Vibration** EN 60068-2-6

Resonance search:

Frequency: 3 Hz to 100Hz, Sweeprate: 1 Oct/min.
1 Cycle / Axle (X, Y, Z)

Resonance stay: (Z: 50.7 Hz, Y = 89.5Hz, X = 70.9Hz)

10 m/s ²	15 min
30 m/s ²	2 min

- **Shock** EN 60068-2-27

Shockform: Halfsinus	Acceleration: 50 m/s ²	Duration: 11 ms
Number of Shocks: 3 per Axle		Total: 18 Shocks

- **Dry heat** EN 60068-2-2

Temperature: +85 °C	Duration: 16 h
---------------------	----------------

- **Damp heat, cyclic** EN 60068-2-30

Upper temperature: +55 °C	Duration: 9 h	Damp: 95 % r.H.
Lower temperature: +25 °C	Duration: 9 h	Damp: 95 % r.H.
Ramp: In 3h from +25 °C to +55 °C and in 3 h back again.		
Number of cycles: 2	Time: 24 h	Total time: 48 h

- **Cold** EN 60068-2-1

Temperature: -40 °C	Duration: 16 h
---------------------	----------------

- **Salt Spray test** DIN 50021

Salt concentration: 50 g/l	Duration: 16 h	Temperature: +35 °C
----------------------------	----------------	---------------------

Configuration



4.2 Step A: Application

- Basic Set CPCI, VME, VME64X
- Internal Extrusion

4.3 Step B: Application Range

- Height Extrusion 19"



4.4 Step C: Assembly Options

- Reduction Kit $\frac{1}{2} + \frac{1}{2}$
- Reduction Kit $\frac{1}{3} + \frac{2}{3}$
- Front or Recessed Mounting
- Bottom/Top Panel Solid and Perforated



4.5 Step D: Assembly Accessories

- Rear I/O Card Mounting
- Front Sub Divisions
- Horizontal Mounting Kits
- Drive Modules

4.6 Step E: EMC Shielding

4.7 Step F: General Accessories

4.8 Step G: Extrusions

4.1.1 Basic Set-up Overview

CPCI (IEEE1101.10/IEEE1101.11) Standard Configurations**

Height	3 U		4 U			289 mm
	289 mm	400 mm	289 mm	400 mm	500 mm	
Depth	19"	19"	19"	19"	19"	19"
Width	19"	19"	19"	19"	19"	19"
Part-No.	12K001	12K041	12K002	12K003	12K004	12K008
For card size	3 U	3 U	3 U	3 U	3 U	3 U / 6 U
For card depth	160 mm	160 mm 220 mm	160 mm	160 mm 220 mm	160 mm 220 mm	160 mm
Rear I/O card depth*	80 mm	-	80 mm	80 mm	80 mm	80 mm
Max. Slot	21	21	21	21	21	21
Front mounting	possible	possible	possible	possible	possible	possible
Recessed mounting	-	-	possible	possible	possible	possible (3 U)
Height reduction	-	-	possible	possible	possible	possible (3 U)
Base material	aluminium	aluminium	aluminium	aluminium	aluminium	aluminium
Surface treatment	conductive	conductive	conductive	conductive	conductive	conductive
Possible EMC level	advanced	advanced	advanced	advanced	advanced	advanced

VME (IEEE1101.10/IEEE1101.11) Standard Configurations**

Height	3 U		4 U				291 mm
	291 mm	400 mm	291 mm	371 mm	400 mm	500 mm	
Depth	19"	19"	19"	19"	19"	19"	19"
Width	19"	19"	19"	19"	19"	19"	19"
Part-No.	12K023	12K024	12K025	12K026	12K027	12K028	12K029
For card size	3 U	3 U	3 U	3 U	3 U	3 U	3 U / 6 U
For card depth	160 mm	160 mm 220 mm	160 mm 220 mm	160 mm 220 mm	160 mm 220 mm	160 mm 220 mm	160 mm 220 mm
Rear I/O card depth*	-	-	-	160 mm	160 mm	160 mm	-
Max. Slot	21	21	21	21	21	21	21
Front mounting	possible	possible	possible	possible	possible	possible	possible
Recessed mounting	-	-	possible	-	possible	possible	possible (3 U)
Height reduction	-	-	possible	possible	possible	possible	possible (3 U)
Base material	aluminium	aluminium	aluminium	aluminium	aluminium	aluminium	aluminium
Surface treatment	conductive	conductive	conductive	conductive	conductive	conductive	conductive
Possible EMC level	advanced	advanced	advanced	advanced	advanced	advanced	advanced

VME (IEC 60297) Standard Configurations**

Height	3 U			4 U				291 mm
	291 mm	400 mm	500 mm	291 mm	371 mm	400 mm	500 mm	
Depth	19"	19"	19"	19"	19"	19"	19"	19"
Width	19"	19"	19"	19"	19"	19"	19"	19"
Part-No.	12K019	12K020	12K044	12K038	12K005	12K006	12K007	12K039
For card size	3 U	3 U	3 U	3 U	3 U	3 U	3 U	3 U / 6 U
For card depth	160 mm	160 mm 220 mm	160 mm 220 mm	160 mm 220 mm	160 mm 220 mm	160 mm 220 mm	160 mm 220 mm	160 mm 220 mm
Rear I/O card depth*	-	-	-	-	160 mm	160 mm	160 mm	-
Max. Slot	21	21	21	21	21	21	21	21
Front mounting	possible	possible	possible	possible	possible	possible	possible	possible
Recessed mounting	-	-	-	possible	-	possible	possible	possible (3 U)
Height reduction	-	-	-	possible	possible	possible	possible	possible (3 U)
Base material	aluminium	aluminium	aluminium	aluminium	aluminium	aluminium	aluminium	aluminium
Surface treatment	conductive	conductive	conductive	conductive	conductive	conductive	conductive	conductive
Possible EMC level	advanced	advanced	advanced	advanced	advanced	advanced	advanced	advanced

*Rear I/O possible, when front cards 160 mm, only. No recessed mounting possible in combination with rear I/O

Datasheet

6 U		7 U			9 U	
400 mm	500 mm	289 mm	400 mm	500 mm	400 mm	500 mm
19"	19"	19"	19"	19"	19"	19"
12K042	12K043	12K011	12K012	12K013	12K021	12K022
3 U / 6 U	3 U / 6 U	3 U / 6 U	3 U / 6 U	3 U / 6 U	3 U / 6 U	3 U / 6 U
160 mm	160 mm	160 mm	160 mm	160 mm	160 mm	160 mm
220 mm	220 mm	220 mm	220 mm	220 mm	220 mm	220 mm
-	-	80 mm	80 mm	80 mm	80 mm	80 mm
21	21	21	21	21	21	21
possible	possible	possible	possible	possible	possible	possible
possible (3 U)	possible (3 U)	possible	possible	possible	possible	possible
possible (3 U)	possible (3 U)	possible	possible	possible	possible	possible
aluminium	aluminium	aluminium	aluminium	aluminium	aluminium	aluminium
conductive	conductive	conductive	conductive	conductive	conductive	conductive
advanced	advanced	advanced	advanced	advanced	advanced	advanced

6 U		7 U				9 U	
400 mm	500 mm	291 mm	371 mm	400 mm	500 mm	400 mm	500 mm
19"	19"	19"	19"	19"	19"	19"	19"
12K030	12K031	12K032	12K033	12K034	12K035	12K036	12K037
3 U / 6 U	3 U / 6 U	3 U / 6 U	3 U / 6 U	3 U / 6 U	3 U / 6 U	3 U / 6 U	3 U / 6 U
160 mm	160 mm	160 mm	160 mm	160 mm	160 mm	160 mm	160 mm
220 mm	220 mm	220 mm	220 mm	220 mm	220 mm	220 mm	220 mm
-	-	-	160 mm	160 mm	160 mm	160 mm	160 mm
21	21	21	21	21	21	21	21
possible	possible	possible	possible	possible	possible	possible	possible
possible (3 U)	possible (3 U)	possible	-	possible	possible	possible	possible
possible (3 U)	possible (3 U)	possible	possible	possible	possible	possible	possible
aluminium	aluminium	aluminium	aluminium	aluminium	aluminium	aluminium	aluminium
conductive	conductive	conductive	conductive	conductive	conductive	conductive	conductive
advanced	advanced	advanced	advanced	advanced	advanced	advanced	advanced

6 U		7 U				9 U	
400 mm	500 mm	291 mm	371 mm	400 mm	500 mm	400 mm	500 mm
19"	19"	19"	19"	19"	19"	19"	19"
12K009	12K010	12K040	12K014	12K015	12K016	12K017	12K018
3 U / 6 U	3 U / 6 U	3 U / 6 U	3 U / 6 U	3 U / 6 U	3 U / 6 U	3 U / 6 U	3 U / 6 U
160 mm	160 mm	160 mm	160 mm	160 mm	160 mm	160 mm	160 mm
220 mm	220 mm	220 mm	220 mm	220 mm	220 mm	220 mm	220 mm
-	-	-	160 mm	160 mm	160 mm	160 mm	160 mm
21	21	21	21	21	21	21	21
possible	possible	possible	possible	possible	possible	possible	possible
possible (3 U)	possible (3 U)	possible	-	possible	possible	possible	possible
possible (3 U)	possible (3 U)	possible	possible	possible	possible	possible	possible
aluminium	aluminium	aluminium	aluminium	aluminium	aluminium	aluminium	aluminium
conductive	conductive	conductive	conductive	conductive	conductive	conductive	conductive
advanced	advanced	advanced	advanced	advanced	advanced	advanced	advanced

**Other configurations on request as modified standard, please contact our sales support

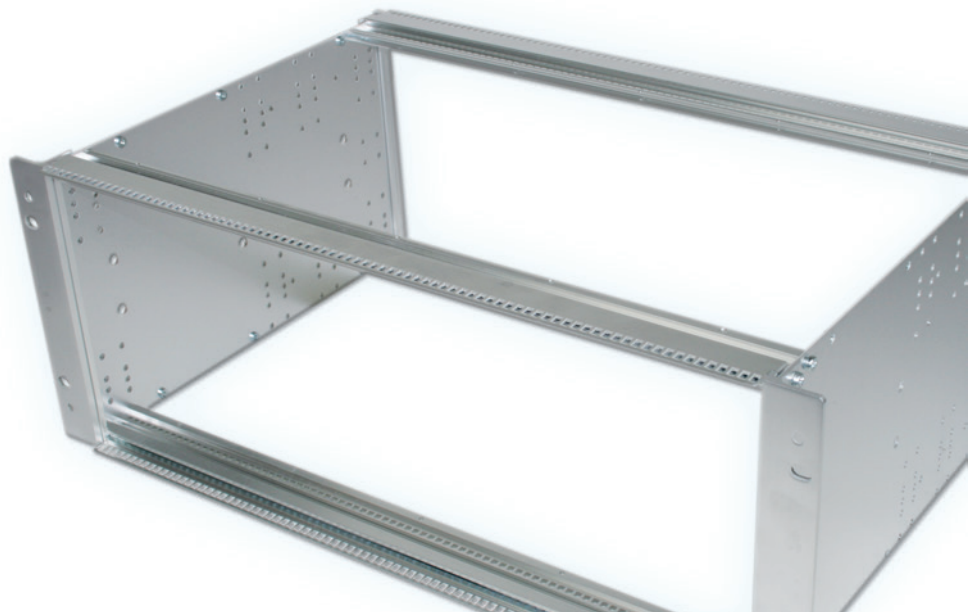

4.2 Step A: Applications

4.2.1 CPCI, VME, VME64x 19" Basic Set

- **Scope of delivery:**

- 2 side panels
- 4 front extrusions
- 4 tapped strips M2.5
- 1 set assembly material (16 cylinder head screws M4 x 10, Torx T20)



4.2.1.1 CPCI Applications (IEEE1101.10/IEEE1101.11)

	3 U	4 U	6 U	7 U	9 U
Depth	132.5 mm	177.0 mm	265.9 mm	310.3 mm	399.2 mm
289 mm	12K001	12K002	12K008	12K011	-
400 mm	12K041	12K003	12K042	-	12K021
500 mm	-	12K004	-	-	-

4.2.1.2 VME64x Applications (IEEE1101.10/IEEE1101.11)

	3 U	4 U	6 U	7 U	9 U
Depth	132.5 mm	177.0 mm	265.9 mm	310.3 mm	399.2 mm
291 mm	12K023	12K025	12K029	12K032	-
400 mm	12K024	12K027	12K030	12K034	12K036
500 mm	-	-	12K031	12K035	12K037

4.2.1.3 VME Applications (IEC60297)

	3 U	4 U	6 U	7 U	9 U
Depth	132.5 mm	177.0 mm	265.9 mm	310.3 mm	399.2 mm
291 mm	12K019	12K038	12K039	12K040	-
371 mm	-	12K005	-	-	-
400 mm	12K020	12K006	12K009	12K015	12K017
500 mm	12K044	12K007	12K010	12K016	12K018

4.2.2 Internal Extrusion

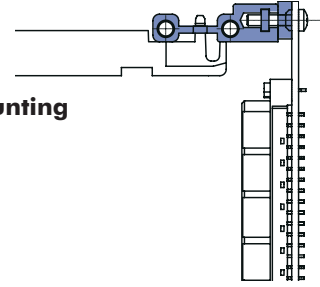

4.2.2.1 Internal Extrusion for Insulated Backplane Mounting

- **Scope of delivery:**
 - 2 internal extrusions
 - 2 tapped strips M2.5
 - 2 insulating strips
 - Assembly material (8 cylinder head screws M4 x 10, Torx T20)



Description	Part-No.
Insulated mounting of backplane	12K506

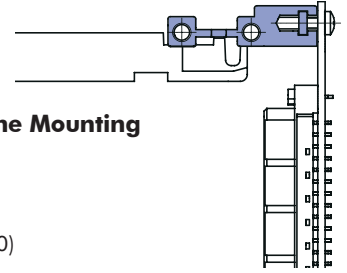

4.2.2.2 Internal Extrusions for Non-Insulated Backplane Mounting

- **Scope of delivery:**
 - 2 internal extrusions
 - 2 tapped strips M2.5
 - Assembly material (8 cylinder head screws M4 x 10, Torx T20)



Description	Part-No.
Non-insulated mounting of backplane	12K507

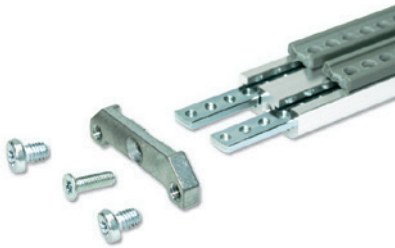

4.2.2.3 Double Extrusion for Insulated Backplane Mounting

- For 6 U cards only
- Stiffener for VME Monolithic
- Fixing for J1 and J2 Backplanes
- **Scope of delivery:**
 - 1 double extrusion
 - 2 tapped strips
 - 2 insulating strips
 - Assembly material (8 x M4 x 6, Torx T20, 2 x M3 x 10, Torx T20, 2 x adapter)

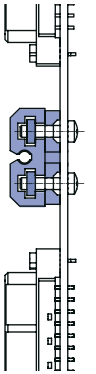

Description	Part-No.
1 set double extrusion for insulated backplane mounting	12K508

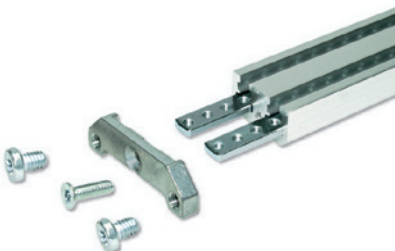

4.2.2.4 Double Extrusion for Non-Insulated Backplane Mounting

- For 6 U cards only
- Stiffener for VME Monolithic
- Fixing for J1 and J2 Backplanes
- **Scope of delivery:**
 - 1 double extrusion
 - 2 tapped strips M2.5
 - Assembly material (8 x M4 x 6, Torx T20, 2 x M3 x 10, Torx T20, 2 x adapter)

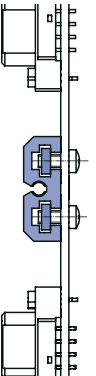

Description	Part-No.
1 set double extrusion for non-insulated backplane mounting	12K509



4.3 Step B: Applications Range

4.3.1 Height Extrusions for 19" Version

- Not suitable for telescopic rail mounting (see 4.3.2)
- **Scope of delivery:**
 - 2 height extrusions 19" (front)
 - 2 height extrusions (rear)
- Handles, see below
- EMC-gaskets see 4.6.4

4.3.1. Height Extrusions for 19" Version

Height:	3 U	4 U	6 U	7 U	9 U
Part-No.:	12K200	12K201	12K202	12K203	12K204



4.2.1.1 Aluminium Handle 9 mm (Anodised)

- **Scope of delivery:**
 - 1 handle for height extrusion
 - 2 countersunk screws M4 x 10, Torx T20
- Per sub rack 2 handles have to be ordered

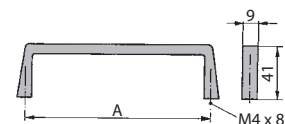

Case size:	3 U	4 U	6 U	7 U	9 U
Handle size (A):	3 U (88.9 mm)	4 U (133.4 mm)	6 U (222.3 mm)	4 U (133.4 mm)	6 U (222.3 mm)
Part-No.:	60-573	60-574	60-576	60-574	60-576





4.3.1.2 Die Cast Aluminium Handle (Wet painted RAL 9006)

- **Scope of delivery:**
 - 1 handle for height extrusion
 - 2 countersunk screws M4 x 10, Torx T20
- Per sub rack 2 handles have to be ordered

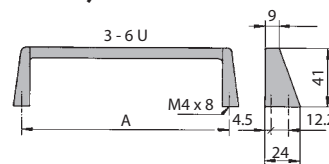

Case size:	3 U	4 U	6 U	7 U	9 U
Handle size (A):	3 U (88.9 mm)	4 U (133.4 mm)	6 U (222.3 mm)	4 U (133.4 mm)	6 U (222.3 mm)
Part-No.:	60-563	60-564	60-566	60-564	60-566

4.3.2 Height Extrusions for 19" Version (for Telescopic Rails)

- Suitable for telescopic rail mounting
- **Scope of delivery:**
 - 2 height extrusions (19" front)
 - 2 height extrusions (rear)
 - 2 die cast aluminium handles
 - Assembly material (4 countersunk screws M4 x 10, Torx T20)
- Telescopic rails, see below
- EMC-gaskets see 4.6.4



4.3.2 Height Extrusions for 19" Version (for Telescopic Rails)

Height:	3 U	6 U
Part-No.:	12K400	12K402

Other heights available on request



4.3.2.1 Telescopic Rails, Set (Load Capacity up to 60 kg/Pair)

- Telescopic rails, suitable for all heights
- **Scope of delivery:**
 - 2 telescopic rails
 - Mounting bracket and assembly material for mounting into cabinet and on module

Max. withdraw	Usable depth		Part-No.
	min.	max.	
511.2 mm	463 mm	681.8 mm	65-051
596.4 mm	564.6 mm	783.4 mm	65-052
719.6 mm	666.2 mm	885.0 mm	65-053

Rugged telescopic rails, load capacity up to 90 kg/pair available on request



4.4 Step C: Assembly Options

4.4.1 Reduction Kit $\frac{1}{3}$ U + $\frac{2}{3}$ U for Front Mounting, Solid

- Material: Aluminium 1.5 mm, conductive, depth independent (to be used in conjunction with the bottom/top panel)
- For 160 mm card depth, for 4 U case (eurocard) / for 7 U case (double eurocard)
- **Scope of delivery:**
 - 1 adapter top ($\frac{1}{3}$ U), 1 adapter bottom ($\frac{2}{3}$ U) incl. fan panel
 - 1 set assembly material (6x M3 x 8, Torx T10/ 4x M4 x 10, Torx T20)



4.4.1 Reduction Kit $\frac{1}{3}$ U + $\frac{2}{3}$ U for Front Mounting, Solid

Description	Part-No.
Reduction kit solid incl. fan panel	12K732

4.4.1.1 Additional fan plate

- For easy access and maintenance of the fans
- **Scope of delivery:**
 - 1 fan plate
 - 8 milled edge screws M3 x 5, Torx T10

Description	Part-No.
Additional fan plate incl. 1 set assembly material	12K737

4.4.2 Reduction Kit $\frac{1}{3}$ U + $\frac{2}{3}$ U for 60 mm Recessed Mounting

- Material: Aluminium 1.5 mm, conductive, depth independent (to be used in conjunction with the bottom/top panel)
- For 60 mm recessed only, for 160 mm card depth, for 4 U case (eurocard) / for 7 U case (double eurocard)
- **Scope of delivery:**
 - 1 adapter top ($\frac{1}{3}$ U), 1 adapter bottom ($\frac{2}{3}$ U) incl. fan panel
 - 1 set assembly material (6x M3 x 8 Torx T10, 4x M4 x 10 Torx T20)



4.4.2 Reduction Kit $\frac{1}{3}$ U + $\frac{2}{3}$ U for 60 mm Recessed Mounting

Part-No. perforated*	Part-No. solid
12K500	12K501

* only bottom part ($\frac{2}{3}$ U) is perforated

4.4.2.1 Additional fan plate

- For easy access and maintenance of the fans
- **Scope of delivery:**
 - 1 fan plate
 - 8 milled edge screws M3 x 5, Torx T10

Description	Part-No.
Additional fan plate incl. 1 set assembly material	12K737

4.4.3 Reduction Kit 1/2 U + 1/2 U for Front Mounting

- Material: Aluminium 1.5 mm, conductive, depth independent (to be used in conjunction with the bottom/top panel)
- For 4 U case (eurocard) / for 7 U case (double eurocard)
- **Scope of delivery:**
 - 1 adapter (1/2 U)
 - No assembly material needed
- Per sub rack 2 pcs. (4 pcs. with Rear I/O) have to be used (ordered)



4.4.3 Reduction Kit 1/2 U + 1/2 U for Front Mounting

Part-No. solid
12K710
Perforated version available on request

4.4.4 Reduction Kit 1/2 U + 1/2 U for 60 mm Recessed Mounting

- Material: Aluminium 1.5 mm, conductive, depth independent (to be used in conjunction with the bottom/top panel)
- For 4 U case (eurocard) / for 7 U case (double eurocard)
- **Scope of delivery:**
 - 1 adapter (1/2 U)
 - 1 set assembly material (2 cylinder head screws M4 x 10, Torx T20)
- Per sub rack 2 pcs. have to be used (ordered)
- ! the depth independent 1/2 U adapter are to be used in conjunction with the bottom/top panel



4.4.4 Reduction Kit 1/2 U + 1/2 U for 60 mm Recessed Mounting

Part-No. solid
12K730
Perforated version available on request

4.4.5 Bottom / Top Panel Solid

- Material: Aluminium 1.5 mm, conductive
- EMC-level: basic (for an advanced EMC-level use EMC-sets, see 4.6)
- **Scope of delivery:**
 - 1 bottom/top panel solid
 - 1 set assembly material (18 cylinder head screws M3 x 6 Torx T10)



4.4.5 Bottom / Top Panel Solid

Depth	Part-No.
289 mm	12K746
291 mm	12K720
371 mm	12K722
400 mm	12K723
500 mm	12K724

4.4.6 Bottom / Top Panel Perforated

- Material: Aluminium 1.5 mm, conductive
- EMC-level: basic (for an advanced EMC-level use EMC-sets, see 4.6)
- **Scope of delivery:**
 - 1 bottom/top panel perforated
 - 1 set assembly material (18 cylinder head screws M3 x 6 Torx T10)

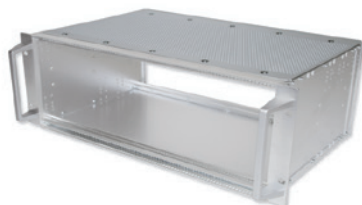

4.4.6 Bottom / Top Panel Perforated

Depth	Part-No.
289 mm	12K749
291 mm	12K725
400 mm	12K728
500 mm	12K729



4.5 Step D: Assembly Accessories

4.5.1 Rear I/O Card Mounting

- For 80 mm card depth (CPCI), for 160 mm card depth (VME & VME64x)
- **Scope of delivery:**
 - 2 internal extrusions for rear I/O card mounting
 - Assembly material (4 cylinder head screws M4 x 10 Torx T20)

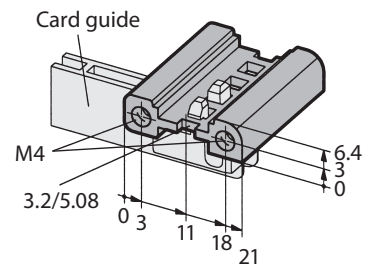

4.5.1 Rear I/O Card Mounting



Description	Part-No.
Internal extrusions for rear I/O card mounting	12K504

4.5.2 Front Sub Divisions

4.5.2.1 EMC Front Sub Division Horizontal for 84 HP System

- Advanced EMC-level
- For card guides be applied on upper and lower card cage side

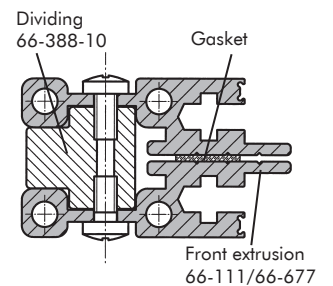

4.5.2.1 EMC Front Sub Division Horizontal for 84 HP System

- **Scope of delivery:**
 - 2 front extrusions
 - 1 EMC-gasket
 - 3 dividings
 - 1 set assembly material (8 cylinder head screws M4 x 10 Torx T20
6 cylinder head screws M3 x 6 Torx T10)
 - 2 tapped strips M2.5

Part-No. VME	Part-No. CPCI/VME64x
63K837-84	63K837-85

4.5.2.2 EMC Front Sub Division Horizontal IEC for Card Guides

- For sub division of front or rear
- Card guides can be applied
- Superior EMC-level
- Only one special extrusion needed
- Easy and quick assembly
- Cost effective solution
- Delivered in kit form
- Usable width: 84 HP
- Other sizes available on request
- **Scope of delivery:**
 - 1 front double extrusion IEC-Special clear passivated
 - 2 tapped strips M2.5
 - 4 Torx cylinder head screws M4 x 10 (T20)
- For HF spring see 4.5.2.4.1
- For EMC contact strips see 4.5.2.4.2

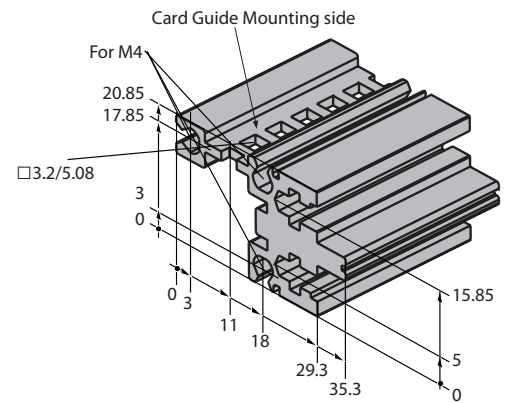

4.5.2.2 EMC Front Sub Division Horizontal IEC

Description	Part-No.
EMC front sub division horizontal IEC for card guides	63K837-24



4.5.2.3 EMC Front Sub Division Horizontal IEC

- For sub division of front or rear
- Without possibility of using card guides
- Superior EMC-level
- Only one special extrusion needed
- Easy and quick assembly
- Cost effective solution
- Delivered in kit form
- Usable width: 84 HP
- Other sizes available on request
- **Scope of delivery:**
 - 1 front double extrusion IEC-Special clear passivated
 - 2 tapped strips M2.5
 - 4 Torx cylinder head screws M4 x 10 (T20)
- For HF spring see 4.5.2.4.1
- For EMC contact strips see 4.5.2.4.2

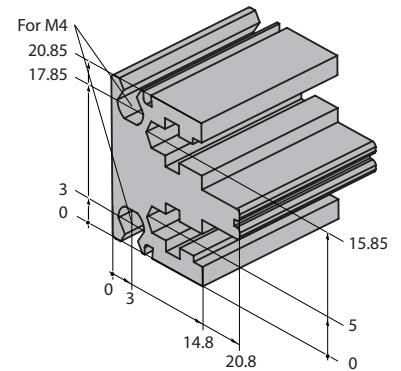

4.5.2.3. EMC Front Sub Division Horizontal IEC

Description	Part-No.
EMC front sub division horizontal IEC	63K837-22



4.5.2.4 EMC Front Sub Division Horizontal IEEE for card guides

- Superior EMC-level
- Only one special extrusion needed
- Card guides can be applied
- Easy and quick assembly
- Cost effective solution
- Usable width: 84 HP
- Other sizes available on request
- **Scope of delivery:**
 - 1 front double extrusion IEEE-Special clear passivated
 - 2 tapped strips M2.5
 - 4 Torx cylinder head screws M4 x 10 (T20)
- For HF spring see below
- For EMC contact strips see below

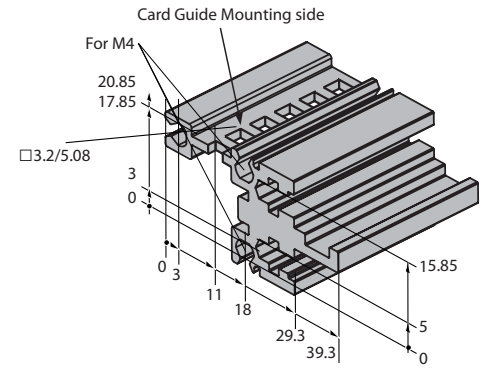

4.5.2.4 EMC Front Sub Division Horizontal IEEE

Description	Part-No.
EMC front sub division horizontal IEEE	63K837-23

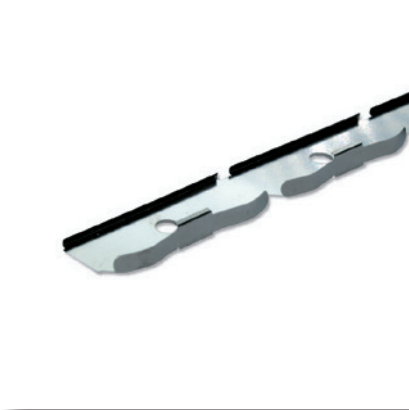

4.5.2.4.1 HF Spring

- Stainless steel
- Snapped-in on the extrusion
- **Scope of delivery:**
 - 2 HF spring 84 HP

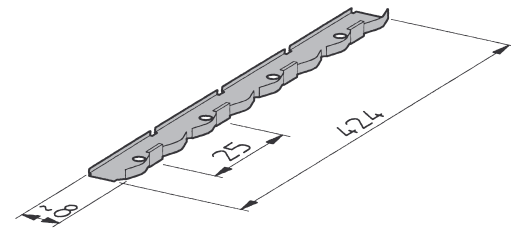

Description	Part-No.
1 set of 2 HF spring 84 HP	7739-14-4



4.5.2.4.2 EMC Contact Strips

- BeCu galvanized
- For front panels, fixing on extrusion
- Self-adhesive
- **Scope of delivery:**
 - 2 EMC contact strips

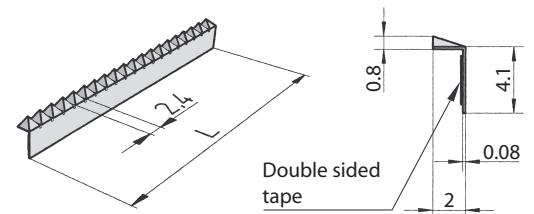

For HP	Length		Part-No.
	mm	inch	
84	424.2	16.70	63-836-70

4.5.2.5 Front Sub Division Vertical for 6 U System or 6 U Assembly

- **Scope of delivery:**
 - 1 divider extrusion front
 - 1 divider extrusion rear
 - 2 front extrusion
 - 2 internal extrusion
 - Assembly material
(16 cylinderhead screws M4 x 10, Torx T20
(4 cylinderhead screws M3 x 12, Torx T10)
- Tapped strips for front extrusion see below

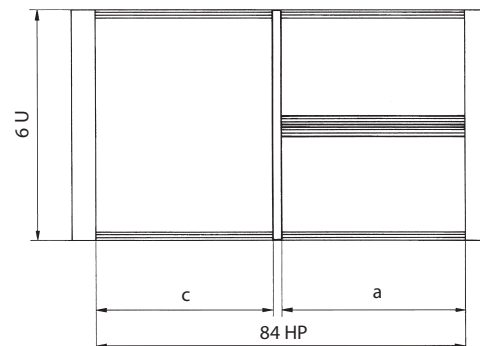

4.5.2.5 Front Sub Division Vertical for 6 U System or 6 U Assembly

Nominal width 6 U (c)	Nominal width 2 x 3 U (a)	Part-No. IEC60297	Part-No. IEEE1101.10
50 HP	32 HP	-	12K959-3
40 HP	42 HP	12K949-2	-



Tapped Strips for Front Extrusion

Scope of delivery	Description	Part-No.
1 pc. tapped strip	M2,5 32 HP = 162.56 mm	61-463
1 pc. tapped strip	M2,5 42 HP = 213.36 mm	61-464

4.5.3 Horizontal Card Mounting Kits

4.5.3.1 Horizontal Card Mounting Kit for Double Eurocards (6 U) (for VME)

- Card depth independent
- Installation width: 52 HP
- **Scope of delivery:**
 - 1 complete set incl. assembly material
- Assembly material for cover plates see below

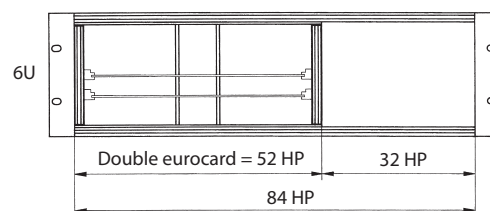

4.4.7 Horizontal Card Mounting Kit for Double Eurocards (6 U) (for VME)

Height/nominal width	Part-No.	Part-No. for cover plate top	Part-No. for cover plate bottom
3 U - 20 HP	14K971-60	21N602-90	21N602-90
4 U - 28 HP	14K981-60	21N602-90	21N603-90
6 U - 48 HP	14K991-60	21N606-90	21N607-90

Front Panel Screws

- Set of 10 screws, with screw retainer

Description	Part-No.
Torx screws M2.5 x 11.3, size T8 with plastic screw retainer	63K159
Rounded head screws recessed M2.5 x 11.3 with plastic screw retainer	63-159



4.5.3.2 EMC Horizontal Card Mounting Kit for Double Eurocards (6 U)

- For 160 mm card depth
- For backplane mounting
- **Scope of delivery:**
 - Card mounting kit incl. fan tray and connector
 - Assembly material included
- ! Fan module has to be on the right side of the horizontal card mounting kit
- Fan not included in the scope of delivery

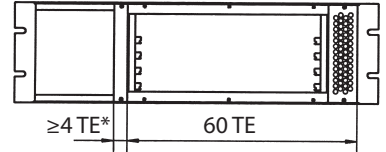

*This space is necessary for the air flow. Assemble blind panel or monitoring module



4.5.3.2 EMC Horizontal Card Mounting Kit for Double Eurocards (6 U)

U	Nominal height	Part-No. CPCI	Part-No. VME64x
4	28 HP	14K987-60	14K988-60

4.5.3.3 EMC Horizontal Card Mounting for 80 / 160 mm Rear I/O Double Eurocards (6 U)

- For 160 mm card depth (VME + VME64x)
- For 80 mm card depth (CPCI)
- For backplane mounting
- **Scope of delivery:**
 - 1 complete set incl. assembly material and cover on side

Top view

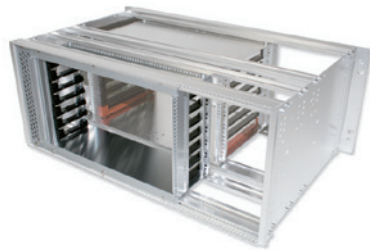
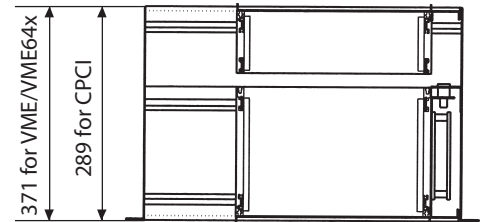

4.5.3.3 EMC Horizontal Card Mounting for 80 / 160 mm Rear I/O Double Eurocards (6 U)

U	Nominal height	Part-No. CPCI	Part-No. VME64x
4	28 HP	14K988-10	14K990-10



4.6 Step E: EMC Shielding

4.6.1 EMC-Set for Bottom/Top Panel, Depth (Advanced EMC-level)

- Use in conjunction with 4.6.2
- **Scope of delivery:**
 - 4 EMC-gasket for depth

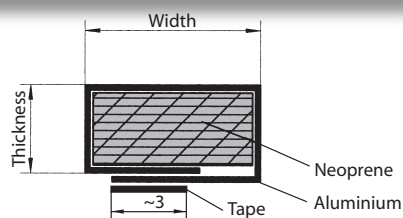

4.6.1 EMC-Set for Bottom/Top Panel, Depth (Advanced EMC-level)

Depth	Part-No.
289 / 291 mm	63K836-15
371 mm	63K836-16
400 mm	63K836-04
500 mm	63K836-05

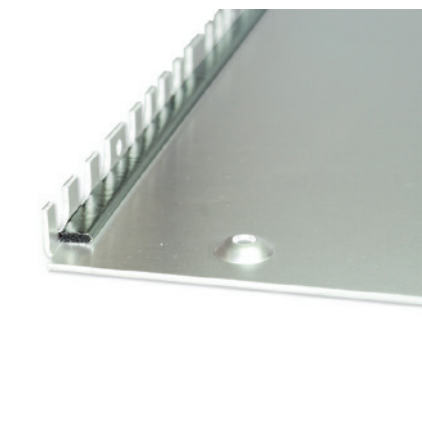

4.6.2 EMC-Set for Bottom / Top Panel, Width (Advanced EMC-level)

- Use in conjunction with 4.6.1
- **Scope of delivery:**
 - 4 EMC-gasket for width

4.6.2 EMC-Set for Bottom / Top Panel, Width (Advanced EMC-level)

Description	Part-No.
4 gaskets, 4 mm x 7 mm x 84 HP, when using height reduction kits 4.4.1 - 4.4.4 at front and rear	63K836-01
4 gaskets, 6 mm x 7 mm x 84 HP, use without height reduction kits (only extrusions)	63K836-02
2 gaskets, 6 mm x 7 mm x 84 HP and 2 gaskets 4 mm x 7 mm x 84 HP, when using only one height reduction kit 4.4.1 - 4.4.4 at front or rear	63K836-03

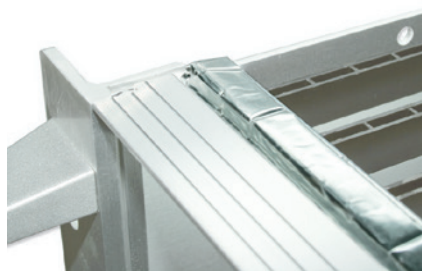

4.6.3 Extrusion for Recessed EMC Mounting (Basic EMC-level)

- Interior fitting: extrusion bolts with side panel
- **Scope of delivery:**
 - 2 EMC-extrusions
 - 8 cylinderhead screws M2.5 x 4, Torx T8
- Application: recessed installation of front panel
- ! Can be used in conjunction with EMC sets 4.6.1 + 4.6.2 and gasket (4.6.4) to achieve advanced EMC level

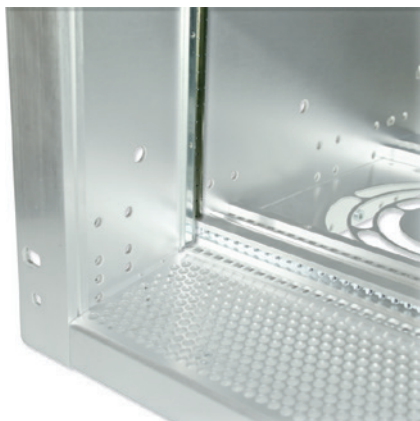
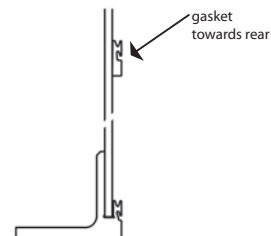

4.6.3 Extrusion for Recessed EMC Mounting (Basic EMC-level)

System height	Extrusion height	in mm	Part-No.
4 U	~3 U	140 mm	63K608
7 U	~6 U	280 mm	63K609

4.6.4 EMC-Gasket for Height Extrusion, Front Panel (Advanced EMC-level)

- Front / rear recessed mounting
- Front panels; 1. slot
- Application: height extrusion front/rear, front panel
- The gasket is installed onto the extrusion
- Use the EMC-gasket in card height whenever used in addition with cards
- When a height reduction is used, choose height between reductions
- ! Can be used in conjunction with EMC sets (4.6.1 - 4.6.3) to achieve advanced EMC level

4.6.4 EMC-Gasket for Height Extrusion, Font Panel (Advanced EMC-level)

U	in mm	Part.-No.
3	101.60 mm	81-062-03
4	146.05 mm	81-062-04
6	234.95 mm	81-062-06
7	279.40 mm	81-062-07
9	368.30 mm	81-062-09



4.6.5 EMC Contact Strips (Advanced EMC-level)

- For front panels, fixing on extrusion
- Self adhesive
- **Scope of delivery:**
 - 2 contact strips

4.6.5 EMC Contact Strips (Advanced EMC-level)

HP	Length	Part-No.
42	212.1 mm = 8.48"	63-836-67
84	424.2 mm = 16.97"	63-836-70



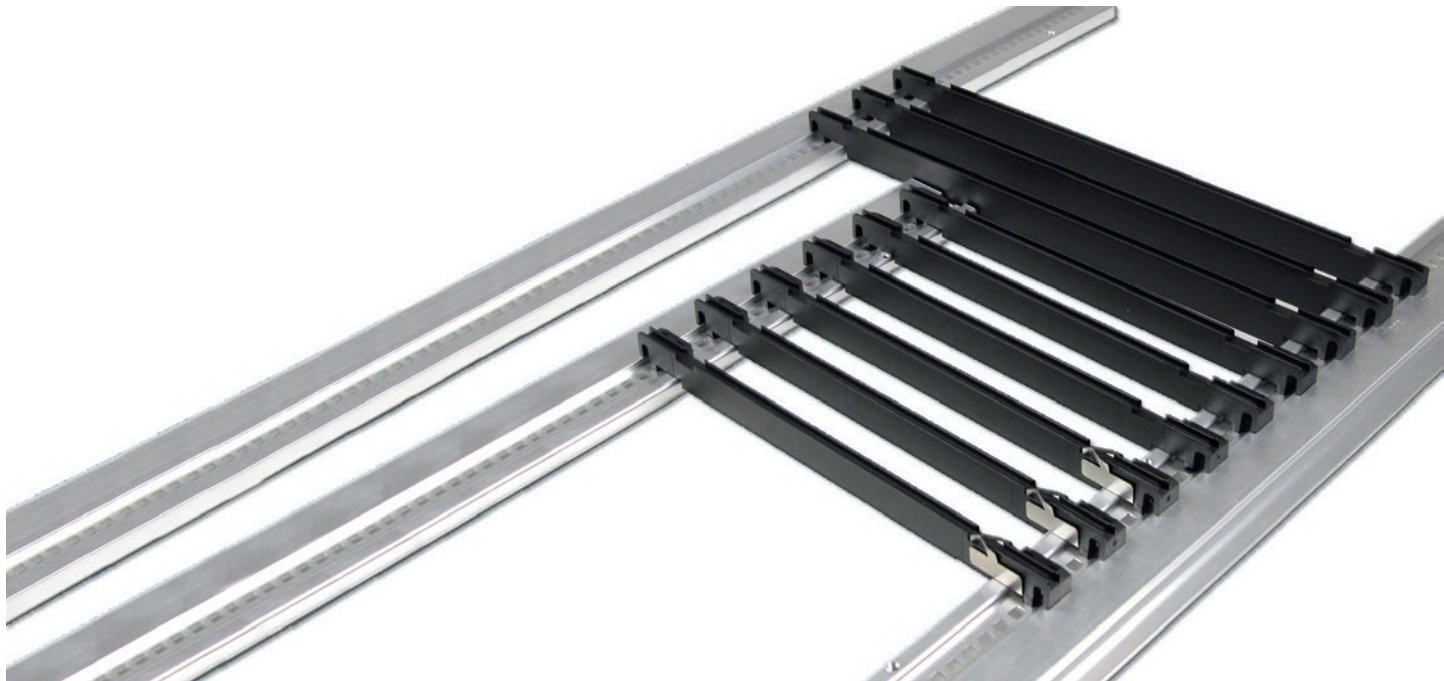

4.7 Step F: General Accessories

4.7.1 Mounting Chassis

4.7.1.1 Mounting Chassis, Rugged Design (Aluminium, 2 mm)

- **Scope of delivery:**

- Assembly material included
(4 earthing nuts M4, 4 cylinderhead screws M4 x 6, Torx T20)
- Mounting chassis 85 HP (431.8 mm)

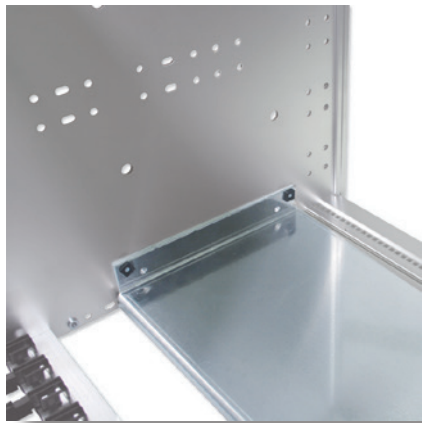
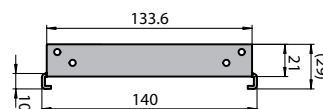
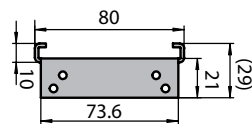

4.7.1.1 Mounting Chassis, Rugged Design (Aluminium, 2 mm)

Description	Part-No.
Depth: 140 mm	14K836-50

4.7.1.2 Mounting Chassis Full Depth of Systemkit 12K

- For mounting non-standard modules and components
- Mounting chassis is fixed directly on the side panel
- Aluminium 2.0 mm, raw
- **Scope of delivery:**
 - 1 mounting chassis
- Assembly material see below
- Mounting chassis depth 207 mm can be mounted with 4 screws (317mm with 8 screws, 419mm with 10 screws)

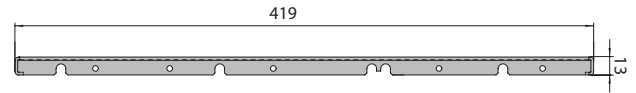
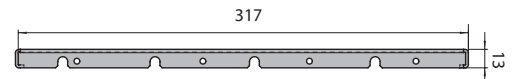
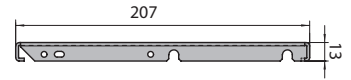

4.7.1.2 Mounting Chassis, Rugged Design (Aluminium, 2 mm)



Sub Rack Depth		Chassis Depth		Part-No.
mm	inch	mm	inch	
289 / 291 mm	11.37 / 11.45	207 mm	8.15	14K850
400 mm	15.74	317 mm	12.48	14K851
500 mm	19.68	419 mm	16.49	14K852

Assembly Material

- For one mounting chassis
- **Scope of delivery:**
 - 4 Torx cylinder head screw M4 x 6, size T20
 - 4 earthing nut M4

Description	Part-No.
Assembly material for mounting chassis with Torx-Screws	63K861

4.7.2 Card Guides

4.7.2.1 Card Guides IEC

- For positive location of circuit boards and plug-in units conforming to the dimensions of card depths 80 mm, 160 mm, 220 mm and 280 mm
- The card guides are non-flammable, made from a highquality plastic material reinforced with fibreglass UL94 V-0
- Including ESD provisions

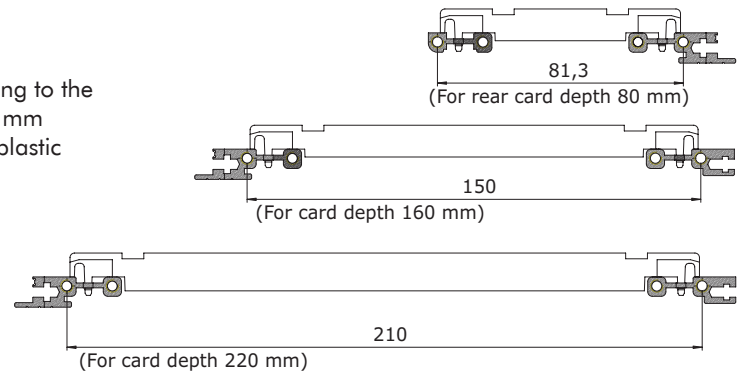

4.7.2.1.1 Card Guides 1-Slot, IEC

- **Scope of delivery:**
 - Card guide black plastic UL94 V-0
- ESD Clip see below (not usable for card depth 80 mm)



Card Thickness		Card Depth		Part-No.
mm	inch	mm	inch	
1.6	0.06	80	3.15	61-019
		160	6.30	61-044
		220	8.66	61-039
		280	11.02	61-017
2.0	0.08	160	6.30	61-087
		220	8.66	61-039
		280	11.02	61-169

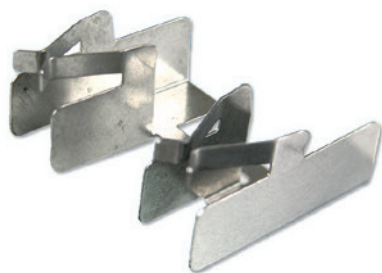

4.7.2.1.2 ESD Clips

- Connecting printed board with case
- Stainless steel

Description	Part-No.
ESD clip front bottom/rear top	61-419-01
ESD clip front top/rear bottom	61-419-02



4.7.2.1.3 Card Guides 7-Slot in 4 HP Steps, IEC

- For reduced assembly time of multiple slot applications
- For use with single, double and triple eurocards with a depth of 160 mm
- For card thickness: 1.6 mm / 0.06"
- Black plastic, UL94 V-0
- ESD Clip not usable

Card Thickness		Card Depth		Part-No.
mm	inch	mm	inch	
1.6	0.06	160	6.30	61-076



4.7.2.1.4 Aluminium Card Guides 1-Slot, 3 Parts, IEC

- Extrusion: Aluminium
- End feet: plastic, UL94 HB
- For card thickness: 1.6 mm / 0.06"
- Card guide extrusion, aluminium, clear anodised
- ESD clip not usable

Extrusion

Card Depth		Length		Part-No. Aluminium
mm	inch	mm	inch	
160	6.30	112.5	4.43	66-122-20
220	8.66	172.5	6.79	66-122-21
280	11.02	232.5	9.15	66-122-22
340	13.38	292.5	11.51	66-122-23
400	15.74	352.5	13.87	66-122-24
-	-	1350	53.15	66-122-14

End Feet

Description	Part-No. 1 Pair
End feet plastic, UL94 HB	61-069

4.7.2.1.5 Card Guide Board-Retention Bar

Description	Part-No. 20 pcs.
Board-retention bar, zinc-plated steel	61-291

Assembly Material

Description	Part-No.
Cross recessed round head screw M3 x 4	5331-04
Torx cylinder head screw M3 x 4, size T10	5470-01

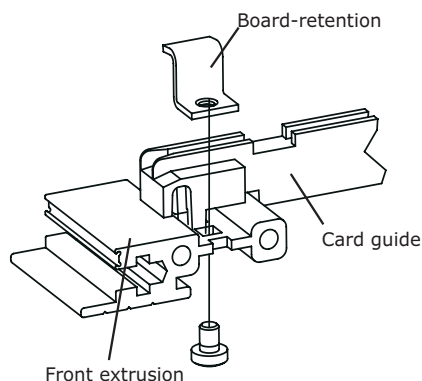

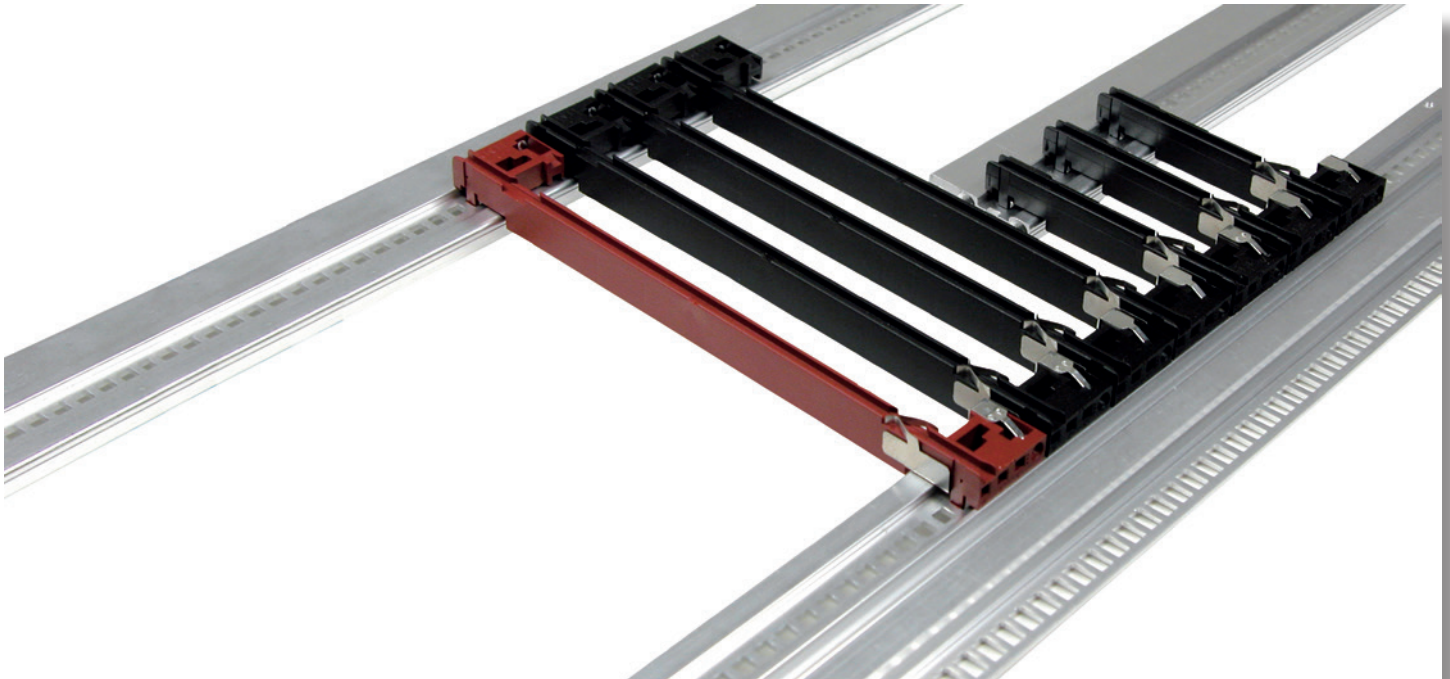

4.7.2.2 Card Guides acc. to IEEE

- For positive location of PCBs and plug-in units conforming to the dimensions of card depths 80 mm, 160 mm, 220 mm, 280 mm and 340 mm
- The card guides are non-flammable, made from a highquality plastic material reinforced with fibreglass UL94 V-0
- With ESD provisions
- With keying and alignment pin possibilities

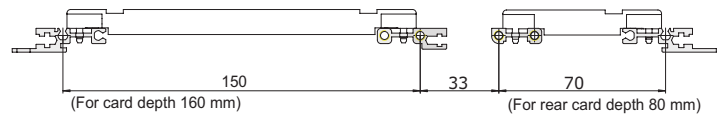

4.7.2.2.1 Card Guides 1-Slot, IEEE

- Card thickness 1.6 mm / 0.06" and 2.0 mm / 0.08"
- Plastic UL94 V-0



Card Depth		Colour	Part-No. 1 Pair
mm	inch		
80	3.15	black	61-949-01

Card Depth		Colour	Part-No. 1 pc.
mm	inch		
160	6.30	black	61-950-01
160	6.30	red	61-950-03

4.7.2.2.2 Card Guides 1-Slot, incl. mounted ESD-Components, IEEE

- Bottom: 1 ESD clip and 1 ESD spring
- Top: 1 ESD spring
- Black plastic UL94 V-0



Card Depth		Description	Part-No. 1 Pair
mm	inch		
80	3.15	1 pair top/bottom	61-949-02

Card Depth		Description	Part-No. 1 pc.
mm	inch		
160	6.30	1 piece bottom	61-950-02
160	6.30	1 piece top	61-950-04

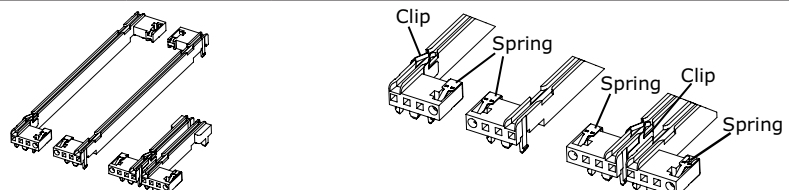



4.7.2.2.3 Aluminium Card Guides 1-Slot, 3 Parts, 1.6 mm, IEEE

- Extrusion: Aluminium
- End feet: Plastic UL94 V-0
- For card thickness 1.6 mm / 0.06" and 2.0 mm / 0.08"

Extrusion

Card Depth		Part-No.
mm	inch	
160	6.30	66-452-20
220	8.66	66-452-25
280	11.02	66-452-30
340	13.38	66-452-35

End Feet

Colour	Part-No. 1 Pair
Black	61-955-01
Red	61-955-03

End Feet Offset

Colour	Part-No. 1 Pair
Pearlwhite	61-961-01

4.7.2.2.4 Aluminium Card Guides 1-Slot, 3 Parts, 2.4 mm, IEEE

- Extrusion: Aluminium
- End feet: Plastic UL94 V-0
- For card thickness 2.4 mm / 0.094"

Extrusion

Card Depth		Part-No. 1 pc.
mm	inch	
160	6.30	66-453-20
220	8.66	66-453-25
280	11.02	66-453-30
340	13.38	66-453-35

End Feet

Colour	Part-No. 1 Pair
Black	61-956-01





4.7.2.2.5 ESD Clips

- Connecting printed board with case

Description	Part-No.
ESD clip front bottom/rear top	61-419-01
ESD clip front top/rear bottom	61-419-02



4.7.2.2.6 ESD Spring

- Connecting ESD pin with case
- BeCu finned
- Note: Notch inward-looking

Description	Part-No.
ESD spring	61-420



4.7.2.2.7 Coding Pins

- Acc. to IEC 60297-3-103
- Plastic, UL94 V-0
- Can be rotated in 4 positions

Description	Part-No.
Grey	81-054-02
Dark red	81-054-06
Black	81-054-04

4.7.3 Plug-in Units

4.7.3.1 EMC Front Panels for IEC Plug-In Units with Cutouts for Ejector Handles acc. to IEC

- EMC Front Panels Aluminium with EMC Gasket
- Excellent EMC shielding
- Immune to snagging
- EMC-gasket slides onto the extrusion
- **Scope of delivery:**
 - EMC front panel, incl. pressed-in bushes M2.5 (size ≥ 10 HP)
- EMC-gasket see below
- Handle has to be ordered separately, see 4.7.3.2
- Front panel screw (size ≥ 10 HP), see below

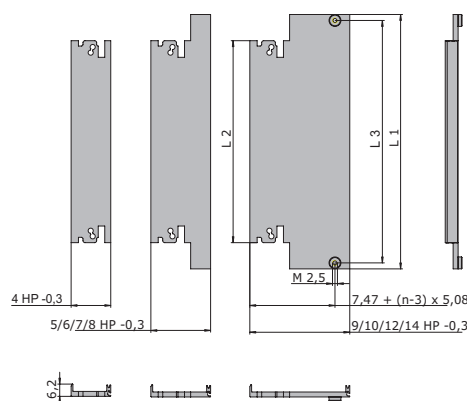

4.7.3.1.1 Front Anodised, Rear Conductive (2 cutouts)

- With 2 cutouts (bottom + top)

Width	Part-No. 3 U	Part-No. 6 U	Part-No. 9 U
4 HP	66-514-23	66-514-26	66-514-29
5 HP	66-515-23	66-515-26	-
6 HP	66-516-23	66-516-26	66-516-29
7 HP	66-517-23	66-517-26	-
8 HP	66-518-23	66-518-26	66-518-29
9 HP	66-519-23	66-519-26	-
10 HP	66-520-23	66-520-26	66-520-29
12 HP	66-522-23	66-522-26	-
14 HP	66-534-23	66-534-26	-

4.7.3.1.2 Front Anodised, Rear Conductive (1 cutout)

- With 1 cutout (bottom)
- Incl. pressed-in centring pin and bush M2.5 (top)
- Incl. cutout for mounting of card holder 61-156 (top) with screw 5322-08 (see 2.2.2.7)

Width	Part-No. 3 U
4 HP	66-514-43
5 HP	66-515-43
6 HP	66-516-43
8 HP	66-518-43
10 HP	66-520-43
12 HP	66-522-43
14 HP	66-534-43

Dimensions

Height	L1 mm	L1 inch	L2 mm	L2 inch	L3 mm	L3 inch
3 U	128.55	5.06	102.05	4.01	122.50	4.82
6 U	261.90	10.31	235.40	9.27	255.85	10.07
9 U	395.25	15.56	368.75	14.51	389.20	15.32

4.7.3.1.4 EMC-Gasket (Stainless Steel)

Unit	Part-No. 3 U	Part-No. 6 U	Part-No. 9 U
1 pc.	81-062-03	81-062-06	81-062-09

Front Panel Screw

- For EMC front panels size ≥ 10 HP = 2 additional screws are needed

Description	Part-No.
Cross recessed round head screws M2.5 x 12.7	61-287
Torx screws M2.5 x 11.3, size T8	5443-08

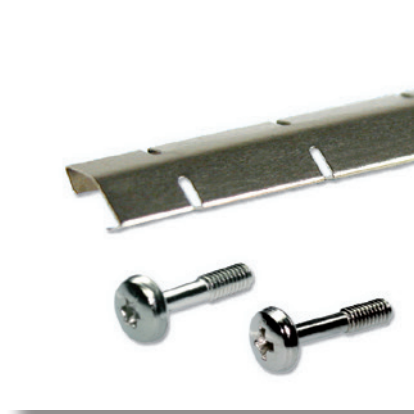

4.7.3.2 Ergonomic Ejector Handles acc. to IEC

- Simple assembly of plug-in units
- Allows trouble-free extraction of electronic units with multi-pole connectors
- Main features in one part: card holder, ejector handle and centring pin
- Reset spring for safe insertion
- One version for top and bottom only
- Handle is injection moulded, glass-reinforced plastic, UL94 V-0
- Card holder is zinc die-cast, nickel plated
- Reset spring is stainless steel
- Scope of delivery:**
 - Ejector handle
 - Assembly material (cross recessed screws M2.5 for fixing of card holder/printed board/front panel)
- Front panel with special cutouts have to be ordered separately

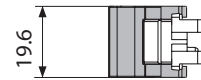
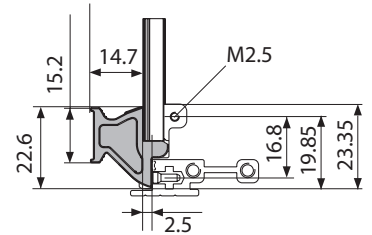

4.7.3.2 Ergonomic Ejector Handles acc. to IEC

Description	Part-No.
Ejector handle black	81-233
Ejector handle grey	81-234

Extraction process:

Rest position

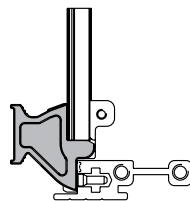

Extraction

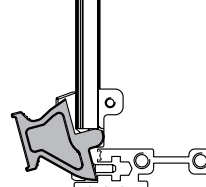

End position

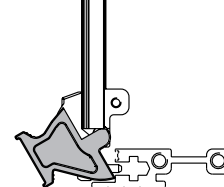

Label

Description	Part-No.
1 sheet A4 of 220 labels	81-031



4.7.3.3 Card Holder acc. to IEC Standard

- By using the zinc die-cast card holder, flat front panels and EMC front panels acc. to IEC can be connected to a PC card to form a plug-in unit
- The card can be mounted both in the standard position and offset 1 HP (5.08 mm)
- **Scope of delivery:**
 - Card holder
- Assembly material see below

4.7.3.3.1 Card Holder without Swivel Stop

Description	Application	D	Part-No.
Card holder without swivel stop	Without injector / ejector handle	M2.5	61-156

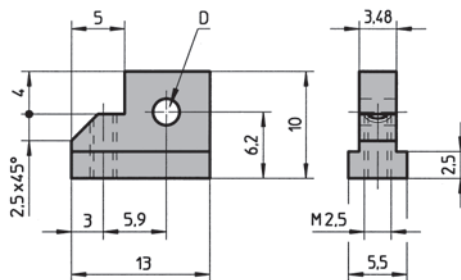

Assembly Material

Description	Application	Part-No.
Cross recessed countersunk screw M2.5 x 8	For card holder	5322-08
Torx countersunk screw M2.5 x 8, size T8	For card holder	5470-21
Slotted pan head screw M2.5 x 6	For printed board	5571-06
Torx cylinder head screw M2.5 x 6, size T8	For printed board	5470-04

4.7.3.4 Card Holder/End Piece without ESD Pin

- **Scope of delivery:**
 - End piece card holder (zinc die-cast, nickel plated)
 - Assembly material (screws M2.5 for fixing of front panel/card holder/printed board)

4.7.3.4 Card Holder/End Piece without ESD Pin

Description	Part-No.
Top	81-018-01
Bottom	81-019-01

4.7.3.5 EMC Front Panels Aluminium with EMC Gasket acc. IEEF

- Excellent EMC shielding
- Immune to snagging
- EMC-gasket slid onto the extrusion
- **Scope of delivery:**
 - EMC front panel, incl. press-in bushes M2.5 (size \geq 10 HP)
- EMC-gasket see below
- Handle has to be ordered separately, see 4.7.3.7
- Front panel screw (size \geq 9 HP), see 4.7.3.5.5



4.7.3.5.1 Front Anodised, Rear Conductive (2 cutouts)

- With 2 cutouts (bottom + top)

Width	Part-No. 3 U	Part-No. 6 U
4 HP	66-514-23	66-514-26
5 HP	66-515-23	66-515-26
6 HP	66-516-23	66-516-26
7 HP	66-517-23	66-517-26
8 HP	66-518-23	66-518-26
9 HP	66-519-23	66-519-26
10 HP	66-520-23	66-520-26
12 HP	66-522-23	66-522-26
14 HP	66-534-23	66-534-26

4.7.3.5.2 Front Anodised, Rear Conductive (1 cutout)

- With 1 cutout (bottom)
- Incl. pressed-in centring pin and bush M2.5 (top)
- Incl. cutout for mounting of card holder 61-156 (top) with screw 5322-08 (see 2.2.2.4)

Width	Part-No. 3 U
4 HP	66-514-43
5 HP	66-515-43
6 HP	66-516-43
8 HP	66-518-43
10 HP	66-520-43
12 HP	66-522-43
14 HP	66-534-43

4.7.3.5.4 EMC-Gasket (Stainless Steel)

Unit	Part-No. 3 U	Part-No. 6 U
1 pc.	81-062-03	81-062-06

4.7.3.5.5 Front Panel Screw

- For EMC front panels size ≥ 9 HP = 2 additional screws are needed

Description	Part-No.
Cross recessed round head screws M2.5 x 12.7	61-287
Torx screws M2.5 x 11.3, size T8	5443-08

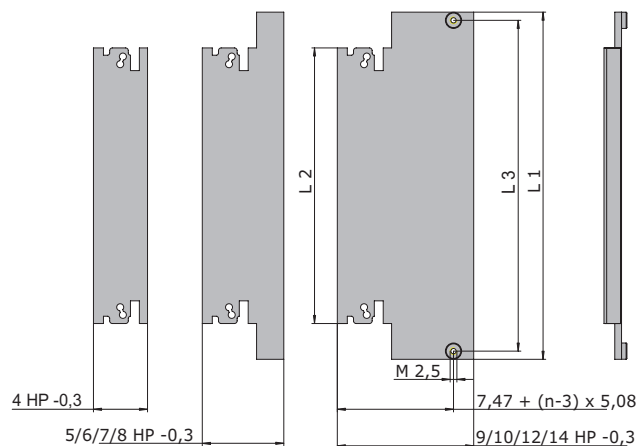

Dimensions

Height	L1 mm	L1 inch	L2 mm	L2 inch	L3 mm	L3 inch
3 U	128.55	5.06	102.05	4.01	122.50	4.82
6 U	261.90	10.31	235.40	9.27	255.85	10.07

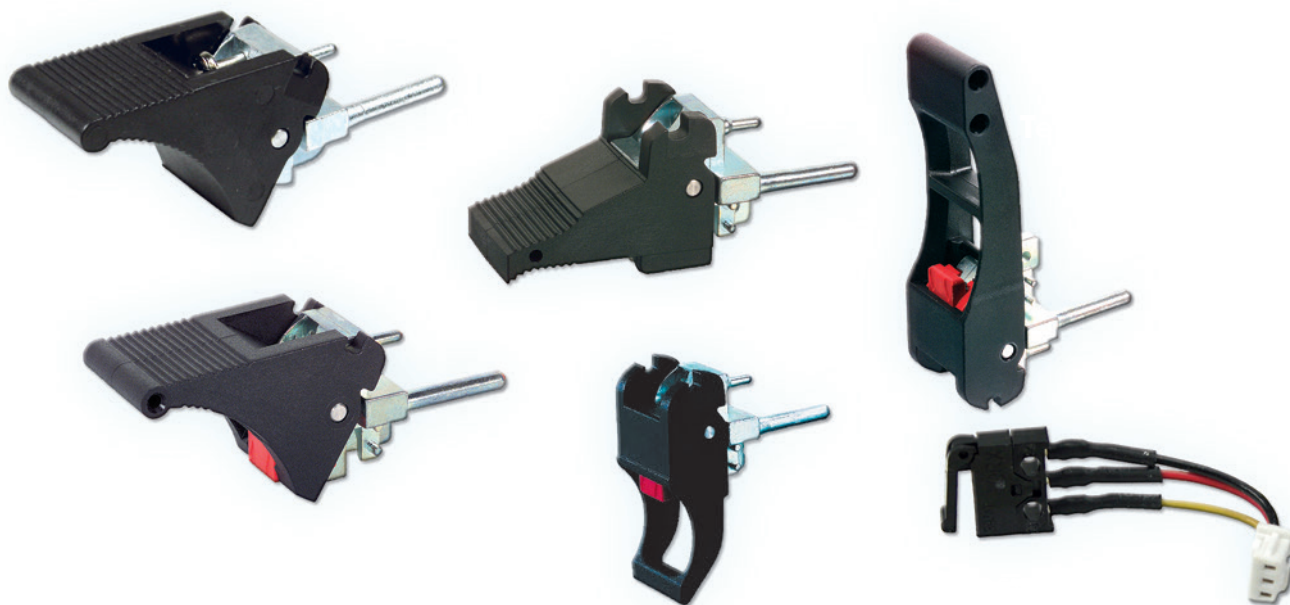

4.7.3.7 Injector/Ejector Handles acc. to IEEE

Type			Mounting	ESD Pin	Colour	Part-No.
Ergonomic			Bottom	With ESD-pin	Black	81-076
Ergonomic			Top	With ESD-pin	Black	81-075
Ergonomic			Bottom	Without ESD-pin	Black	81-076-01
Ergonomic			Top	Without ESD-pin	Black	81-075-01
Ergonomic	Hot Swap		Bottom	With ESD-pin	Black	81-096
Ergonomic	Hot Swap		Top	With ESD-pin	Black	81-095
Ergonomic	Hot Swap		Bottom	Without ESD-pin	Black	81-096-01
Ergonomic	Hot Swap		Top	Without ESD-pin	Black	81-095-01
Ergonomic	Hot Swap	Offset	Bottom	With ESD-pin	Black	81-185
Ergonomic	Hot Swap	Offset	Top	With ESD-pin	Black	81-184
Classic			Bottom	With ESD-pin	Black	81-261
Classic			Top	With ESD-pin	Black	81-260
Classic		Offset	Bottom	With ESD-pin	Black	81-161
Classic		Offset	Top	With ESD-pin	Black	81-160
Classic	Hot Swap		Bottom	With ESD-pin	Black	81-256
Classic	Hot Swap		Top	With ESD-pin	Black	81-255
Classic	Hot Swap	Offset	Bottom	With ESD-pin	Black	81-156
Classic	Hot Swap	Offset	Top	With ESD-pin	Black	81-155
Telecom	Hot Swap		Bottom	With ESD-pin	Black	81-206
Telecom	Hot Swap		Top	With ESD-pin	Black	81-205
Telecom	Hot Swap		Bottom	Without ESD-pin	Black	81-206-01
Telecom	Hot Swap		Top	Without ESD-pin	Black	81-205-01
Telecom	Hot Swap	Offset	Bottom	With ESD-pin	Black	81-189
Telecom	Hot Swap	Offset	Top	With ESD-pin	Black	81-188
Telecom long	Hot Swap		Bottom	With ESD-pin	Black	81-215
Telecom long	Hot Swap		Top	With ESD-pin	Black	81-214
Telecom long	Hot Swap	Offset	Bottom	With ESD-pin	Black	81-116
Telecom long	Hot Swap	Offset	Top	With ESD-pin	Black	81-117
Microswitch						81-088-1 (10 pcs.)

For more information refer to chapter C|3 "Handles".

4.7.8.8 Card Holder and Coding Pins acc. to IEEE

• Scope of delivery:

- End piece card holder (zinc die-cast, nickel plated)
- Assembly material
(screws M2.5 for fixing of front panel/card holder/printed board)

4.7.3.8.1 Card Holder/End Piece with ESD Pin

Description	Part-No.
Top	81-018
Bottom	81-019

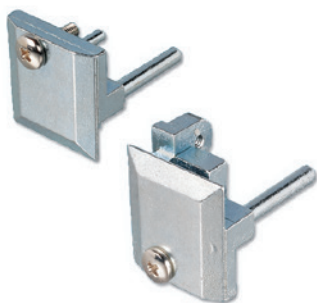

4.7.3.8.2 Card Holder/End Piece without ESD Pin

Description	Part-No.
Top	81-018-01
Bottom	81-019-01



4.7.3.8.3 Middle Part

- Usable for all front panels
- For positioning and fixing of 6 U and 9 U cards, card thickness 1.6 mm
- Material: Plastic UL94 V-0

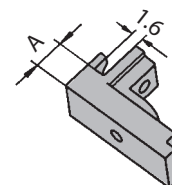

Description	A		Part-No.
	mm	inch	
Aluminium 2.5 mm	2.5	0.10	61-960

Assembly Material

Description	Part-No.
PT-countersunk, 2.5 x 6	5534-06

4.7.3.8.4 Coding Pins

- Acc. to IEC 60297-3-103
- Plastic, UL94 V-0
- Can be rotated in 4 positions

Description	Part-No.
Grey	81-054-02
Dark red	81-054-06
Black	81-054-04



4.7.4 Front Panels

4.7.4.1 EMC Flat Front Panels

- Aluminium 2.5 mm (conductive)
- Closes the front or rear of the sub rack with very high shielding effectiveness
- Contact between the flat front panel and the case is made via EMC gaskets

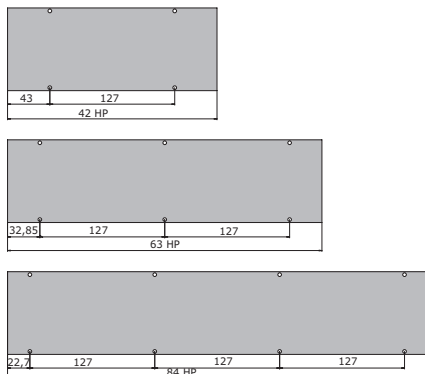

4.7.4.1.1 Advanced EMC Level

- **Scope of delivery:**
 - EMC flat front panel
 - Contact angle, incl. screws (4 + 6 U version only)
 - EMC gasket for contact angle (4 + 6 U version only)
- Front panel screws see below
 - Front panel width 42 HP = 4 screws
 - Front panel width 63 HP = 6 screws
 - Front panel width 84 HP = 8 screws

Width	Part-No. 1 U	Part-No. 2 U	Part-No. 3 U	Part-No. 4 U	Part-No. 6 U
42 HP	-	-	21C342	-	-
63 HP	-	21C263	21C363	21C463	-
84 HP	21C184	21C284	21C384	21C484	21C684

1 U - 3 U

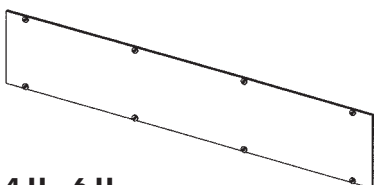

4 U - 6 U

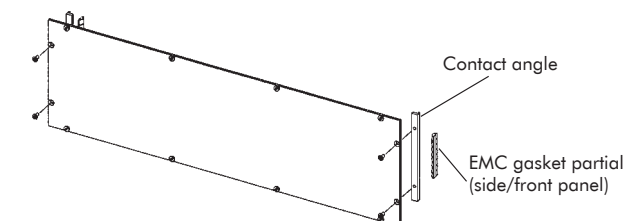

4.7.4.1.2 Front Panel Screws

Description	Part-No. 10 pcs.
Torx screws M2.5 x 11.3, size T8, with press-fit bush	63K480
Screw recessed M2.5 x 11.3, with press-fit bush	63-444
Screw cross recessed M2.5 x 12.7, with press-fit bush	63-480

4.7.4.2 Superior EMC Level

- **Scope of delivery:**
 - EMC flat front panel
 - Contact angle, incl. screws
 - EMC gasket for contact angle
 - EMC gasket for front extrusion/front panel
- Front panel screws, see below
 - Front panel width 42 HP = 4 screws
 - Front panel width 63 HP = 6 screws
 - Front panel width 84 HP = 8 screws

2 U - 6 U

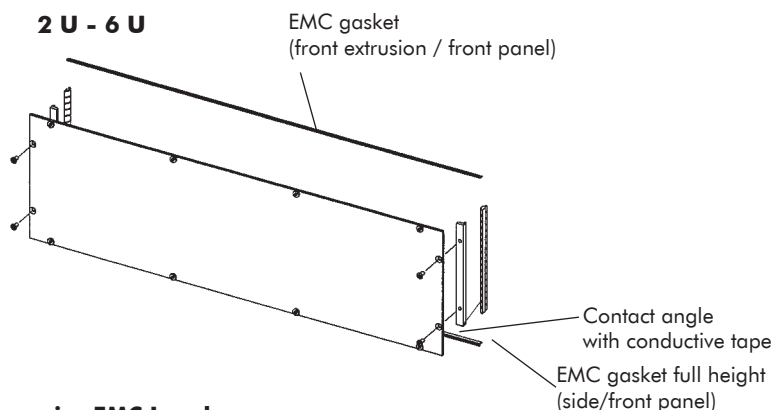

4.7.4.2 Superior EMC Level

Width	Part-No. 2 U	Part-No. 3 U	Part-No. 4 U	Part-No. 6 U
84 HP	21D284	21D384	21D484	21D684

4.7.4.2.1 Front Panel Screws

Description	Part-No. 10 pcs.
Torx screws M2.5 x 11.3, size T8, with press-fit bush	63K480
Screw recessed M2.5 x 11.3, with press-fit bush	63-444
Screw cross recessed M2.5 x 12.7, with press-fit bush	63-480

4.7.4.3 Perforated EMC Front Panel 84 HP

- Front anodised, rear conductive
- Advanced EMC level
- Width: 84 HP
- **Scope of delivery:**
 - Perforated flat front panel
- Front panel screws see below
- On-off switch see below

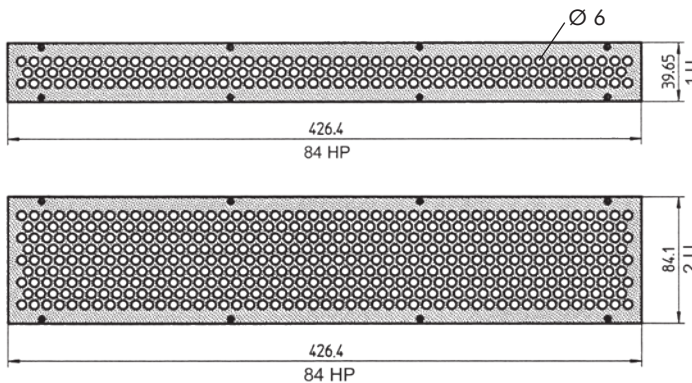

4.7.4.3 Perforated EMC Front Panel 84 HP

	Height		Air Passage	Switch Opening Part-No. without
1 U	39.65 mm	1.56"	4'100 mm ²	21C184-01
2 U	84.1 mm	3.31"	12'300/11'700 mm ²	21C284-01

Front Panel Screws

Description	Part-No. 10 pcs.
Torx screws M2.5 x 11.3, size T8, with press-fit bush	63K480
Screws recessed M2.5 x 11.3, with press-fit bush	63-444
Screws cross recessed M2.5 x 12.7, with press-fit bush	63-480

4.7.4.4 EMC Filler Panel without EMC-Gasket

- Front panel standard, solid
- Front clear anodised
- Rear conductive
- Basic level EMC
- **Scope of delivery:**
 - 1 front panel incl. press-fit bushes M2.5 (pressed-in)
- Front panel screws, see below
- Spacer see below

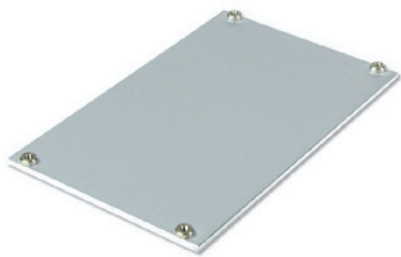

4.7.4.4 EMC Filler Panel without Gasket

Width	Part-No. 3 U	Part-No. 4 U	Part-No. 6 U
4 HP	21B304	-	-
10 HP	21B310	-	-
12 HP	21B312	-	-
16 HP	21B316	21B416	-
21 HP	21B321	21B421	-
42 HP	21B342	21B442	21B642
63 HP	21B363	21B463	-
84 HP	21B384	21B484	21B684

Front Panel Screws

- Front panel width up to 9 HP = 2 screws; ≥ 10 HP = 4 screws

Description	Part-No.
Torx screw, M2.5 x 11.3, size T8	5443-08
Round head screw, cross recessed M2.5 x 12.7	61-287

4.7.4.4.1 Spacer for EMC Front Panel Flat

- EMC-Level: Advanced
- **Scope of delivery:**
 - 1 spacer incl. gasket
 - 2 Torx sheet metal screws 2.9 x 6.5; size T 10

Height	Part-No.
3 U	81K023
4 U	81K024
7 U	81K027

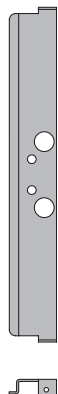

Holes in some cases needed for mounting telescopic rails

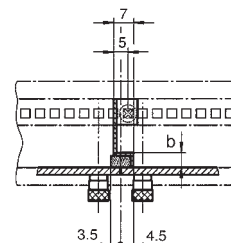
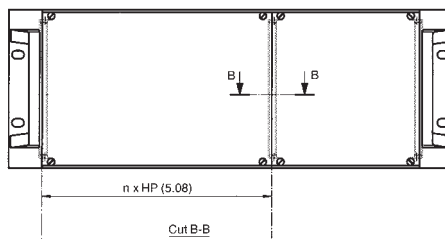

4.7.4.5 Flat Front Panels

- For sub racks and enclosures, solid
- Aluminium 2.5 mm, clear anodised (non-conductive)
- **Scope of delivery:**
 - Flat front panel
- Front panel screws, see below

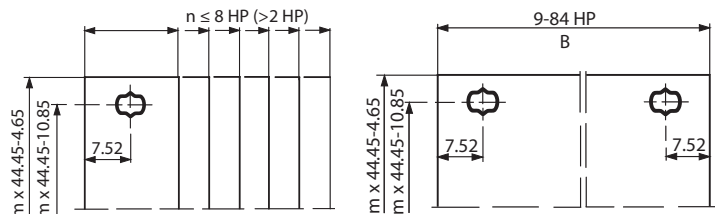

4.7.4.5.1 Flat Front Panels for Sub Racks and Enclosures, Solid

Width	B		Height		Part-No.					
	mm	inch	1 U 39.8 mm	ca. 1 U* 42.15 mm	2 U 84.2 mm	3 U 128.7 mm	4 U 173.1 mm	6 U 262.0 mm	7 U 306.5 mm	9 U 395.4 mm
2 HP	10.0	0.39	-	-	-	21N302	-	21N602	-	-
3 HP	15.2	0.59	-	-	-	21N303	21N403	21N603	-	-
4 HP	20.1	0.79	-	-	-	21N304	21N404	21N604	-	21N904
5 HP	25.2	0.99	-	-	-	21N305	21N405	21N605	-	-
6 HP	30.3	1.19	-	-	-	21N306	21N406	21N606	-	-
7 HP	35.3	1.38	-	-	-	21N307	21N407	21N607	-	-
8 HP	40.4	1.59	-	-	-	21N308	21N408	21N608	-	-
10 HP	50.6	1.99	-	-	-	21N310	21N410	21N610	-	-
11 HP	55.7	2.19	-	-	-	21N311	-	-	-	-
12 HP	60.7	2.38	-	-	-	21N312	21N412	21N612	-	-
14 HP	70.9	2.79	-	-	-	21N314	21N414	21N614	-	-
16 HP	81.1	3.19	-	-	-	21N316	21N416	21N616	-	-
20 HP	101.4	3.59	-	-	-	21N320	21N420	21N620	-	-
21 HP	106.5	4.19	-	-	-	21N321	-	21N621	-	-
28 HP	142.0	5.59	-	-	-	21N328	-	21N628	-	-
32 HP	162.3	6.38	-	-	-	21N332	21N432	-	-	-
42 HP	213.1	8.38	-	-	21N242	21N342	21N442	21N642	-	-
52 HP	263.9	10.38	-	-	-	21N352	21N452	21N652	-	-
63 HP	319.8	12.59	-	-	21N263	21N363	21N463	21N663	-	-
81 HP	411.3	16.19	-	-	21N281	21N381	21N481	-	-	-
84 HP	426.5	16.79	21N184	21N084*	21N284	21N384	21N484	21N684	21N784	21N984

* Coverplates for 1 U fan opening

Front Panel Screws

- Set of 10 screws, with screw retainer

Description	Part-No.
	10 pcs.
Torx screws M2.5 x 11.3, size T8 with plastic screw retainer	63K159
Rounded head screws recessed M2.5 x 11.3 with plastic screw retainer	63-159

4.7.5 Telesopic Rails

4.7.5.1 Telesopic Rails, Set (Load Capacity up to 60 kg/Pair)

- Telesopic rails, suitable for all heights
- **Scope of delivery:**
 - 2 telesopic rails
 - Mounting bracket
 - Assembly material for mounting into cabinet and on module

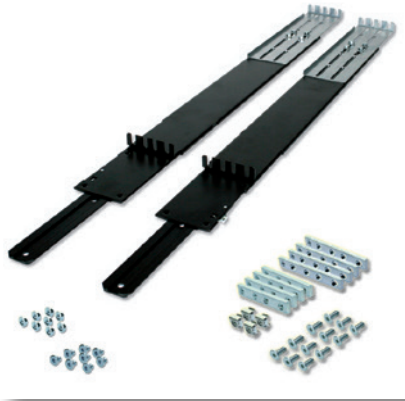

4.7.5.1 Telesopic Rails, Set (Load Capacity up to 60 kg/Pair)

Max. withdraw	Usable depth		Part-No.
	min.	max.	
511.2 mm	463 mm	681.8 mm	65-051
596.4 mm	564.6 mm	783.4 mm	65-052
719.6 mm	666.2 mm	885.0 mm	65-053

Rugged telesopic rails (load capacity up to 90 kg/pair) on request

4.8 Step G: Extrusions

4.8.1 Front Extrusions

4.8.1.1 Front Extrusion, VME

- For sub racks and cases front
- Accept 2 x 6 mm tapped strips
- **Scope of delivery:**
 - 1 front extrusion without assembly material

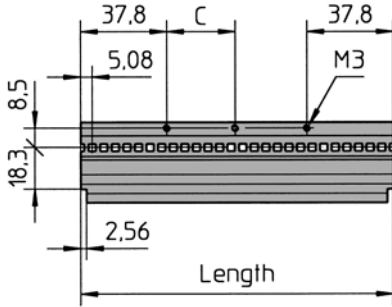

4.8.1.1 EMC Version

Length for HP	mm		Holes n x C	Part-No. clear passivated
	mm	inch		
84	431.8	17.00	4 x 89.05	66-111-153

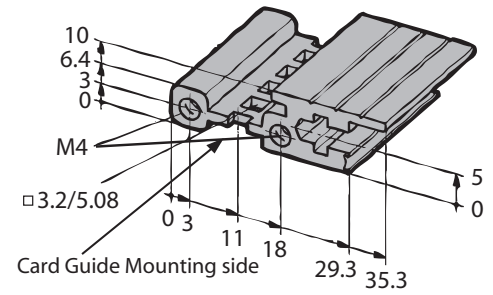

4.8.1.2 Front Extrusion, CPCI / VME64x

- Front separation extrusion according to IEEE standard
- Accept 2 x 6 mm tapped strips
- **Scope of delivery:**
 - 1 front extrusion without assembly material

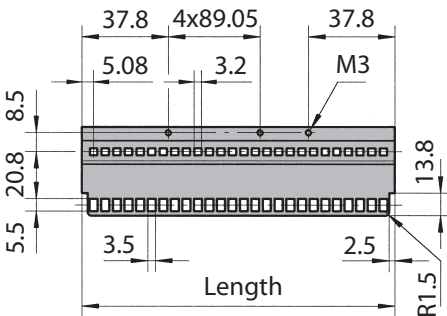

4.8.1.2 Version for Systemkit 12K according to IEEE standard

Length for HP	mm		Holes n x C	Part-No. clear passivated
	mm	inch		
84	431.8	17.00	4 x 89.05	66-677-33

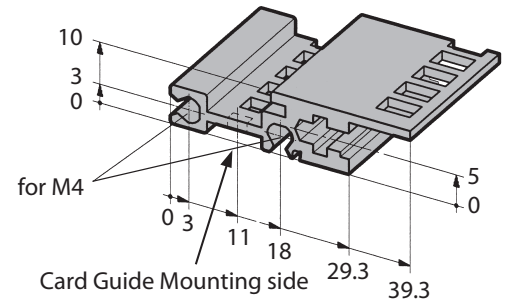

4.8.2 Internal Extrusions

4.8.2.1 Internal Extrusion 66-193 for Insulated Backplane Mounting

- For mounting backplanes in sub racks
- Insulating strip see 4.8.2.7
- Accept 1.8 x 5 mm tapped strips
- **Scope of delivery:**
 - 1 extrusion without assembly material

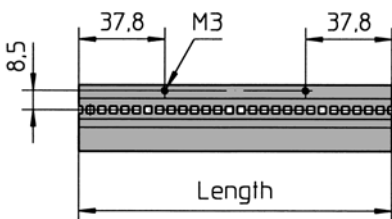

4.8.2.1 Standard Version

Length for HP	mm		Holes n x C	Part-No. clear passivated
	mm	inch		
84	431.8	17.00	4 x 89.05	66-193-23

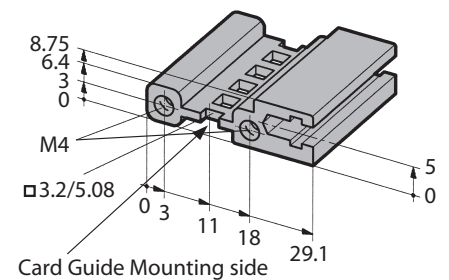

4.8.2.2 Internal Extrusion 66-194 for Conductive Backplane Mounting

- For mounting backplanes without an insulating strip
- Accept 1.8 x 5 mm tapped strips
- **Scope of delivery:**
 - 1 extrusion without assembly material

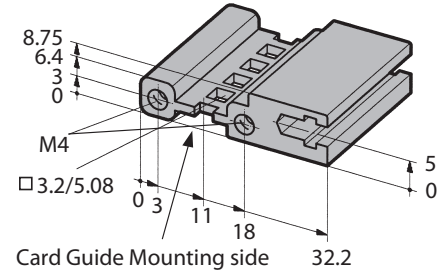
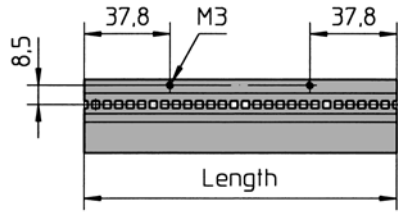

4.8.2.2 Internal Extrusion 66-194 for Conductive Backplane Mounting

Length for HP	mm	inch	Part-No. clear passivated
84	431.8	17.00	66-194-23

4.8.2.3 Internal Extrusion 66-138 for Card Guides

- For mounting card guides
- Tapped strip not required
- **Scope of delivery:**
 - 1 extrusion without assembly material

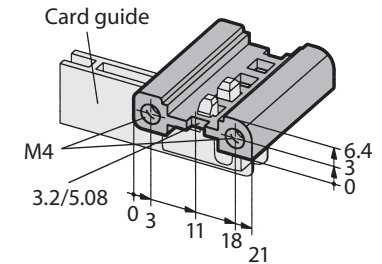
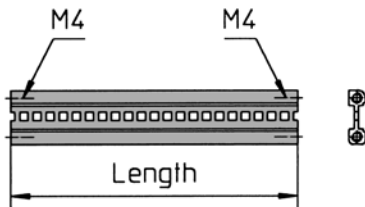

4.8.2.3. Standard Version

Length for HP	mm	inch	Part-No. clear passivated
84	431.8	17.00	66-138-23

4.8.2.5 Double Extrusion 66-192 for Insulated Backplane Mounting

- For mounting backplanes, matches 66-193, 66-288
- For use with insulating strips
- Insulating strip see 4.8.2.7
- Accept 2 x 6 mm tapped strips
- **Scope of delivery:**
 - 1 extrusion without assembly material

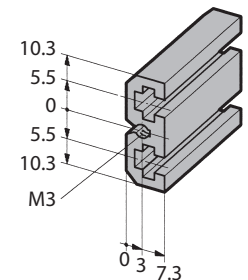

4.8.2.4 Double Extrusion 66-192 for Insulated Backplane Mounting

Length for HP	mm	inch	Part-No. clear passivated
84	426.7	16.79	66-192-23

Assembly material with adapter: 63-175 (63K175 with Torx)

4.8.2.5 Double Extrusion 66-195 for Conductive Backplane Mounting

- For mounting backplanes without insulating strips
- Matches 66-194, 66-289, 66-290
- Accept 2 x 6 mm tapped strips
- **Scope of delivery:**
 - 1 extrusion without assembly material

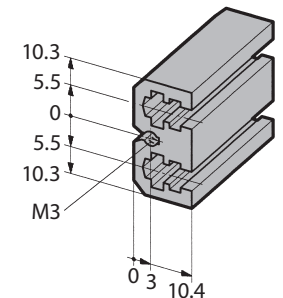

4.8.2.5 Double Extrusion 66-195 for Conductive Backplane Mounting

Length for HP	mm	inch	Part-No. clear passivated
84	426.7	16.77	66-195-23

Assembly material with adapter: 63-175 (63K175 with Torx)

4.8.2.6 Edge Connector Extrusion 66-147

- For use with extrusions for backplanes 66-193
- **Scope of delivery:**
 - Edge connector extrusion without assembly material

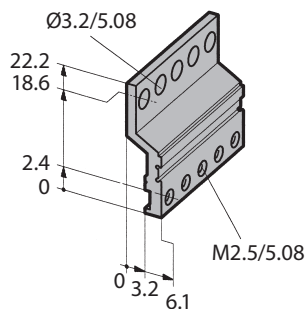
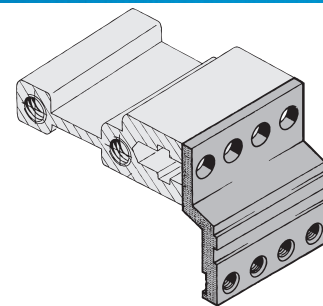

4.8.2.6 Edge Connector Extrusion

Length for HP	mm		Part-No.	
	mm	inch	clear passivated	raw
8	40.6	1.59	66-147-40	-
18	91.4	3.59	66-147-41	-
28	142.2	5.60	66-147-42	-
42	213.4	8.40	66-147-63	-
63	320.0	12.60	66-147-65	-
81	411.5	16.20	66-147-22	-
84	426.7	16.80	66-147-52	-
	1350.0	53.14	-	66-147-19

Assembly Material

Description	Part-No.
Assembly material M2.5 (for 2 supplementary extrusions)	63-214

4.8.2.7 Insulating Strips 66-901

- Plastic grey
- In use with extrusions 66-112, 66-192, 66-193, 66-288
- **Scope of delivery:**
 - 1 insulating strip without assembly material

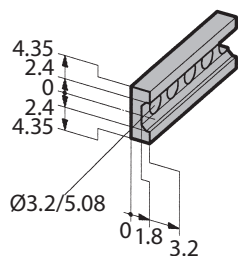

4.8.2.7 Insulating Strips 66-901

Length for HP	mm		Part-No.
mm	inch		
42	216.44	8.52	66-901-20
63	323.12	12.72	66-901-21
81	414.56	16.32	66-901-22
84	429.80	16.92	66-901-23

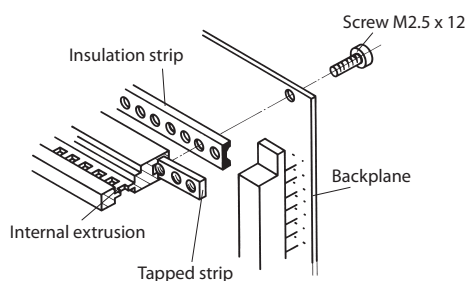

Mounting with Insulation Strips

Description	Part-No.
Cross recessed cylinderhead earthing screw M2.5 x 12	5325-12

4.8.3 Height Extrusions

4.8.3.1 Height Extrusions 19" 66-275

- 19" height extrusion type Systemkit 12K
- For standard side panel 2 mm
- Shape to direct mounting of the EMC-gasket 81-062-XX
- **Scope of delivery:**
 - 1 height extrusion without assembly material

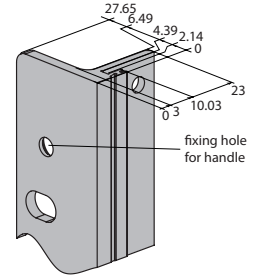

4.8.3.1 Height Extrusions 19" 66-275

Length for U	mm		Part-No. clear passivated fixing hole for handle	
	mm	inch	without	with
3	132.5	5.20	66-275-23	66-275-33
4	177.0	6.96	66-275-24	66-275-34
6	265.9	10.46	66-275-26	66-275-36
7	310.3	12.21	66-275-27	66-275-37
9	399.2	15.71	-	66-275-39

4.8.3.2 Height Extrusions 66-274

- 19" height extrusion type Systemkit 12K
- For standard side panel 2 mm
- Shape to direct mounting of the EMC-gasket 81-062-XX
- **Scope of delivery:**
 - 1 height extrusion without assembly material

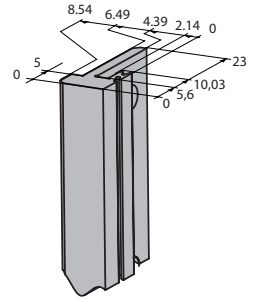

4.8.3.2 Height Extrusions 66-274

Length for U	mm		Part-No. clear passivated
	mm	inch	
3	132.5	5.20	66-274-23
4	177.0	6.96	66-274-24
6	265.9	10.46	66-274-26
7	310.3	12.21	66-274-27
9	399.2	15.71	66-274-29

4.8.3.3 Height Extrusions with Cut-out for Telescopic Rails

- 19" height extrusion type Systemkit 12K
- For standard side panel 2 mm
- Cut-out for telescopic rails
- Shape to direct mounting of the EMC-gasket 81-062-XX
- **Scope of delivery:**
 - 1 height extrusion without assembly material



4.8.3.3 Height Extrusions with Cut-out for Telescopic Rails

Length for U	mm		Part-No. clear passivated	
	mm	inch	left	right
3	132.5	5.20	66-274-63	
4	177.0	6.96	66-274-64	
6	265.9	10.46	66-274-66	66-274-76
7	310.3	12.21	66-274-67	66-274-77
9	399.2	15.71	66-274-69	66-274-79

**ELMA Electronic AG**

Hofstrasse 93, Postfach
CH-8620 Wetzikon
Phone +41 44 933 41 11
Fax +41 44 933 42 15
sales@elma.ch

**ELMA Electronic
France SA**

ZA du Buisson Rond
F-38460 Villemoirieu
Phone +33 4 37 06 21 10
Fax +33 4 37 06 21 19
sales@elma-electronic.fr

**ELMA Electronic Inc.**

44350 Grimmer Blvd.
Fremont, CA 94538
Phone +1 510 656 3400
Fax +1 510 656 3783
sales@elma.com

ELMA Bustronic Corp.

44350 Grimmer Blvd.
Fremont, CA 94538
Phone +1 510 490 7388
Fax +1 510 490 1853
sales@elmabustronic.com

**Optima EPS Corp. - an Elma
Company**

1775 MacLeod Drive
Lawrenceville, GA 30043
Phone +1 770 496 4000
Fax +1 770 496 4041
sales@elma.com

ACT/Technico

760 Veterans Circle
Warminster, PA 18974-3531
Phone +1 215 956 1200
Fax +1 215 956 1201
sales@acttechnico.com

**ELMA Electronic GmbH**

Stuttgarter Strasse 11
D-75179 Pforzheim
Phone +49 7231 97 34 0
Fax +49 7231 97 34 97
info@elma.de

**ELMA Electronic
Israel Ltd.**

34, Modi'in St.
Sgula I.Z., Petach-Tikva, 49271 IL
Phone +972 3 930 5025
Fax +972 3 931 3134
sales@elma.co.il

**ELMA Electronic UK Limited**

Solutions House
Fraser Road, Priory Business Park
Bedford, MK44 3BF
Phone +44 1234 838 822
Fax +44 1234 836 650
sales@elma-mektron.co.uk

**ELMA Electronic
Romania SRL**

Chisoda, DN 59 Km 8 + 550 m
307221 Judet Timis
Phone +40 256 306 046
Fax +40 256 249 820
info@elma.ro

**ELMA Electronic
(China) Co., Ltd.**

8F, 355, Fu Te Road (West 1)
Wai Gao Qiao Free Trade Zone
Pudong District
Shanghai, 200131, China
Phone +86 21 5866 5908
Fax +86 21 5866 5918
sales@elmachina.com

**Elma Asia Pacific Pte Ltd**

115-A Commonwealth Drive
#03-14 Tanglin Halt Industrial Estate
149596 Singapore
Phone +65 6479 8552
Fax +65 6479 8662
sales.elmaap@elma.com

Your local solution partner: