

Assembly Instructions

SMA RIGHT ANGLE SOLDER TYPE PLUG FOR SEMI-RIGID CABLE

CABLE GROUP	PART NUMBER	"A"	"B"
RG 405/u (.086 semi-rigid)	142-0693-101/106	.145 (3.68)	.075 (1.90)
RG 402/u (.141 semi-rigid)	142-0694-101/106	.170 (4.32)	.105 (2.67)

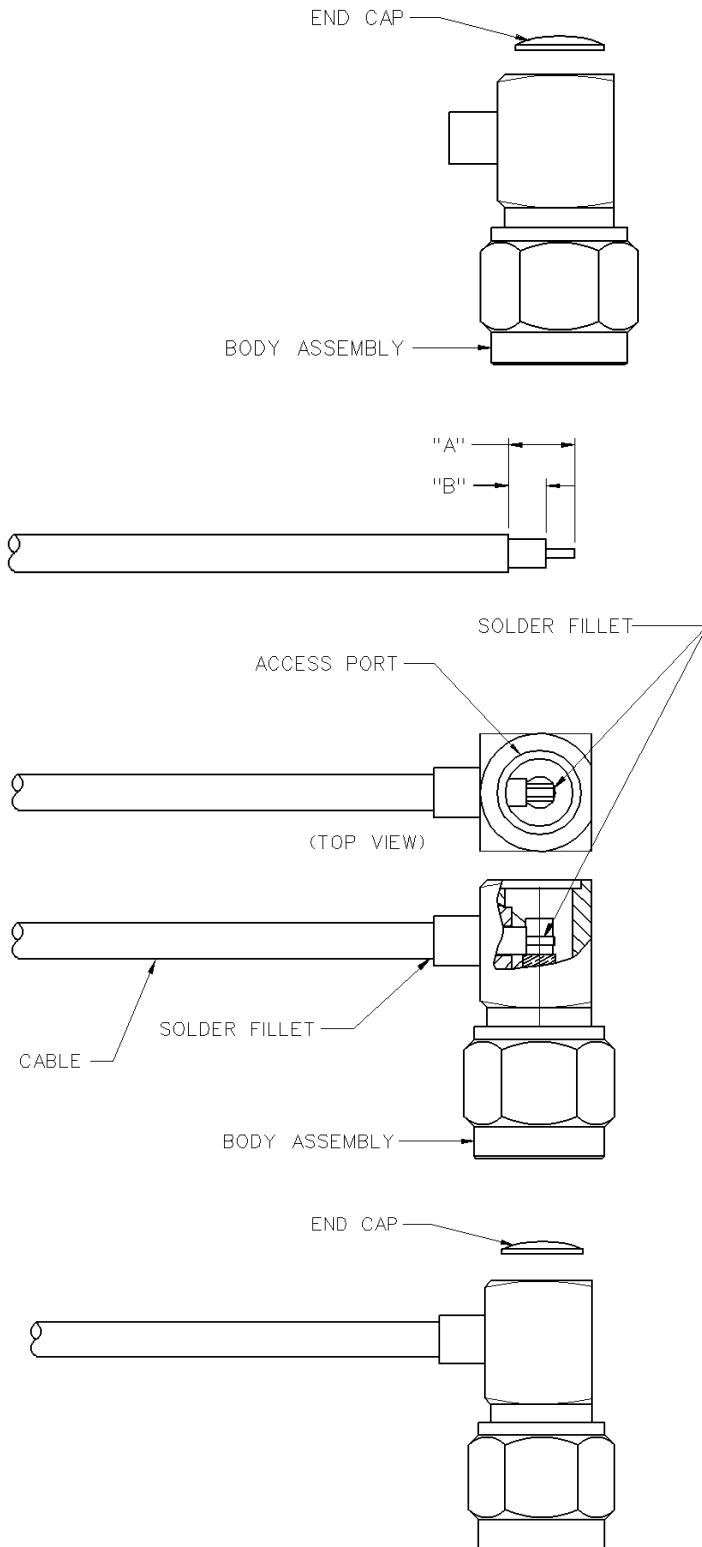

1. Identify connector parts. (2 piece parts)
2. Strip cable to dimensions shown. Do not nick center conductor during strip operations.
3. Insert cable into body making certain that the cable insulation bottoms on the center contact. Solder center conductor to contact using 60/40 tin/lead solder as shown. Use a minimum amount of solder for a good joint.
4. Solder body to cable using 60/40 tin/lead solder as shown. Use a minimum of heat to minimize cable insulation movement.
5. Press end cap into body access port using .187 (4.75) dia. flat punch.

SMA SOLDER TYPE STRAIGHT JACKS, STRAIGHT PLUGS, AND STRAIGHT BULKHEAD JACKS FOR SEMI-RIGID CABLE

CABLE GROUP	PART NUMBER	"A"
RG 405/u (.086 semi-rigid)	142-0593-001/006 142-0593-401/406 142-0693-001/006	.070 (1.78)
RG 402/u (.141 semi-rigid)	142-0594-001/006 142-0594-401/406 142-0694-001/006	.085 (2.16)

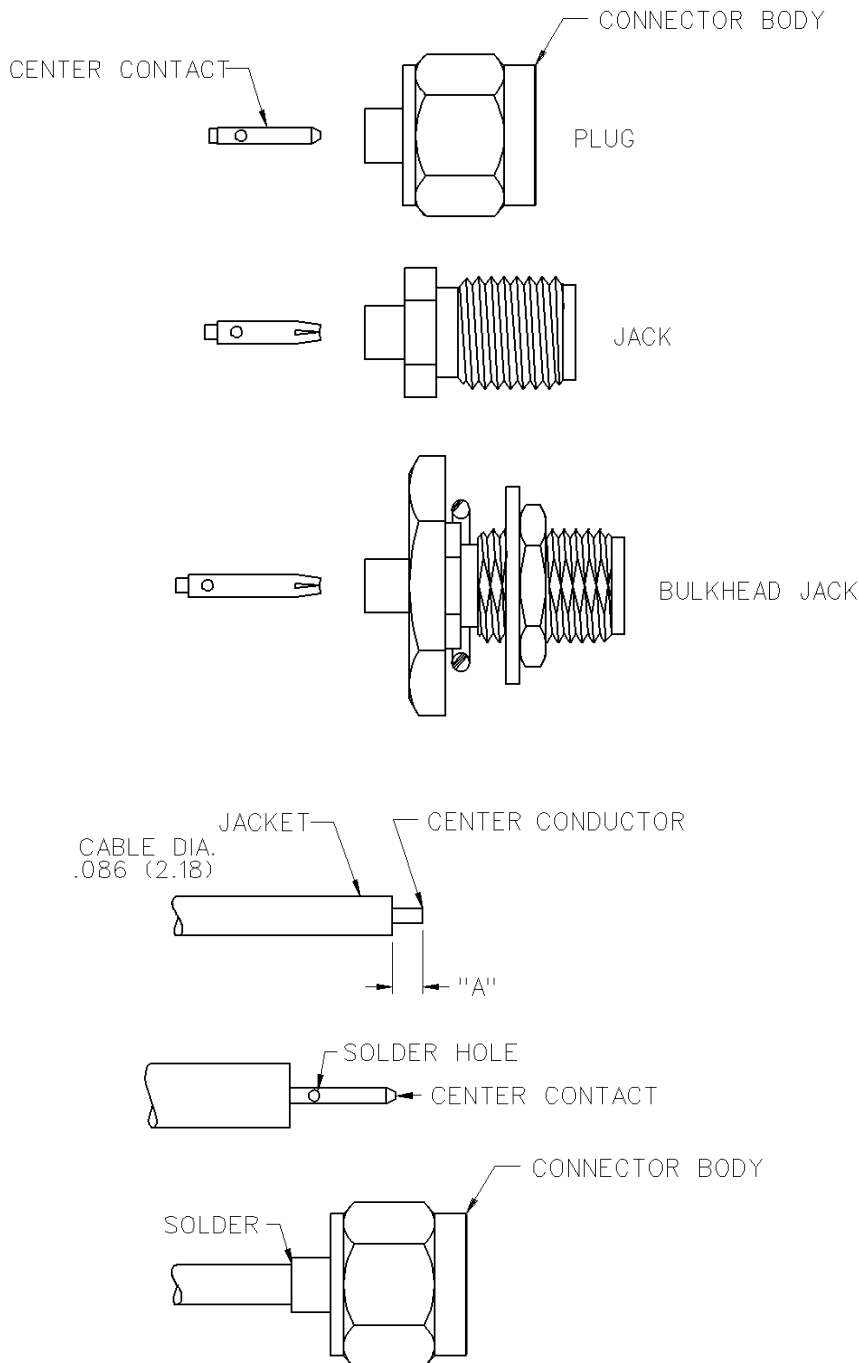

1. Identify connector parts. (2 piece parts)
2. Strip cable to dimensions shown. Do not nick center conductor.
3. Place center contact on center conductor making sure contact bottoms against cable insulation. Solder center conductor to center contact through solder hole. Solder **must not** be allowed to run on outside of contact. Use a minimum amount of solder for a good joint. **.020 (0.51) diameter solder is recommended.** Trim excess insulation.
4. Insert contact and cable into body assembly making sure cable is bottomed against insulator in body. Solder body to cable. Use a minimum amount of heat to minimize cable insulation movement.

Assembly Instructions

SMA SOLDER TYPE STRAIGHT PLUGS FOR SEMI-RIGID CABLE

CABLE GROUP	PART NUMBER
RG 402/u (.141 semi-rigid)	142-0694-011
	142-0694-016

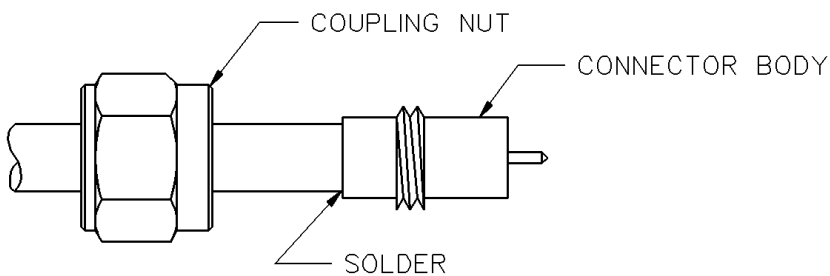
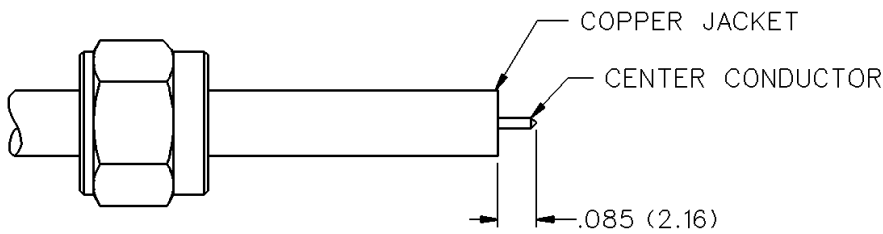
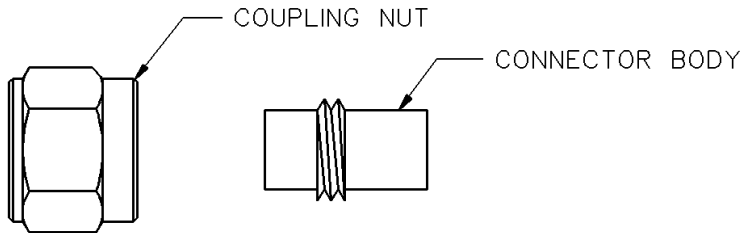

1. Identify connector parts. (2 piece parts)
2. Strip cable to dimensions shown. Do not nick center conductor. Bevel the cable center conductor per contact detail of SMA interface on page 26. Slide coupling nut onto cable as shown.
3. Insert cable into body making sure cable jacket is flush with front of body. Solder body to cable. Use a minimum amount of heat to minimize cable insulation movement. Trim expanded insulation flush with front of body or fixture body and cable during soldering to prevent cable insulation expansion.
4. Thread coupling nut over body.

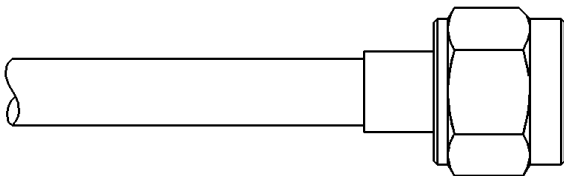

SMA SOLDER TYPE STRAIGHT PLUGS FOR SEMI-RIGID CABLE

CABLE GROUP	PART NUMBER
RG 402/u (.141 semi-rigid)	142-0694-021
	142-0694-026
	142-0694-041
	142-0694-046

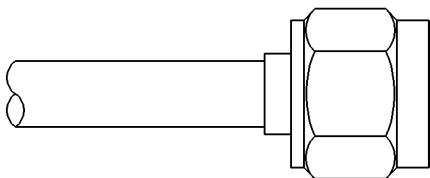
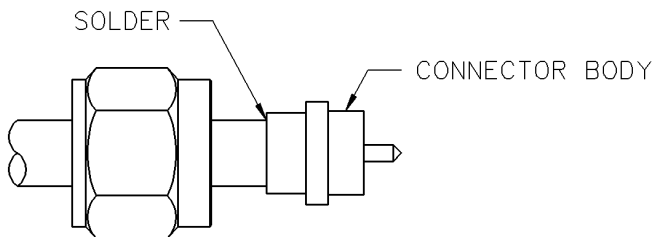
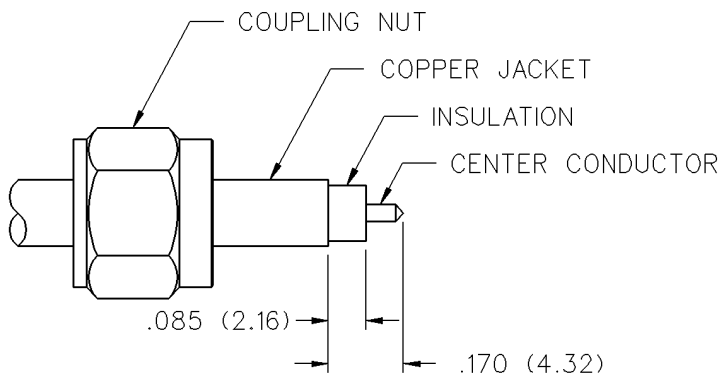
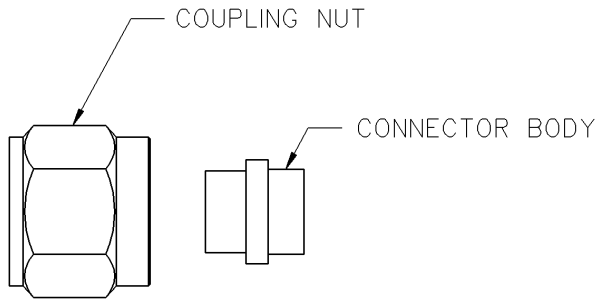

1. Identify connector parts. (2 piece parts)
2. Strip cable to dimensions shown. Do not nick center conductor. Bevel the cable center conductor per contact detail of SMA interface on page 26. Slide coupling nut onto cable as shown.
3. Insert cable into body making sure cable jacket is bottomed against shoulder inside of body. Solder body to cable. Use a minimum amount of heat to minimize cable insulation movement. Trim expanded insulation flush with front of body or fixture body and cable during soldering to prevent insulation expansion.
4. Thread coupling nut over body.

Assembly Instructions

SMA SOLDER TYPE STRAIGHT PLUGS FOR SEMI-RIGID CABLE

CABLE GROUP	PART NUMBER
RG 402/u	142-0694-031
(.141 semi-rigid)	142-0694-036

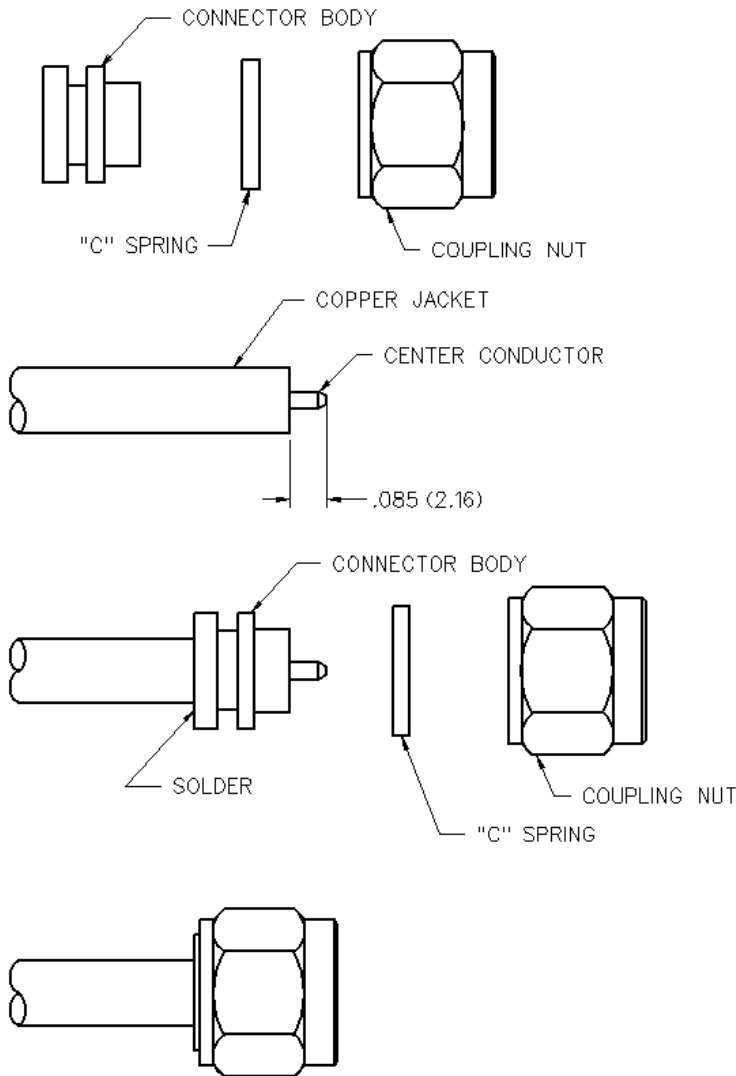

1. Identify connector parts. (3 piece parts)
2. Strip cable to dimensions shown. Do not nick center conductor. Bevel the cable center conductor per contact detail of SMA interface on page 26.
3. Insert cable into body making sure cable jacket is flush with front of body. Solder body to cable. Use a minimum amount of heat to minimize cable insulation movement. Trim expanded cable insulation flush with front of body or fixture body and cable during soldering to prevent insulation expansion.
4. Snap "C" spring onto connector body groove. Compress "C" spring using 141-0000-904 compression tool. Install coupling nut onto connector body. Nut should spin freely.

SMA SOLDER TYPE STRAIGHT PLUGS FOR SEMI-RIGID CABLE

CABLE GROUP	PART NUMBER	"A"
RG-405/u (.086 semi-rigid)	142-0693-051	.070 (1.78)
	142-0693-056	.070 (1.78)
RG-402/u (.141 semi-rigid)	142-0694-051	.085 (2.16)
	142-0694-056	.085 (2.16)

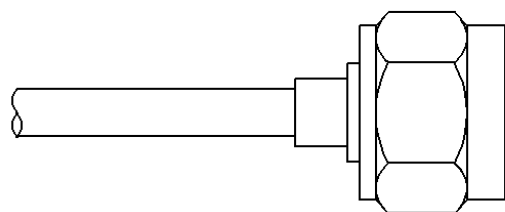
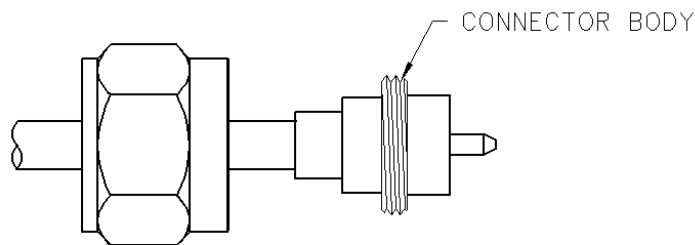
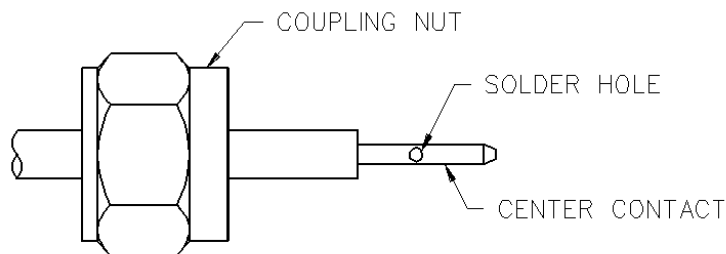
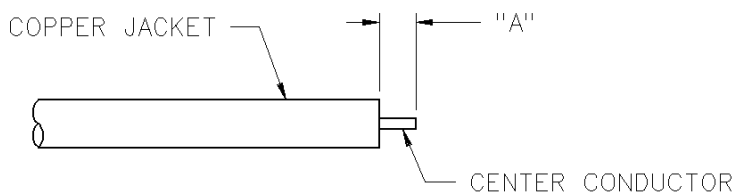
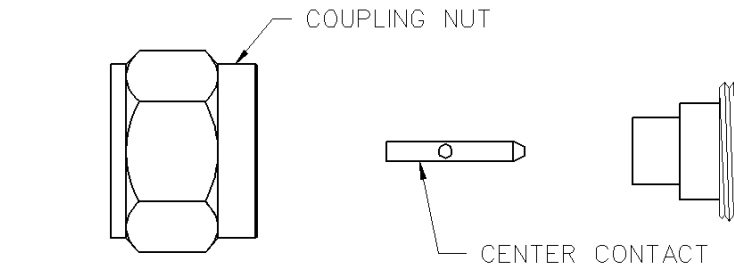

1. Identify connector parts. (3 piece parts)
2. Strip cable to dimensions shown. Do not nick center conductor. Slide coupling nut onto cable as shown.
3. Place center contact on center conductor making sure contact bottoms against cable insulation. Solder center conductor to center contact through solder hole. Solder **must not** be allowed to run on outside of contact. Use a minimum amount of solder for a good joint. **.020 (0.51) diameter solder is recommended.** Trim excess insulation.
4. Insert contact and cable into body making sure cable is bottomed against insulator in body. Solder body to cable. Use a minimum amount of heat to minimize cable insulation movement.
5. Thread coupling nut over body.

Assembly Instructions

SMA SOLDER TYPE ANTENNA CONNECTOR PLUG FOR FLEXIBLE OR SEMI-RIGID CABLE

CABLE GROUP	PART NUMBER
RG 178/u, .047 semi-rigid	142-0801-421

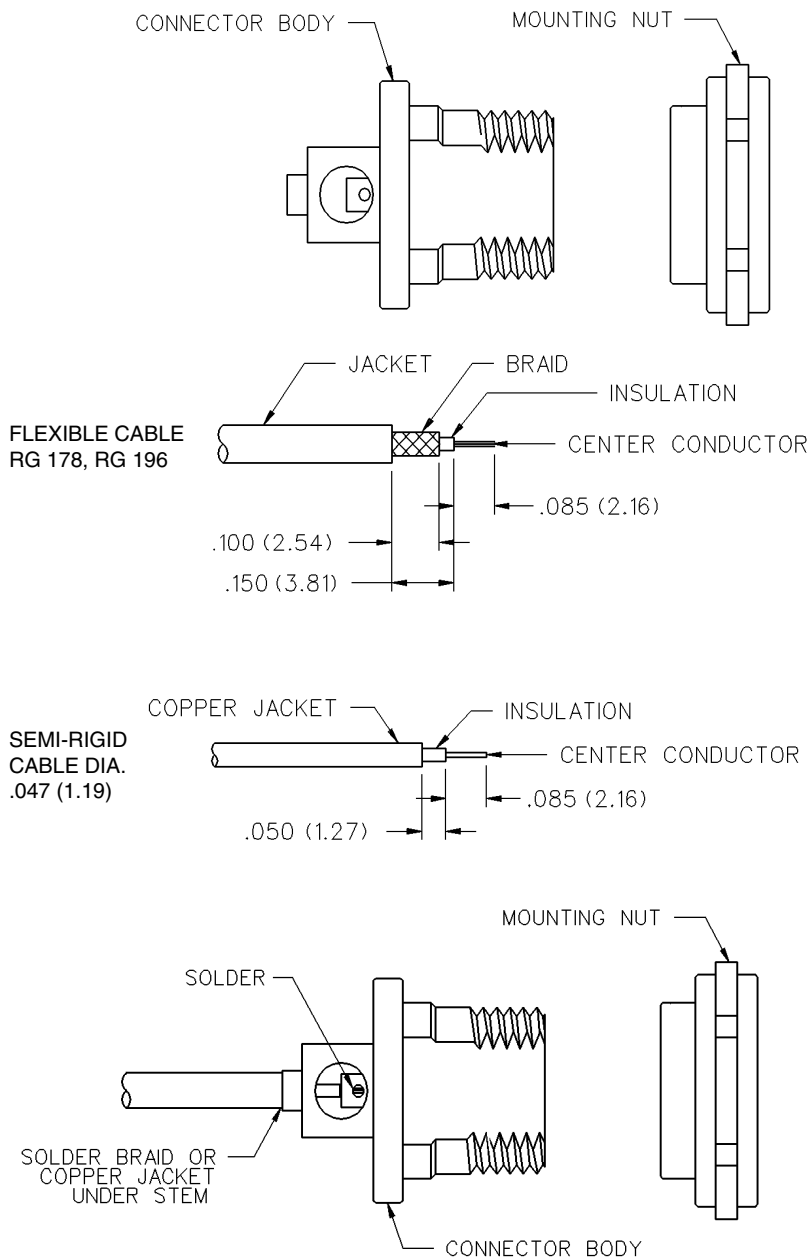

1. Identify connector parts. (2 piece parts)
2. Strip cable to dimensions shown. Do not nick center conductor or braid on flexible cable.
3. **Flexible Cable Attachment:** Twist stranded center conductor into tight bundle and tin (optional). Slide cable into body, making sure cable insulation bottoms on center contact and braid fits inside stem. Solder center conductor to contact through the side access ports. Use a minimum amount of solder for a good joint. **.020 (0.51) diameter solder is recommended.** Solder braid to body. Use a minimum amount of solder to completely join the braid to the body. **Semi-Rigid Cable Attachments:** Slide cable into body making certain cable insulation bottoms on center contact. Solder center conductor to contact through the side access ports. Use a minimum amount of solder for a good joint. **.020 (0.51) diameter solder is recommended.** Solder body to cable jacket. Use a minimum amount of heat to minimize cable insulation movement.

SMA 3-PIECE PLUG, JACK AND BULKHEAD JACK FOR RG 178 FLEXIBLE CABLE

CABLE GROUP	PART NUMBER	CRIMP HEX
RG 178/u, 196	142-0402-011	.105 (2.67)
	142-0402-016	.105 (2.67)
	142-0302-011	.105 (2.67)
	142-0302-016	.105 (2.67)
	142-0302-431	.105 (2.67)
	142-0302-436	.105 (2.67)

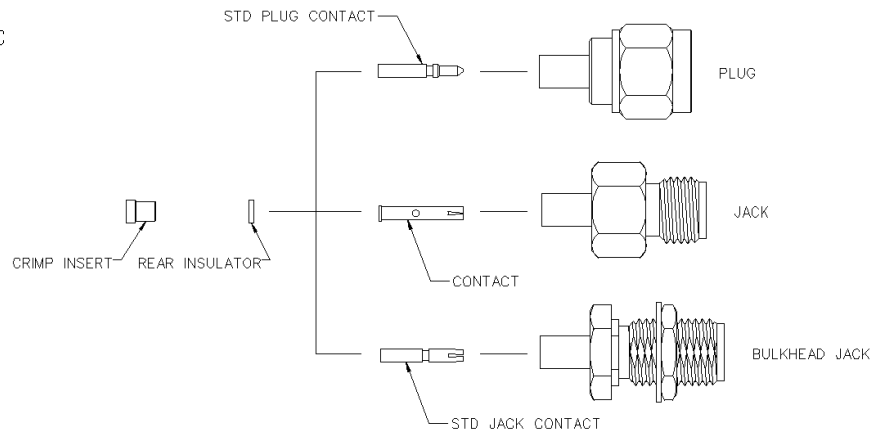
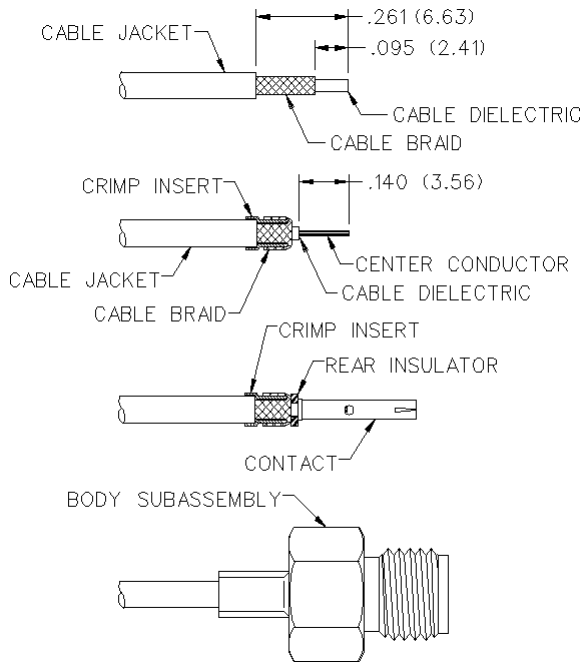

1. Identify piece parts. (4 piece parts plus nut and washer for bulkhead.)
2. Strip cable jacket and braid to dimensions shown. Do not nick braid during strip operations.
3. Slide crimp insert over braid and against jacket. Fold braid around crimp insert as shown. Strip dielectric to dimension shown. If cable is being manually stripped the rear insulator can be assembled and used as a guide. Do not nick center conductor during strip operation. Tin center conductor if contact is to be solder attached. Do not tin center conductor if contact is to be crimp attached.
4. Assemble rear insulator over cable dielectric and contact over center conductor as shown.
Solder attachment: Solder contact to center conductor using 60/40 tin/lead solder. Care should be taken that excess solder is not applied.
Crimp attachment: Crimp contact to center conductor using production tooling or hand tool 144-0000-910, setting #2 with positioner 141-0000-907. Crimp location should be centered between end of contact and x-hole. Crimp attachment to solid center conductor cables is not recommended.
5. Slide body assembly over contact, rear insulator and crimp insert. Crimp body using recommended crimp tool. Maintain forward pressure on cable while crimping.
 Body crimp die hex: .105 (2.67) hex

Assembly Instructions

SMA TYPE STRAIGHT PLUGS, STRAIGHT JACKS, AND STRAIGHT BULKHEAD JACKS FOR FLEXIBLE CABLE - CRIMP OR SOLDER CONTACTS

1. Identify connector parts. (3 piece parts - except bulkhead)
2. Strip cable to dimensions shown. Do not nick braid or center conductor. Tin center conductor if contact will be solder attached. Do not tin center conductor if contact is to be crimp attached. When stripping LMR-100 low loss cable, remove foil back to where cable jacket is stripped. A wire stripper of correct size is recommended for this step. Slide heat shrink (as applicable) and crimp sleeve onto jacket of cable.
3. Assemble contact onto cable as shown.
Solder Attachment: Solder contact to center conductor through solder hole using .020 (0.51) diameter solder. Use a minimum amount of solder for a good joint.
Crimp Attachment: Crimp contact to center conductor using JCI Hand Tool 144-0000-910, setting #2, with positioner 141-0000-907. Crimp location should be centered between end of contact and X-hole. Crimp attachment to solid center conductor cables is not recommended.
4. Flare braid and slide body assembly over contact and under braid. Then seat body assembly firmly onto contact. The cable may have to be held in a clamping fixture. Arrange braid uniformly around crimp stem. Slide crimp sleeve forward and crimp using recommended crimp tool. Slide heat shrink forward and shrink (as applicable).

CABLE GROUP	PART NUMBER	CRIMP HEX
RG 316/u, 161, 174, 188; LMR-100	142-0303-011/016	.128 (3.25)
	142-0303-411/416	.128 (3.25)
RG 316DS, 188DS	142-0304-011/016	.151 (3.83)
	142-0304-411/416	.151 (3.83)
RG 58/u, 141, 303	142-0307-011/016	.213 (5.41)
	142-0307-411/416	.213 (5.41)
RG 55/u, 142, 223, 400	142-0308-011/016	.213 (5.41)
	142-0308-411/416	.213 (5.41)
RG 179/u, 187	142-0333-011/016	.128 (3.25)
	142-0333-411/416	.128 (3.25)
RG 316/u, 161, 174, 188; LMR-100	142-0403-011/016	.128 (3.25)
RG 316DS, 188DS	142-0404-011/016	.151 (3.83)
RG 58/u, 141, 303	142-0407-011/016	.213 (5.41)
RG 55/u, 142, 223, 400	142-0408-011/016	.213 (5.41)
RG 179/u, 187	142-0433-011/016	.128 (3.25)
RG 316/u, 161, 174, 188; LMR-100	142-2403-001/006	.128 (3.25)
RG 316DS, 188DS	142-2404-001/006	.151 (3.83)
RG 316/u, 161, 174, 188; LMR-100	142-4303-401/406	.128 (3.25)
RG 316DS, 188DS	142-4304-401/406	.151 (3.83)
RG 58/u, 141, 303	142-4307-401/406	.213 (5.41)
RG 55/u, 142, 223, 400	142-4308-401/406	.213 (5.41)
RG 316/u, 161, 174, 188; LMR-100	142-4403-001/006	.128 (3.25)
RG 316DS, 188DS	142-4404-001/006	.151 (3.83)
RG 58/u, 141, 303	142-4407-001/006	.213 (5.41)
RG 55/u, 142, 223, 400	142-4408-001/006	.213 (5.41)
RG 316/u, 161, 174, 188; LMR-100	142-5303-401/406	.128 (3.25)
RG 316DS, 188DS	142-5304-401/406	.151 (3.83)
RG 58/u, 141, 303	142-5307-401/406	.213 (5.41)
RG 55/u, 142, 223, 400	142-5308-401/406	.213 (5.41)
RG 316/u, 161, 174, 188; LMR-100	142-5403-001/006	.128 (3.25)
RG 316DS, 188DS	142-5404-001/006	.151 (3.83)
RG 58/u, 141, 303	142-5407-001/006	.213 (5.41)
RG 55/u, 142, 223, 400	142-5408-001/006	.213 (5.41)

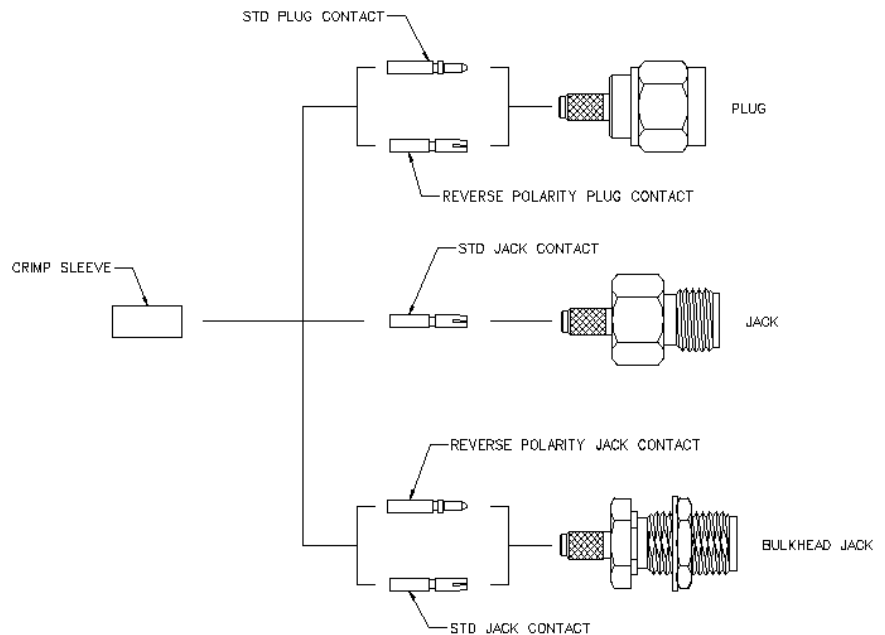
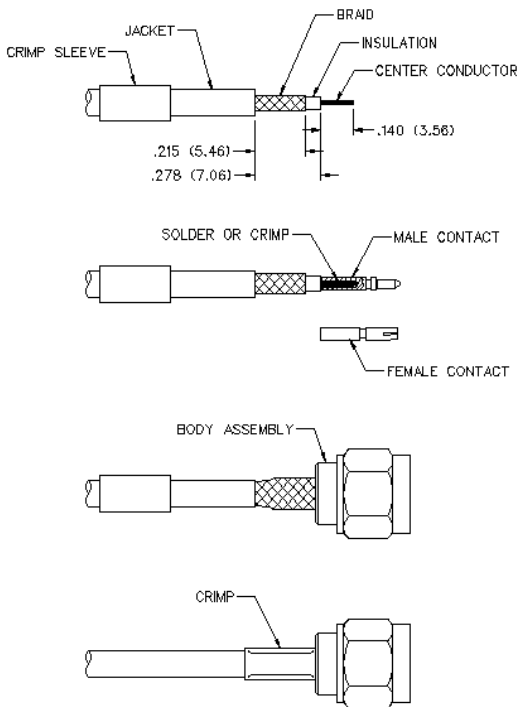

STRAIGHT SMA LOW LOSS DIAMETER 195, .200 AND .240 STRAIGHT TYPE PLUGS

CABLE GROUP	PART NUMBER	CRIMP HEX
LMR-195	142-0307-411	.213 (5.41)
	142-0307-416	.213 (5.41)
LMR-240	142-0335-401	.240 (6.10)
	142-0335-406	.240 (6.10)
LMR-200	142-0339-401	.213 (5.41)
	142-0339-406	.213 (5.41)
LMR-195	142-0407-011	.213 (5.41)
	142-0407-016	.213 (5.41)
LMR-240	142-0435-001	.240 (6.10)
	142-0435-006	.240 (6.10)
LMR-200	142-0439-001	.213 (5.41)
	142-0439-006	.213 (5.41)
LMR-240	142-4435-001	.240 (6.10)
	142-4435-006	.240 (6.10)
LMR-200	142-4439-001	.213 (5.41)
	142-4439-006	.213 (5.41)
LMR-195	142-4407-001	.213 (5.41)
	142-4407-006	.213 (5.41)
LMR-240	142-5435-001	.255 (6.48)
	142-5435-006	.255 (6.48)
LMR-200	142-5439-001	.213 (5.41)
	142-5439-006	.213 (5.41)
LMR-195	142-5407-001	.213 (5.41)
	142-5407-006	.213 (5.41)

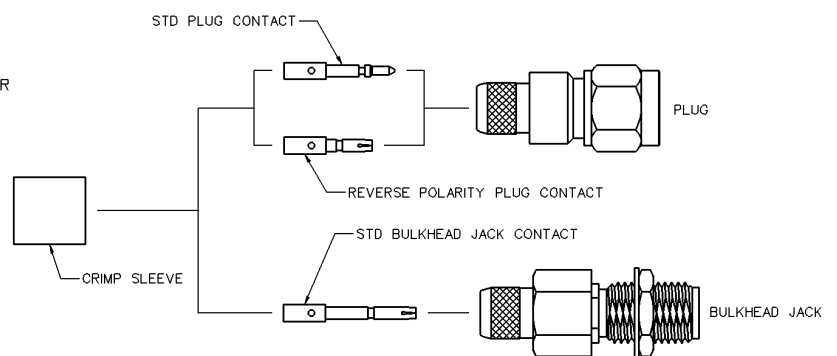
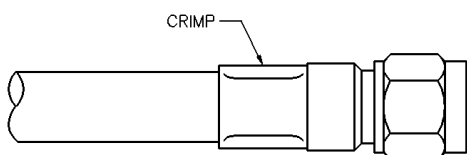
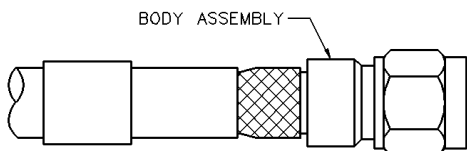
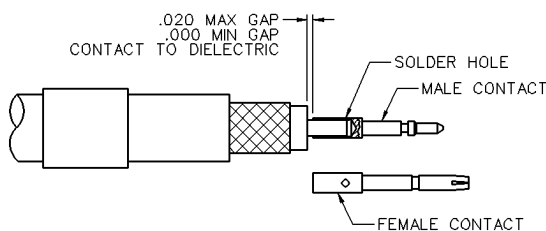
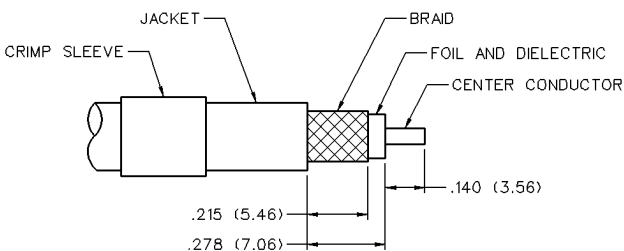

1. Identify connector parts. (3 piece parts - except bulkhead)
2. Strip cable to dimensions shown. Do not nick braid, foil or center conductor. Cut foil flush with dielectric, do not remove foil. Make sure that dielectric is clean and free from all particles. Tin center conductor, keeping solder amount to a minimum. Slide crimp sleeve onto jacket of cable.
3. Assemble contact onto cable as shown. Position contact such that a gap of no more than .020 (0.51) is kept between dielectric and contact. Solder contact to center conductor through solder hole using .020 (0.51) Diameter solder. Use a minimum amount of solder for a good joint. Do not allow contact to move into dielectric during soldering process.
4. Flare braid and slide body assembly over contact, foil and dielectric, then under braid. Seat body assembly firmly onto contact. Arrange braid uniformly around crimp stem. Slide crimp sleeve forward and crimp using Johnson Components® hand crimp tool 141-0000-913 and recommended crimp die hex.

Assembly Instructions

SMA CRIMP TYPE STRAIGHT PLUGS, STRAIGHT JACKS, AND STRAIGHT BULKHEAD JACKS FOR FLEXIBLE CABLE

CABLE GROUP	PART NUMBER	CRIMP HEX
RG 178/u, 196	142-0302-001	.105 (2.67)
	142-0302-006	.105 (2.67)
RG 316/u, 161, 174, 188	142-0303-001	.128 (3.25)
	142-0303-006	.128 (3.25)
RG 316DS, 188DS	142-0304-001	.151 (3.83)
	142-0304-006	.151 (3.83)
RG 58/u, 141, 303	142-0307-001	.213 (5.41)
	142-0307-006	.213 (5.41)
RG 55/u, 142, 223, 400	142-0308-001	.213 (5.41)
	142-0308-006	.213 (5.41)
RG 178/u, 196	142-0302-401	.105 (2.67)
	142-0302-406	.105 (2.67)
RG 316/u, 161, 174, 188	142-0303-401	.128 (3.25)
	142-0303-406	.128 (3.25)
RG 316DS, 188DS	142-0304-401	.151 (3.83)
	142-0304-406	.151 (3.83)
RG 58/u, 141, 303	142-0307-401	.213 (5.41)
	142-0307-406	.213 (5.41)
RG 55/u, 142, 223, 400	142-0308-401	.213 (5.41)
	142-0308-406	.213 (5.41)
RG 178/u, 196	142-0402-001	.105 (2.67)
	142-0402-006	.105 (2.67)
RG 316/u, 161, 174, 188	142-0403-001	.128 (3.25)
	142-0403-006	.128 (3.25)
RG 316DS, 188DS	142-0404-001	.151 (3.83)
	142-0404-006	.151 (3.83)
RG 58/u, 141, 303	142-0407-001	.213 (5.41)
	142-0407-006	.213 (5.41)
RG 55/u, 142, 223, 400	142-0408-001	.213 (5.41)
	142-0408-006	.213 (5.41)

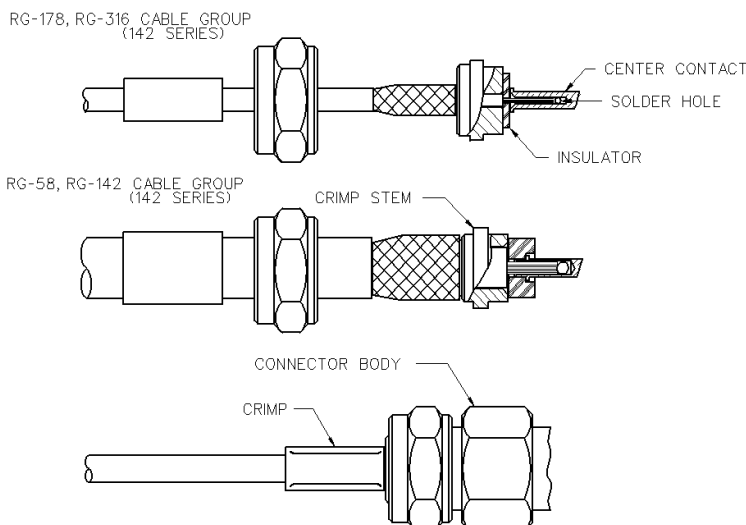
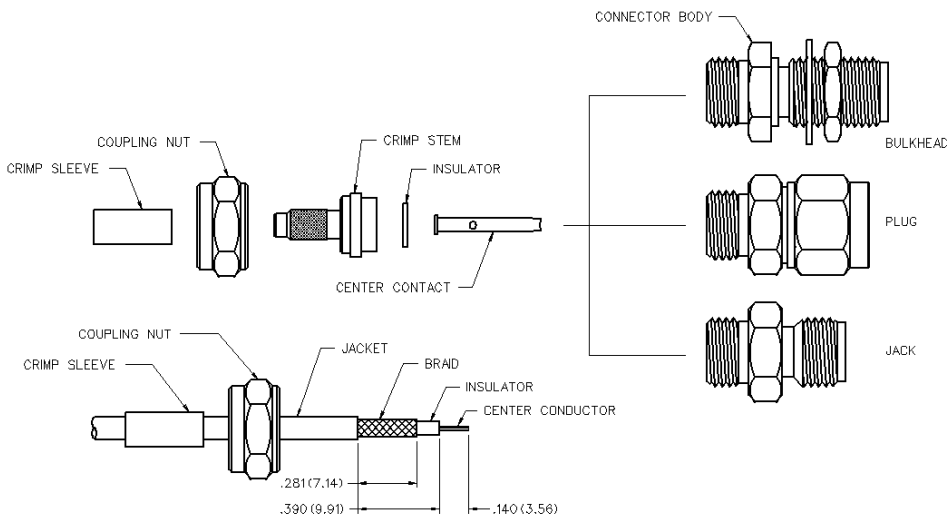

1. Identify connector parts. (6 piece parts - except bulkhead)
2. Strip cable to dimensions shown. Do not nick braid or center conductor. A wire stripper of correct size is recommended for this step. Twist stranded center conductor into tight bundle and tin (optional). Slide crimp sleeve, nut and heat shrink tubing (as applicable) onto cable as shown.
3. Flare braid and slide cable into crimp stem. Place rear insulator and center contact over center conductor and position as shown for different cable sizes. Solder center conductor to contact through the solder hole. Solder **must not** be allowed to gather and run on outside of contact. Use a minimum amount of solder for a good joint. **.020 (0.51) diameter solder is recommended.**
4. Arrange braid uniformly around crimp stem. Slide crimp sleeve over braid and crimp securely using recommended crimp tool. Slide center contact assembly into connector body. Thread coupling nut onto body and tighten to 10 in.-lb. torque. Slide heat shrink forward and shrink (as applicable).

SMA CRIMP TYPE RIGHT ANGLE PLUGS FOR FLEXIBLE CABLE

CABLE GROUP	PART NUMBER	CRIMP HEX
RG 178/u, 196	142-0402-101	.105 (2.67)
	142-0402-106	.105 (2.67)
RG 316/u, 161, 174, 188; LMR-100	142-0403-101	.128 (3.25)
	142-0403-106	.128 (3.25)
RG 316DS, 188DS	142-0404-101	.151 (3.83)
	142-0404-106	.151 (3.83)
RG 58/u, 141, 303	142-0407-101	.213 (5.41)
	142-0407-106	.213 (5.41)
RG 55/u, 142, 223, 400	142-0408-101	.213 (5.41)
	142-0408-106	.213 (5.41)
RG 179/u, 187	142-0433-101	.128 (3.25)
	142-0433-106	.128 (3.25)
RG 316/u, 161, 174, 188; LMR-100	142-4403-101	.128 (3.25)
	142-4403-106	.128 (3.25)
RG 316DS, 188DS	142-4404-101	.151 (3.83)
	142-4404-106	.151 (3.83)
RG 58/u, 141, 303	142-4407-101	.213 (5.41)
	142-4407-106	.213 (5.41)
RG 55/u, 142, 223, 400	142-4408-101	.213 (5.41)
	142-4408-106	.213 (5.41)
RG 316/u, 161, 174, 188; LMR-100	142-5403-101	.128 (3.25)
	142-5403-106	.128 (3.25)
RG 316DS, 188DS	142-5404-101	.151 (3.83)
	142-5404-106	.151 (3.83)
RG 58/u, 141, 303	142-5407-101	.213 (5.41)
	142-5407-106	.213 (5.41)
RG 55/u, 142, 223, 400	142-5408-101	.213 (5.41)
	142-5408-106	.213 (5.41)

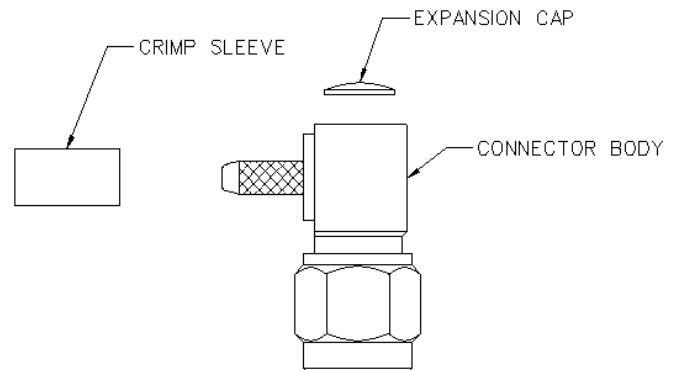
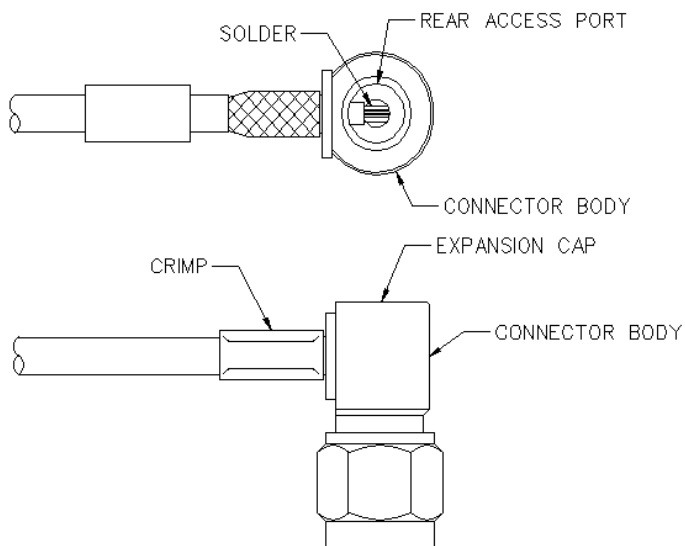
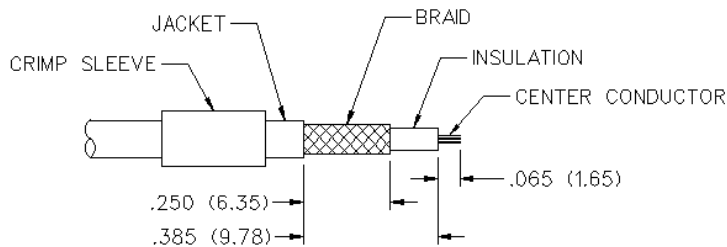

1. Identify connector parts. (3 piece parts)
2. Strip cable to dimensions shown. Do not nick braid or center conductor. When stripping LMR-100 low loss cable, remove foil back to where cable jacket is stripped. A wire stripper of correct size is recommended for this step. Twist stranded center conductor into tight bundle and tin (optional). Slide crimp sleeve onto cable as shown.
3. Flare braid and slide cable into body making certain that the cable insulation bottoms on center contact. Solder center conductor to contact through the rear access port. Use a minimum amount of solder for a full fillet joint. **.020 (0.51) diameter solder is recommended.**
4. Arrange braid uniformly around crimp stem. Slide crimp sleeve over braid and crimp securely using recommended crimp tool. Place expansion cap in access port and seat with .187 (4.75) diameter flat punch. Shrink heat shrink tubing over crimp sleeve if applicable.

Assembly Instructions

Right Angle SMA Low Loss Diameter .195, .200 and .240

CABLE GROUP	PART NUMBER	CRIMP HEX
LMR-195	142-0407-101	.213 (5.41)
	142-0407-106	.213 (5.41)
LMR-200	142-4439-101	.213 (5.41)
	142-4439-106	.213 (5.41)
LMR-240	142-0435-101	.240 (6.10)
	142-0435-106	.240 (6.10)
LMR-195	142-5407-101	.213 (5.41)
	142-5407-106	.213 (5.41)
LMR-200	142-0439-101	.213 (5.41)
	142-0439-106	.213 (5.41)
LMR-240	142-5435-101	.240 (6.10)
	142-5435-106	.240 (6.10)
LMR-195	142-4407-101	.213 (5.41)
	142-4407-106	.213 (5.41)
LMR-200	142-5439-101	.213 (5.41)
	142-5439-106	.213 (5.41)
LMR-240	142-4435-101	.240 (6.10)
	142-4435-106	.240 (6.10)

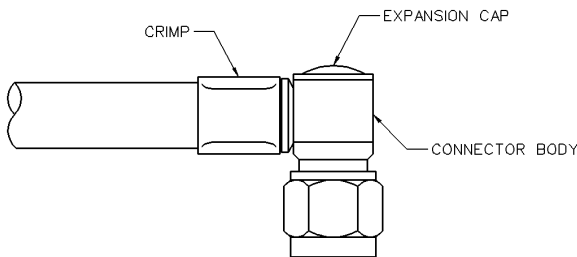
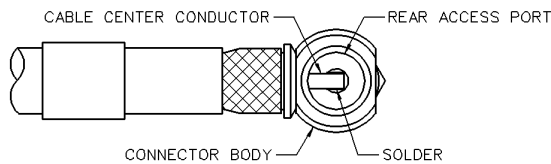
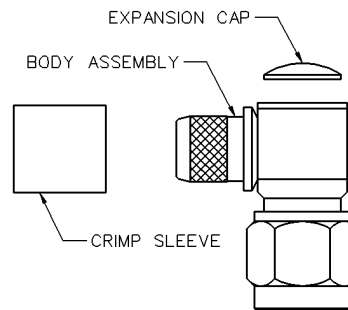
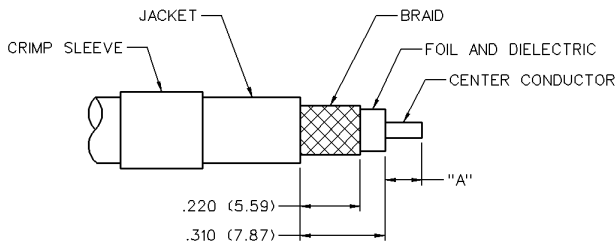

1. Identify connector parts. (3 piece parts)
2. Strip cable to dimensions shown. Do not nick braid, foil or center conductor. Cut foil flush with dielectric, do not remove foil. Make sure that dielectric is clean and free from all particles. Tin center conductor, keeping solder amount to a minimum. Slide crimp sleeve onto jacket of cable.
3. Flare braid and slide body assembly over foil and dielectric, then under braid. Make sure cable center conductor is contained within connector contact, but do not allow foil and dielectric to enter body access port. Solder center conductor to contact through the rear access port. Use a minimum amount of solder for a full fillet joint. .020 (0.51) Diameter solder is recommended.
4. Arrange braid uniformly around crimp stem. Slide crimp sleeve forward and crimp using JCI hand crimp tool 141-0000-913 and recommended crimp die hex. Place expansion cap in access port and seat with recommended Diameter flat punch.

Low Loss Dia.	"A"	Crimp Die Hex	Flat Punch Dia.
0.195	.110 (2.79)	.213 (5.41) hex	.187 (4.75)
0.200	.110 (2.79)	.213 (5.41) hex	.187 (4.75)
0.240	.135 (3.43)	.255 (6.48) hex	.242 (6.15)

SMA CLAMP TYPE STRAIGHT PLUGS, STRAIGHT JACKS, AND STRAIGHT BULKHEAD JACKS FOR FLEXIBLE CABLE

1. Identify connector parts. (6 piece parts - except bulkhead)
2. Strip cable to dimensions shown. Do not nick braid or center conductor. A wire stripper of correct size is recommended for this step. Twist stranded center conductor into tight bundle and tin (optional). Slide clamp nut and clamp cone onto cable as shown. Clamp cone must be oriented as shown for each size of cable. The RG 58/142 clamp cone slides over braid and against jacket.
3. Flare braid and slide cable into clamp stem. Place rear insulator and center contact over center conductor and position as shown for different cable sizes. Solder center conductor to contact through the solder hole. Solder **must not** be allowed to gather and run on outside of contact. Use a minimum amount of solder for a good joint. **.020 (0.51) diameter solder is recommended.**
4. Arrange braid uniformly around clamp stem. Slide center contact assembly into body. Slide clamp nut against clamp cone and braid and tighten to 10 in.-lb. torque.

CABLE GROUP	PART NUMBER	"A"	"B"	"C"	CRIMP HEX
RG 178/u, 196	142-0202-011/016	.133 (3.38)	.053 (1.35)	.085 (2.16)	.105 (2.67)
RG 161/u, 174, 188, 316	142-0203-011/016	.133 (3.38)	.053 (1.35)	.085 (2.16)	.128 (3.25)
RG 58/u, 141, 303	142-0207-011/016	.285 (7.24)	.165 (4.19)	NONE	.213 (5.41)
RG-142, 223, 55, 400	142-0207-011/016	.285 (7.24)	.165 (4.19)	NONE	.213 (5.41)
RG 178/u, 196	142-0102-011/016				.105 (2.67)
RG 161/u, 174, 188, 316	142-0103-011/016				.128 (3.25)
RG 58/u, 141, 303	142-0107-011/016	.285 (7.24)	.165 (4.19)	NONE	.213 (5.41)
RG-142, 223, 55, 400	142-0107-011/016	.285 (7.24)	.165 (4.19)	NONE	.213 (5.41)
RG 178/u, 196	142-0102-401/406				.105 (2.67)
RG 161/u, 174, 188, 316	142-0103-401/406				.128 (3.25)
RG 58/u, 141, 303	142-0107-401/406	.225 (5.72)	.145 (3.68)	NONE	.213 (5.41)
RG-142, 223, 55, 400	142-0107-401/406	.285 (7.24)	.165 (4.19)	NONE	.213 (5.41)

