

D-Sub Right Angle DIP Termination

17LE Series

DDK Ltd.



17LE-13150-27-FA

17LE-23250-27-FA

17LE-13370-27-FA

FEATURES

- 17LE series are connected to a circuit by through hole DIP solder termination style mounting on PCB and fastened on the bracket by stud or jack socket.
- Number of contact : 9, 15, 25 and 37
- Studs and hex nuts are available to fasten with mating half. This connection with PCB and metal shell is grounding and improving the resistance against EMI.
- The metal shell is in Nickel plating. The pin connectors of metal shell are beat-finished.
- 4 types of ground tabs are mountable on the bracket for protection against EMI.

SPECIFICATIONS

Rated Voltage	300V AC (r.m.s.)
Rated Current	5A / Contact
Dielectric Withstanding Voltage	1000V AC (r.m.s.) / 1 minute
Insulation Resistance	1000M Ω (min.) at 500V DC
Contact Resistance	15m Ω (max.)
Operating Temperature	-25°C ~ 85°C

MATERIAL / FINISH



Item	Material / Finish
Insulator	Polyamide Resin (UL94V-0) / Black
Shell	Steel / Ni Plating
Contact	Copper Alloy / Contact Area: Au(0.4 μ m) over Ni Plating Tail Area: Sn-Ag Plating over Ni Plating
Eyelet	Brass / Ni Plating

© Specifications and/or dimensions in this catalogue are subject to change without notice.
Your catalogue checking the latest specifications with our drawings would be highly appreciated.

▶ Right Angle Socket Connectors

17LE-13250-27(D3AB)-FA

Mating Style
1: Socket Connector

Shell Plating
3: Ni Plating

Number of Contact
9, 15, 25, 37

Key Position
0: No Key

Contact Tail Style
2: Right Angle DIP Termination

Contact Plating
7: Contact Area: Au(0.4 μ m) over Ni Plating
Tail Area: Sn-Ag over Ni Plating

FA: Lead Free

Deviation
※ Regarding the combinations of grounding tab, stud and jack socket, please refer to the list on page 6.

No Digit: Connector Only
(D3AB)

Grounding Tab (Please refer to page 4.)
No Digit: Less Grounding Tab
B : with Ground Tab 17L-004B
C : with Board Lock 17L-004C-FA
D : with Ground Tab 17L-004D
H/K: with Board Lock 17L-004E-FA
※ Ground tab B and D can not be combined with stud.

Thread Size
A : M2.6×0.45
B : M3×0.5
C : # 4-40UNC

2: with Stud Type1 (17L-002 □)
3: with Jack Socket Type 2 (17L-003 □ 1)
4: with Jack Socket Type 3 (17L-003 □ 3)
□ : Thread Type A, B, C

17LE-13xx0-27(D3xx)-FA

Socket Connector

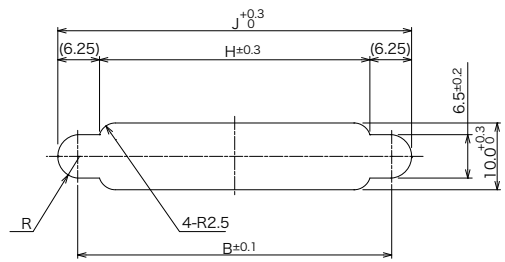
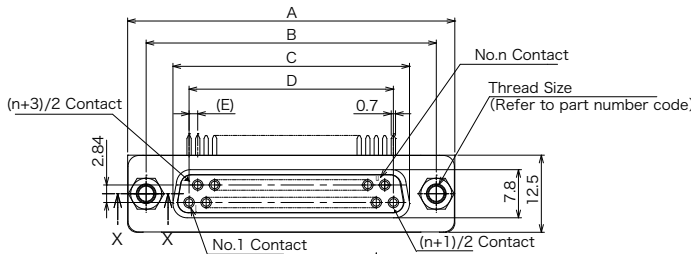

Panel Mounting Dimensions(Rear Mounting)

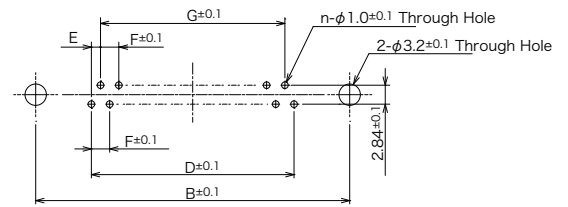
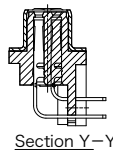
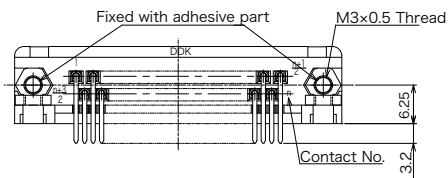
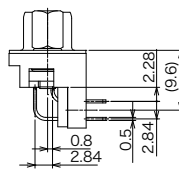
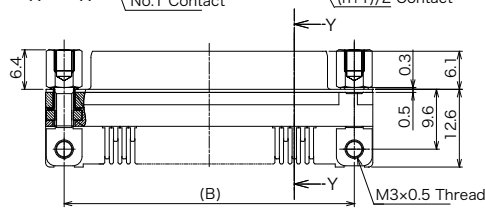

PCB Mounting Dimensions
(Applicable PCB Thickness: t = 1, 6±0.19)
(View from mounting pattern side)

Number of Contact	A	B	C	D	E	F	G	H	J
9	30.80	24.99	16.30	10.98	1.37	2.74	8.22	18.50	31.00
15	39.10	33.32	24.64	19.20	1.37	2.74	16.44	26.80	39.30
25	53.04	47.04	38.35	33.12	1.38	2.76	30.36	40.70	53.20
37	69.32	63.50	54.80	49.68	1.38	2.76	46.92	57.00	69.50

© Specifications and/or dimensions in this catalogue are subject to change without notice.
Your catalogue checking the latest specifications with our drawings would be highly appreciated.

▶ Right Angle Plug Connectors

17LE-23250-27(D3AB)-FA

FA: Lead Free

Connector Type
2: Plug Connector

Shell Plating
3: Ni Plating

Number of Contact
9, 15, 25, 37

Key Position
0: No Key

Contact Tail Style
2: Right Angle DIP Termination

Contact Plating
7: Contact Area: Au(0.4 μm) over Ni Plating
Tail Area: Sn-Ag over Ni Plating

Deviation
※ Regarding the combinations of grounding tab, stud and jack socket, please refer to the list on page 6.
No Digit: Connector Only
(D3AB)

Grounding Tab (Please refer to page 4.)
No Digit: Less Grounding Tab
B : with Ground Tab 17L-004B
C : with Board Lock 17L-004C-FA
D : with Ground Tab 17L-004D
H/K: with Board Lock 17L-004E-FA
※ Ground tab B and D can not be combined with stud.

Thread Size
A : M2.6×0.45
B : M3×0.5
C : # 4-40UNC

2: with Stud Type1 (17L-002 □)
3: with Jack Socket Type 2 (17L-003 □ 1)
4: with Jack Socket Type 3 (17L-003 □ 3)
□ : Thread Type A, B, C

17LE-23xx0-27(D3xx)-FA

Plug Connector

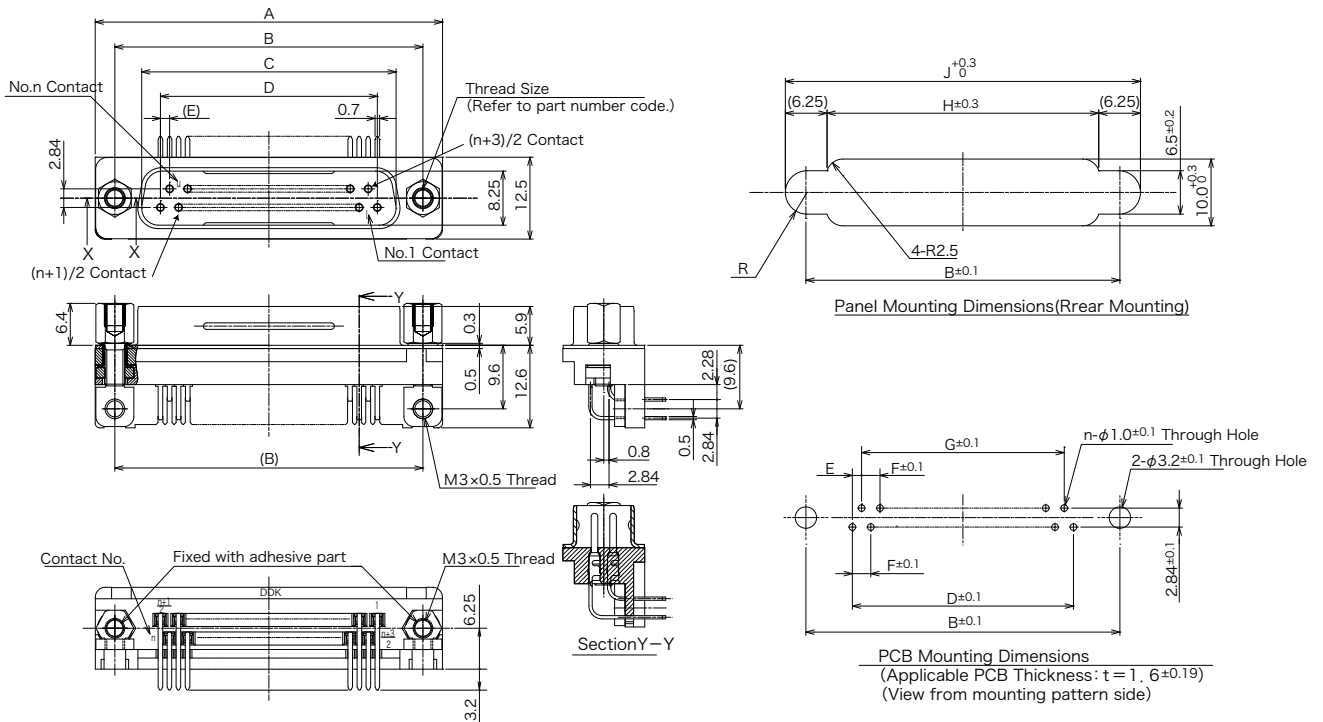

Number of Contact	A	B	C	D	E	F	G	H	J
9	30.80	24.99	16.80	10.98	1.37	2.74	8.22	18.50	31.00
15	39.10	33.32	25.12	19.20	1.37	2.74	16.44	26.80	39.30
25	53.00	47.04	38.84	33.12	1.38	2.76	30.36	40.70	53.20
37	69.30	63.50	55.30	49.68	1.38	2.76	46.92	57.00	69.50

© Specifications and/or dimensions in this catalogue are subject to change without notice.
Your catalogue checking the latest specifications with our drawings would be highly appreciated.

▶ Ground Tab

Ground Tab for 17LE

Ground tab enables 17LE series to ground to PCB easily.

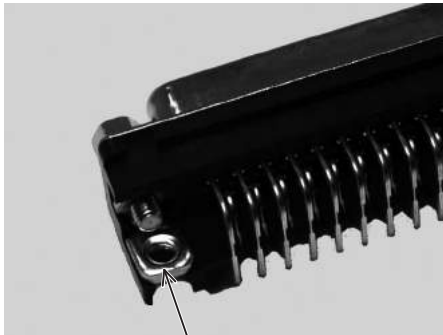

Thread M3x0.5

Ground Tab with Tapping Hole

Part Number : 17L-004B

Material / Finish: Steel / Ni Plating

※ Combination of stud 17L-002 □ is not available.

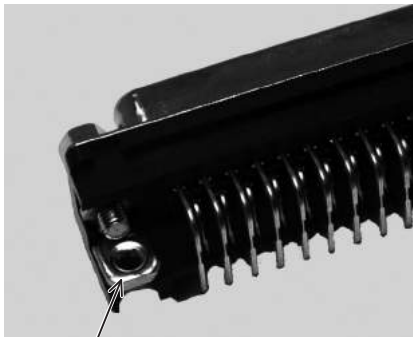

φ 3.2 Hole

Ground Tab with Through Hole

Part Number : 17L-004D

Material / Finish: Steel / Ni Plating

※ Combination of stud 17L-002 □ is not available.

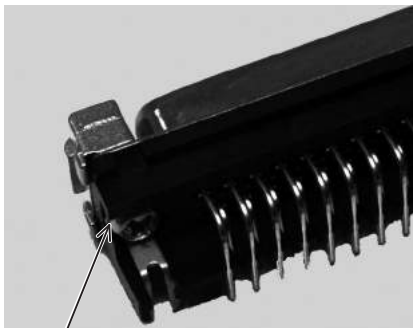

φ 3.6 Hole

Ground Tab with Board Lock

Part Number : 17L-004C-FA

Material / Finish: Copper Alloy / Sn-Ag Plating

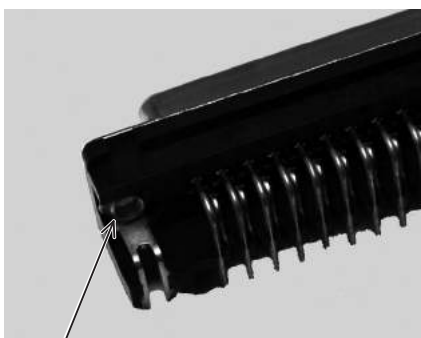

Thread M3x0.5

Ground Tab with Board Lock

Part Number : 17L-004E-FA

Material / Finish: Copper Alloy / Sn-Ag Plating

© Specifications and/or dimensions in this catalogue are subject to change without notice.
Your catalogue checking the latest specifications with our drawings would be highly appreciated.

▶ Mounting on Panel and PCB

(□ : Thread Size)

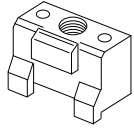

Stud (17L-002 □)

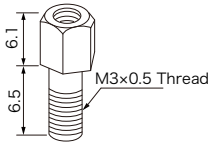
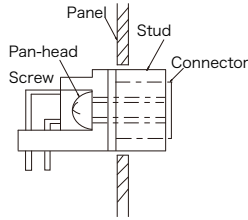

Jack Socket (17L-003 □ 1)

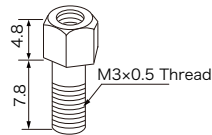
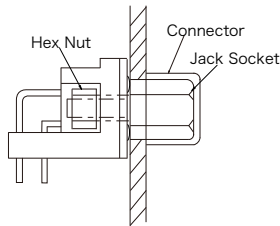

Jack Socket (17L-003 □ 3)

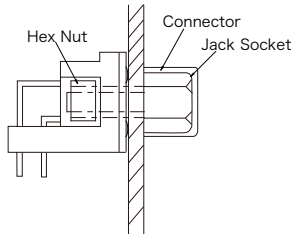

Panel Mounting Dimensions

Type 1

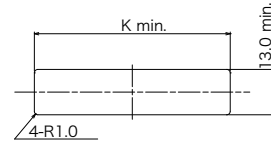

Type 2

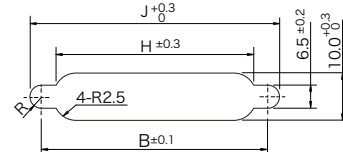

Type 3

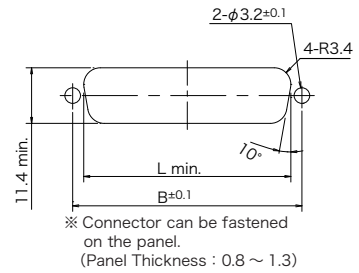

□ : Thread Size
 A : M2.6×0.45
 B : M3×0.5
 C : #4-40UNC

Number of Contact	B	H	J	K	L
9	24.99	18.50	31.0	34.09	20.50
15	33.32	26.80	39.3	42.42	28.80
25	47.04	40.70	53.2	56.14	42.50
37	63.50	57.00	69.5	72.60	59.10

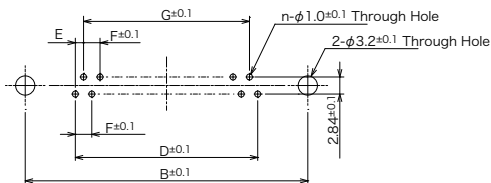
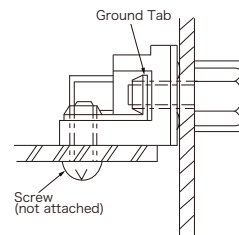
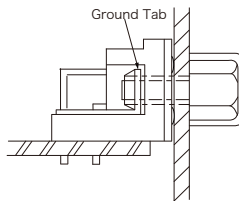
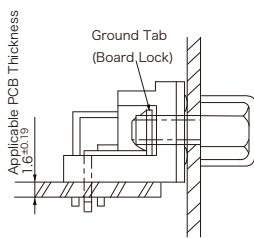

PCB Mounting Dimensions
 (Applicable PCB Thickness: t = 1.6±0.19)
 (View from mounting pattern side)

Number of Contact	B	D	E	F	G
9	24.99	10.98	1.37	2.74	8.22
15	33.32	19.20	1.37	2.74	16.44
25	47.04	33.12	1.38	2.76	30.36
37	63.50	49.68	1.38	2.76	46.92

© Specifications and/or dimensions in this catalogue are subject to change without notice.
 Your catalogue checking the latest specifications with our drawings would be highly appreciated.

▶ 17LE Series Mounting Accessories Deviation

※ ASSEMBLED: The mounting accessories are assembled with connector.

ATTACHED: The mounting accessories are attached separately.

		17LE-13 □ □ 0-27-FA 17LE-23 □ □ 0-27-FA				
Panel Mounting Operation	Ground Tab Part Number	None	17L-004B 	17L-004D 	17L-004C-FA 	17L-004E-FA
	Stud Jack Socket Part Number	None				
	None	17LE- □ 3 □ □ 0-27-FA				Press in ground tab 17L-004E-FA 17LE- □ 3 □ □ 0-27(D41)-FA
Type 1 Connector can not be fastened on the panel. 	17L-002 □ 	Stud 17L-002 □ and pan-head screw(L=6) are ASSEMBLED. 17LE- □ 3 □ □ 0-27(D2 □)-FA			Ground tab 17L-004C-FA is fastened by stud 17L-002 □ and pan-head screw (L=7). 17LE- □ 3 □ □ 0-27(D2 □ C)-FA	
Type 2 Connector can not be fastened on the panel. To prevent loosening, screws are locked by adhesive. 	17L-003 □ 1 	Jack socket 17L-003 □ 1 and hex nut(M3) are ASSEMBLED. 17LE- □ 3 □ □ 0-27(D3 □)-FA	Press in ground tab 17L-004B and jack socket 17L-003 □ 1 is ASSEMBLED. 17LE- □ 3 □ □ 0-27(D3 □ B)-FA	Press in ground tab 17L-004D and jack socket 17L-003 □ 1 is ASSEMBLED. 17LE- □ 3 □ □ 0-27(D3 □ D)-FA		Press in ground tab 17L-004E-FA and jack socket 17L-003 □ 1 is ASSEMBLED. 17LE- □ 3 □ □ 0-27(D3 □ H)-FA
Type 3 Connector can be fastened on the panel. Panel thickness: 1.3 max. 	17L-003 □ 3 	Jack socket 17L-003 □ 3 and hex nut(M3) are ASSEMBLED. 17LE- □ 3 □ □ 0-27(D4 □)-FA	Press in ground tab 17L-004B and jack socket 17L-003 □ 3 is ASSEMBLED. 17LE- □ 3 □ □ 0-27(D4 □ B)-FA	Press in ground tab 17L-004D and jack socket 17L-003 □ 3 is ASSEMBLED. 17LE- □ 3 □ □ 0-27(D4 □ D)-FA		Press in ground tab 17L-004E-FA and jack socket 17L-003 □ 3 is ASSEMBLED. 17LE- □ 3 □ □ 0-27(D4 □ K)-FA

Recommended

□ : Thread Size (Stud)
A : M2.6x0.45
B : M3x0.5
C : # 4-40UNC

※ Above list shows combinations of ground tab, stud and jack socket. The deviation is given in parenthesis in each sections. Slanting line means "not available". Regarding the detail, please contact our sales.

© Specifications and/or dimensions in this catalogue are subject to change without notice. Your catalogue checking the latest specifications with our drawings would be highly appreciated.