

E-Series Circuit Breaker

The E-Series hydraulic/magnetic circuit breaker is ideally suited for higher current and voltage applications. It is UL listed and CSA certified for branch circuit protection, which does not require a fuse back up. It is also UL recognized and CSA certified as a supplementary protector and as a manual motor controller.

Its physical features include front and back mounting, screw and stud terminals and heavy duty box wire connectors for solid wire or a pressure plate connector for standard wire. The E-series is available with handle actuators and can be configured as .1-125 amps, up to 600VAC or 125VDC, with choice of time delays, actuator colors and 1 to 6 poles configuration. Additionally, a Power Selector device is also available.

Product Highlights:

- ♦ UL listed and CSA certified
- ♦ Certified for circuit branch protection
- ♦ Recognized as a supplementary protector and as a manual motor controller
- ♦ Optional power selector device

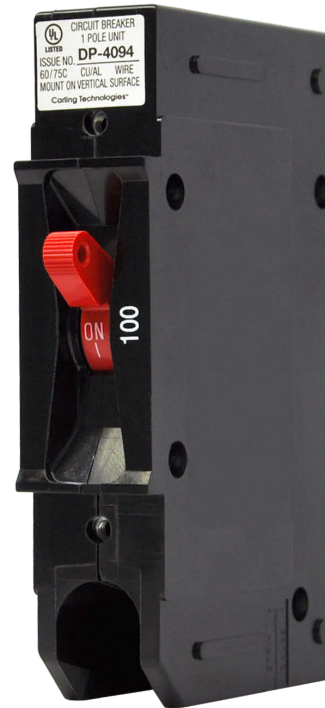

Typical Applications:

- ♦ Ideal for higher current and voltage applications
- ♦ Renewable energy systems
- ♦ Military
- ♦ Industrial controls
- ♦ Generators



Carling Technologies™

Innovative Designs. Powerful Solutions.

Carling Technologies, Inc.
60 Johnson Avenue • Plainville, CT 06062
Phone: (860) 793-9281 • Fax: (860) 793-9231
Email: sales@carlingtech.com • www.carlingtech.com

Electrical

Maximum Voltage	600VAC 50/60 Hz, 125VDC (See Table A)
Current Ratings	Standard current coils: 0.100, 0.250, 0.500, 1.00, 2.50, 5.00, 7.50, 10.0, 15.0, 20.0, 25.0, 30.0, 50.0, 60.0, 70.0 & 100 Amp.
Auxiliary Switch Rating	SPDT; 10.1A 250VAC, 1.0A 65VDC; 0.5A 80VDC, 0.1A 125VAC (with gold contacts).
Insulation Resistance	Minimum of 100 Megohms at 500 VDC.
Dielectric Strength	UL, CSA: 2200 V 50/60 Hz for one minute between all electrically isolated terminals. E-Series Circuit Breakers comply with the 8mm spacing and 3750V 50/60 Hz dielectric requirements from hazardous voltage to operator accessible surfaces, between adjacent poles and from main circuits to auxiliary circuits per Publications EN 60950 and VDE 0805.
Resistance, Impedance	Values from Line to Load Terminal - based on Series Trip Circuit Breaker.

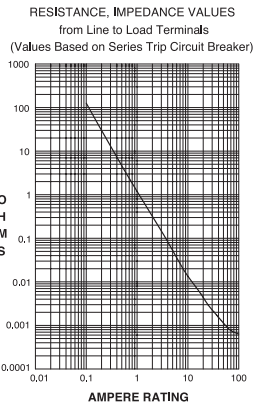

CURRENT (AMPS)	TOLERANCE (%)
0.10 - 5.0	± 15%
5.1 - 20.0	± 25%
20.1 - 125.0	± 35%

Pulse Tolerance Curves

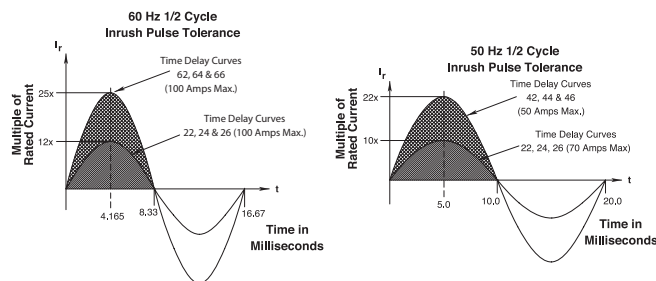

*Manufacturer reserves the right to change product specification without prior notice.

Mechanical

Endurance	10,000 ON-OFF operations @ 6 per minute; with rated Current and Voltage.
Trip Free	All E-Series Circuit Breakers will trip on overload, even when Handle is forcibly held in the ON position.
Trip Indication	The operating Handle moves positively to the OFF position when an overload causes the breaker to trip.

Physical

Number of Poles	1 - 6
Mounting	A 3" minimum spacing must be provided between the circuit breaker arc venting area on back connected E-Series circuit breakers and grounded obstructions. E-Series circuit breakers must be mounted on a vertical surface.
Connectors, Box Type	Front connected E-Series circuit breakers are supplied with box type pressure connectors that accept copper or aluminum conductors as follows: 1/0-14 Copper, 1/0-12 Aluminum.
Internal Circuit Configuration	Series and Switch Only, (with or without auxiliary switch). Shunt with current coils.
Weight	Approximately 252 grams/pole (Approximately 9 ounces/pole)
Standard Colors	Housing-Black; Actuator - See Ordering Scheme.

Environmental

Designed in accordance with requirements of specification MIL PRF-55629 & MIL-STD-202G as follows:	
Shock	Withstands 100 Gs, 6ms, sawtooth while carrying rated current per Method 213, Test Condition "I".
Vibration	Withstands 0.060" excursion from 10-55 Hz, and 10 Gs 55-500 Hz, at rated current per Method 204C, Test Condition A.
Moisture Resistance	Method 106D, i.e., ten 24-hour cycles @ + 25°C to +65°C, 80-98% RH.
Salt Spray	Method 101, Condition A (90-95% RH @ 5% NaCl Solution, 96 hrs).
Thermal Shock	Method 107D, Condition A (Five cycles @ -55°C to +25°C to +85°C to +25°C).
Operating Temperature	-40° C to +85° C

Agency Certifications

UL Recognized

UL Standard 1077



Component Recognition Program as Protectors, Supplementary (Guide QVNU2, File E75596)

Component Recognition Program as Manual Motor Controls (Guide NLRV2, File E135367)

UL Standard 1500



Protectors, Supplementary for Marine Electrical & Fuel Systems (Guide PEQZ2, File E75596)
Ignition Protection

UL Listed

UL Standard 489



Circuit Breakers, Molded Case (Guide DIVQ, File E129899)

CSA Accepted



Component Supplementary Protector (Class 3215 30, File 047848 0 000)
CSA Standard C22.2 No. 235

CSA Certified



Circuit Breaker Molded Case (Class 1432 01, File 093910),
CSA Standard C22.2 No. 5.1 - M

TUV Certified



EN60934 under License No. R72031056

VDE Certified



EN60934, VDE 0642 under File No. 10537

Electrical Tables

Table A: Lists UL Listed (489) & CSA Certified (C22.2 No. 5) configurations & performance capabilities as a Molded Case Circuit Breaker.

E SERIES TABLE A : UL489 LISTED BRANCH CIRCUIT BREAKERS						
CIRCUIT CONFIGURATION	VOLTAGE			CURRENT RATING FULL LOAD AMPS	INTERRUPTING CAPACITY (AMPS) WITHOUT BACKUP FUSE	HIGH INTERRUPTING CAPACITY (AMPS)
	MAX. RATING	FREQUENCY	PHASE			
SERIES	80	DC	---	0.10 - 100	5,000	50,000
	125	DC	---	0.10 - 100	5,000	10,000
	125	DC	---	0.10 - 125	10,000	---
	120	50 / 60	1	0.10 - 125	10,000	---
	240	50 / 60	1	0.10 - 30	5,000	10,000
	240	50 / 60	1	31 - 100	5,000	---
	120 / 240	50 / 60	1	0.10 - 30	5,000	10,000
	120 / 240	50 / 60	1	31 - 100	5,000	---
	120 / 240	50 / 60	1	101 - 125	10,000	---
	240	50 / 60	3	0.10 - 100	5,000	---

Table B: Lists UL Recognized & CSA Accepted configurations & performance capabilities as a Component Supplementary Protector.

E -SERIES TABLE B: COMPONENT SUPPLEMENTARY PROTECTORS									
CIRCUIT CONFIGURATION	VOLTAGE			CURRENT RATING		SHORT CIRCUIT CAPACITY (AMPS)		APPLICATION CODES	
	MAX. RATING	FREQUENCY	PHASE	FULL LOAD AMPS	GENERAL PURPOSE AMPS	UL/CSA		UL	CSA
						WITH BACKUP FUSE ³	WITHOUT BACKUP FUSE		
SERIES & SHUNT	125	DC	---	0.02 - 100	---	---	5,000	TC1,2, OL1, U1	TC1,2, OL1, U1
	125	DC	---	---	101 - 120	---	5,000	TC1,2, OL0, U1	TC1,2, OL0, U1
	150	DC	---	---	0.02 - 125	---	5,000	TC1, OL0, U3	TC1, OL0, U3
	160	DC	---	0.02 - 100	---	---	5,000	TC1,2, OL1, U1	TC1,2, OL1, U1
	150 / 300	DC	---	0.02 - 100	---	---	5,000	TC1,2, OL1, U1	TC1,2, OL1, U1
	120 / 240	50 / 60	1	---	0.02 - 100	---	5,000	TC1,2, OL0, U1	TC1,2, OL0, U1
	240	50 / 60	1	0.02 - 100	---	---	5,000	TC1,2, OL1, U1	TC1,2, OL1, U1
	250	50 / 60	1	0.02 - 100	---	10,000	---	TC1,2, OL1, C1	TC1,2, OL1, C1
	277	50 / 60	1	0.02 - 100	---	---	5,000	TC1,2, OL1, U1	TC1,2, OL1, U1
						10,000	---	TC1,2, OL1, C1	TC1,2, OL1, C1
	480	50 / 60	1 & 3	0.02 - 100	---	10,000	---	TC1,2, OL1, C1	TC1,2, OL1, C1
	480 ¹	50 / 60	1 & 3	0.02 - 50	---	10,000	---	TC1,2, OL1, C1	TC1,2, OL1, C1
	600	50 / 60	1 & 3	0.02 - 100	---	10,000	---	TC1,2, OL1, C1	TC1,2, OL1, C1
	600 ²	DC	---	---	0.02 - 125	---	5,000	TC1, OL0, U3	TC1, OL0, U3
SWITCH ONLY	125	DC	---	0.02 - 120	---	---	---	---	---
	160	DC	---	0.02 - 100	---	---	---	---	---
	240	50 / 60	1	0.02 - 100	---	---	---	---	---
	277	50 / 60	1	0.02 - 100	---	---	---	---	---
	480	50 / 60	1 & 3	0.02 - 100	---	---	---	---	---
600	50 / 60	1 & 3	0.02 - 100	---	---	---	---	---	

Table B Notes:
 1 Per pole opposite polarity rating - Delta Configuration.
 2 4 Poles connected in series
 3 Requires branch circuit backup with a UL Listed Type K5 or RK5 fuse rated 15A minimum and no more than 4 times full load amp rating and not to exceed 225A.

Electrical Tables

Table C: Lists UL Recognized, CSA Accepted and VDE Certified configurations and performance capabilities as a Component Supplementary Protector.

E -SERIES TABLE C: COMPONENT SUPPLEMENTARY PROTECTORS WITH VDE										
CIRCUIT CONFIGURATION	VOLTAGE			CURRENT RATING FULL LOAD AMPS	SHORT CIRCUIT CAPACITY (AMPS)			APPLICATION CODES		CONSTRUCTION NOTES
	MAX. RATING	FREQUENCY	PHASE		UL/CSA		VDE (Icn)	UL	CSA	
				WITH BACKUP FUSE ¹	WITHOUT BACKUP FUSE	WITHOUT BACKUP FUSE				
SERIES & SHUNT	125	DC	---	0.1 - 100	---	5,000	5,000	TC1,2, OL1, U1	TC1,2, OL1, U1	1 or 2 Poles
	240	50 / 60	1 & 3	0.1 - 100	---	5,000	5,000	TC1,2, OL1, U1	TC1,2, OL1, U1	1 - 5 Poles. Up to 4 Current Poles, 1 Voltage Pole
	415	50 / 60	1 & 3	0.1 - 100	10,000	---	4,000	TC1,2, OL1, C1	TC1,2, OL1, C1	2 - 5 Poles. Up to 4 Current Poles, 1 Voltage Pole
SWITCH ONLY	125	DC	---	0.1 - 125						
	240	50 / 60	1 & 3	0.1 - 100						
	415	50 / 60	1 & 3	0.1 - 100						

Table C Notes:

- ¹ Requires branch circuit backup with a UL LISTED Type K5 or RK5 fuse rated 15A minimum and no more than 4 times full load amp rating and not to exceed 225 amps.

Table D: Lists UL Recognized, CSA Accepted configurations and performance capabilities as Protectors, Supplementary for Marine Electrical and Fuel Systems (Guide PEQZ2, File E75596). Ignition Protected per UL 1500. UL Classified Small Craft Electrical Devices, Marine in accordance with ISO 8846 (Guide UZMK, File MQ1515) as Marine Supplementary Protectors.

E SERIES TABLE D : UL1500 (Marine Ignition Protection)							
CIRCUIT CONFIGURATION	VOLTAGE			CURRENT RATING FULL LOAD AMPS	SHORT CIRCUIT CAPACITY (AMPS) WITHOUT BACKUP FUSE	APPLICATION CODES	
	MAX. RATING	FREQUENCY	PHASE			UL	CSA
SERIES	65	DC	---	0.02 - 100	5,000	TC1,2,OL1,U1	TC1,2,OL1,U1
	125	50 / 60	1	0.02 - 100	1,500	TC1,2,OL1,U1	TC1,2,OL1,U1
	250	50 / 60	1	0.02 - 100	1,500	TC1,2,OL1,U1	TC1,2,OL1,U1

E A 2 - B 0 - 24 - 450 - 1 2 A - C B

1 Series 2 Actuator 3 Poles 4 Circuit 5 Auxiliary Switch 6 Frequency & Delay 7 Current Rating 8 Terminal 9 Actuator Color 10 Mounting/Barriers 11 Maximum Application Rating 12 Agency Approval

1 SERIES

E

2 ACTUATOR

A Handle, one per pole

3 POLES¹

1	One	3	Three	5	Five
2	Two	4	Four	6	Six

4 CIRCUIT²

A ³	Switch Only (no coil)	E	Shunt Trip (voltage)
B	Series Trip (current)	F	Relay Trip (current)
C	Series Trip (voltage)	G	Relay Trip (voltage)
D	Shunt Trip (current)		

5 AUXILIARY SWITCH⁴

0	without Auxiliary Switch	6	S.P.D.T. 0.110 Q.C. Terminals
2	S.P.D.T. 0.110 Q.C. Terminals	7	S.P.D.T. 0.110 Q.C. Terminals (Gold Contacts)
3	S.P.D.T. 0.139 Solder Lug	8	S.P.D.T. 0.187 Q.C. Terminals
4	S.P.D.T. 0.110 Q.C. Terminals (Gold Contacts)	9	S.P.D.T. 0.187 Q.C. Terminals

6 FREQUENCY & DELAY

03 ³	DC 50/60Hz, Switch Only	34	DC, 50/60Hz Medium
10 ⁵	DC Instantaneous	36	DC, 50/60Hz Long
12	DC Short	62	50/60Hz Short, Hi-Inrush
14	DC Medium	64	50/60Hz Medium, Hi-Inrush
16	DC Long	66	50/60Hz Long, Hi-Inrush
20 ⁵	50/60Hz Instantaneous	72	DC, Short, Hi-Inrush
22	50/60Hz Short	74	DC, Medium, Hi-Inrush
24	50/60Hz Medium	76	DC, Long, Hi-Inrush
26	50/60Hz Long	92 ⁶	DC, 50/60Hz Short, Hi-Inrush
30	DC, 50/60Hz Instantaneous	94 ⁶	DC, 50/60Hz Medium, Hi-Inrush
32	DC, 50/60Hz Short	96 ⁶	DC, 50/60Hz Long, Hi-Inrush

7 CURRENT RATING (AMPERES)⁷

CODE	AMPERES						
020	0.020	235	0.350	430	3.000	614	14.000
025	0.025	240	0.400	435	3.500	615	15.000
030	0.030	245	0.450	440	4.000	616	16.000
035	0.035	250	0.500	445	4.500	617	17.000
040	0.040	255	0.550	450	5.000	618	18.000
045	0.045	260	0.600	455	5.500	620	20.000
050	0.050	265	0.650	460	6.000	622	22.000
055	0.055	270	0.700	465	6.500	624	24.000
060	0.060	275	0.750	470	7.000	625	25.000
065	0.065	280	0.800	475	7.500	630	30.000
070	0.070	285	0.850	480	8.000	635	35.000
075	0.075	290	0.900	485	8.500	640	40.000
080	0.080	295	0.950	490	9.000	650	50.000
085	0.085	410	1.000	495	9.500	660	60.000
090	0.090	512	1.250	610	10.000	670	70.000
090	0.095	415	1.500	710	10.500	680	80.000
210	0.100	517	1.750	611	11.000	690	90.000
215	0.150	420	2.000	711	11.500	810	100.000
220	0.200	522	2.250	612	12.000	811	110.000
225	0.250	425	2.500	712	12.500	812	120.000
230	0.300	527	2.750	613	13.000	912 ⁸	125.000

OR VOLTAGE COIL (MIN. TRIP RATING, VOLTS)⁵

A06	6 DC, 5 DC	A65	65 DC, 55 DC	J48	48 AC, 40 AC
A12	12 DC, 10 DC	B25	125 DC, 100 DC	J65	65 AC, 55 AC
A18	18 DC, 15 DC	J06	6 AC, 5 AC	K20	120 AC, 65 AC
A24	24 DC, 20 DC	J12	12 AC, 10 AC	L40	240 AC, 130 AC
A32	32 DC, 25 DC	J18	18 AC, 15 AC		
A48	48 DC, 40 DC	J24	24 AC, 20 AC		

Notes:

- VDE approval on 1-5 poles only. Standard multi-pole units identical poles except when specifying auxiliary switch - (see Note 4). For mixed ratings, consult factory.
- Switch Only & Series Trip construction available w/either front or back connected terminals. Shunt construction available w/back connected terminals. (Terminal Codes 1 & 2) only. Circuit Codes B,C & D are VDE approved.
- Switch Only construction: 30 amps or less select Current Rating Code 630; 31-70 amps, select Current Rating code 670; 71-100 amps, select Current Rating Code 810; 101-125 amps Select Current Rating Code 912. Switch Only is VDE approved only if tied to a protected pole.

8 TERMINAL¹²

BACK CONNECTED (FRONT MOUNTED ONLY)		MAX. RATING
1 ⁹	10-32 Stud (All Terminals)	50 A
2 ⁹	1/4-20 Stud (All Terminals)	120 A
A ⁹	M5 Stud (Line & Load)	50 A
B ⁹	M6 Stud (Line & Load)	100 A
FRONT CONNECTED (BACK MOUNTED ONLY)		MAX. RATING
3 ¹⁰	Box Wire Connector (Line & Load)	100 A
C ¹¹	Box Wire Connector w/ Pressure Plate (Line & Load)	100 A
4	10-32 Screw (Line & Load)	50 A
D	M5 Screw (Line & Load)	50 A
5	10-32 "Bus-Type" Screw (Line), 10-32 Screw (Load)	50 A
E	M5 "Bus-Type" Screw (Line), 10-32 Screw (Load)	50 A
6 ¹⁰	10-32 "Bus-Type" Screw (Line), Box Wire Connector (Load)	100 A
F ¹¹	10-32 "Bus-Type" Screw (Line), Box Wire Connector w/ Pressure Plate (Load)	100 A
7	1/4-20 Screw (Line & Load)	100 A
G	M6 Screw (Line & Load)	100 A
8	1/4-20 "Bus-Type" Screw (Line), 1/4-20 Screw (Load)	100 A
H	M6 "Bus-Type" Screw (Line), M6 Screw (Load)	100 A
9 ¹⁰	1/4-20 "Bus-Type" Screw (Line), Box Wire Connector (Load)	100 A
J ¹¹	1/4-20 "Bus-Type" Screw (Line), Box Wire Connector w/ Pressure Plate (Load)	100 A

9 ACTUATOR COLOR & LEGEND¹³

Actuator Color	I-O	ON-OFF	Dual	Legend Color
White	A	B	1	Black
Black	C	D	2	White
Red	F	G	3	White
Green	H	J	4	White
Blue	K	L	5	White
Yellow	M	N	6	Black
Gray	P	Q	7	Black
Orange	R	S	8	Black

10 MOUNTING/BARRIERS

BACK CONNECTED (FRONT MOUNTED ONLY)

Mounting Inserts

A 6-32
B ISO M3

FRONT CONNECTED (BACK MOUNTED ONLY)¹⁴

Back Mounting Foot Type **Front Mounting Inserts (Optional Use)**

C Short 6-32
D Short ISO M3
E Long 6-32
F Long ISO M3

11 MAXIMUM APPLICATION RATING¹⁵

A	65 VDC, 120 A	H ¹⁶	600 VAC, 100 A
B	125 VDC, 120 A	G ¹⁶	480 VAC, 100 A
C	120/240 VAC, 100 A	J ¹⁶	415 VAC, 100 A
D	240 VAC, 100 A	L ¹⁶	160 VDC, 100 A
E ¹⁶	277/480 VAC, 100 A	T	125 VDC/240 VAC, 100 A
F	277 VAC, 100 A	W ¹⁶	125 VDC/415 VAC, 100 A

12 AGENCY APPROVAL

B UL 1077 / UL508 Recognized & CSA Accepted
D UL 1077 Recognized, CSA Accepted, & VDE Certified

- Auxiliary Switch available on Switch Only and Series Trip units. On multi-pole units, only one auxiliary switch is normally supplied mounted in the extreme right pole. Back mounted units require special mounting provisions when auxiliary switch is specified. VDE approval on Auxiliary Switch Codes 0,2,3 & 4 only.
- Voltage Trip Coils are not rated for continuous duty. Available only with Frequency & Delay Codes 10 & 20. Series Trip construction with a voltage coil s VDE approved only if tied to a protected pole.
- Frequency & Delay Codes 92,94 & 96 are not VDE Certified.
- Current Coil Ratings 0.100 - 100 amps are VDE Certified.
- 125 A rating (Code 912) available as a Switch Only (Circuit Code A), rated 125 VDC (Code B).
- An Anti-Flash Over Barrier is supplied between poles on multi-pole units with 10-32 (Terminal Code 1), 1/4-20 (Code 2), M5 (Code A), and M6 (Code B) terminals per UL requirement.
- Box Wire Connector will accept #14 through 0 AWG. copper wire or #12 through 0 AWG. aluminum wire.
- Box Wire Connector with Pressure Plate for stranded wire, consult factory for details.
- Terminal Codes A,B,D,E,G & H are not VDE Certified.
- VDE approvals require Dual (I-O, ON-OFF) or I-O markings on all handles.
- Back Mounted breakers can also be front mounted by utilizing the proper front panel mounting inserts normally supplied. However, terminal connections must be made prior to mounting.
- Application ratings B,D,J,T & W are available with VDE.
- 415, 480 & 600 VAC ratings require 3 or 4 pole break 3Ø and 2 pole break 1Ø.

E A 2 - B 0 - 24 - 450 - 1 2 A - C C

1 Series
2 Actuator
3 Poles
4 Circuit
5 Auxiliary Switch
6 Frequency & Delay
7 Current Rating
8 Terminal
9 Actuator Color
10 Mounting/ Barriers
11 Maximum Application Rating
12 Agency Approval

1 SERIES
E

2 ACTUATOR
A Handle, one per pole

3 POLES*

1	One	3	Three	5	Five
2	Two	4	Four	6	Six

4 CIRCUIT*

B Series Trip (current)	C³	Series Trip (voltage)
--------------------------------	----------------------	-----------------------

5 AUXILIARY SWITCH*

0	without Auxiliary Switch	6	S.P.D.T. 0.110 Q.C. Terminals
2	S.P.D.T. 0.110 Q.C. Terminals	7	S.P.D.T. 0.110 Q.C. Terminals (Gold Contacts)
3	S.P.D.T. 0.139 Solder Lug	8	S.P.D.T. 0.187 Q.C. Terminals (Gold Contacts)
4	S.P.D.T. 0.110 Q.C. Terminals (Gold Contacts)	9	S.P.D.T. 0.187 Q.C. Terminals

6 FREQUENCY & DELAY

10 ⁵	DC Instantaneous	36	DC, 50/60Hz Long
12	DC Short	62	50/60Hz Short, Hi-Inrush
14	DC Medium	64	50/60Hz Medium, Hi-Inrush
16	DC Long	66	50/60Hz Long, Hi-Inrush
20 ⁵	50/60Hz Instantaneous	72	DC, Short, Hi-Inrush
22	50/60Hz Short	74	DC, Medium, Hi-Inrush
24	50/60Hz Medium	76	DC, Long, Hi-Inrush
26	50/60Hz Long	92 ⁶	DC, 50/60Hz Short, Hi-Inrush
30	DC, 50/60Hz Instantaneous	94 ⁶	DC, 50/60Hz Medium, Hi-Inrush
32	DC, 50/60Hz Short	96 ⁶	DC, 50/60Hz Long, Hi-Inrush
34	DC, 50/60Hz Medium		

7 CURRENT RATING (AMPERES)*

CODE	AMPERES						
020	0.020	235	0.350	430	3.000	614	14.000
025	0.025	240	0.400	435	3.500	615	15.000
030	0.030	245	0.450	440	4.000	616	16.000
035	0.035	250	0.500	445	4.500	617	17.000
040	0.040	255	0.550	450	5.000	618	18.000
045	0.045	260	0.600	455	5.500	620	20.000
050	0.050	265	0.650	460	6.000	622	22.000
055	0.055	270	0.700	465	6.500	624	24.000
060	0.060	275	0.750	470	7.000	625	25.000
065	0.065	280	0.800	475	7.500	630	30.000
070	0.070	285	0.850	480	8.000	635	35.000
075	0.075	290	0.900	485	8.500	640	40.000
080	0.080	295	0.950	490	9.000	650	50.000
085	0.085	410	1.000	495	9.500	660	60.000
090	0.090	512	1.250	610	10.000	670	70.000
090	0.095	415	1.500	710	10.500	680	80.000
210	0.100	517	1.750	611	11.000	690	90.000
215	0.150	420	2.000	711	11.500	810	100.000
220	0.200	522	2.250	612	12.000	811	110.000
225	0.250	425	2.500	712	12.500	812	120.000
230	0.300	527	2.750	613	13.000	912⁸	125.000

OR VOLTAGE COIL (MIN. TRIP RATING, VOLTS)*

A06	6 DC, 5 DC	A65	65 DC, 55 DC	J48	48 AC, 40 AC
A12	12 DC, 10 DC	B25	125 DC, 100 DC	J65	65 AC, 55 AC
A18	18 DC, 15 DC	J06	6 AC, 5 AC	K20	120 AC, 65 AC
A24	24 DC, 20 DC	J12	12 AC, 10 AC	L40	240 AC, 130 AC
A32	32 DC, 25 DC	J18	18 AC, 15 AC		
A48	48 DC, 40 DC	J24	24 AC, 20 AC		

8 TERMINAL⁷

BACK CONNECTED (FRONT MOUNTED ONLY)

1⁸	10-32 Stud (All Terminals)	MAX. RATING	50 A
2⁸	1/4-20 Stud (All Terminals)		125 A

FRONT CONNECTED (BACK MOUNTED ONLY)

3⁹	Box Wire Connector (Line & Load)	MAX. RATING	100 A
C¹⁰	Box Wire Connector w/ Pressure Plate (Line & Load)		100 A
4	10-32 Screw (Line & Load)		50 A
5	10-32 "Bus-Type" Screw (Line), 10-32 Screw (Load)		50 A
6⁹	10-32 "Bus-Type" Screw (Line), Box Wire Connector (Load)		100 A
F¹⁰	10-32 "Bus-Type" Screw (Line), Box Wire Connector w/ Pressure Plate (Load)		100 A
7	1/4-20 Screw (Line & Load)		125 A
8	1/4-20 "Bus-Type" Screw (Line), 1/4-20 Screw (Load)		100 A
9⁹	1/4-20 "Bus-Type" Screw (Line), Box Wire Connector (Load)		100 A
J¹⁰	1/4-20 "Bus-Type" Screw (Line), Box Wire Connector w/ Pressure Plate (Load)		100 A

9 ACTUATOR COLOR & LEGEND¹²

Actuator Color	ON-OFF	Dual	Legend Color
White	B	1	Black
Black	D	2	White
Red	G	3	White
Green	J	4	White
Blue	L	5	White
Yellow	N	6	Black
Gray	Q	7	Black
Orange	S	8	Black

10 MOUNTING/BARRIERS

BACK CONNECTED (FRONT MOUNTED ONLY)

Mounting Inserts

A	6-32
B	ISO M3

FRONT CONNECTED (BACK MOUNTED ONLY)¹¹

Back Mounting Foot Type	Front Mounting Inserts (Optional Use)
C	Short 6-32
D	Short ISO M3
E	Long 6-32
F	Long ISO M3

11 MAXIMUM APPLICATION RATING

1	120 VAC
B	125 VDC, 120 A
C¹³	120/240 VAC, 100 A
D	240 VAC, 100 A

12 AGENCY APPROVAL

C	UL 489 Listed & CSA Certified
F	UL 489 Listed, CSA Certified, & VDE Certified

Notes:

- 1 Standard multi-pole units identical poles except when specifying auxiliary switch - (see Note 4). For mixed ratings, consult factory. VDE Certification on 1-5 poles only.
- 2 Series Trip construction available w/either front or back connected terminals.
- 3 Series Trip construction with a voltage coil is not available as a single pole unit and must be tied to a protected pole.
- 4 On multi-pole units, only one auxiliary switch is normally supplied mounted in the extreme right pole per Figure A. Back mounted units require special mounting provisions when auxiliary switch is specified. VDE Certification on auxiliary switch codes 0, 2, 3 & 4 only.
- 5 Voltage Trip Coils are not rated for continuous duty. Available only with Frequency & Delay Codes 10 & 20.
- 6 Frequency & Delay Codes 92, 94 & 96 are not VDE Certified.
- 7 Current Ratings under 0.100 amps are not VDE Certified .
- 8 An Anti-Flash Over Barrier is supplied between poles on multi-pole units with 10-32 Stud (Terminal Code 1) or 1/4-20 Stud (Code 2) terminals per UL requirement.
- 9 Box Wire Connector will accept #14 through 0 AWG. copper wire or #12 through 0 AWG. aluminum wire.
- 10 Box Wire Connector with Pressure Plate for stranded wire, consult factory for details.
- 11 Back Mounted breakers can also be front mounted by utilizing the proper front panel mounting inserts normally supplied. However, terminal connections must be made prior to mounting.
- 12 VDE Certification requires dual (I-O , ON-OFF) markings on all handles.
- 13 Not available with VDE Certification.

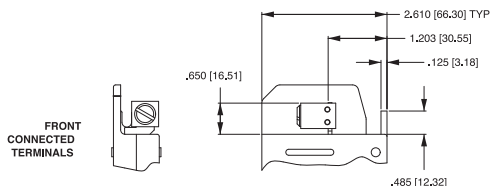
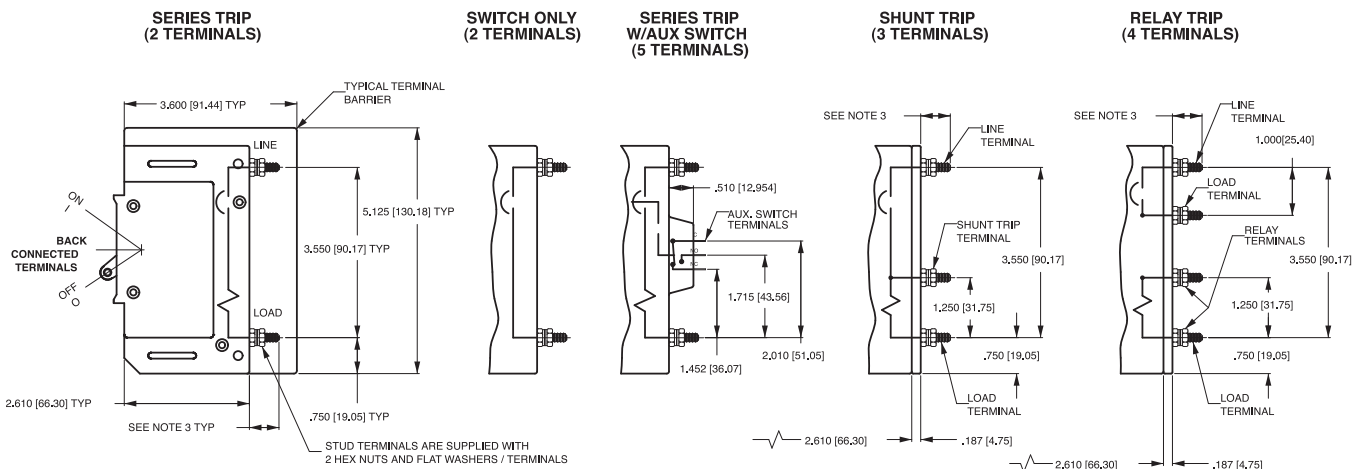

BOX TYPE WIRE CONNECTORS

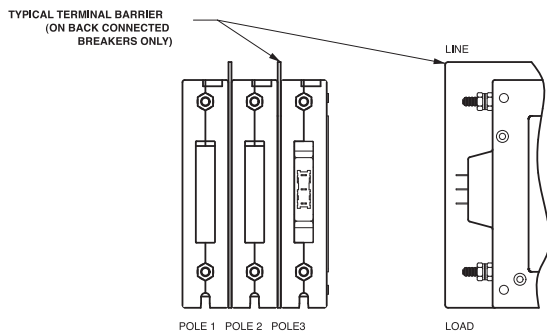
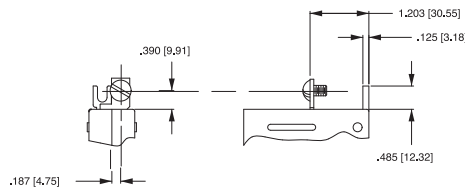

MULTI-POLE IDENTIFICATION SCHEME

AUXILIARY SWITCH TERMINALS

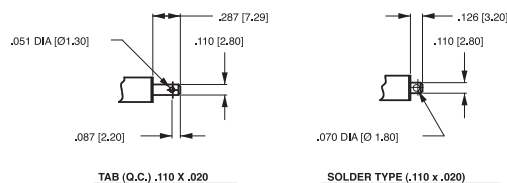
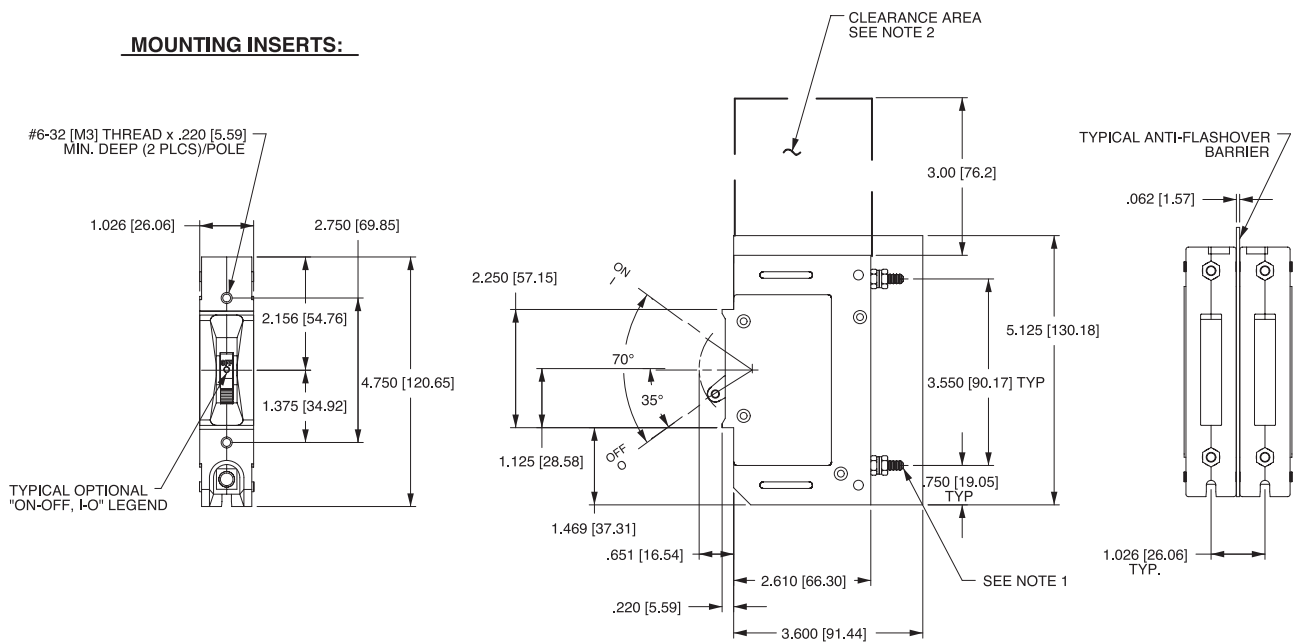

TABLE A TIGHTENING TORQUE SPECIFICATIONS		
THREAD SIZE TERMINAL TYPE	WIRE SIZE	TORQUE
#6-32 (M3) HARDWARE	—	7-8 IN-LBS (0.8-1.0 NM)
#10-32 THD TERMINAL SCREW	ALL	15-20 IN-LBS (1.5-2.0 NM)
1/4-20 THD TERMINAL SCREW	ALL	30-35 IN-LBS (3.4-4.0 NM)
#10-32 STUDS	ALL	15-20 IN-LBS (1.5-2.0 NM)
1/4-20 STUDS	ALL	30-35 IN-LBS (3.4-4.0 NM)
BOX WIRE CONNECTOR	14-10 AWG	35 IN-LBS (4.0 NM)
	8 AWG	40 IN-LBS (4.5 NM)
	6-4 AWG	45 IN-LBS (5.1 NM)
	50 AWG	50 IN-LBS (5.7 NM)
	3-10 AWG	50 IN-LBS (5.7 NM)

- Notes:
- All dimensions are in inches [millimeters].
 - Tolerance ± 0.020 [.51] unless otherwise specified.
 - 0-50 amps: 10-32 & M5 Studs .625 \pm 0.062/15.88 \pm 1.574 long.
 - 51-120 amps: 1/4-20 & M6 Studs .750 \pm 0.062/19.05 \pm 1.574 long.

MOUNTING INSERTS:



PANEL CUTOUT DETAIL

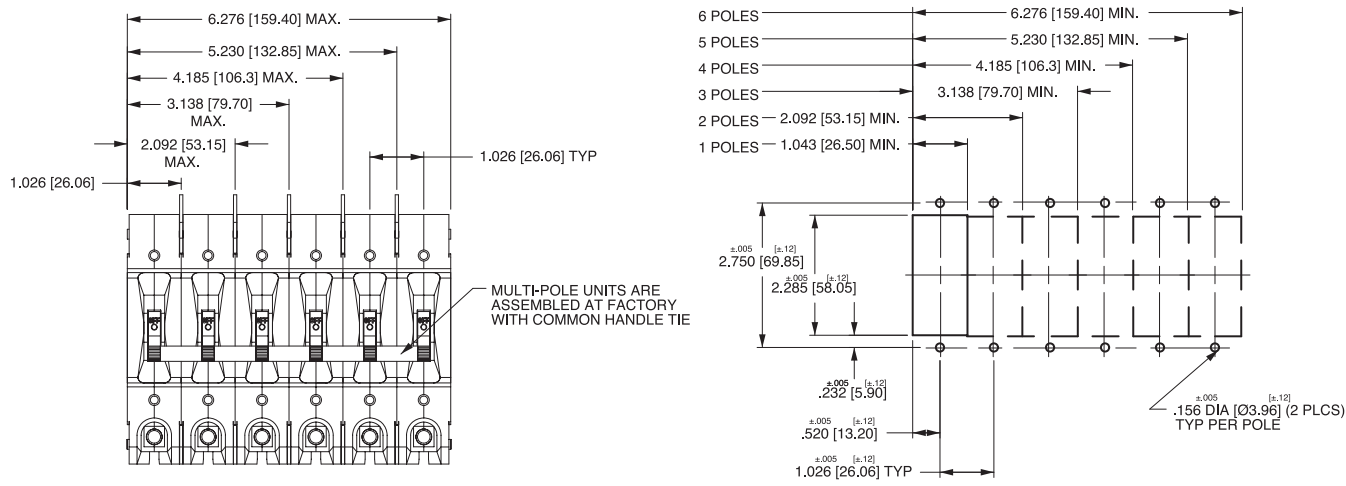

- Notes:
- 1 1/4 -20 stud terminal in Series Trip circuit configuration shown.
 - 2 A 3" min spacing must be provided between the circuit breaker arc venting area of back connected E-Series circuit breaker and grounded obstructions.
 - 3 All dimensions are in inches [millimeters].
 - 4 Tolerance ± 0.020 [.51] unless otherwise specified.
 - 5 Circuit breakers must be mounted on vertical surface.

MOUNTING INSERTS:

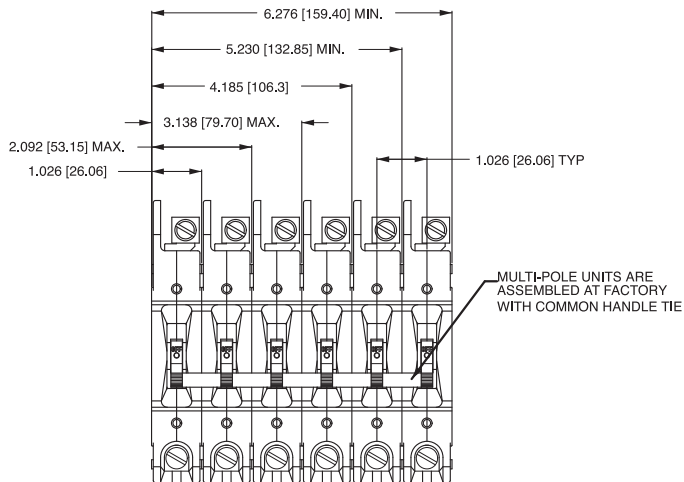
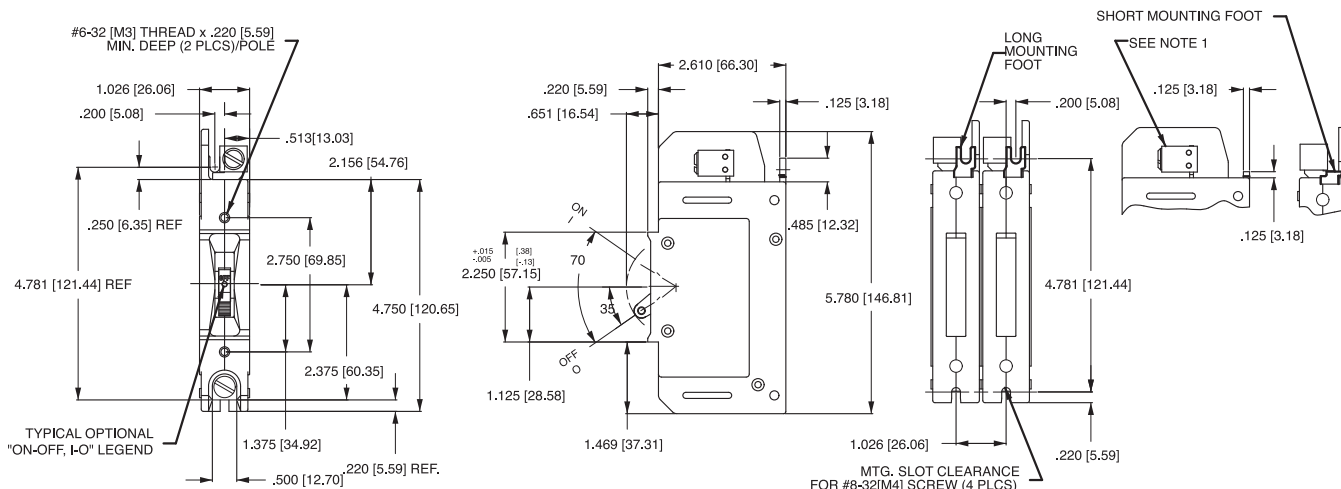

PANEL CUTOUT DETAIL

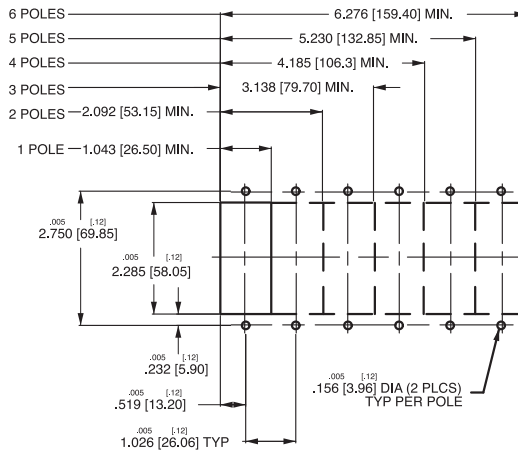

- Notes:
- 1 All dimensions are in inches [millimeters].
 - 2 Tolerance $\pm .020$ [51] unless otherwise specified.
 - 3 Box wire connector terminal in Series Trip circuit configuration shown.
 - 4 Circuit breakers must be mounted on vertical surface.