

Crydom

See full Datasheet below...

onlinecomponents.com
THE ONLINE DISTRIBUTOR OF ELECTRONIC COMPONENTS

BUY NOW

 **MASTER**TM
E L E C T R O N I C S

BUY NOW

masterelectronics.com & onlinecomponents.com
are **authorized** e-commerce distributors
of electronic components.

MCTC Series



- Microprocessor based temperature controller / SSR
- Ratings from 25A to 90A @ 48-530 VAC
- Direct J or K thermocouple input
- Voltage or current controlled setpoint
- Separate output enable / disable control
- Open thermocouple protection
- LED status indicators
- Optional 5Vdc output voltage for setpoint voltage Reference
- For use with resistive loads only

PRODUCT SELECTION

| Description | 25 A | 50 A | 90 A |
|-------------|----------|----------|----------|
| 280 VAC | MCTC2425 | MCTC2450 | MCTC2490 |
| 480 VAC | MCTC4825 | MCTC4850 | MCTC4890 |

AVAILABLE OPTIONS

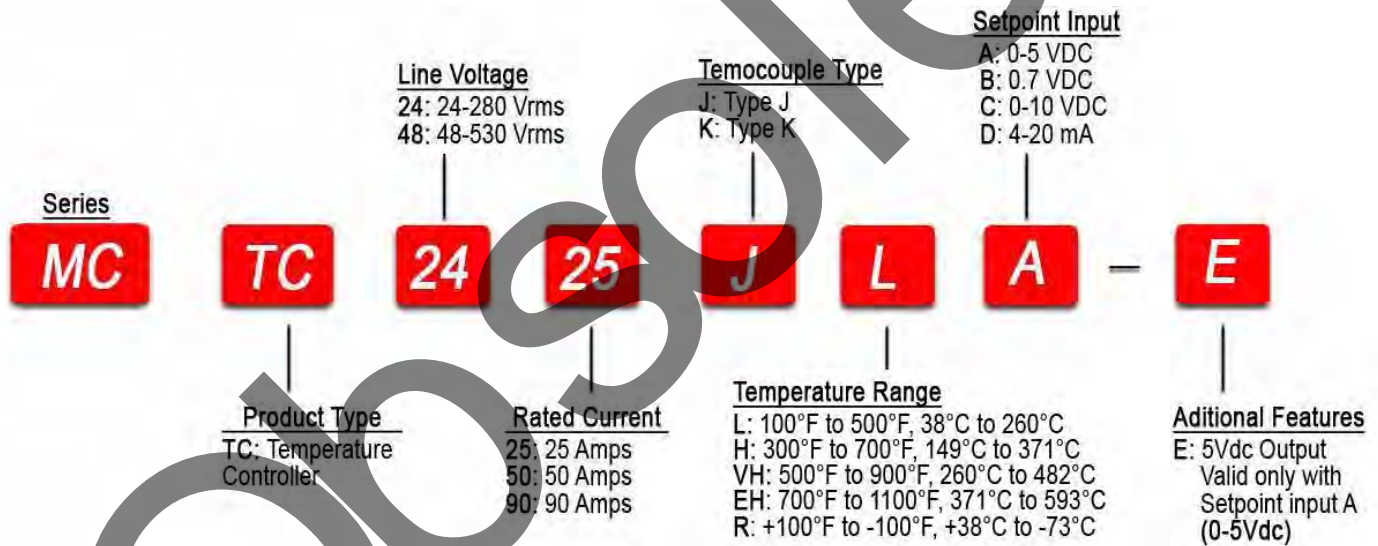

OUTPUT SPECIFICATIONS (voltage)

| Description | 240 VAC | 480 VAC |
|---|---------|---------|
| Operating Voltage (47-63Hz) [Vrms] | 24-280 | 48-530 |
| Transient Overvoltage [Vpk] | 600 | 1200 |
| Maximum Off-State Leakage Current @ Rated Voltage [mArms] | 7 | 12 |
| Minimum Off-State dv/dt @ Maximum Rated Voltage [V/μsec] | 200 | 200 |

OUTPUT SPECIFICATIONS (current)

| Description | 25 A | 50 A | 90 A |
|---|------|------|------|
| Maximum Load Current [Arms] | 25 | 50 | 90 |
| Minimum Load Current [mArms] | 150 | 150 | 150 |
| Maximum Surge Current (16.6ms) [Apk] | 250 | 625 | 1200 |
| Maximum On-State Voltage Drop @ Rated Current [Vpk] | 1.6 | 1.6 | 1.6 |
| Thermal Resistance Junction to Case (Rjc) [°C/W] | 1.02 | 0.63 | 0.28 |
| Maximum I ² t for Fusing (8.3 msec) [A ² sec] | 260 | 1620 | 6000 |
| Minimum Power Factor (with Maximum Load) | 0.5 | 0.5 | 0.5 |

INPUT SPECIFICATIONS (1)

| Description | DC Control |
|--|------------|
| P1 Voltage Supply Range (VDC) | 8-32 |
| P1 Supply Current Range [mA] (2) | 28-30 |
| Control Nominal Input Impedance [Ohms] [P3] | 30K |
| Control Must Operate Voltage "On" [VDC] [P3] | 5-32 |
| Control Must Release Voltage "Off" [VDC] [P3] | 0-4 |
| Control Input Current [mA] [P3] | 0-1.25 |
| PLVI Range Option A [VDC] [P4] (3) | 0.8-5 |
| PLVI Range Option B [VDC] [P4] (3) | 1-7 |
| PLVI Range Option C [VDC] [P4] (3) | 2-10 |
| PLVI Range Option D [ma] [P4] (3) | 4-20 |
| Nominal Input Impedance Option A,B,C [ohms] [P4] | 20K |
| Nominal Input Impedance Option D [ohms] [P4] | 220 |
| Output Voltage [VDC] [P5] | 4.75-5.25 |
| Maximum Output Current [mA] [P5] | 10 |

GENERAL SPECIFICATIONS

| Description | Parameters |
|--|---|
| Dielectric Strength, Input/Output/Base (50/60Hz) | 4000 Vrms |
| Minimum Insulation Resistance (@ 500 V DC) | 10 ⁹ Ohm |
| Maximum Capacitance, Input/Output | 10 pF |
| Ambient Operating Temperature Range | -20 to 80°C |
| Ambient Storage Temperature Range | -40 to 125 °C |
| Weight (typical) | 3.0 oz (86.5g) |
| Encapsulation | Thermally conductive Epoxy |
| Terminals-Power | Screws and Saddle Clamps Furnished, Unmounted |
| Terminals-Control | Barrier Strip Screw Terminals |
| Recommended Terminal Screw Torque Range: | 8-32 Screws -20 in. lbs. (Screws dry without grase) |

OUTPUT STATUS FUNCTIONS

| Description | GREEN LED (setpoint) | RED LED (output) |
|--------------------------------------|-------------------------|-------------------|
| Initial Logic Supply On | Flash Once | Flash Once |
| Operating (to 85 % of set point) | Off | On |
| Approaching Setpoint | Off | Variable Flashing |
| At Setpoint (± 5%) | On | Slow Flashing |
| Over Setpoint (>5%) (4) | Flashing | Off |
| Short-Cycle Timing ("R" suffix only) | Flash 2x Intermittently | Off |
| Open Thermocouple | Flash 3x Intermittently | Off |

GENERAL NOTES

- 1) Voltages are reference to GND (Ground = 0 VDC) P2
- 2) Input current may vary with -E option.
- 3) PLVI voltage can go up to max. supply voltage without damage.
- 4) Below Setpoint for "R" suffix

MECHANICAL SPECIFICATIONS

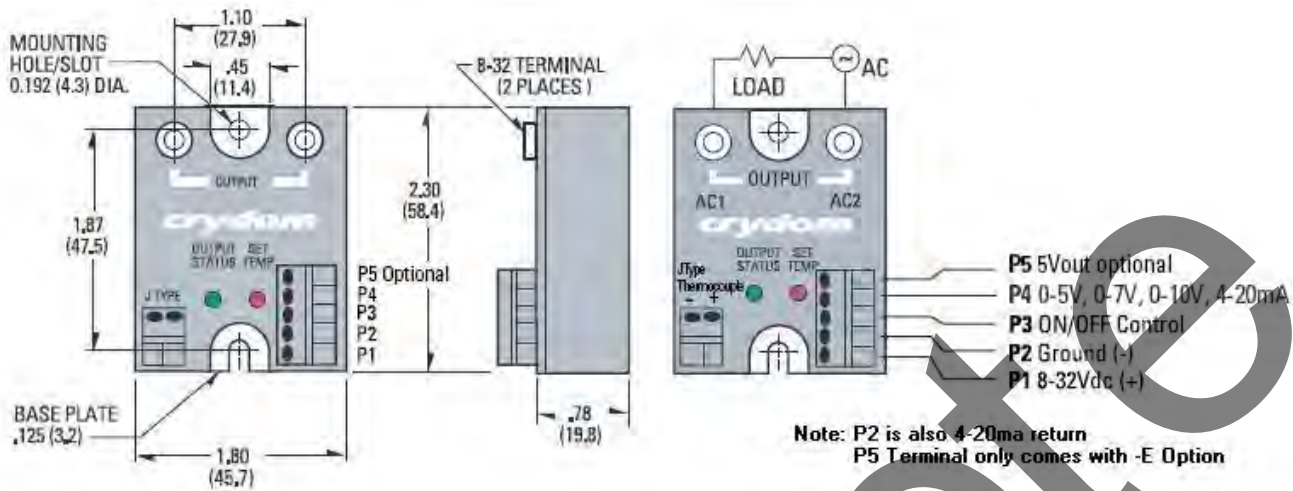

WIRING DIAGRAM

Wiring Example

(for Options A, B or C using an external potentiometer)

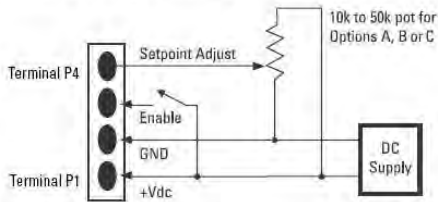

Wiring Example Option -E

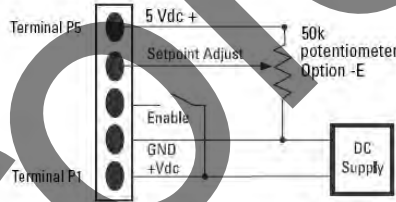

THERMAL DERATE INFORMATION

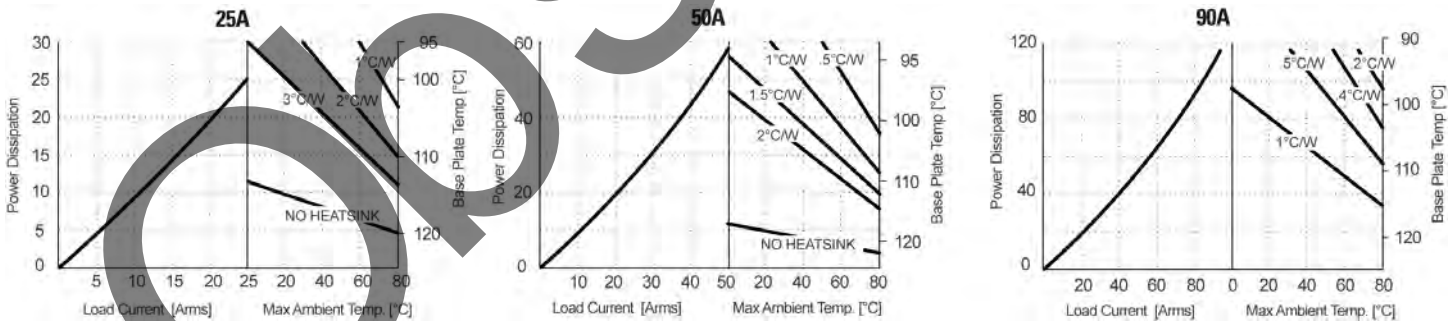

TEMPERATURE VS SETPOINT INPUT P4

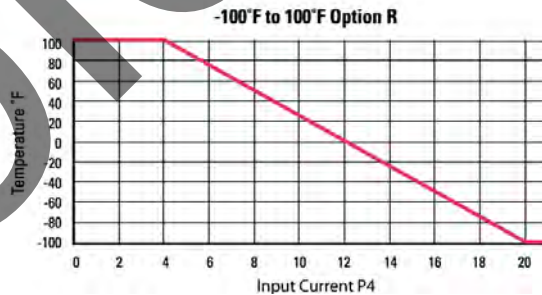
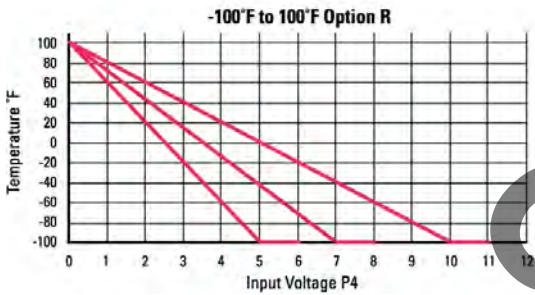
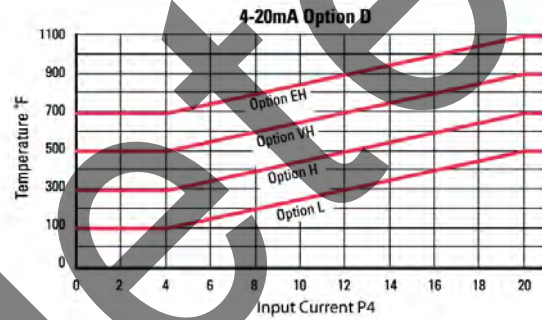
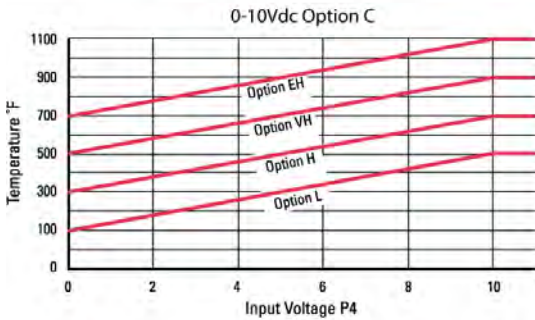
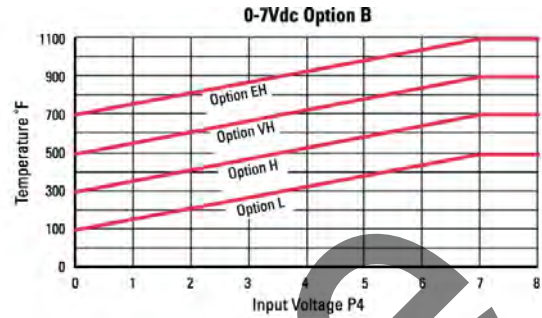
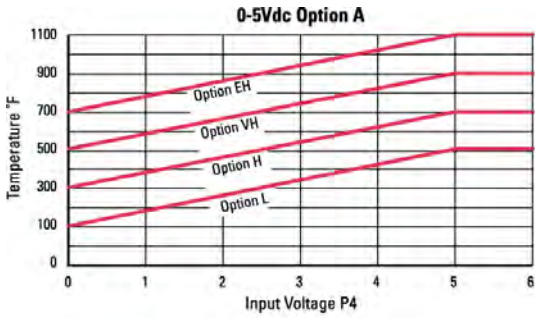

AGENCY APPROVALS

UL E116949



Rev. 032111

|  WARNING / AVERTISSEMENT / WARNUNG / ADVERTENCIA / AVVERTENZA / AVISO | | |
|--|--|---|
| RISK OF MATERIAL DAMAGE AND HOT ENCLOSURE <ul style="list-style-type: none"> The product's side panels may be hot, allow the product to cool before touching. Follow proper mounting instructions including torque values. Do not allow liquids or foreign objects to enter this product. <p>Failure to follow these instructions can result in serious injury, or equipment damage.</p> | RISQUE DE DOMMAGE MATERIEL ET DE SURCHAUFFE DU BOITIER <ul style="list-style-type: none"> Les panneaux latéraux du produit peuvent être chauds. Laisser le produit refroidir avant de le toucher. Respecter les consignes de montage, et notamment les couples de serrage. Ne pas laisser pénétrer de liquide ni de corps étrangers à l'intérieur du produit. <p>Le non-respect de cette directive peut entraîner, des lésions corporelles graves ou des dommages matériels.</p> | GEFAHR VON MATERIALSCHÄDEN UND GEHÄUSEERHITZUNG <ul style="list-style-type: none"> Die Seitenwände können heiß sein. Lassen Sie das Produkt abkühlen, bevor Sie es berühren. Beachten Sie die Montageanweisungen. Führen Sie keine Flüssigkeiten oder Fremdkörper in das Produkt ein. <p>Die Nichtbeachtung dieser Anweisung kann Körperverletzung oder Materialschäden zur Folge haben.</p> |
| RIESGO DE DAÑOS MATERIALES Y DE SOBRECALENTAMIENTO DE LA UNIDAD <ul style="list-style-type: none"> Los paneles laterales del producto pueden estar calientes. Esperar que el producto se enfríe antes de tocarlo. Respetar las instrucciones de montaje, y en particular los pares de apretado. No dejar que penetren líquidos o cuerpos extraños en el producto. <p>Si no se respetan estas precauciones pueden producirse graves lesiones, daños materiales.</p> | RISCHIO DI DANNI MATERIALI E D'INVOLUCRO CALDO <ul style="list-style-type: none"> I pannelli laterali dell'apparecchio possono scottare; lasciar quindi raffreddare il prodotto prima di toccarlo. Seguire le istruzioni di montaggio corrette. Non far entrare liquidi o oggetti estranei in questo apparecchio. <p>La mancata osservanza di questa precauzione può causare gravi rischi per l'incolumità personale o danni alle apparecchiature.</p> | RISCO DE DANO MATERIAL E DE AQUECIMENTO <ul style="list-style-type: none"> Os painéis laterais do produto podem estar quentes; de tempo ao produto para arrefecer antes de lhe tocar. Siga devidamente as instruções de montagem. Não permita a entrada de líquidos e de objectos estranhos no produto. <p>A não observância destas precauções pode provocar a morte, ferimentos graves ou danos materiais.</p> |

|  DANGER / PELIGRO / DANGER / GEFAHR / PERICOLO / PERIGO | | | | | |
|--|--|---|---|--|---|
| HAZARD OF ELECTRIC SHOCK, EXPLOSION, OR ARC FLASH. <ul style="list-style-type: none"> Disconnect all power before installing or working with this equipment. Verify all connections and replace all covers before turning on power. <p>Failure to follow these instructions will result in death or serious injury.</p> | RIESGO DE DESCARGA ELECTRICA O EXPLOSION. <ul style="list-style-type: none"> Desconectar todos los suministros de energía a este equipo antes de trabajar con este equipo. Verificar todas las conexiones y colocar todas las tapas antes de energizar el equipo. <p>El incumplimiento de estas instrucciones puede provocar la muerte o lesiones serias.</p> | RISQUE DE DESCARGE ELECTRIQUE OU EXPLOSION <ul style="list-style-type: none"> Eteindre toutes les sources d'énergie de cet appareil avant de travailler dessus de cet appareil Vérifier tous connections, et remettre tous couverts en place avant de mettre sous <p>De non-suivi de ces instructions provoquera la mort ou des lésions sérieuses.</p> | GEFAHR EINES ELEKTRISCHE N SCHLAGES ODER EINER EXPLOSION. <ul style="list-style-type: none"> Stellen Sie jeglichen Strom ab, der dieses Gerät versorgt, bevor Sie an dem Gerät Arbeiten durchführen Vor der Inbetriebnahme alle Anschlüsse überprüfen und alle Gehäuseeteile montieren. <p>Unterlassung dieser Anweisungen können zum Tode oder zu schweren Verletzungen führen.</p> | RISCHIO DI SCOSSA ELETTRICA O DELL'ESPLOSIONE. <ul style="list-style-type: none"> Spenga tutta l'alimentazion e che fornisce questa apparecchiatura prima del lavorare a questa apparecchiatura Verificare tutti i collegamenti e sostituire tutte le coperture prima della rotazione sull'alimentazione <p>L'omissione di seguire queste istruzioni provocherà la morte o di lesioni serie</p> | RISCO DE DESCARGA ELÉTRICA OU EXPLOSÃO <ul style="list-style-type: none"> Desconectar o equipamento de toda a energia antes de instalar ou trabalhar com este equipamento Verificar todas as conexões e recolocar todas as tampas antes de religar o equipamento <p>O não cumprimento destas instruções pode levar a morte ou lesões sérias.</p> |

ANNEX - ENVIROMENTAL INFORMATION

The environmental information disclosed in this annex including the EIP Pollution logo are in compliance with People's Republic of China Electronic Industry Standard SJ/T11364 – 2006, Marking for Control of Pollution Caused by Electronic Information Products.

| Part Name | Toxic or hazardous Substance and Elements | | | | | |
|-------------------|---|--------------|--------------|-------------------------------|--------------------------------|---------------------------------------|
| | Lead (Pb) | Mercury (Hg) | Cadmium (Cd) | Hexavalent Chromium (Cr (VI)) | Polybrominated biphenyls (PBB) | Polybrominated diphenyl ethers (PBDE) |
| Semiconductor die | X | 0 | 0 | 0 | 0 | 0 |
| Solder | X | 0 | 0 | 0 | 0 | 0 |

此附件所标示的包括电子信息产品污染图标的环保信息符合中华人民共和国电子行业标准 **SJ/T11364 - 2006**, 电子信息产品污染控制标识要求

| 部件名称 | 有毒有害物质或元素 | | | | | |
|-------|-----------|--------|--------|---------------|------------|--------------|
| | 铅 (Pb) | 汞 (Hg) | 镉 (Cd) | 六价铬 (Cr (VI)) | 多溴联苯 (PBB) | 多溴二苯醚 (PBDE) |
| 半导体芯片 | X | 0 | 0 | 0 | 0 | 0 |
| 焊接点 | X | 0 | 0 | 0 | 0 | 0 |



Obso