

V3 83161 Dual-current Dual-current 831618 Part number 83161806



- Minimum rating 1 mA / 4 VDC
- Operating temperature up to +125 °C
- Conforming to EN 61058 and UL 1054
- Choice of actuators with 4 possible fixing positions

Part numbers

Type	Function	Connections
83161806 Dual-current 831618	I (Changeover)	W3

Specifications

Electrical characteristics

Rating nominal / 250 VAC (A)	0,1
Rating thermal / 250 VAC (A)	6

Mechanical characteristics

Maximum operating force (N)	0,8
Min. Release force (N)	0,2
Maximum total travel force (N)	2
Max. permitted overtravel force (N)	20
Maximum rest position (mm)	16,2
Operating position (mm)	14,7 ^{±0,3}
Maximum differential travel (mm)	0,35
Min. overtravel CRA (mm)	1,2
Ambient operating temperature (°C)	-20 → +125
Mechanical life for 2/3 CRA (operations)	2 x 10 ⁷
Contact gap (mm)	0,4
Weight (g)	5,6

Additional specifications

Components

Material

- Housings : polyamide or polyester
- Button : polyamide
- Contacts : gold alloy

Levers

- Flat : stainless steel
- Roller : stainless steel, glass-filled polyamide roller
- Other polyamides

Approvals : NF

Principles

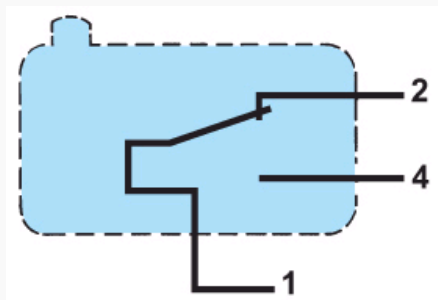

Dimensions (mm)

Product

83161

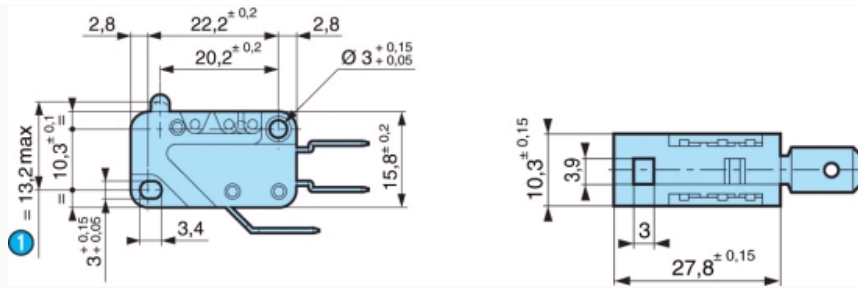

N°	Legend
1	OL

Dimensions (mm)

Connections

W2 solder

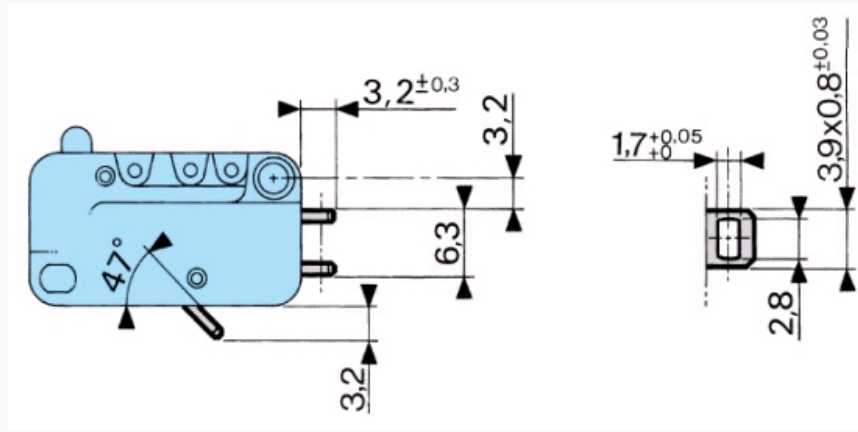

Dimensions (mm)

Connections

W3 (6.3 x 0.8) for 6.35 mm clips

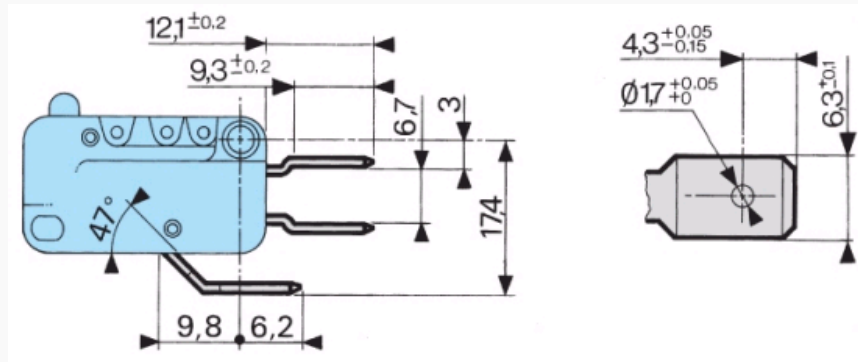

Dimensions (mm)

Connections

W3R5 (6.3 x 0.8) for 6.35 mm clips

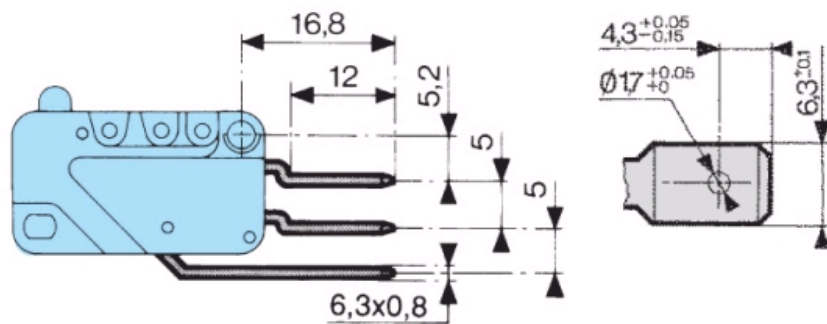

Dimensions (mm)

Connections

W5 screw

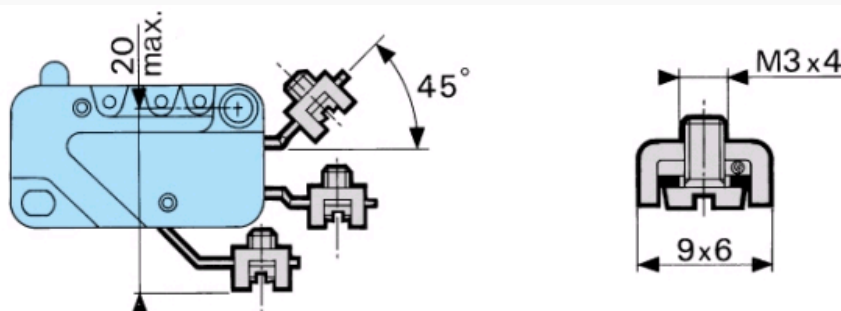

Dimensions (mm)

Connections

W6A5 (4.8 x 0.5) for 4.8 mm clips

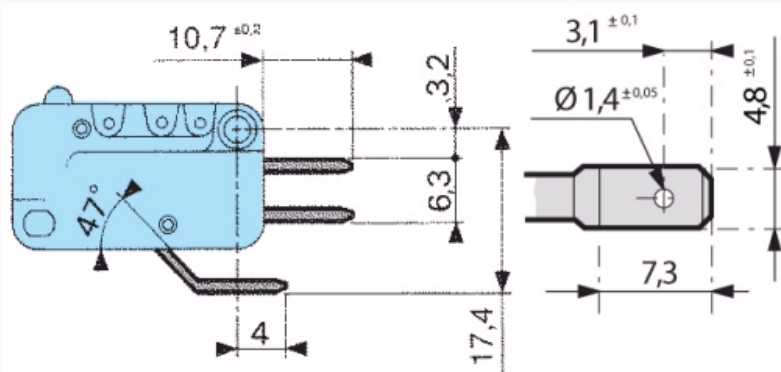

Dimensions (mm)

Connections

W6D8 (4.8 x 0.8) for 4.8 mm clips

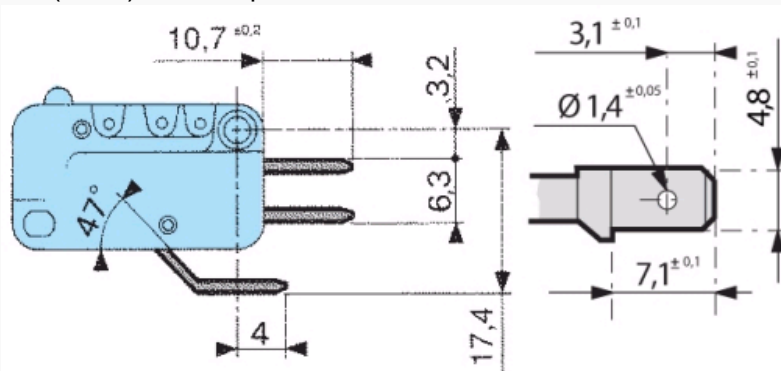

Dimensions (mm)

Connections

W7A5 (2.8 x 0.5) for 2.8 mm clips

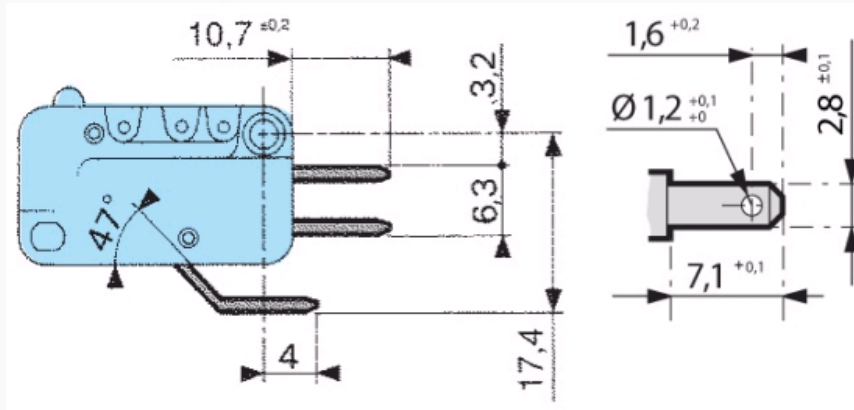

Dimensions (mm)

Connections

2W7A8 2 x (2.8 x 0.8) for 2.8 mm clips

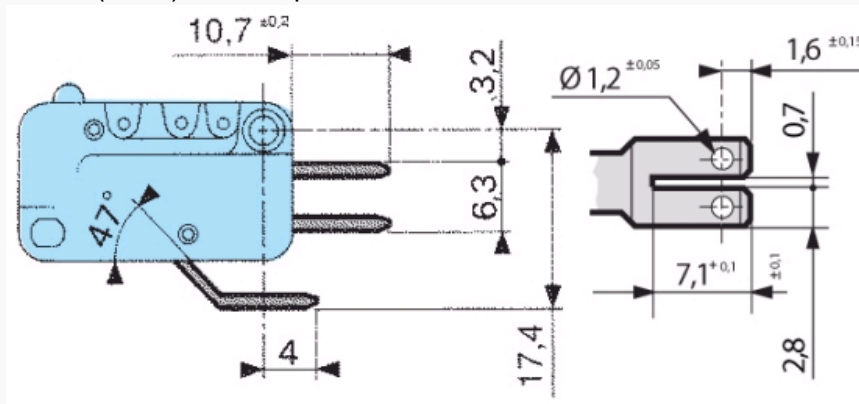

Dimensions (mm)

Actuator mounting positions

Levers

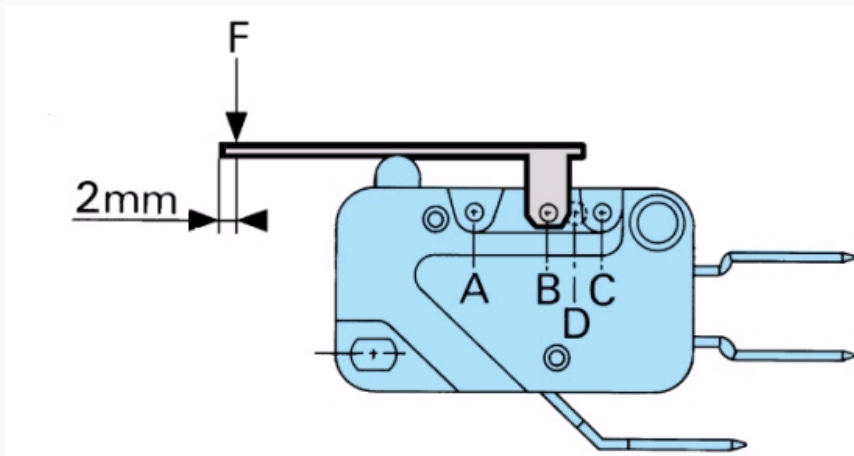

To calculate force Divide the switch force by the coefficient given in the table. To calculate travel Multiply the switch travel by the same coefficient. Example : 83 161 8 with lever 161 A - R 25.4 position A (coeff. 4) Operating force : $0.8 : 4 = 0.2$ N Pre-travel : $1.4 \times 4 = 5.6$ mm

Dimensions (mm)

Actuator mounting positions

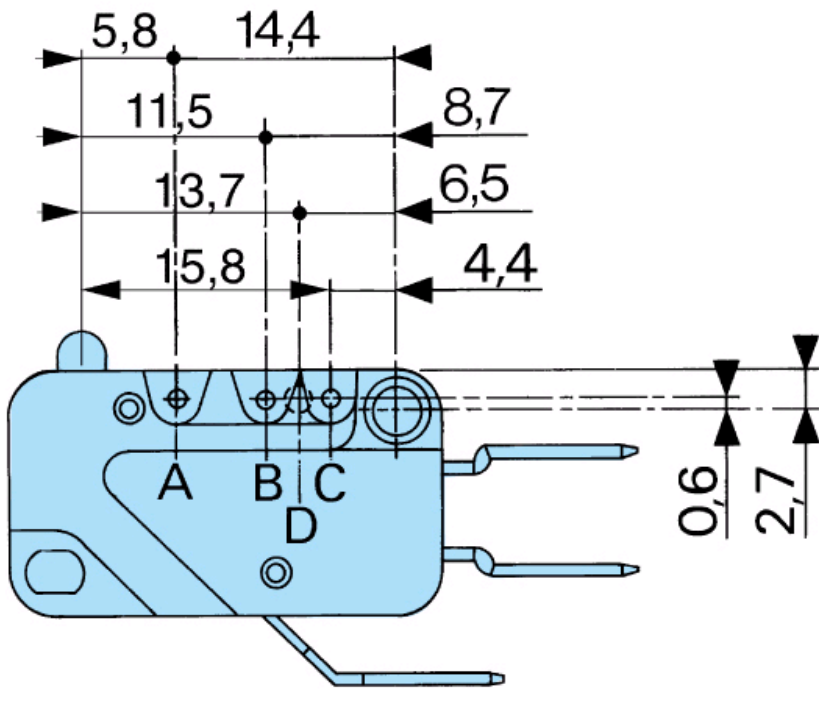

To calculate force Divide the switch force by the coefficient given in the table. To calculate travel Multiply the switch travel by the same coefficient. Example : 83 161 8 with lever 161 A - R 25.4 position A (coeff. 4) Operating force : $0.8 : 4 = 0.2$ N Pre-travel : $1.4 \times 4 = 5.6$ mm

Dimensions (mm)

Actuators

161 E

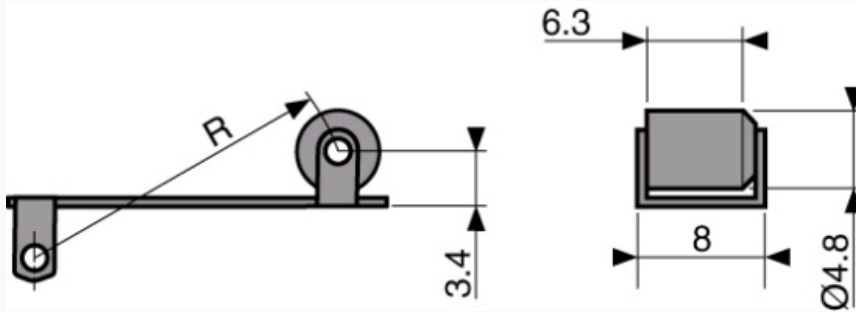

To calculate force Divide the switch force by the coefficient given in the table. To calculate travel Multiply the switch travel by the same coefficient. Example : 83 161 8 with lever 161 A - R 25.4 position A (coeff. 4) Operating force : $0.8 : 4 = 0.2$ N Pre-travel : $1.4 \times 4 = 5.6$ mm

Dimensions (mm)

Actuators

161 L

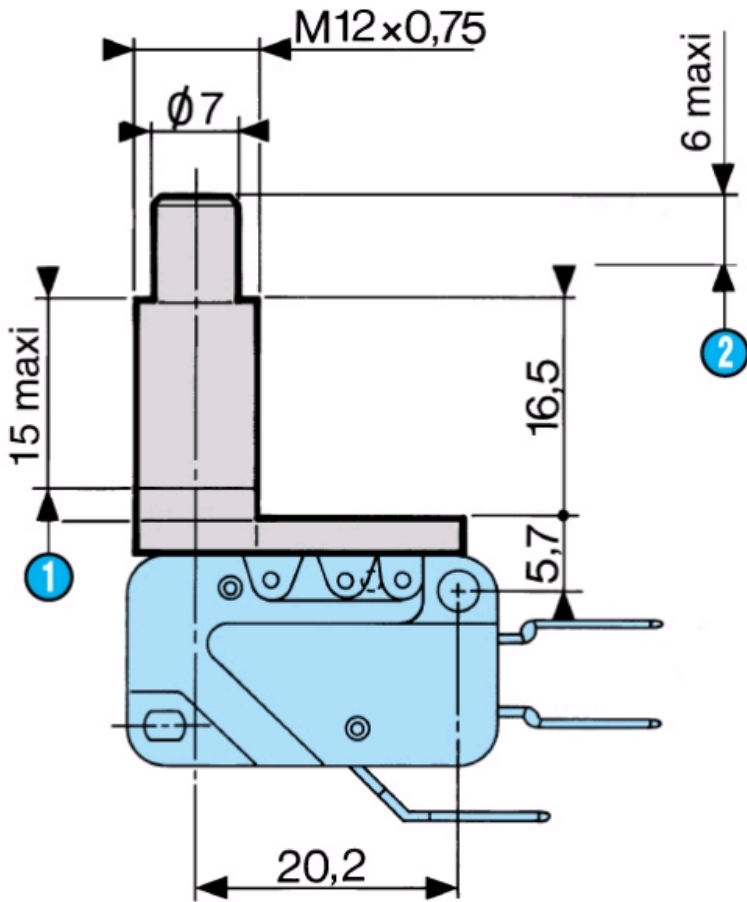

Nut thickness Max. torque 1.5 mm 5 Cm N 2 mm 7 Cm N 2.5 mm 10 Cm N

N°	Legend
1	Thread
2	Total travel

Dimensions (mm)

Actuators

161 V

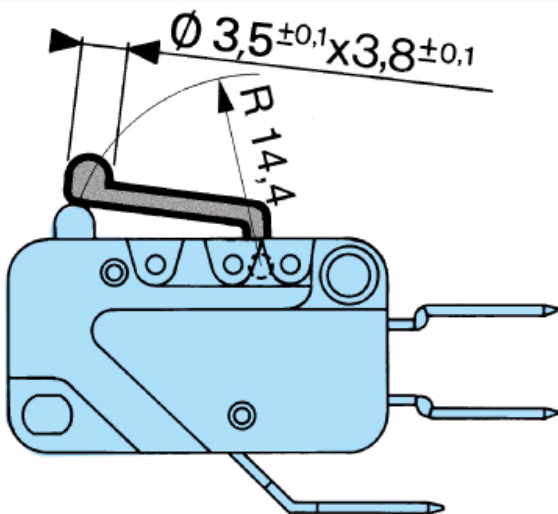

Nut thickness Max. torque 1.5 mm 5 Cm N 2 mm 7 Cm N 2.5 mm 10 Cm N

Dimensions (mm)

Actuators

161 F

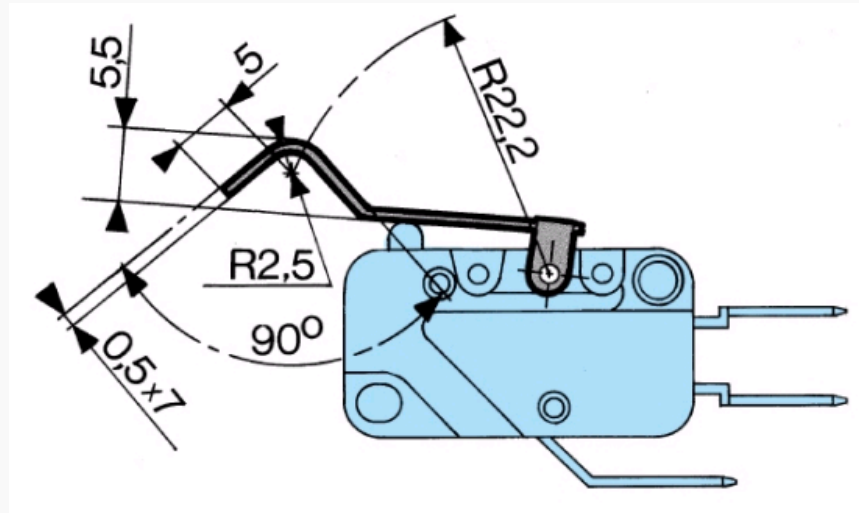

Nut thickness Max. torque 1.5 mm 5 Cm N 2 mm 7 Cm N 2.5 mm 10 Cm N

Dimensions (mm)

Actuators

161 G

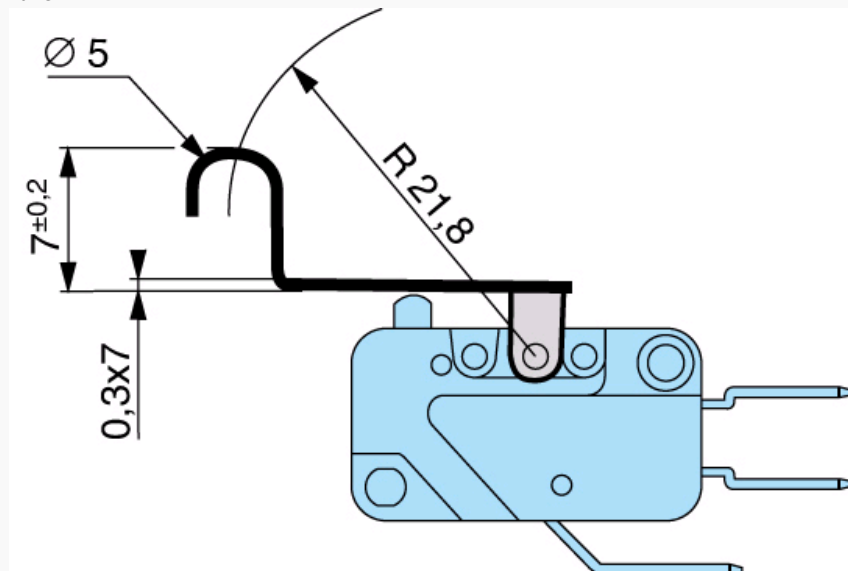

Nut thickness Max. torque 1.5 mm 5 Cm N 2 mm 7 Cm N 2.5 mm 10 Cm N

Dimensions (mm)

Mounting accessories

Nut 70602118

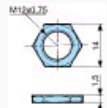

Nut thickness Max. torque 1.5 mm 5 Cm N 2 mm 7 Cm N 2.5 mm 10 Cm N

Dimensions (mm)

Mounting accessories

Housing 161 J for connections W3 R5

Part numbers for standard actuators	79 215 740		70 507 524			79 215 742		70 507 529			70 507 528	
Actuators	Plain 161A R14,2		Plain 161A R25,4			Roller 161E R13,6		Roller 161E R24,1			Dummy roller 161F R22,2	
Fixing positions	A	B	A	B	C	A	B	A	B	C	A	B
Coefficient	2	1	4	2	1,5	2	1	4	2	1,5	3	1,8
Tripping point (except 83 161 6)	15,2 ^{±1}	15,2 ^{±0,45}	15,2 ^{±0,3}	15,2 ^{±1}	15,2 ^{±0,8}	20,5 ^{±1,3}	20,5 ^{±0,8}	20,5 ^{±0,9}	20,5 ^{±1,3}	20,5 ^{±1,2}	20,4 ^{±2}	20,4 ^{±0,7}
Tripping point 83 161 6	14,8 ^{±1}	15 ^{±0,5}	14,4 ^{±0,5}	14,8 ^{±1}	14,9 ^{±0,8}	20,1 ^{±1,3}	20,3 ^{±0,8}	19,7 ^{±0,9}	20,1 ^{±1,3}	20,2 ^{±1,2}	20,2 ^{±2}	20,2 ^{±2}
Part numbers for standard actuators	79 218 651											
Actuators	Dummy roller 161G R21,8		**Telescopic plunger 161 L			Manual action		161V		Housing 161J		Nut for 161L Part no.: 70 602 118
Fixing positions	A	B	D			D		D		D		
Coefficient	3	1,8	1			1		1		1		
Tripping point (except 83 161 6)	21,7 ^{±2}	21,7 ^{±0,7}	21,5 ^{±1}			18,35 ^{±0,5}		18,35 ^{±0,5}		18,35 ^{±0,5}		
Tripping point 83 161 6	21,5 ^{±2}	21,5 ^{±0,7}	21,5 ^{±1}			18,35 ^{±0,5}		18,35 ^{±0,5}		18,35 ^{±0,5}		

Except where otherwise indicated, plain and roller levers are supplied unmounted.

For factory mounting, specify fixing position A, B or C.

** For 83 161 1, 83 161 2, 83 161 3, 83 161 6 mounted in factory (supplied without nut)

Other information

Mounting - Operation

See basic technical concepts

Product adaptations



- Special levers
- Special connections
- Specific fixing
- High operating temperature
- Special operating force
- Approvals : UL - cUL