

HARDWARE

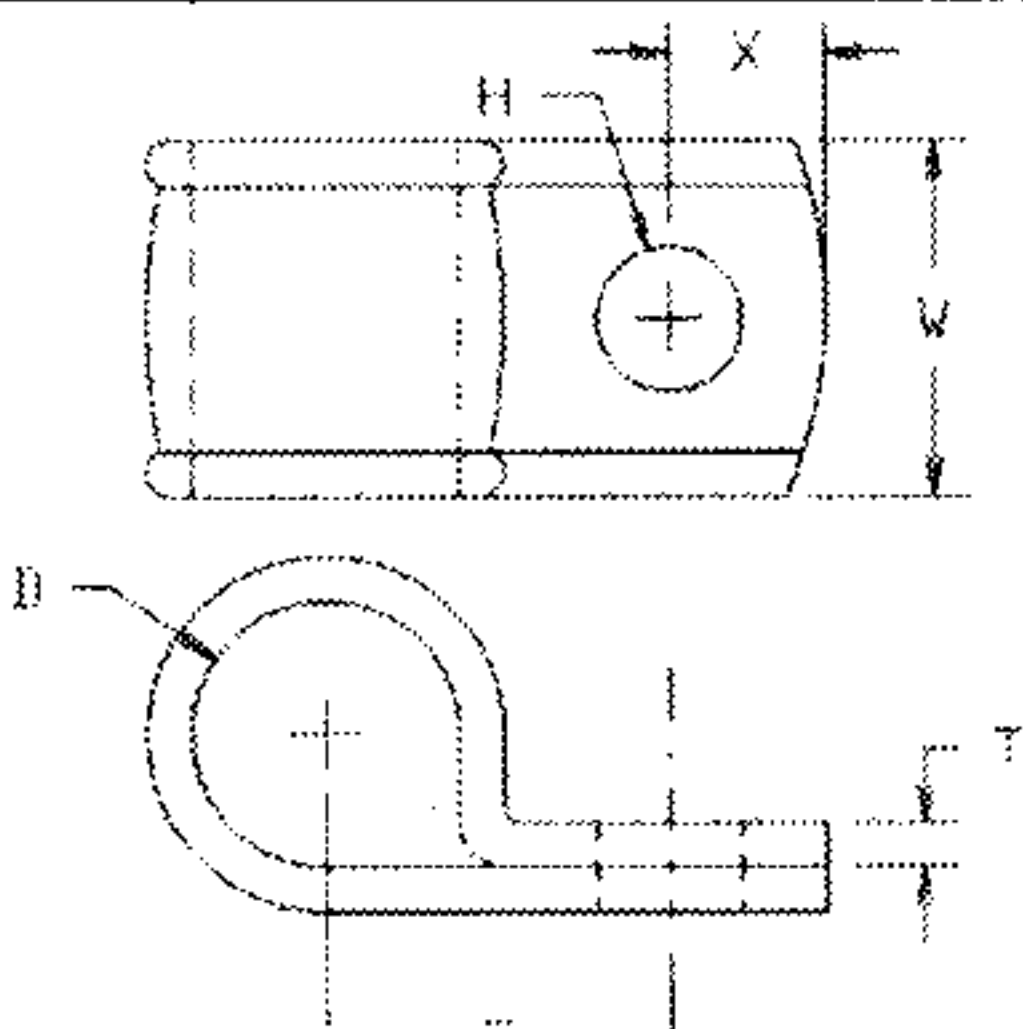

PROPIONATE CELLULOSE

T=.060 X=7/32" COLOR: CLEAR
W=1/2" H=.204

PART NO.	HOLE (D)	E
770-1501	1/8	.328
770-1502	3/16	.390
770-1503	1/4	.421
770-1504	5/16	.453
770-1505	3/8	.483
770-1506	7/16	.531
770-1507	1/2	.562
770-1508	9/16	.593
770-1509	5/8	.625
770-1510	11/16	.656
770-1511	3/4	.765
770-1512	7/8	.812
770-1513	1	.906
770-1514	1-1/8	.968
770-1515	1-1/4	1.062

NYLON- BLACK

HOLE D 1/8" TO 1/2" HOLE D 9/16" TO 1-1/4"
T=.040 X=5/32" T=.060 X=13/64"
W=3/8" H=.167 W=1/2" H=.204

PART NO.	HOLE (D)	E
770-1601	1/8	.310
770-1602	3/16	.373
770-1603	1/4	.407
770-1604	5/16	.448
770-1605	3/8	.479
770-1606	7/16	.510
770-1607	1/2	.542
770-1608	9/16	.623
770-1609	5/8	.654
770-1610	11/16	.752
770-1611	3/4	.783
770-1612	7/8	.845
770-1613	1	.908
770-1614	1-1/8	1.002
770-1615	1-1/4	1.062

COMPONENT CLIPS

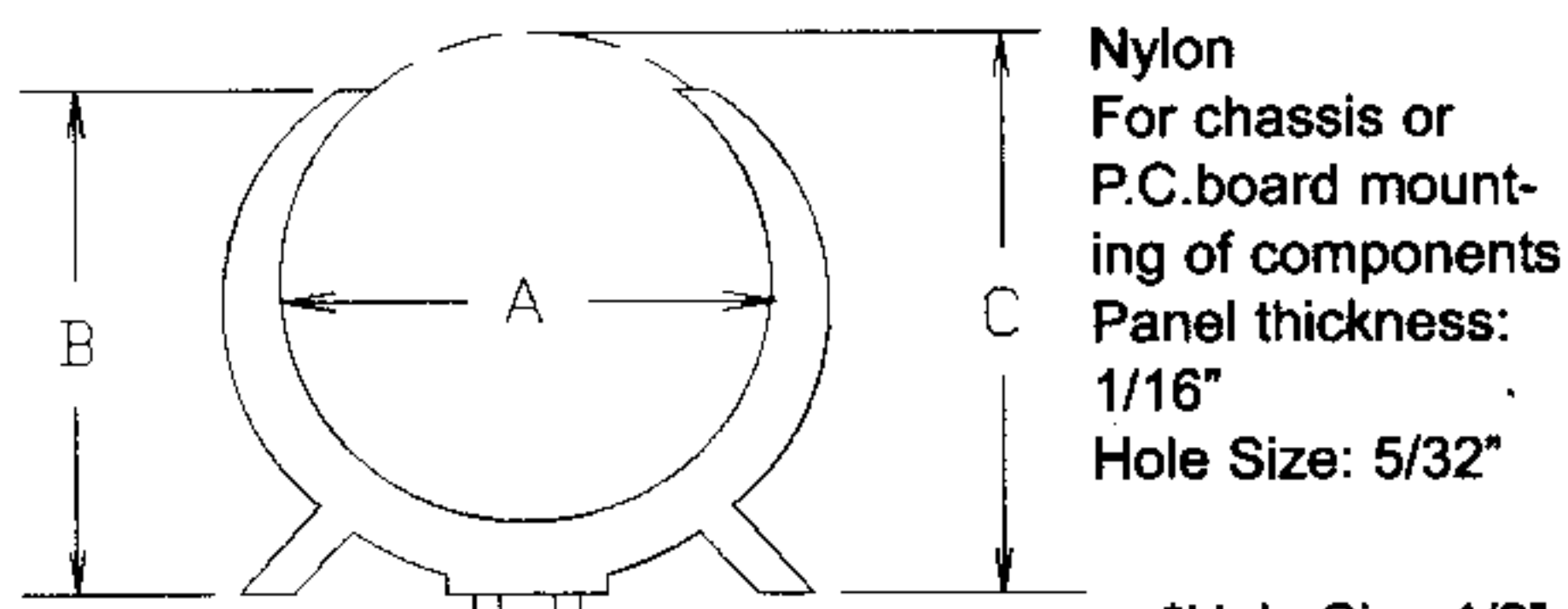

PART NO.	A	B	C
770-4001*	.218	.265	.343
770-4004	.375	.437	.500
770-4006	.500	.546	.625
770-4008	.625	.685	.750
770-4011	.800	.781	.925
770-4012	1.000	1.000	1.125

*Hole Size 1/8"

HALF U CLIPS

PVC MATERIAL COLOR: BLACK

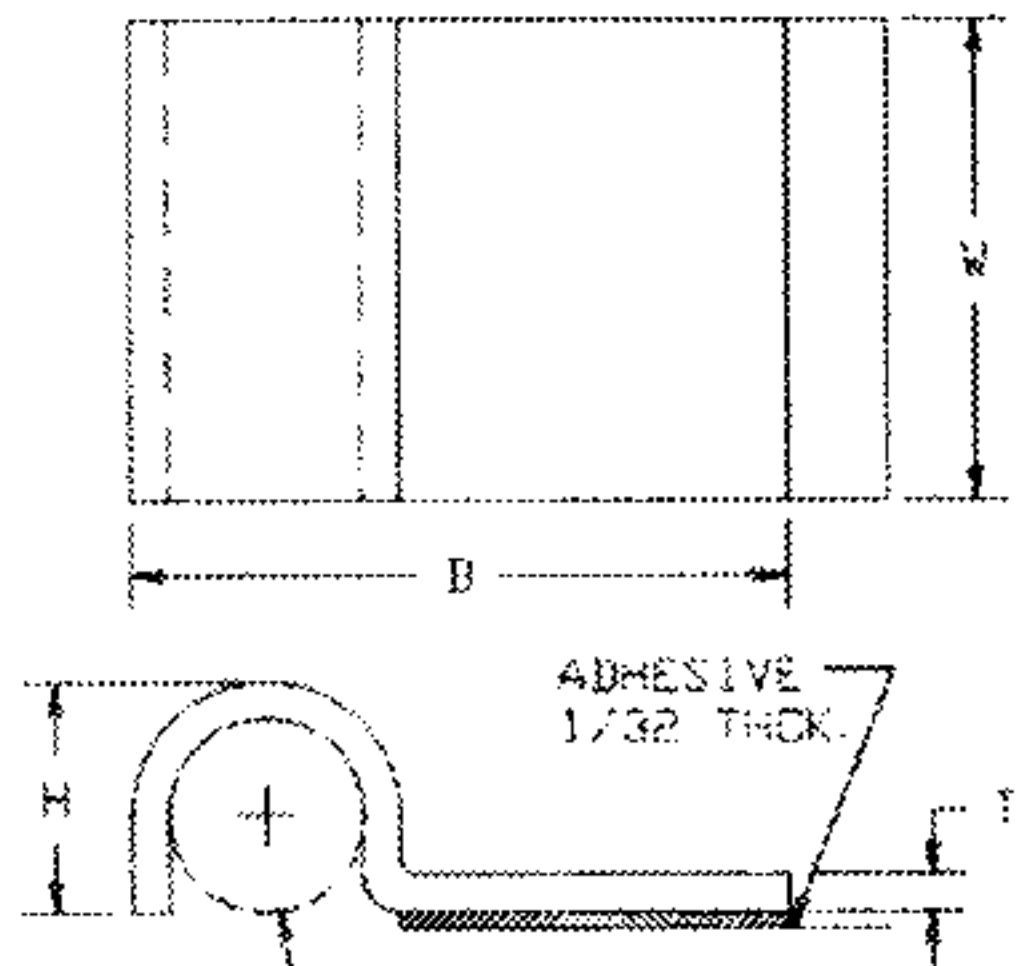

T=.047
W=5/8

PART NO	D	B	H
770-2040	1/8	23/32	11/64
770-2041	1/4	27/32	19/64
770-2042	3/8	31/32	27/64
770-2043	1/2	1-3/32	35/64

CABLE CLAMPS PLATED STEEL CABLE CLAMPS

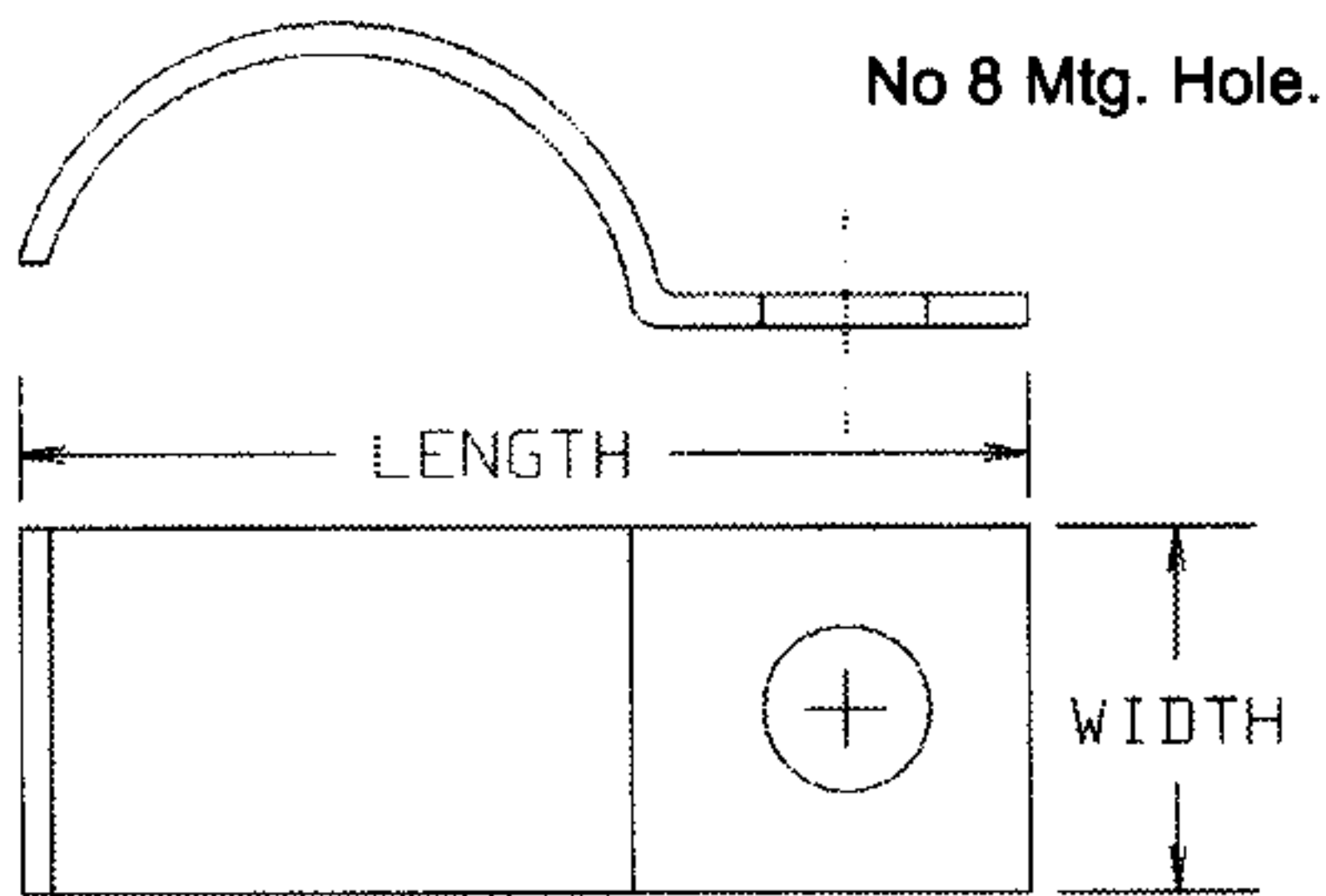

PART NO.	LENGTH	WIDTH	CABLE
770-1421	5/8	3/8	1/8
770-1420	3/4	3/8	1/4
770-1422	1	3/8	1/2

FLAT WIRE CABLE CLAMPS

Self-extinguishing PVC with self-cohesive back for quick installation of flat cable

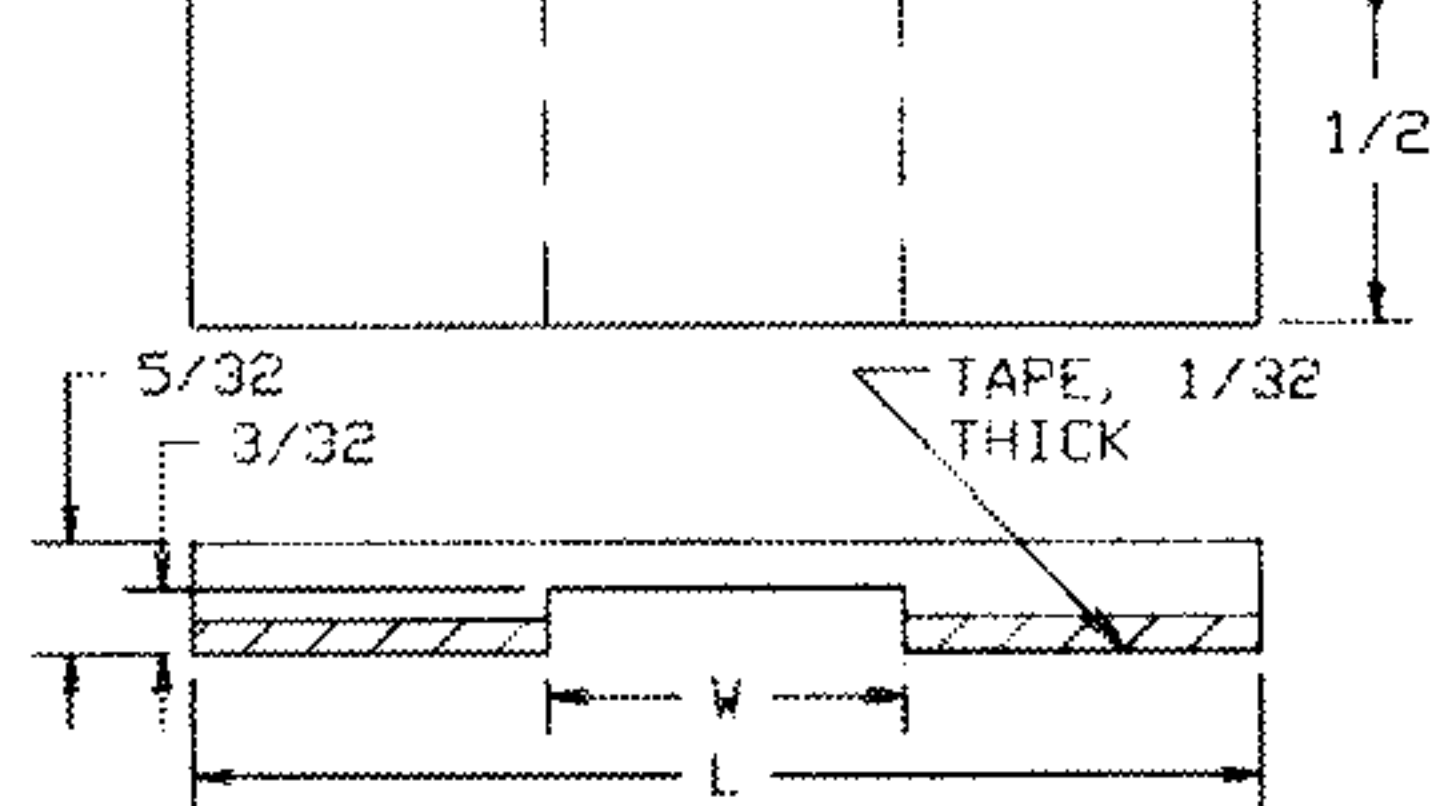

PART NO.	CLAMP WIDTH "L"	CLAMP WIDTH "W"
770-4401	1-1/2	1/2
770-4402	2	1
770-4403	3	2
770-4404	4	3

FLAT WIRE CABLE CLAMPS ROUTING TYPE

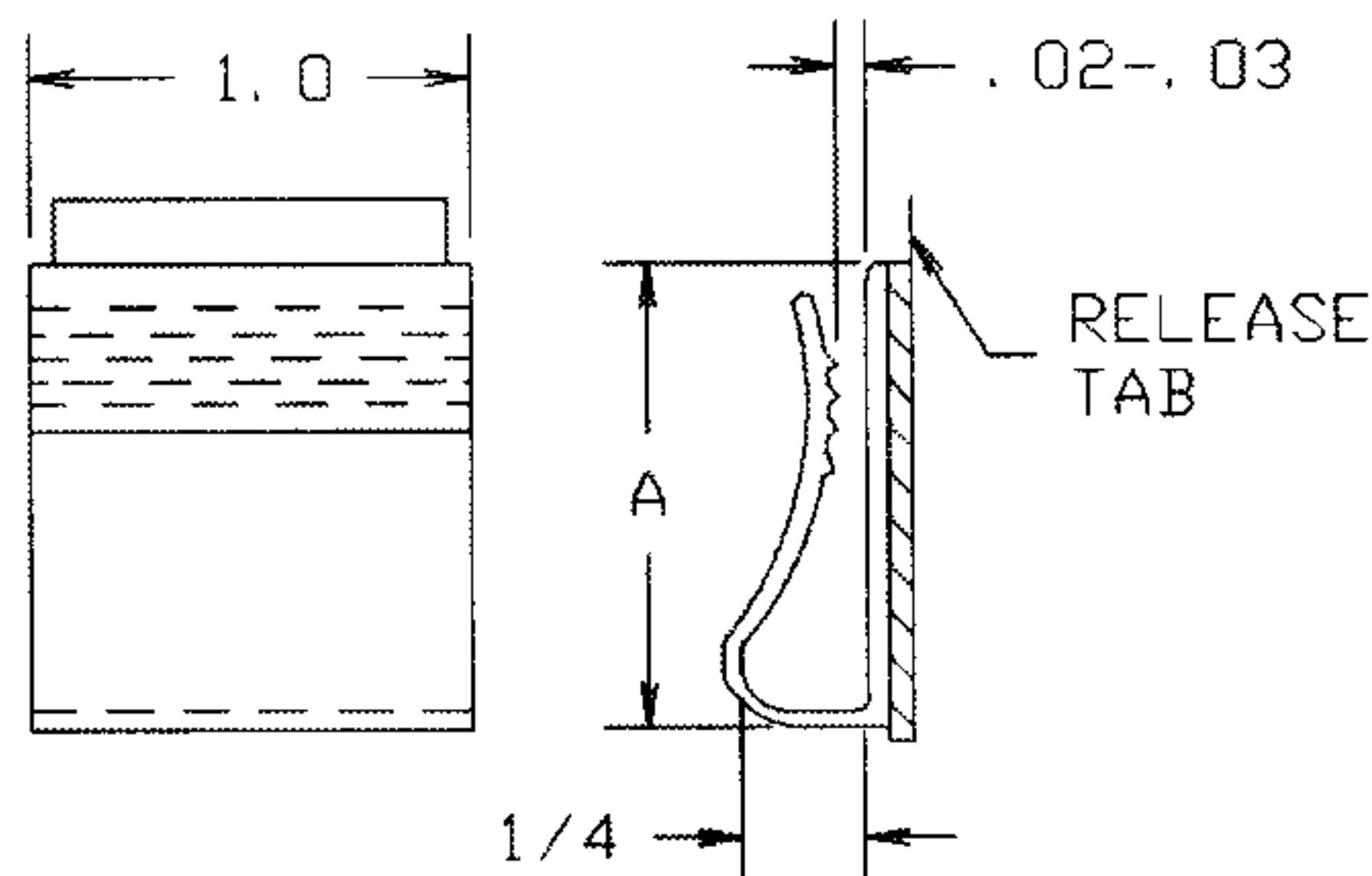

TAPE 1/16" THICKNESS
PART NO. WIDTH "A"
770-4410 9/16
770-4411 1-1/16

NORYL WITH SERRATED GRIPPER AND SELF-ADHESIVE BACK FOR FLAT OR WOVEN CABLES

NYLON "HALF" CABLE CLAMPS

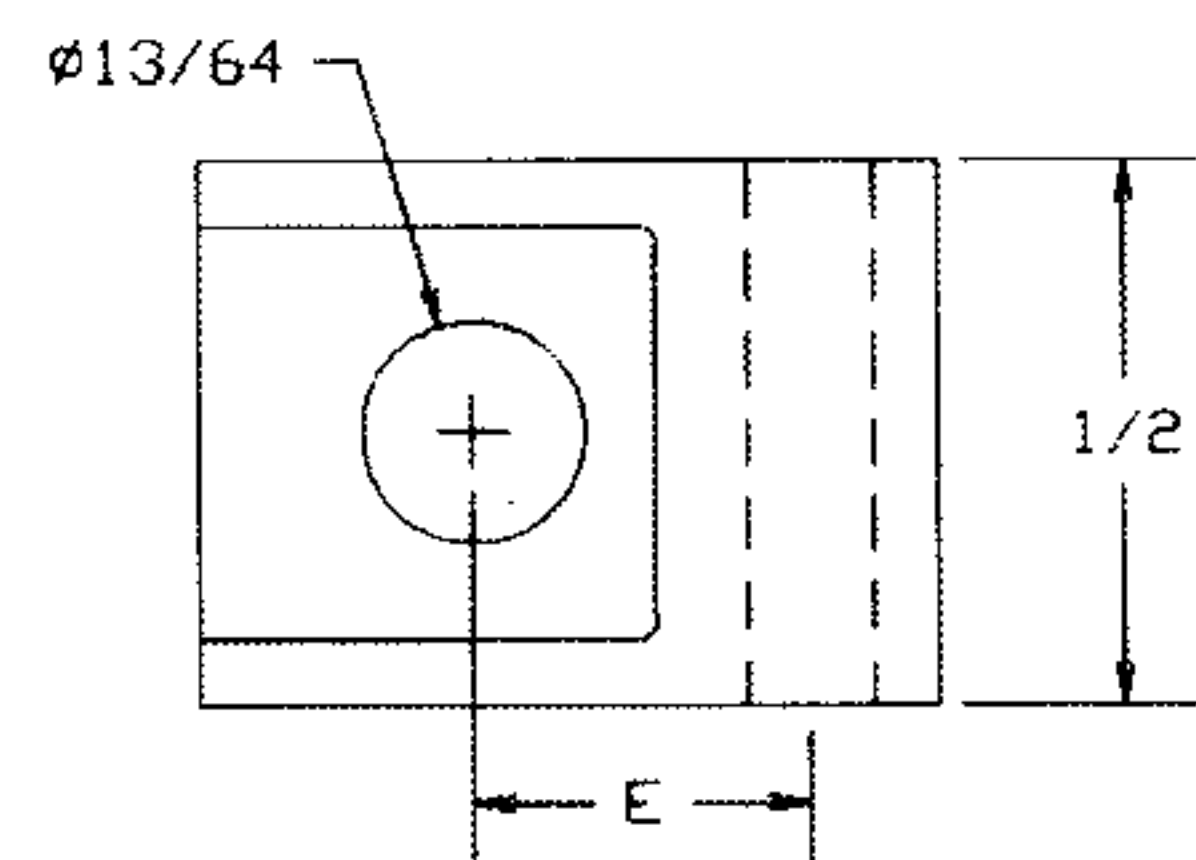

Solvent resistant Nylon, unaffected by most solvents, alkalis, dilute mineral acids & most organic acids
COLOR BLACK

Q. 060

PART NO	WIRE SIZE	A	B	E	F (REF)
770-1401	1/8	.115	.115	.307	.675
770-1402	3/16	.172	.172	.328	.732
770-1403	1/4	.234	.234	.366	.793
770-1404	5/16	.297	.297	.400	.859
770-1405	3/8	.359	.359	.430	.920
770-1406	7/16	.422	.422	.460	.980
770-1407	1/2	.484	.484	.492	1.044

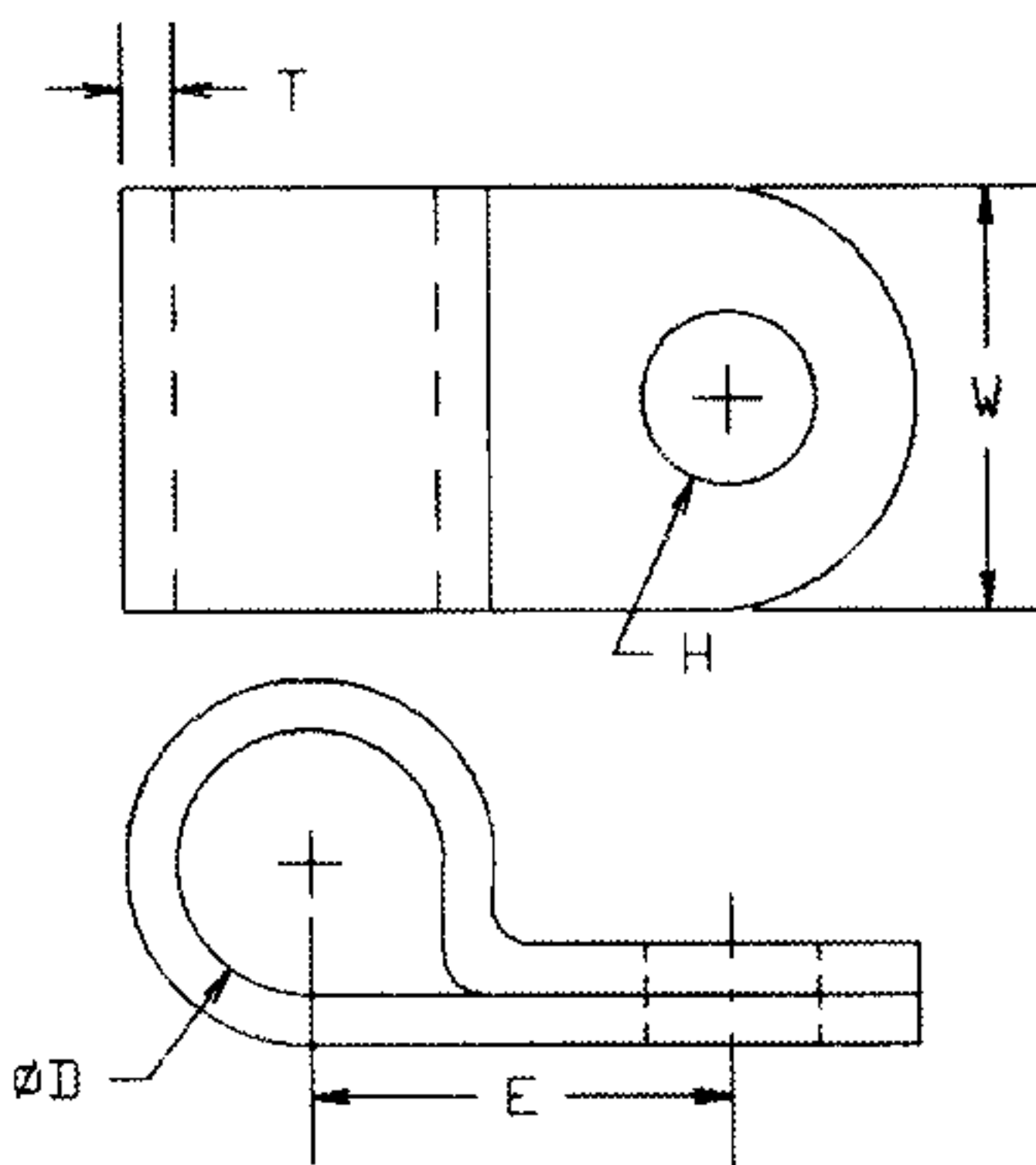

POLYPROPYLENE

T=.050" W=1/2 H=13/64"

PART NO	HOLE (D)	E
770-1001	1/8	.360
770-1002	3/16	.423
770-1003	1/4	.457
770-1004	5/16	.498
770-1005	3/8	.529
770-1006	7/16	.560
770-1007	1/2	.592
770-1008	9/16	.623
770-1009	5/8	.654
770-1010	11/16	.752
770-1011	3/4	.783
770-1012	7/8	.845
770-1013	1	.908

PROPIONATE AMBER

T=.060" W=1/2 H=13/64"

PART NO	HOLE (D)	E
770-1101	1/8	.328
770-1102	3/16	.390
770-1103	1/4	.421
770-1104	5/16	.453
770-1105	3/8	.483
770-1106	7/16	.531
770-1107	1/2	.562
770-1108	9/16	.593
770-1109	5/8	.625
770-1110	11/16	.656
770-1111	3/4	.765
770-1112	7/8	.812
770-1113	1	.906

NYLON

T=.050" W=1/2 H=13/64"

PART NO	HOLE (D)	E
770-1201	1/8	.360
770-1202	3/16	.423
770-1203	1/4	.457
770-1204	5/16	.495
770-1205	3/8	.529
770-1206	7/16	.560
770-1207	1/2	.592
770-1208	9/16	.623
770-1209	5/8	.654
770-1210	11/16	.783
770-1211	3/4	.780
770-1212	7/8	.845
770-1213	1	.908
770-1214	1-1/8	.970
770-1215	1-1/4	1.060

T=.050" W=3/8 H=13/64"

PART NO	HOLE (D)	E
770-1301	1/8	.325
770-1302	3/16	.378
770-1303	1/4	.409
770-1304	5/16	.441
770-1305	3/8	.595
770-1306	7/16	.574
770-1307	1/2	.550

T=.050" W=3/8 H=9/64"

PART NO	HOLE (D)	E
770-1308	.125	.325
770-1309	.187	.380
770-1310	.250	.410
770-1311	.312	.445
770-1312	.375	.475
770-1313	.437	.525
770-1314	.500	.550