

| DATE   | SYM | REVISION RECORD | AUTH. | DR. | CK. |
|--------|-----|-----------------|-------|-----|-----|
| 3/1/02 | -   | ISSUED          | JL    | NT  | JL  |
|        |     |                 |       |     |     |
|        |     |                 |       |     |     |
|        |     |                 |       |     |     |

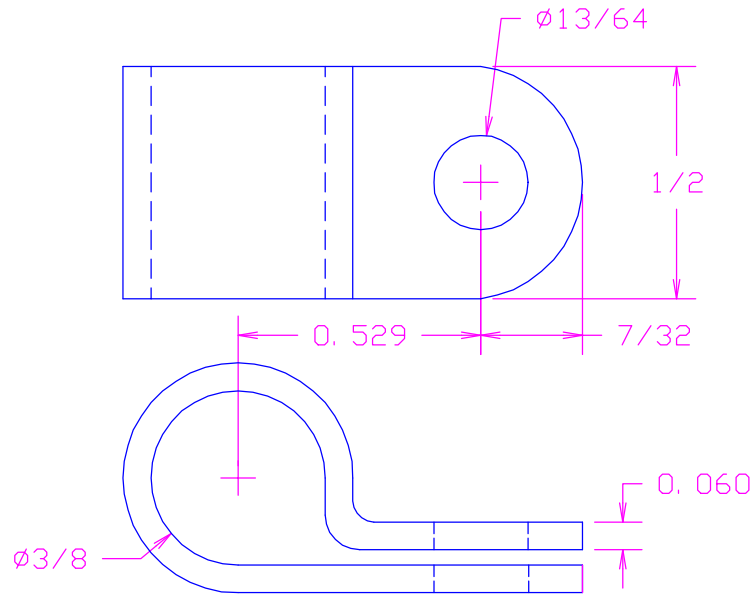

MATERIAL: POLYPROPYLENE

ACTUAL SIZE

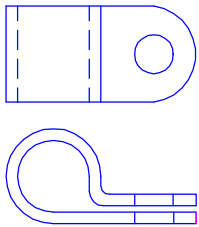

|                                 |                      |                            |  |
|---------------------------------|----------------------|----------------------------|--|
| TOLERANCES<br>(EXCEPT AS NOTED) | CONCORD              |                            | ELECTRONICS<br>CORPORATION                 |
| DECIMAL<br>$\pm .010$           | P/N                  | SCALE                      | 30 GREAT JONES ST.<br>NEW YORK N. Y. 10012 |
| FRACTIONAL<br>$\pm 1/64$        | TITLE<br>CABLE CLAMP |                            |  |
| ANGULAR<br>$\pm$                | DATE<br>3/1/02       | DRAWING NUMBER<br>770-1005 |  |