



AC CAPACITORS FOR MOTOR RUN APPLICATIONS

Proven EIA-456-A Compliant 60,000 Hour
Reliability Industry Standard

Descriptive Information	2
Product Safety	3
Motor Run Capacitors – GEM III	
Product Specifications	5
Single Ratings – 1 Section	6
Dual Ratings – 2 Sections	8
Dual Ratings – 2 Concentric Sections	10
Application Data	12
Outline	13
Capacitor Label	14

Capcom Capacitors Capacitors for Motor Run Applications

Genteq metallized film capacitors are unsurpassed in terms of size, weight, performance, and reliability for AC applications. Capcom over 60 year of capacitor manufacturing experience to the product lines described in this publication. These capacitors represent the best in product design for long-term reliability and safe operation. Capcom's materials, product, and process development work continue to provide capacitor users with outstanding total value.

The GEM III Motor Run Capacitors are widely used with permanent split phase capacitor motors for the more efficient use of electricity. These motors are used in heating and cooling equipment, appliances, business machines, office equipment, and a wide variety of light commercial and industrial equipment.

GEM III Construction

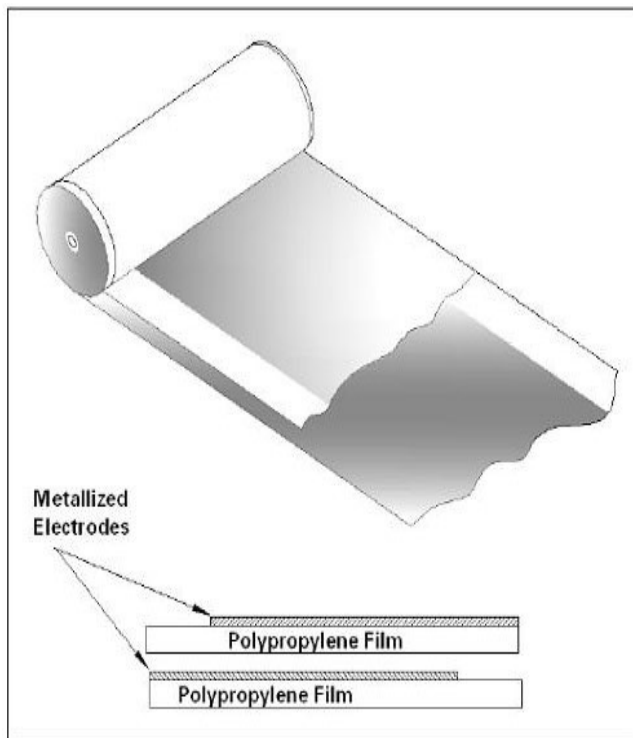

Capcom's GEM III capacitors are manufactured with high-grade metallized polypropylene film. This film is in the range of 5 to 10 microns thick, depending on the application, voltage, and conditions. The metallized electrode is several hundred angstroms thick.

The film is wound into capacitor rolls on high-speed, high-precision machines. The winding is extremely tight so that there is not enough space between the layers for corona (localized partial electrical discharges) to occur. The rolls are sprayed on both ends with metal to make the connection to the extremely thin edges of the metallized electrodes. This process is critical to the quality and performance of the capacitors.

The rolls are assembled in metal cases, Capcom's proprietary dielectric liquid is introduced under vacuum, and the capacitors are sealed. They are then subjected to 100% electrical testing for capacitance, dissipation factor, and high potential electrical withstand, both terminal-to-terminal and terminal-to-case.

Pressure Sensitive Interrupter

All the capacitors listed in this publication contain Capcom's Pressure Sensitive Interrupter (PSI). This device, is designed to sense the build-up of pressure within the capacitor if a fault occurs and to interrupt the internal electrical connections before the case can rupture.

The PSI carries U.L.* recognition for applications where the specified fault currents are not exceeded. The fault current is the maximum current that is available from the circuit to flow through the capacitor if the capacitor were to become a short circuit with zero impedance. It is the responsibility of the capacitor user to determine what the available fault current is for a particular application.

In the Catalog Number listings a four character U.L. Code, Pxxx, is given. This number is part of the listing for Capcom in U.L. File No. E322597. When applying to U.L. for approvals or recognition of equipment using these capacitors refer to the Pxxx number and not the Catalog Number of the capacitor in question.

Proper operation of the PSI requires that the cover be able to expand without restriction. The following mounting considerations should be noted in mounting the these capacitors.

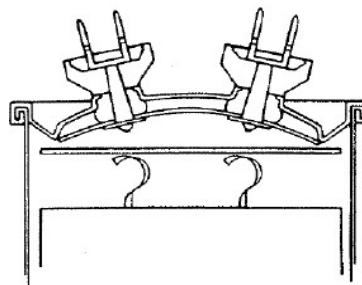
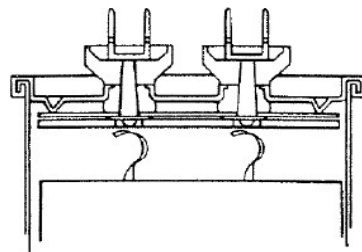

*Underwriter's Laboratory

Mounting Considerations

Vertical Clearance

There must be sufficient clearance between the tops of the terminals (and/or the assembled wire connectors) and a plane perpendicular to the capacitor terminals. This clearance must be at least 0.5 inches plus electrical spacing requirements of the end application.

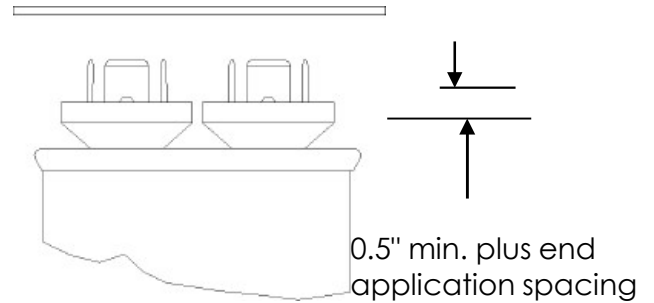

Case Style	a	b
A	2.00	1.00
B	2.25	1.25
C	2.50	1.62
D	3.25	1.62

Case Style	a
P	1.62
S	1.88
T	2.38

Cut-Out Clearance

In certain instances, capacitors are mounted with the top of the capacitors case resting against the chassis and the terminals protruding through the chassis. Care must be taken to see that the cutout in the chassis is large enough. The following dimensions are recommended.

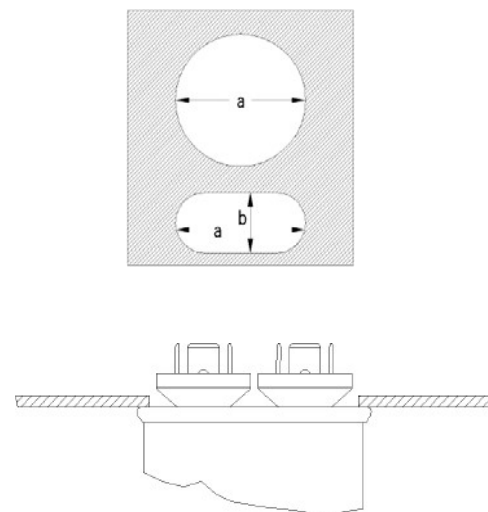

Motor Run Capacitors – GEM III

370 & 440 VAC



This capacitor series is designed specifically for the **motor run applications** where the capacitors are used in conjunction with permanent split capacitor type motors. They may be used on either 50 or 60-Hertz systems but should not be used at higher frequencies or in applications where higher frequency harmonics are present. For those types of applications the General Purpose AC Capacitors should be used. If there are any questions regarding the correct application of these products, please contact your Capcom sales representative.

SPECIFICATIONS:

Available Capacitance Range:	2 to 120µF (Special ratings upon request)
Capacitance Tolerance	±6%
Capacitance Variation with Temperature:	See Chart M-3 on page 14
Rated Voltage:	see RATING TABLES. RATING IS THE 50/60HZ RMS VOLTAGE for a sinusoidal waveform. (Special ratings upon request)
Leakage Current:	30µA maximum
Frequency	50/60 Hz. For higher frequencies use General Purpose AC Capacitor Series.
Operating Temperature:	-40°C to +70°C
Storage Temperature:	-40°C to +90°C
Operating Life:	60,000 hours with 94% survival (In accordance with the EIA-456 Industry Standard)
Dissipation Factor:	0.1% maximum
Case Material/Finish:	Unpainted Aluminum case, terne plate steel cover. Contact Capcom if material/finish to meet UL outdoor standards is required.
Terminations:	Combo' terminal: 0.250" x 0.031" quick connect blade:
Dielectric Fluid:	Proprietary dielectric oil
Internal Protection:	UL recognized Pressure Sensitive Interrupter.

Case Style	Capcom Code	Generic UL Code
A	P921	A10000AFC
C	P923	C10000AFC
D	P924	D10000AFC
P	P965	P10000AFC
S	P968	S10000AFC
T	P969	T10000AFC

See Ratings Table for Capcom's UL Code Number listed under Capcom's UL File E322597. For UL submittals with these capacitors, use the RBC 'Pxxx' number not the Catalog Number. The corresponding generic UL designation that includes the Available Faults Current (AFC) rating is given below. All these capacitors are capable of interrupting available fault currents of up to 10,000 amperes.



Motor Run Capacitors – GEM III

Single Ratings – 1 Section

Voltage (VAC)	Capacitance (µF)	Catalog Number	Case Style	Base Size (in.)	Can Type	Height C (in.)	UL Code
370	3.0	27L987	A	1.25	Oval	1.56	P921
	4.0	27L571	A	1.25	Oval	1.56	P921
	5.0	27L570	A	1.25	Oval	1.56	P921
	6.0	97F5706	A	1.25	Oval	2.12	P921
	7.5	27L566	A	1.25	Oval	2.12	P921
	10.0	97F9002	A	1.25	Oval	2.88	P921
	12.5	27L572	A	1.25	Oval	2.88	P921
	15.0	27L567	A	1.25	Oval	2.88	P921
	20.0	97F9602	P	1.75	Round	2.88	P965
	25.0	97F9606	P	1.75	Round	2.88	P965
	30.0	97F9608	P	1.75	Round	3.88	P965
	35.0	97F9611	P	1.75	Round	3.88	P965
	40.0	97F9614	P	1.75	Round	3.88	P965
	45.0	97F9884	P	1.75	Round	4.75	P965
	50.0	97F9802	P	1.75	Round	4.75	P965
	55.0	97F9010	S	2.00	Round	4.75	P968
	60.0	97F5276	T	2.50	Round	3.88	P969
	65.0	97F9011	T	2.50	Round	3.88	P969
	70.0	97F9012	T	2.50	Round	4.75	P969
	75.0	27L361	T	2.50	Round	4.75	P969
80.0	27L497	T	2.50	Round	4.75	P969	

Case Style A

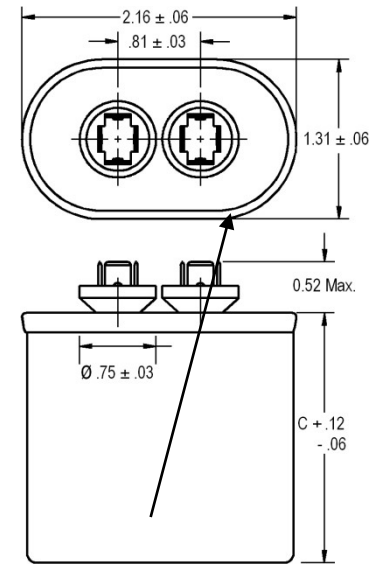

(4) .250 x .031
Blades per terminal

Case Style P,S and T

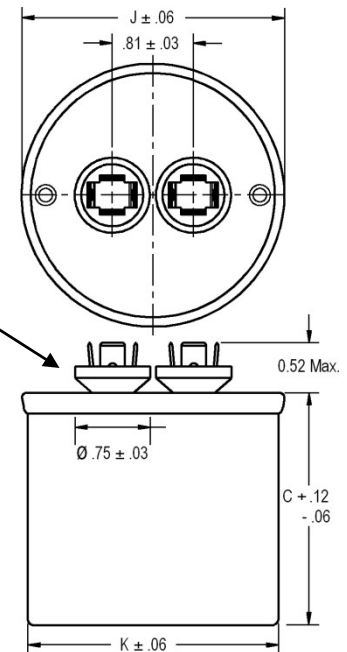

(4) .250 x .031 Blades per terminal except (3) on case style P

Case	K	J
P	1.75	1.88
S	2.00	2.12
T	2.50	2.62

Motor Run Capacitors – GEM III

Single Ratings – 1 Section

Case Style A

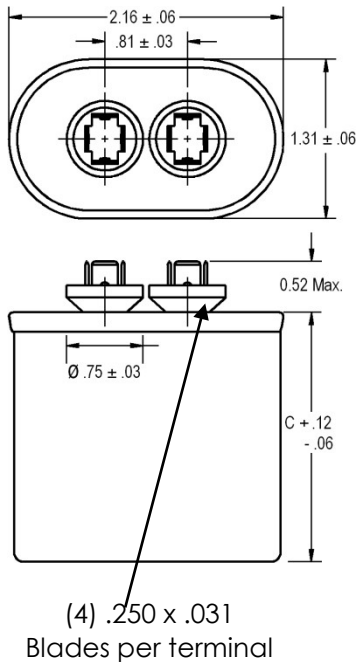

Voltage (VAC)	Capacitance (μ F)	Catalog Number	Case Style	Base Size (in.)	Can Type	Height C (in.)	UL Code
440	3.0	27L1022	A	1.25	Oval	1.56	P921
	4.0	27L1023	A	1.25	Oval	1.56	P921
	5.0	27L1024	A	1.25	Oval	2.12	P921
	6.0	27L1025	A	1.25	Oval	2.12	P921
	7.5	27L695	A	1.25	Oval	2.88	P921
	10.0	27L1027	A	1.25	Oval	2.88	P921
	12.5	97F9080	A	1.25	Oval	4.75	P921
	15.0	97F9625	A	1.25	Oval	4.75	P921
	20.0	97F9630	P	1.75	Round	3.88	P965
	25.0	97F9632	P	1.75	Round	3.88	P965
	30.0	97F9635	P	1.75	Round	3.88	P965
	35.0	97F9639	S	2.00	Round	3.88	P968
	40.0	97F9642	S	2.00	Round	3.88	P968
	45.0	97F9645	S	2.00	Round	4.75	P968
	50.0	97F5211	T	2.50	Round	3.88	P969
	55.0	97F9042	T	2.50	Round	4.75	P969
	60.0	97F9043	T	2.50	Round	4.75	P969
	65.0	97F5241	T	2.50	Round	4.75	P969
	70.0	97F5251	T	2.50	Round	4.75	P969
	75.0	27L349	T	2.50	Round	5.25	P969
80.0	27L322	T	2.50	Round	5.25	P969	

Case Style P,S and T

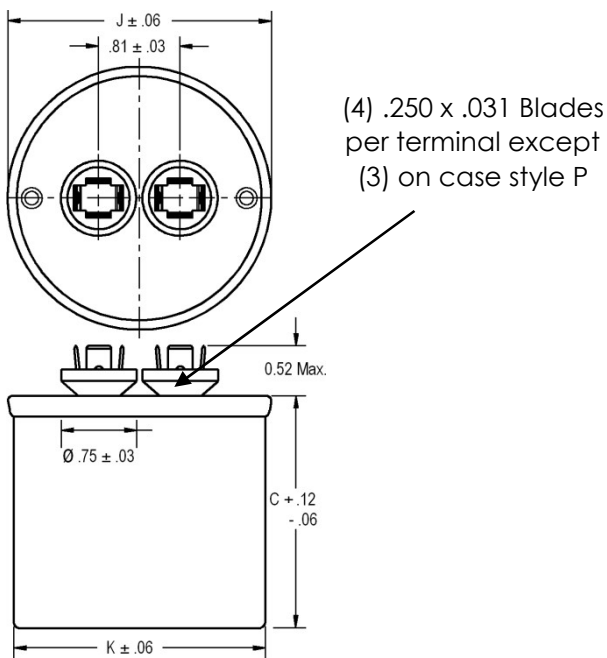

Case Style	K	J
P	1.75	1.88
S	2.00	2.12
T	2.50	2.62

Motor Run Capacitors – GEM III

Dual Ratings – 2 Sections

Voltage (VAC)	Capacitance		Catalog Number	Case Style	Base Size (in.)	Can Type	Height C (in.)	UL Code
	Herm (µF)	Fan (µF)						
370	10.0	10.0	27L956	C	1.75	Oval	2.12	P923
	15.0	5.0	97F9437	C	1.75	Oval	2.88	P923
	15.0	7.5	97F9526	C	1.75	Oval	2.88	P923
	15.0	10.0	97F9015	C	1.75	Oval	2.88	P923
	20.0	5.0	97F9673	C	1.75	Oval	2.88	P923
	20.0	7.5	97F9991	C	1.75	Oval	2.88	P923
	20.0	10.0	97F9018	C	1.75	Oval	3.88	P923
	25.0	5.0	97F9675	C	1.75	Oval	2.88	P923
	25.0	7.5	97F9677	C	1.75	Oval	2.88	P923
	25.0	10.0	97F9678	C	1.75	Oval	2.88	P923
	30.0	5.0	97F9681	C	1.75	Oval	3.88	P923
	30.0	7.5	97F9683	C	1.75	Oval	3.88	P923
	30.0	10.0	27L533	C	1.75	Oval	3.88	P923
	35.0	5.0	97F9796	C	1.75	Oval	3.88	P923
	35.0	7.5	97F9864	C	1.75	Oval	3.88	P923
	35.0	10.0	97F9888	C	1.75	Oval	3.88	P923
	40.0	5.0	97F9840	C	1.75	Oval	3.88	P923
	40.0	7.5	97F9845	C	1.75	Oval	3.88	P923
	40.0	10.0	97F9462	C	1.75	Oval	3.88	P923
	45.0	5.0	97F9859	C	1.75	Oval	3.88	P923
	45.0	7.5	97F9841	C	1.75	Oval	3.88	P923
	45.0	10.0	97F9758	C	1.75	Oval	3.88	P923
	50.0	5.0	97F9885	C	1.75	Oval	4.75	P923
	50.0	7.5	97F9858	C	1.75	Oval	4.75	P923
50.0	10.0	97F9030	D	2.00	Oval	4.75	P924	

Case Style C and D

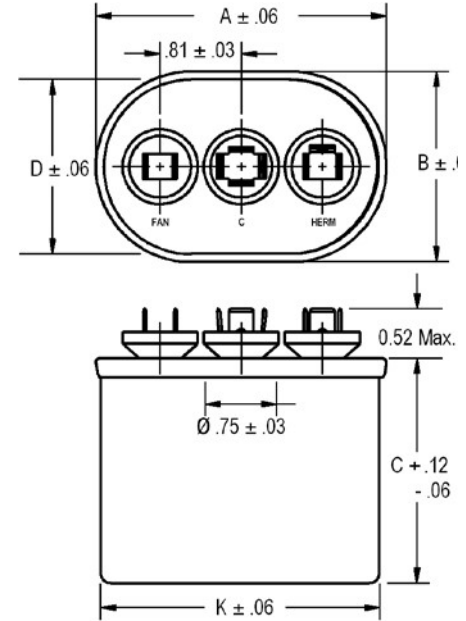

Case Style	A	B	D	K
C	2.91	1.91	1.81	2.81
D	3.66	1.97	1.88	3.56

Motor Run Capacitors – GEM III Dual Ratings – 2 Sections

Case Style C and D

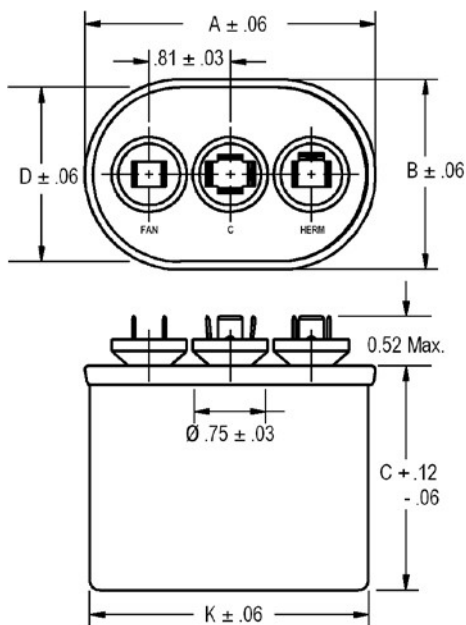

Voltage (VAC)	Capacitance		Catalog Number	Case Style	Base Size (in.)	Can Type	Height C (in.)	UL Code
	Herm (µF)	Fan (µF)						
440	15.0	5.0	97F9694	C	1.75	Oval	2.88	P923
	15.0	7.5	97F9992	C	1.75	Oval	2.88	P923
	15.0	10.0	97F9046	C	1.75	Oval	3.88	P923
	20.0	5.0	97F9695	C	1.75	Oval	2.88	P923
	20.0	7.5	97F9696	C	1.75	Oval	3.88	P923
	20.0	10.0	97F9048	C	1.75	Oval	3.88	P923
	25.0	5.0	97F9730	C	1.75	Oval	3.88	P923
	25.0	7.5	97F9993	C	1.75	Oval	3.88	P923
	25.0	10.0	97F9051	C	1.75	Oval	4.75	P923
	30.0	5.0	97F9994	C	1.75	Oval	3.88	P923
	30.0	7.5	97F9995	C	1.75	Oval	3.88	P923
	30.0	10.0	97F9054	C	1.75	Oval	4.75	P923
	35.0	5.0	97F9842	C	1.75	Oval	4.75	P923
	35.0	7.5	97F9892	C	1.75	Oval	4.75	P923
	35.0	10.0	97F9738	D	2.00	Oval	3.88	P924
	40.0	5.0	97F9843	C	1.75	Oval	4.75	P923
	40.0	7.5	97F9996	C	1.75	Oval	4.75	P923
	40.0	10.0	97F9780	D	2.00	Oval	4.75	P924
	45.0	5.0	97F9844	C	1.75	Oval	4.75	P923
	45.0	7.5	97F9760	D	2.00	Oval	4.75	P924
	45.0	10.0	97F9477	C	1.75	Oval	4.75	P923
	50.0	5.0	97F5729	D	2.00	Oval	5.25	P924
	50.0	7.5	97F5781	D	2.00	Oval	5.25	P924
	50.0	10.0	97F9593	D	2.00	Oval	5.25	P924

Case	A	B	D	K
C	2.91	1.91	1.81	2.81
D	3.66	1.97	1.88	3.56

Motor Run Capacitors – GEM III

Dual Ratings – 2 Concentric Sections



Voltage (VAC)	Capacitance		Catalog Number	Case Style	Base Size (in.)	Can Type	Height C (in.)	UL Code
	Herm (µF)	Fan (µF)						
370	15.0	5.0	97F9810	S	2.00	Round	2.88	P968
	15.0	7.5	97F9811	S	2.00	Round	2.88	P968
	15.0	10.0	97F9965	S	2.00	Round	2.88	P968
	20.0	5.0	97F9814	S	2.00	Round	2.88	P968
	20.0	7.5	97F9966	S	2.00	Round	2.88	P968
	20.0	10.0	97F9967	S	2.00	Round	2.88	P968
	25.0	5.0	97F9803	S	2.00	Round	2.88	P968
	25.0	7.5	97F9826	S	2.00	Round	2.88	P968
	25.0	10.0	97F9827	S	2.00	Round	3.88	P968
	30.0	5.0	27L877	S	2.00	Round	2.88	P968
	30.0	7.5	97F9868	S	2.00	Round	3.88	P968
	30.0	10.0	97F9828	S	2.00	Round	3.88	P968
	35.0	5.0	97F9834	S	2.00	Round	3.88	P968
	35.0	7.5	97F9829	S	2.00	Round	3.88	P968
	35.0	10.0	97F9830	S	2.00	Round	3.88	P968
	40.0	5.0	97F9849	S	2.00	Round	3.88	P968
	40.0	7.5	97F9855	S	2.00	Round	3.88	P968
	40.0	10.0	97F9831	S	2.00	Round	3.88	P968
	45.0	5.0	27L880	S	2.00	Round	3.88	P968
	45.0	7.5	27L947	S	2.00	Round	3.88	P968
	45.0	10.0	97F9832	S	2.00	Round	4.75	P968
	50.0	5.0	97F9970	S	2.00	Round	4.75	P968
	50.0	7.5	97F9971	S	2.00	Round	4.75	P968
	50.0	10.0	97F9972	S	2.00	Round	4.75	P968
	55.0	5.0	97F9815	T	2.50	Round	3.88	P969
	55.0	7.5	97F9973	T	2.50	Round	3.88	P969
	55.0	10.0	97F9974	T	2.50	Round	3.88	P969
	60.0	5.0	27L954	T	2.50	Round	3.88	P969
	60.0	7.5	97F9817	T	2.50	Round	4.75	P969
	60.0	10.0	27L389	T	2.50	Round	4.75	P969
70.0	5.0	27L633	T	2.50	Round	4.75	P969	
70.0	7.5	27L556	T	2.50	Round	4.75	P969	
70.0	10.0	27L414	T	2.50	Round	4.75	P969	
80.0	5.0	27L651	T	2.50	Round	4.75	P969	
80.0	7.5	27L522	T	2.50	Round	4.75	P969	
80.0	10.0	25L261	T	2.50	Round	4.75	P969	

Case Style S and T

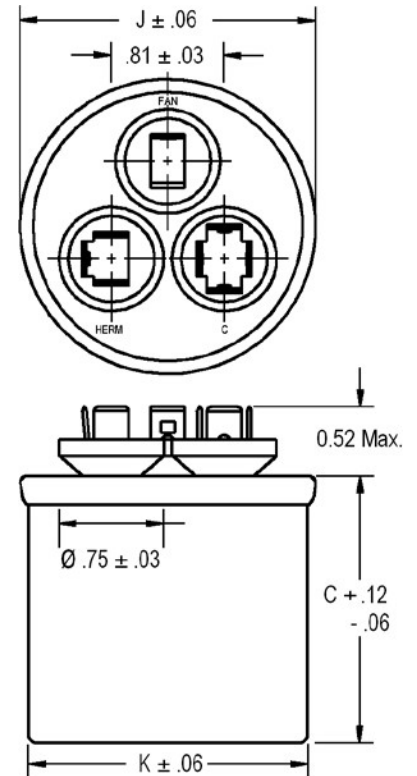

Case Style	K	J
S	2.00	2.12
T	2.50	2.62



Motor Run Capacitors – GEM III

Dual Ratings – 2 Concentric Sections



Case Style S and T

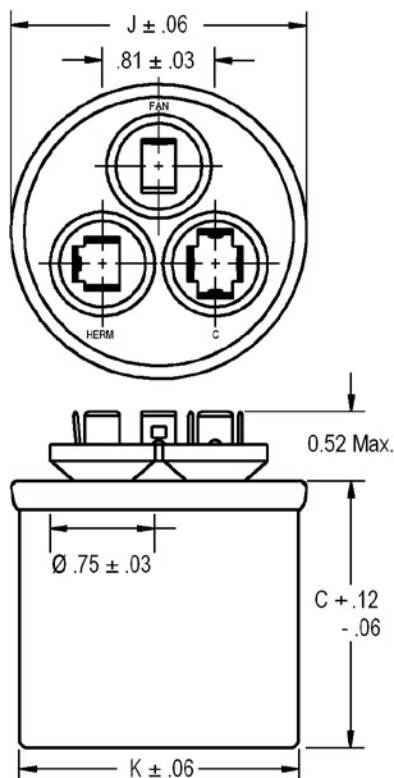

Case	K	J
S	2.00	2.12
T	2.50	2.62

Voltage (VAC)	Capacitance		Catalog Number	Case Style	Base Size (in.)	Can Type	Height C (in.)	UL Code
	Herm (µF)	Fan (µF)						
440	15.0	5.0	97F9997	S	2.00	Round	2.88	P968
	15.0	7.5	97F9998	S	2.00	Round	3.88	P968
	20.0	5.0	97F9975	S	2.00	Round	2.88	P968
	20.0	7.5	97F9976	S	2.00	Round	3.88	P968
	20.0	10.0	97F9451	T	2.50	Round	3.88	P969
	25.0	5.0	97F9978	S	2.00	Round	3.88	P968
	25.0	7.5	97F9979	S	2.00	Round	3.88	P968
	25.0	10.0	27L558	S	2.00	Round	3.88	P968
	30.0	5.0	97F9981	S	2.00	Round	3.88	P968
	30.0	7.5	97F9982	S	2.00	Round	3.88	P968
	30.0	10.0	97F9983	S	2.00	Round	3.88	P968
	35.0	5.0	97F9848	S	2.00	Round	4.75	P968
	35.0	7.5	97F9881	S	2.00	Round	4.75	P968
	35.0	10.0	27L204	T	2.50	Round	3.88	P969
	40.0	5.0	97F9838	S	2.00	Round	4.75	P968
	40.0	7.5	97F9882	S	2.00	Round	4.75	P968
	40.0	10.0	97F9985	S	2.00	Round	4.75	P968
	45.0	5.0	27L889	S	2.00	Round	4.75	P968
	45.0	7.5	97F9883	T	2.50	Round	3.88	P969
	45.0	10.0	27L378	T	2.50	Round	3.88	P969
	50.0	5.0	27L569	T	2.50	Round	4.25	P969
	50.0	7.5	97F9987	T	2.50	Round	4.75	P969
	50.0	10.0	27L647	T	2.50	Round	4.75	P969
	55.0	5.0	97F9839	T	2.50	Round	4.75	P969
	55.0	7.5	97F9874	T	2.50	Round	4.75	P969
	55.0	10.0	97F9989	T	2.50	Round	4.75	P969
	60.0	5.0	97F9897	T	2.50	Round	4.75	P969
	60.0	7.5	97F9898	T	2.50	Round	4.75	P969
	60.0	10.0	25L756	T	2.50	Round	4.75	P969
	70.0	10.0	27L866	T	2.50	Round	4.75	P969
80.0	7.5	27L801	T	2.50	Round	4.75	P969	



LIFE vs TEMPERATURE CHART M-1

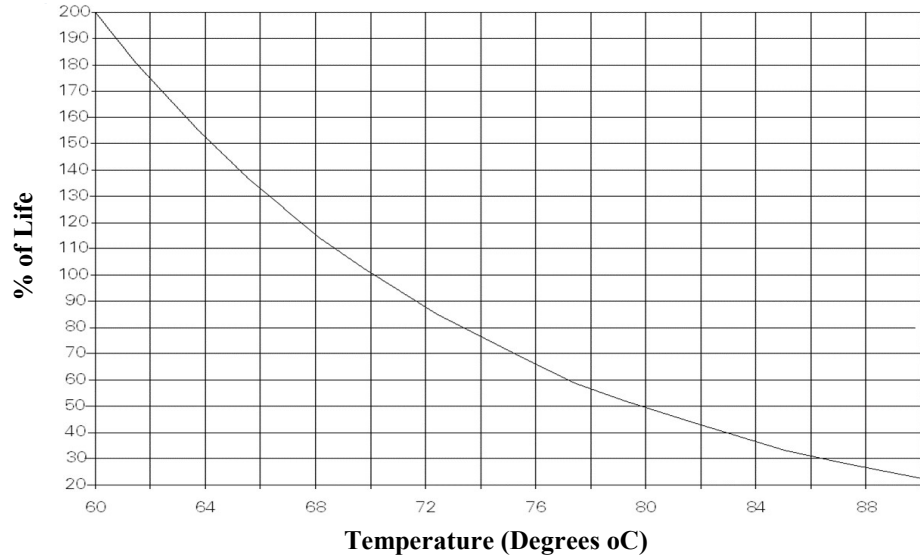

LIFE vs VOLTAGE CHART M-2

This chart is intended as general reference only. Any indication of extended life by reducing voltage is in no way a guarantee of extended product life.

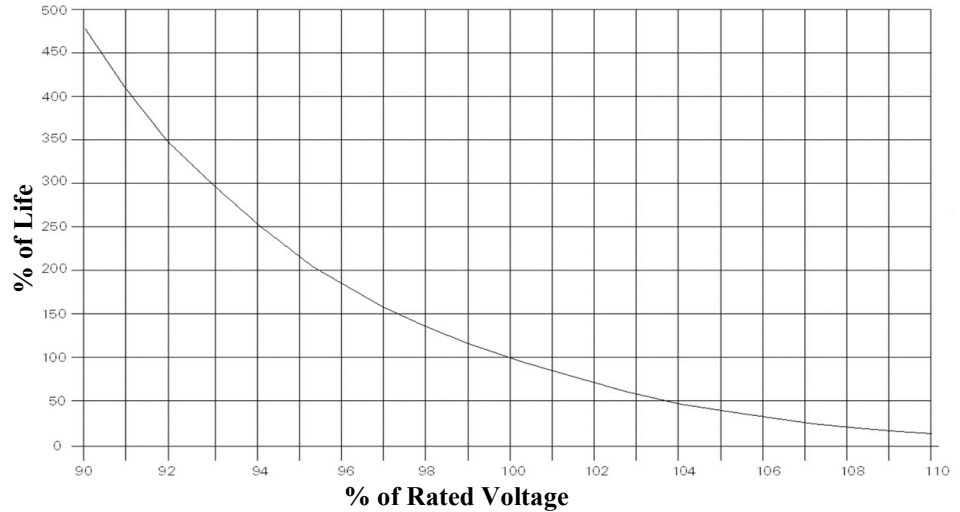

% CAPACITANCE vs. TEMPERATURE CHART M-3

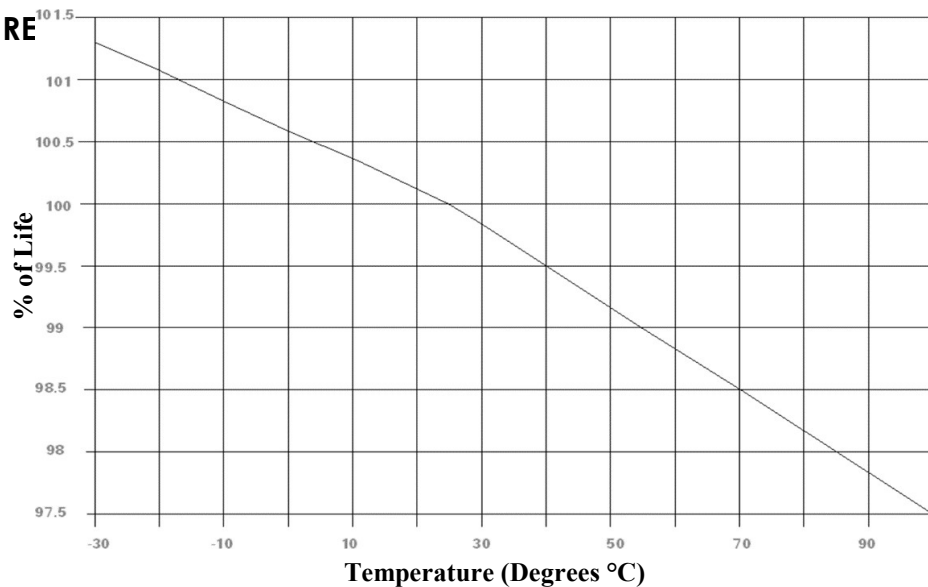

Round Case Style P,S,T

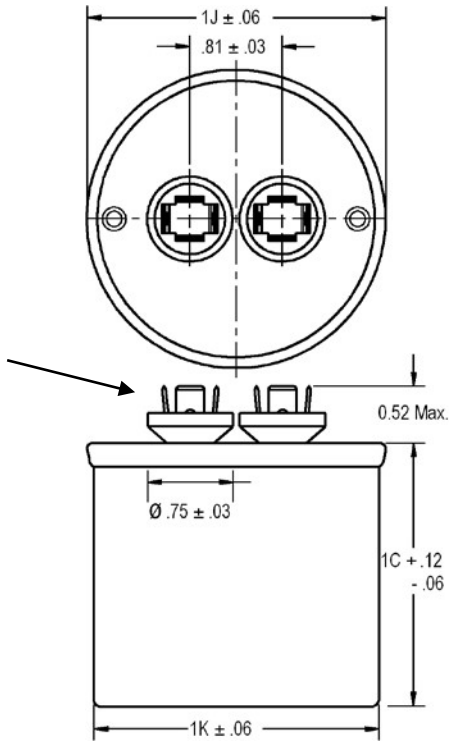

Oval Case Style A,B,C,D

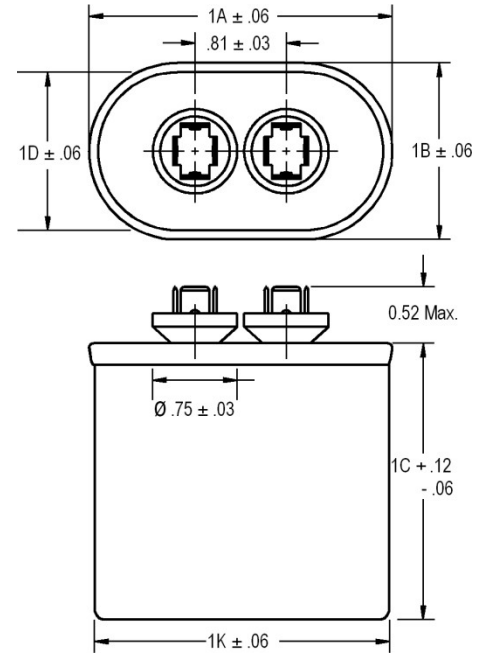

Oval Case Style		Dimensions			
		1A	1B	1D	1K
A	Oval	2.16	1.31	1.21	2.06
B	Oval	2.69	1.56	1.47	2.58
C	Oval	2.91	1.91	1.81	2.81
D	Oval	3.66	1.97	1.88	3.56
C	Dual Oval	2.91	1.91	1.81	2.81
D	Dual Oval	3.66	1.97	1.88	3.56

Round Case Style		Dimensions			
		1K			1J
P	Round	1.75	----	----	1.88
S	Round	2.00	----	----	2.12
T	Round	2.50	----	----	2.62

Dual Oval Case Style C,D

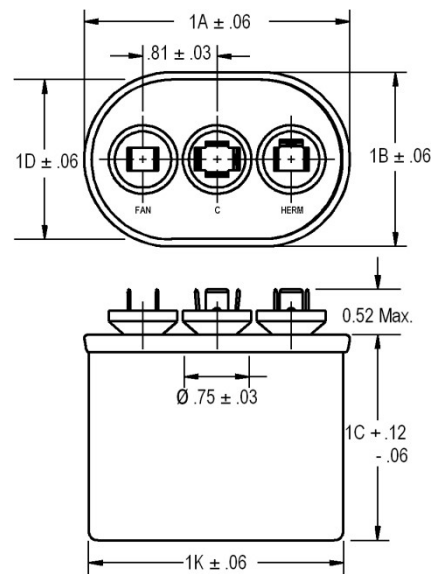

Capacitor Label

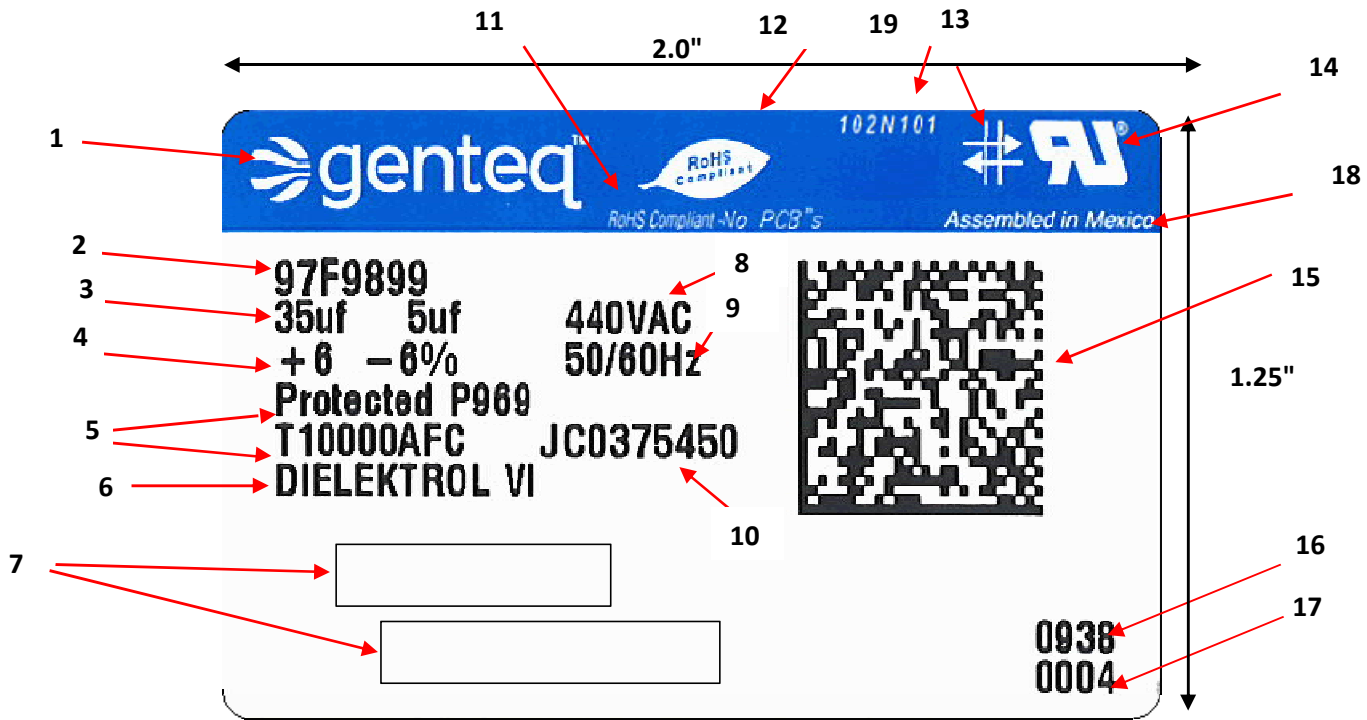

- 1. Product / Brand
- 2. Genteq Catalog Model Number
- 3. Capacitance in Micro-Farads
- 4. Tolerance
- 5. UL Designation Including Available Fault Current (AFC) Rating
- 6. Genteq Product Name of Dielectric Fluid
- 7. Customer Part Number and Bar Code
- 8. AC Voltage Rating
- 9. Frequency
- 10. Manufacturing WIP Job Number
- 11. RoHS Compliant / No PCBs Statement
- 12. RoHS Compliant Logo
- 13. Self-Healing Symbol
- 14. UL Approved Logo

- 15. Data Matrix Bar Code
- 16. Manufacturing Date Code

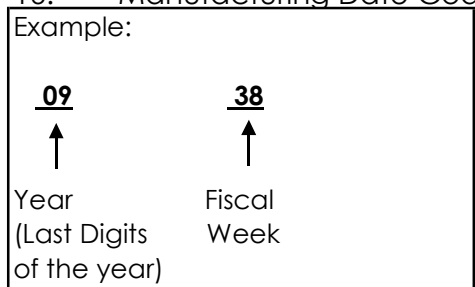

- 17. Label Sequence Number
- 18. Country of Origin
- 19. Label Part Number (Internal)



Capacitors



Ampere 8755,
Parque Industrial Antonio J. Bermúdez,
Cd. Juárez, Chihuahua, CP 32470
MEXICO
Tel: +52 (656) 649 64 00
www.capcom.mx