

Radial Leaded PTC

OZRE Series

HF **Pb** OZRE Series Fuse

RoHS 6 Compliant & Halogen-Free

Application

Line Voltage Power Supply, Transformer and Appliances

Product Features

Continuous Use at voltages up to 240V AC/DC, Low Hold Current, 265V AC/DC Max Interrupt voltage

Operating (Hold Current) Range

50mA - 550mA

Temperature Range

-40°C to 85°C

Maximum Operating Voltage

240V AC/DC

Maximum Interrupt Voltage

265V AC/DC

Agency Approval

TUV (Std. EN60738-1-1, Cert. R50102173)

UL Component (Std. UL1434, File E305051)

UL Conditions of Acceptability:

1. These devices have been investigated for use in safety circuits and are suitable as a limiting device.
2. These devices have been calibrated to limit the current to 8 amps within 5 seconds, per ANSI/NFPA 70, "National Electrical Code".

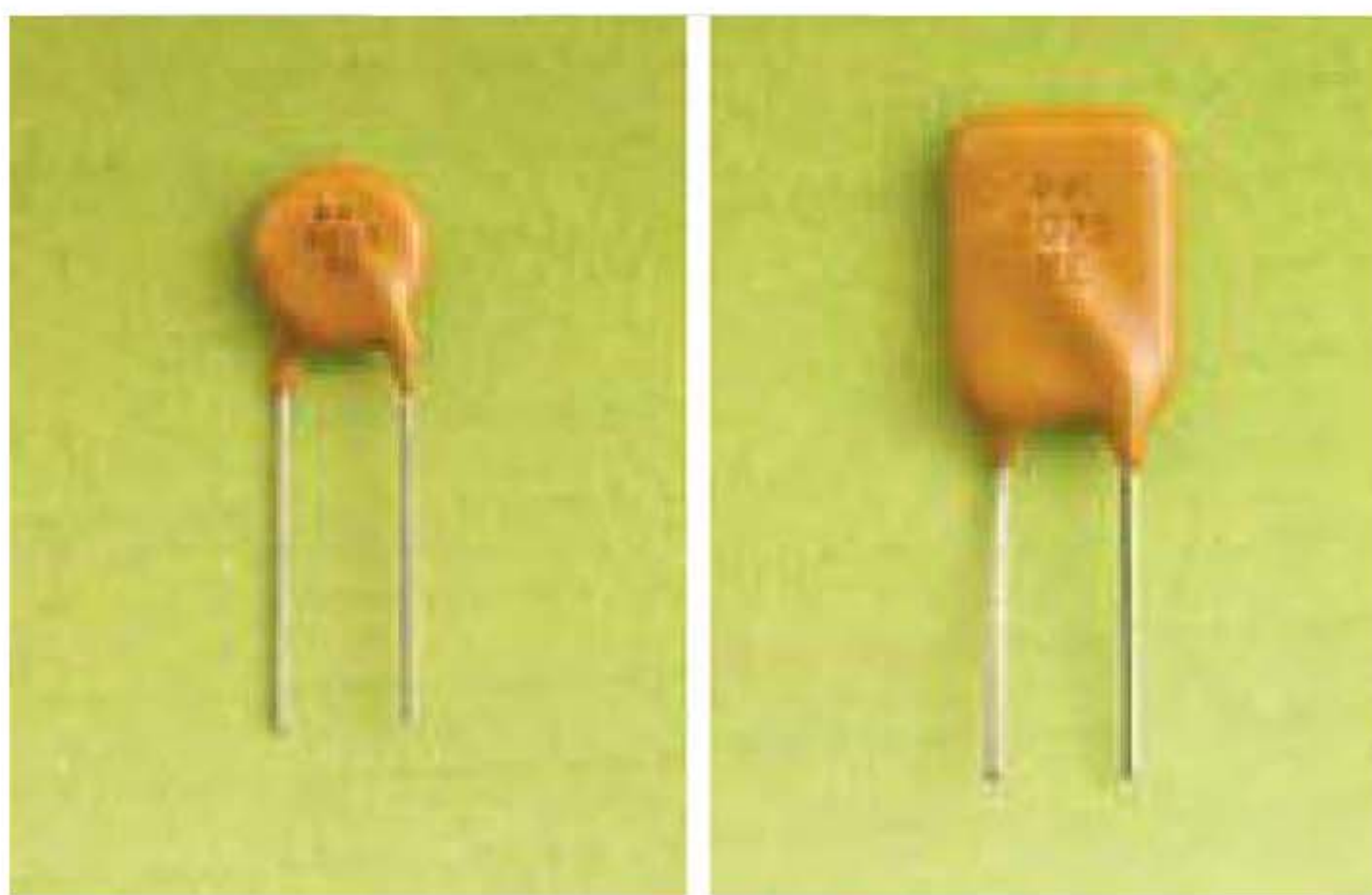

LEAD FREE = **Pb**

HALOGEN FREE = **HF**

Electrical Characteristics (23°C)

	Part Number (Bulk)	Hold Current	Trip Current	Max Time to Trip @ 5xIH	Max Current	Rated Voltage	Typical Power	Resistance Tolerance			Agency Approvals	
								Rmin	Rmax	R1max	c UL us	TUV
								Ohms	Ohms	Ohms		
A	OZRE0005FF1C	0.05	0.12	15.0	1.5	240	0.7	18.50	31.00	65.00	Y	Y
B	OZRE0008FF1C	0.08	0.19	15.0	1.5	240	0.8	7.40	12.00	26.00	Y	Y
C	OZRE0012FF1C	0.12	0.30	15.0	2.0	240	1.0	3.00	6.50	12.00	Y	Y
D	OZRE0016FF1C	0.16	0.37	15.0	2.0	240	1.4	2.50	4.10	7.80	Y	Y
E	OZRE0025FF1E	0.25	0.56	18.5	6.0	240	1.5	1.30	2.10	3.80	Y	Y
F	OZRE0033FF1A	0.33	0.74	21.0	6.0	240	1.7	0.83	1.24	2.60	Y	Y
G	OZRE0040FF1A	0.40	0.90	24.0	7.0	240	2.0	0.60	0.97	1.90	Y	Y
H	OZRE0055FF1A	0.55	1.25	26.0	7.0	240	3.4	0.45	0.73	1.45	Y	Y

- IH Hold Current-maximum current at which the device will not trip in still air at 23°C.
- IT Trip current-minimum current at which the device will always trip in still air at 23°C.
- I_{max} Maximum fault current device can withstand without damage at rated voltage (V_{max}).
- V_{max} Maximum voltage device can withstand without damage at its rated current.
- P_d Typical power dissipated by device when in tripped state in 23°C still air environment.
- R_{min} Minimum device resistance at 23°C.
- R_{max} Maximum device resistance at 23°C.
- R_{1max} Maximum device resistance at 23°C, 1 hour after initial device trip, or after being soldered to PCB in end application.

Specifications subject to change without notice



Bel Fuse Inc.
206 Van Vorst Street
Jersey City, NJ 07302 USA

+1 201.432.0463
techhelp@belf.com
belfuse.com

Radial Leaded PTC

OZRE Series

HF  OZRE Series Fuse

RoHS 6 Compliant & Halogen-Free

PTC's - Basic Theory of Operation / "Tripped" Resistance Explanation

Fundamentally, a Bel PTC consists of a block of polymeric material containing conductive filler and bonded between two conductive, planar terminations.

At currents below the device I_{HOLD} rating, AND at temperatures below 100C, the PTC maintains a resistance value below its R₁ MAX rating.

As the device's temperature approaches 130C, either due to an increase in ambient temperature or a current exceeding its I_{TRIP} rating, volumetric expansion of the filled polymer breaks apart the majority of conductive pathways across the terminals created by chain contact of adjacent filler particles or device resistance increases sharply by several orders of magnitude.

At the much higher "Tripped" resistance, there is just enough leakage current to allow internal heating to "hold" the device in its tripped state (around 125C) until power is interrupted. Once power is removed, the PTC's core cools and contracts allowing conductive chains to reform and return the device to its low resistance state.

The catalog data for each device specifies a "Typical Power" value. This is the power required to exactly match the heat lost by the tripped device to its ambient surroundings at 23C. By Ohm's Law, power can be stated as: $W = E^2/R$. Thus the approximate resistance of a "Tripped" PTC can be determined by: $R = E^2/W$, where "E" is the voltage appearing across the PTC (usually the supply's open circuit voltage), and "W" is the Typical Power value for the particular PTC. Since the PPTC acts to maintain a constant internal temperature, its apparent resistance will change based upon applied voltage and, to a lesser degree, ambient conditions. Consider the following example....

A PTC with a Typical Power of 1 watt protecting a circuit using a 60V supply will demonstrate an apparent, tripped resistance "R" of:

$$R = 60^2/1 = 3,600 \text{ ohms}$$

This same tripped device when used to protect a 12V circuit would now present an apparent resistance of:

$$R = 12^2/1 = 144 \text{ ohms}$$

The value for Typical Power is "typical" because any physical factors that affect heat loss (such as ambient temperature or air convection) will somewhat alter the level of power that the PTC needs to maintain its internal temperature. In short, PTCs do not exhibit a constant, quantifiable tripped resistance value.

Type Time - To - Trip at 23°C

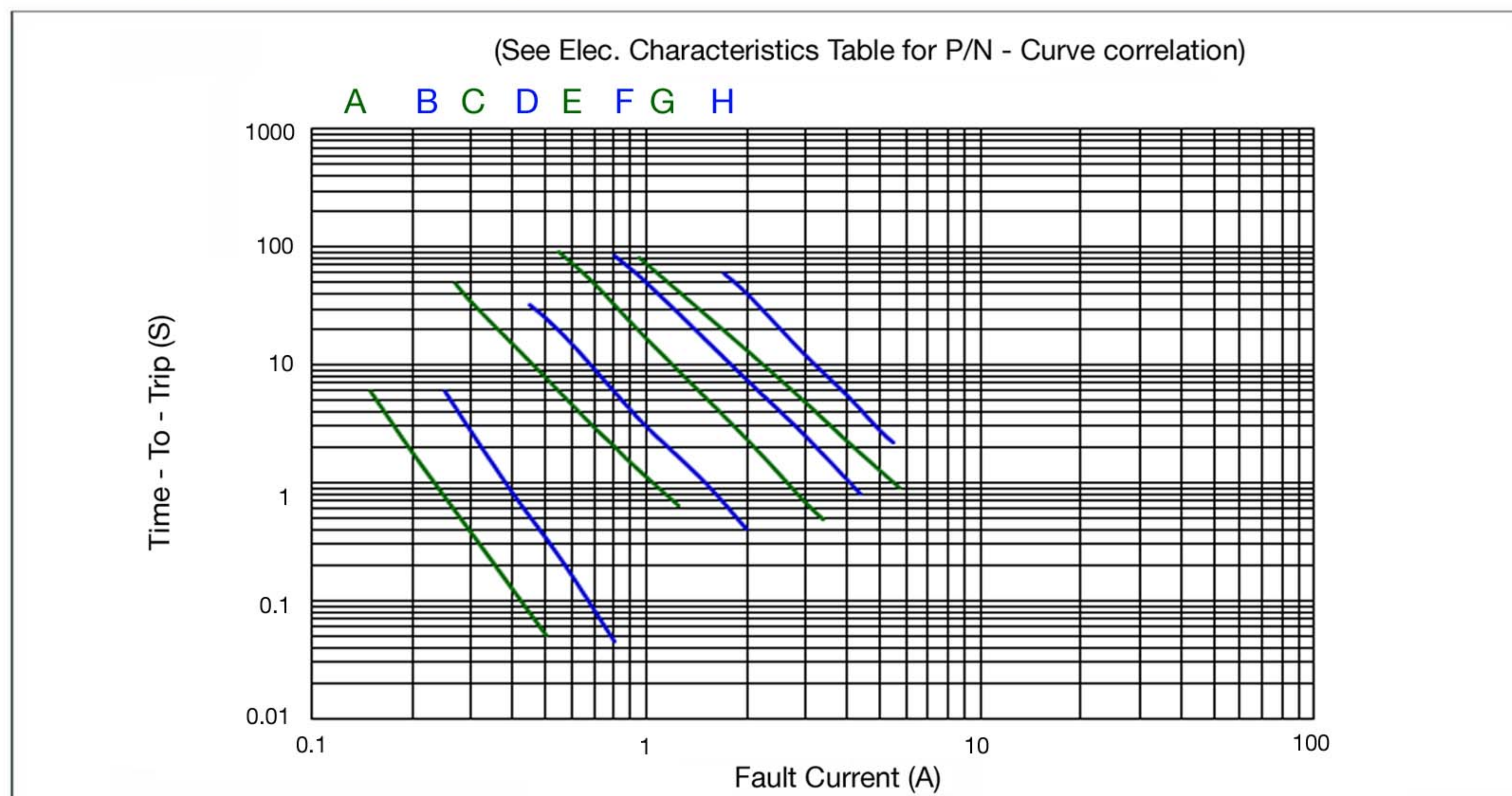

Specifications subject to change without notice



Bel Fuse Inc.
206 Van Vorst Street
Jersey City, NJ 07302 USA

+1 201.432.0463
techhelp@belf.com
belfuse.com

Radial Leaded PTC

OZRE Series

HF  OZRE Series Fuse

RoHS 6 Compliant & Halogen-Free

Physical Specifications

Lead material:

Matte tin plated copper, size / diameter as shown in Drawings and Table under Product Dimensions.

Soldering characteristics

MIL-STD-202, Method 208H.

Insulating coating

Flame retardant epoxy, meets UL-94-V-0 requirements.

PTC Marking

“bel” or “b”, , IH code and “RE” .

Product Dimensions

All dimensions in mm.

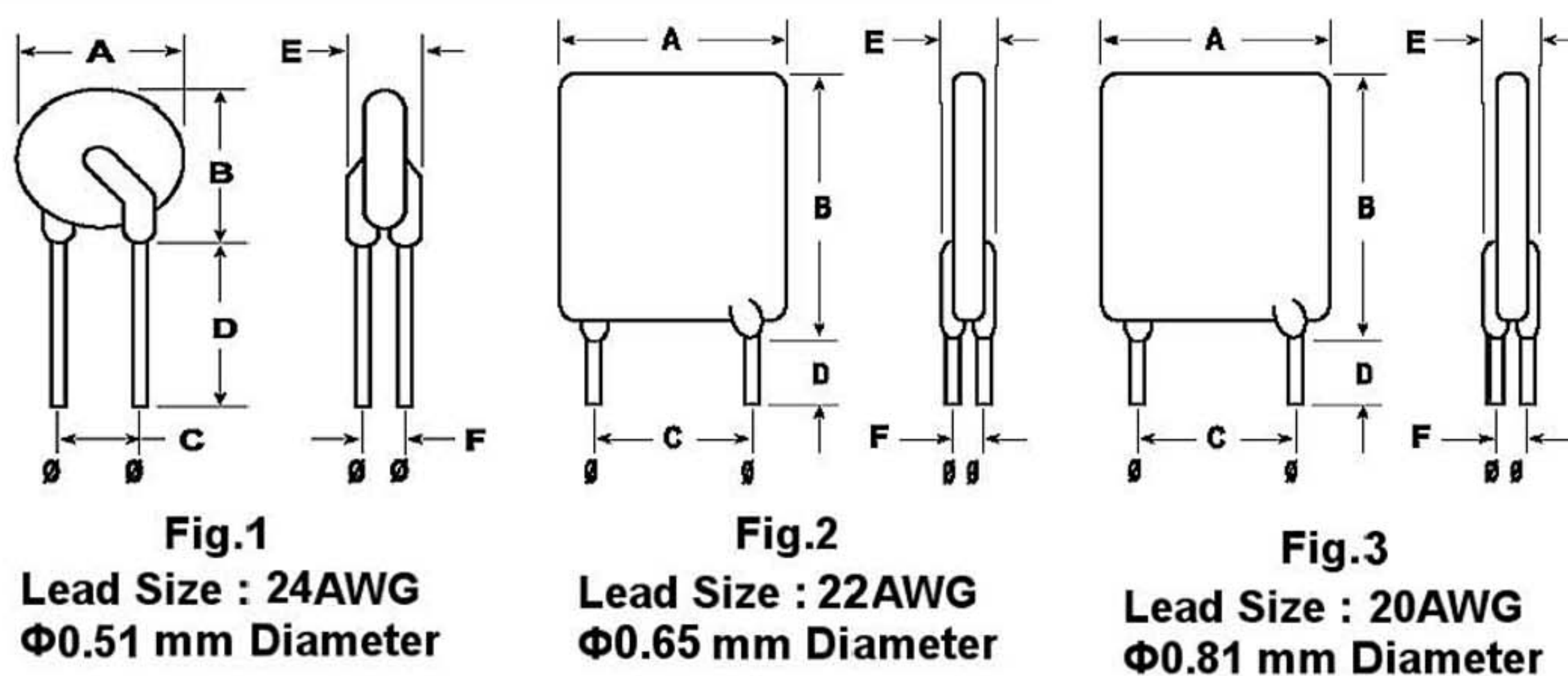

Part Number	Fig.	A	B	C	D	E	F
		Max	Max	Typical	Min	Max	Typical
OZRE0005FF to OZRE0012FF	1	8.3	10.7	5.1	7.6	3.8	1.6
OZRE0016FF	1	9.9	12.5	5.1	7.6	3.8	1.6
OZRE0025FF	2	9.6	17.4	5.1	7.6	3.8	1.8
OZRE0033FF	2	11.4	16.5	5.1	7.6	3.8	1.8
OZRE0040FF	2	11.5	19.5	5.1	7.6	3.8	1.8
OZRE0055FF	3	14.0	21.7	5.1	7.6	4.1	1.9

Thermal Derating Curve

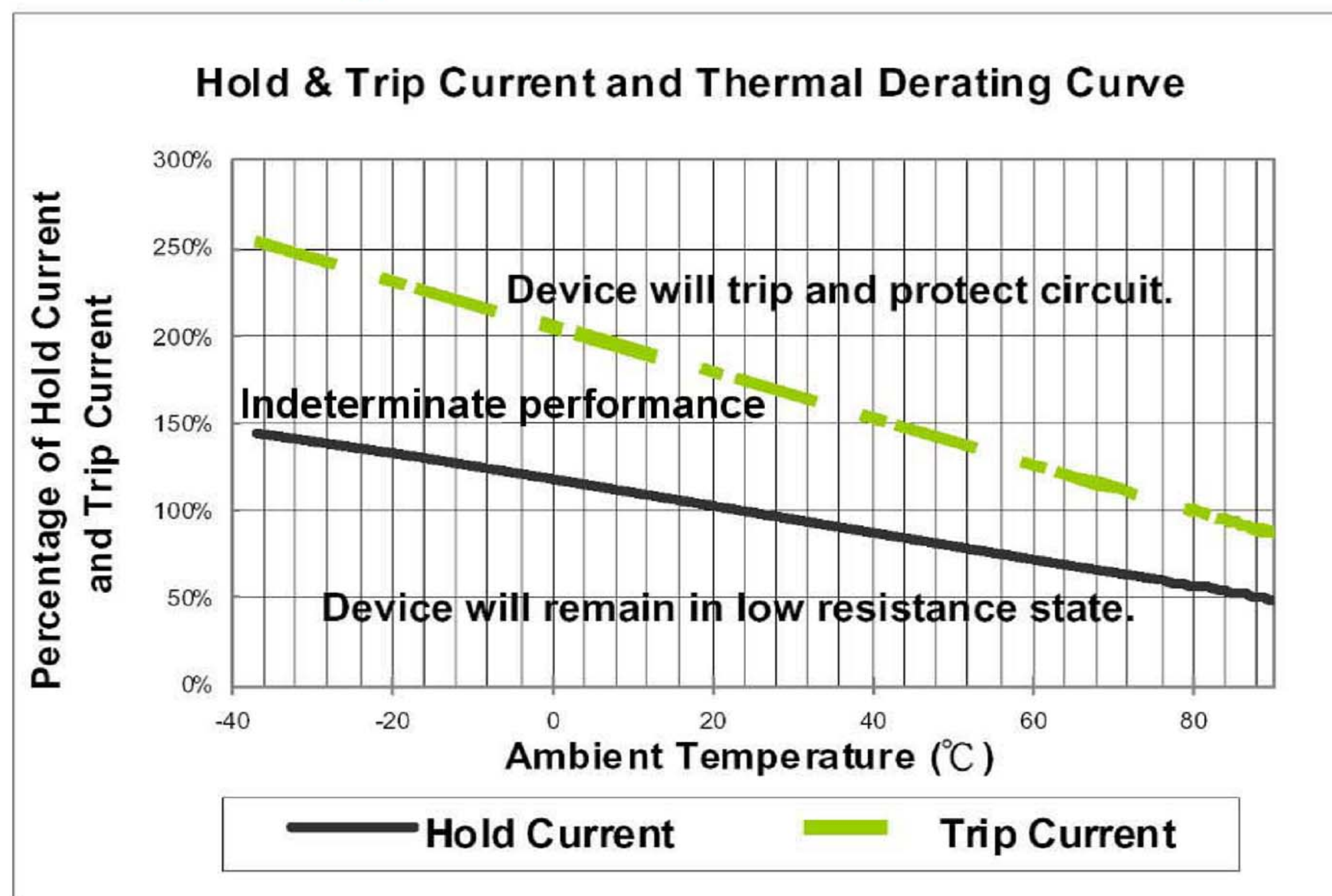

Cautionary Notes

1. Operation beyond the specified maximum ratings or improper use may result in damage and possible electrical arcing and/or flame.
2. These Polymer PTC (PPTC) devices are intended for protection against occasional overcurrent/ overtemperature fault conditions and may not be suitable for use in applications where repeated and/or prolonged fault conditions are anticipated.
3. Avoid contact of PTC device with chemical solvent. Prolonged contact may adversely impact the PTC performance.
4. These PTC devices may not be suitable for use in circuits with a large inductance, as the PTC trip can generate circuit voltage spikes above the PTC rated voltage.
5. These devices are intended for use in DC voltage applications only. Use in AC voltage applications should be first discussed with Bel Fuse engineering.
6. Not recommended for use on potted or conformal coated PCB's. Restriction of free air flow could affect electrical performance and/or result in device failure. Consult Bel Fuse engineering.
7. In the "Indeterminate Performance / grey zone", tripping may occur but cannot be relied upon. For special circumstances considering use within this region, consult Bel Fuse Engineering.

Specifications subject to change without notice



Bel Fuse Inc.
206 Van Vorst Street
Jersey City, NJ 07302 USA

+1 201.432.0463
techhelp@belf.com
belfuse.com

Radial Leaded PTC

OZRE Series

HF  OZRE Series Fuse

RoHS 6 Compliant & Halogen-Free

Soldering Parameters

Lead-free Wave Soldering Profile	
Wave Solder Parameter	
Average ramp-up rate	200°C / second
Heating rate during preheat	typical 1 - 2°C / second Max 4°C / second
Final preheat temperature	within 125°C of soldering temperature
Peak temperature T _p	260°C
Time within +0°C / -5°C of actual peak temperature	5 seconds
Ramp-down rate	5°C / second max.

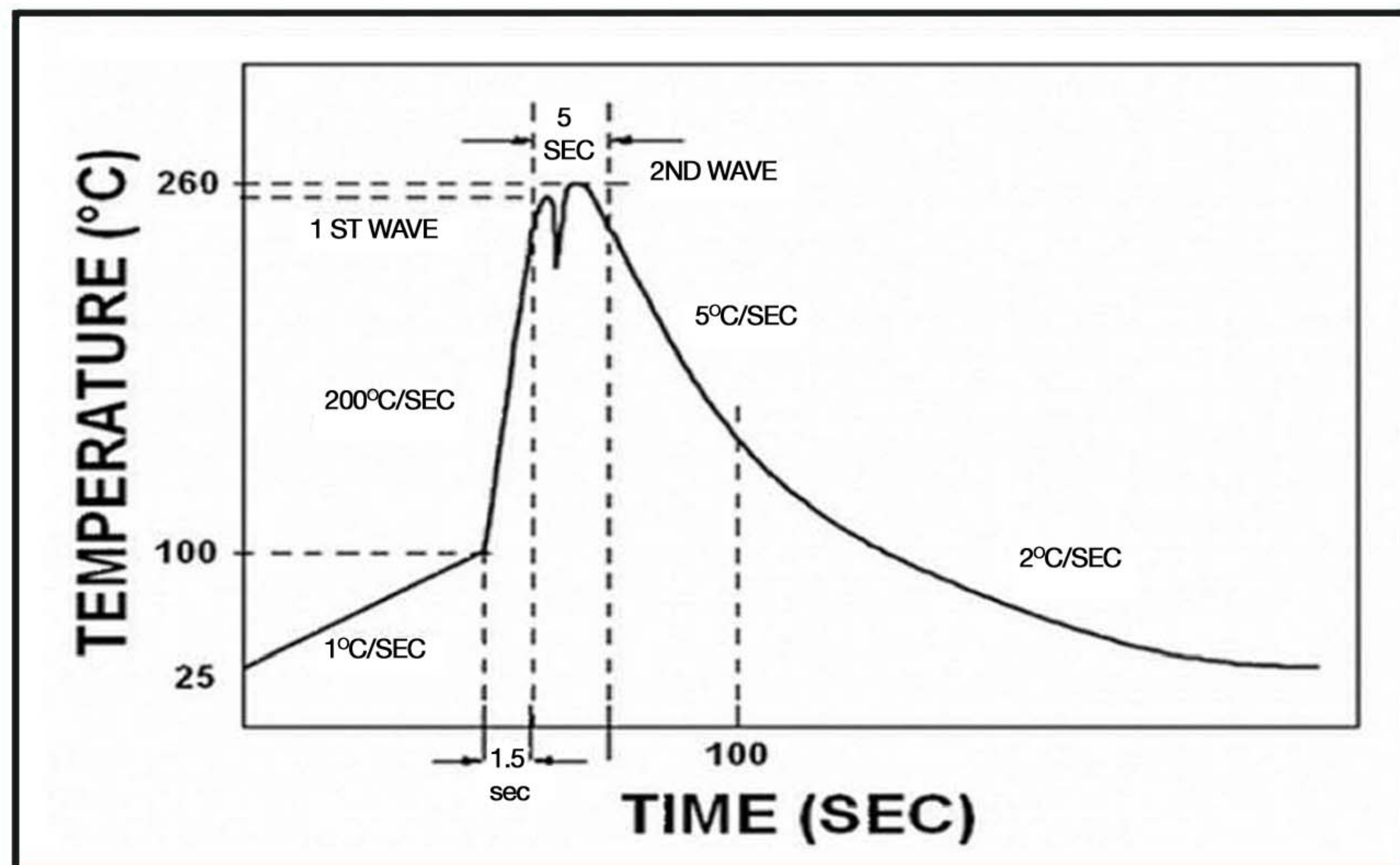

Standard Packaging

P/N	Bulk		Reel/Tape	
	Pcs/Box	P/N Code	Pcs/Reel	P/N Code
OZRE0005FF	2000	1C	2000	2C
-				
OZRE0016FF	3000	1E	1500	2B
OZRE0025FF	1000	1A	1500	2B
-				
OZRE0033FF	1000	1A	1000	2A
OZRE0040FF				
OZRE0055FF				

P/N Explanation and Ordering Information

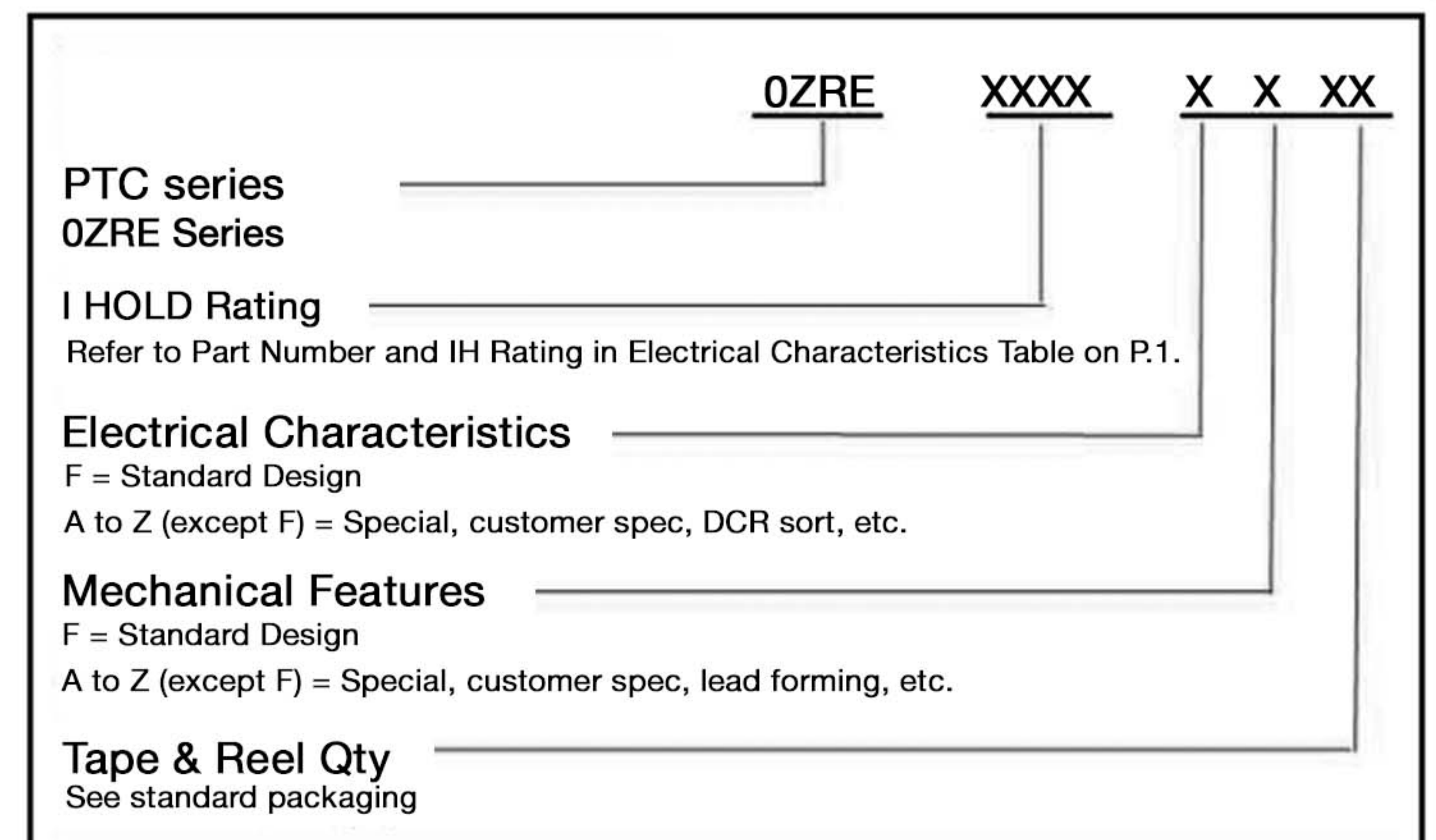

Specifications subject to change without notice



Bel Fuse Inc.
206 Van Vorst Street
Jersey City, NJ 07302 USA

+1 201.432.0463
techhelp@belf.com
belfuse.com