

LT series

Panel mount miniature trackball

Distinctive features and specifications



- Solid state sensing technology – laser tracking engine
- IP68 sealing
- Output: USB, PS/2 or SUN Systems
- Smooth operation in rugged environments
- Multiple top plate configurations
- Custom connector options

MECHANICAL

- Weight: ~15 g (0.53oz)
- Ball: Ø12.7mm (0.5")
- Ball Material: Phenolic, polyester, epoxy resin
- Tracking Force: 10 g (0.35oz) nominal – Damper ring
10-30 g (0.35-1.06oz) – Silicone rubber seal
- Ball Load: 50N (5Kg) maximum downward pressure for 2 minutes @ 20°C (68°F)
- Resolvable Ball Speed: 30 IPS (inches per second)
- Mounting Position: All angles
- Tracking Engine: Laser navigation technology
- Top Plate Material: PC/ABS – Black
- Sealing Gasket: Silicone seal (DC7091 black)
- Vibration: 2g (0.18oz), 10-500Hz, 1 octave/min, 10 sweep cycles (IEC 60068-2-6)
- Operating Shock: 15g (0.53oz)/11ms, ½ sine, 3 shocks in +ve and -ve direction, all 3 axis (IEC 60068-2-27)
- Mechanical Lifetime: 1 million ball revolutions
- MTBF: In excess of 100,000 hours (MIL-STD-217F)

PROTOCOL OPTIONS AND ELECTRICAL SPECIFICATIONS

- Protocol: USB, PS/2 or SUN Systems
- Supply Voltage: 4.4V to 5.25VDC
- Resolution: – 300 counts per ball revolution @ 1IPS (inches per second) ± 10%
– 600 counts per ball revolution @ 5IPS (inches per second) ± 10%
- Output Connector: 8 way, right-angled JST film connector
- Mating Output Connector: Flexible flat cable (FFC), 1.0mm pitch
- Laser Safety Class: Embedded class 1M laser safety, IEC 60825-1
- ESD: 15kV air-discharge and 8kV contact discharge (IES 60068-4-2)
- EMC: Radiated immunity – limits according to lever 3 of IEC 61000-4-3
Radiated emissions to EN55022 class B

ENVIRONMENTAL

- Operating Temperature: 0°C to +55°C (32°F to +131°F) (IEC 60068-2-1, IEC 60068-2-2)
- Storage Temperature: -40°C to +85°C (-40°F to +185°F) (IEC 60068-2-1, IEC 60068-2-2)
- Operating Humidity: 93% RH @ 40°C, non-condensing (IEC 60068-2-78)
- Storage Humidity: 10%-95% non-condensing (IEC 60068-2-78)
- Sealing Capability: IP68 (BS EN 60529)

NOTE: All values are nominal.

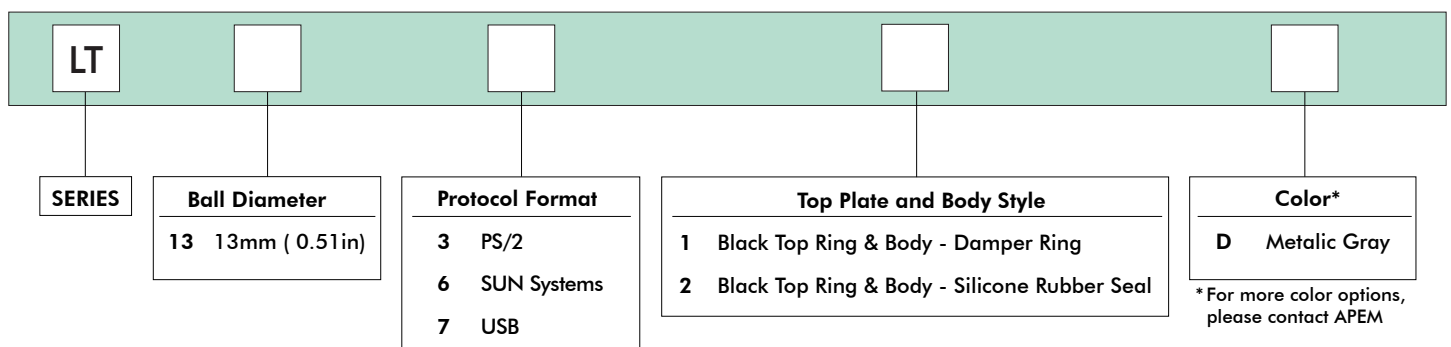

LT series

Panel mount miniature trackball

Overview

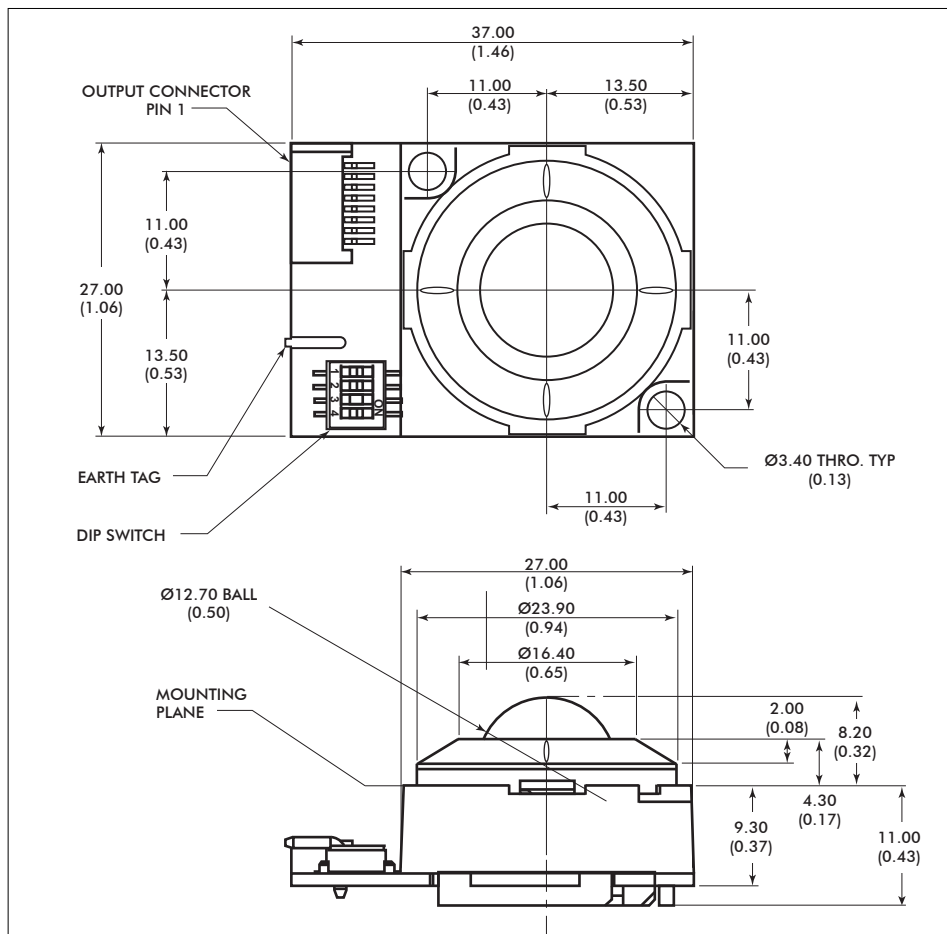

MOUNTING CUT-OUT DIMENSIONS

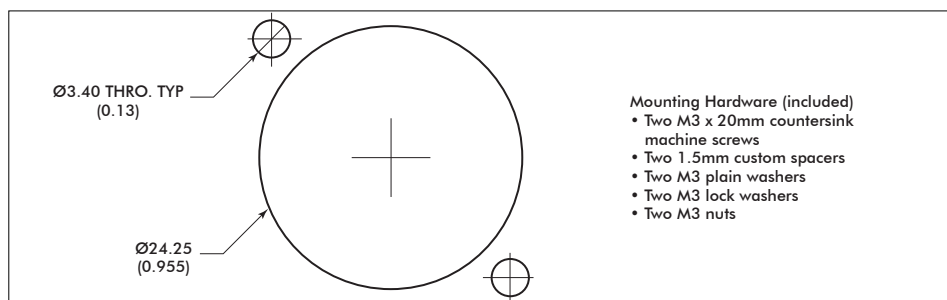

NOTES:

- Dimensions are in mm/(in).
- Dimensional drawing specifies factory default orientation.
- Tolerances ± 0.2 mm unless otherwise stated.
- Please note that an IGES model is available on request. Please contact factory for more information.

Note: The company reserves the right to change specifications without notice.

LT series

Panel mount miniature trackball

Overview

Connection is made to the LT series trackball by means of a single 8-way, right-angled, JST film connector (or equivalent). The table below highlights the connection details. Contact APEM for custom connections.

OUTPUT CONNECTOR

Description: Header 8 way 1.0mm pitch
Part Number: 08FM-1.0SP-1.9TF

Manufacturer: JST (or equivalent)
Mating Connector: Flexible flat cable (FFC), 1.0mm pitch

PIN NUMBER	USB / PS/2	SUN SYSTEMS
1	+5VDC	+5VDC
2	D-, PS/2 data	Data
3	D+, PS/2 clock	Do not connect
4	Right switch	Right switch
5	Left switch	Left switch
6	0V	0V
7	Middle switch	Middle switch
8	N.C.	N.C.

TRACKBALL CONFIGURATION

The LT series trackball provides features that may be selected using the DIP switch located on the printed circuit board. The table below details the assigned function of each switch.

DIP Switch Functions

DIP SWITCH*	FUNCTION	OFF	ON
1	Orientation 1 Setting	See Figure	See Figure
2	Orientation 2 Setting	See Figure	See Figure
3	Tracking Mode	Ballistic Tracking	Linear Tracking
4	Factory Setting	Switch must be set in OFF position	

*Factory default setting: All DIP switches OFF

ORIENTATION

The orientation function allows the user to mount the LT series trackball device in one of four positions as seen in the illustration below. The orientation of the device is determined by the direction in which the output connector is facing (when viewed from the top of trackball device). The trackball device orientation can be selected to accommodate customer requirements for connector location and wiring.

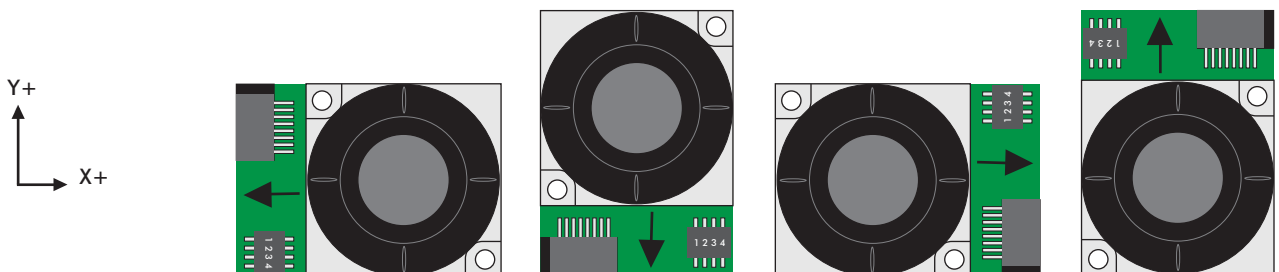

SWITCH 1 (ORIENTATION 1)	OFF	ON	OFF	ON
SWITCH 2 (ORIENTATION 2)	OFF	OFF	ON	ON

TRACKING MODE

Ballistic Tracking: Intuitive tracking algorithm to provide increased cursor resolution at maximum speeds, while retaining the original resolution for tracking accurately at slow speeds.

Linear Tracking: No tracking algorithm. 300 counts per ball revolution maintained at all tracking speeds.