

SF2-N SERIES

New

Small Light Curtain Type 2



Delivering global standard safety
Type 2
Series connection type

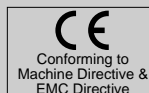

Application of IEC 61496 (Type 2) industrial standard

The **SF2-N** series have the same level of safety built into the sensor body as conventional fail-safe type area sensors, and conform European and North American safety standards. So, they can be used in workplaces throughout the world.

Europe

CE marking based on Machine Directive and EMC Directive has been obtained, so that the sensors can be used in Control Category 2 equipment.

[Type 2 based on IEC 61496-1/2, EN 61496-1] and Control Category 2 based on EN 954-1]

North America

C-UL US listings (UL 61496-1/2) which are required for use in the United States and Canada have been obtained.

Wire-saving by series connection

Using the optional serial connection cable, a maximum of 3 sets of sensors with a total of 128 beam channels (for 20 mm 0.787 in beam pitch type) or 64 beam channels (for 40 mm 1.575 in beam pitch type) can be connected in series. Hence, even L-shaped and U-shaped areas can be easily covered. Previously, separate wiring was required for 3 sets of sensors. But now, wiring equivalent to that for only one set is required, thus saving troublesome wiring and costs.



High level of safety achieved

The sensor carries out self-diagnosis when it is turned ON.

The monitoring section (CPU) which is inside the emitter constantly checks the emitting circuit and the control circuit. Furthermore, the receiver also has a monitoring section (CPU) which constantly checks the receiving circuit, control circuit and output circuit, so that a high level of safety is maintained at all times.

Safety design of the SF2-N series

- The sensor switches to the lockout mode when an error occurs, so that the OSSD (control output) and alarm output turn OFF.
- Two output transistors are connected in series to provide duality, so that the sensor also locks out if one of the transistors is short-circuited.
- Self-diagnosis using test input allows detailed checking such as overlapping emission (overcurrent error), light emission strength, etc.

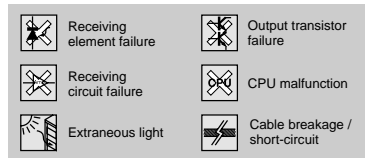
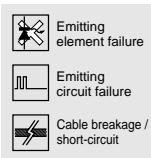
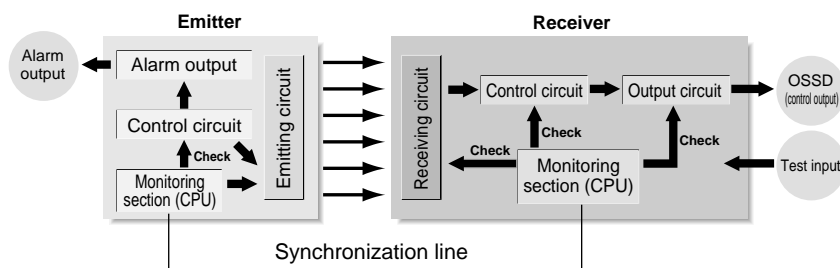

Compact design, 28 mm 1.102 in width and 19 mm 0.748 in thickness

The design is compact, with a width of only 28 mm 1.102 in and a thickness of 19 mm 0.748 in. The small amount of space needed allows the sensors to be incorporated into the machinery.

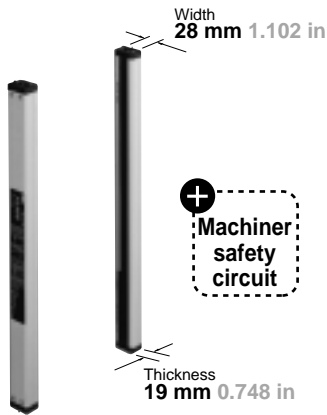

Convenient indicators allow easy beam alignment

The beam-axis alignment indicators are distributed on the sensors in four sections. The indicators of the sections whose beams are aligned light up in red, and when all beams are aligned, the indicators light up in green. The beam-axis alignment indicators are provided on both the emitter and the receiver, so that you can see at a glance which beams are not aligned.

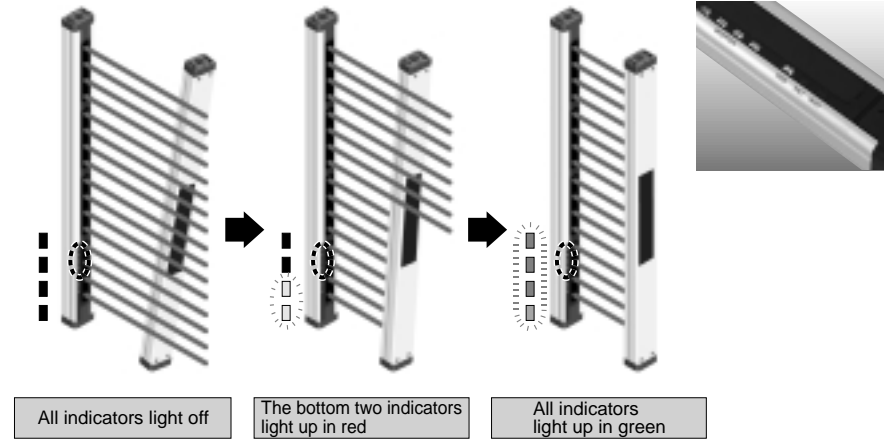

Distinguishes extraneous light to prevent malfunction

The ELC (Éxtraneous Light Check) function prevents malfunction due to extraneous light, such as from other nearby passing sensors, AGVs, patrol lights or spatter light.

※What is the Éxtraneous Light Check (ELC) function? This function distinguishes between light from the sensor itself and light from extraneous sources, and reduces the effect of the extraneous light if it is received by the sensor.

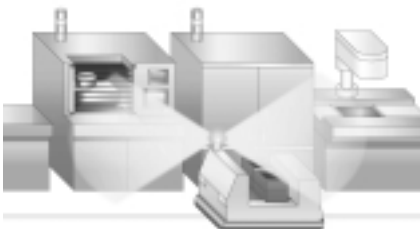

Different types for different needs

There are sensors having a beam pitch of 20 mm 0.787 in (detection capability $\phi 30$ mm $\phi 1.181$ in) and a protective height ranging from 190 mm 7.480 in (8 beam channels) to 1,310 mm 51.575 in (64 beam channels). Plus, there are sensors having an beam pitch of 40 mm 1.575 in (detection capability $\phi 50$ mm $\phi 1.969$ in) and a protective height ranging from 190 mm 7.480 in (4 beam channels) to 1,630 mm 64.173 in (40 beam channels). The sensors can be selected from this wide variety to suit your requirement. PNP output types are also available for all models.

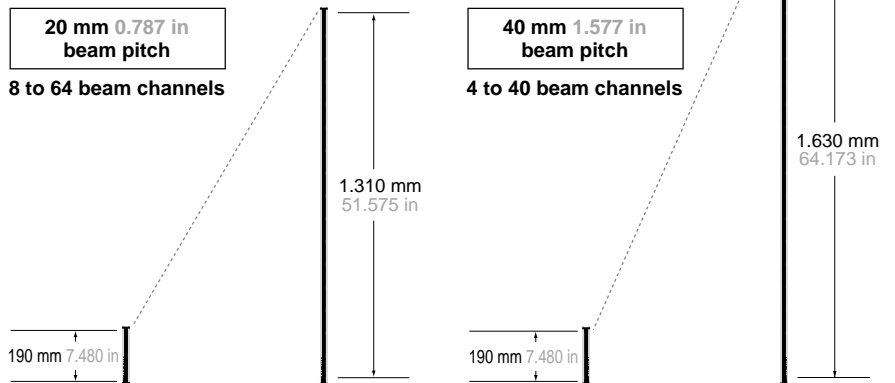

Spatter protection for the sensing surface

The spatter protection hood type, now available, protects the sensing surface from welding machine spatter. Moreover, a front protection cover that can be installed within the sensor casing is also available, completely preventing spatter from adhering to the sensing surface.

In addition, even though sensed objects may contact the sensor, the sensing surface will be protected.



Front protection cover protects the sensing surface

The optional front protection cover (FC-SF2N-A□ / FC-SF4A-H□-H) can be fitted to the sensor to protect the sensing surface even when using the sensor in poor environmental conditions.

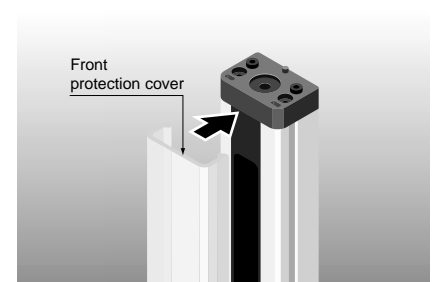

SF2-N

Slit masks boost functionality

By using the optional slit mask (**OS-SF2N-A** / **OS-SF4A-H**), the amount of beam emitted or received can be restrained to reduce the effect of extraneous light from other sensors, etc.

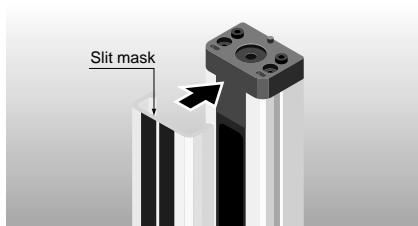

Mounting bracket enables easy beam-axis alignment

The beam-axis alignment is easy since angle adjustment is possible with the enclosed rear mounting bracket (**MS-SF2N-1**). Alternatively, the side mounting bracket (**MS-SF2N-3**) is also available as an option.

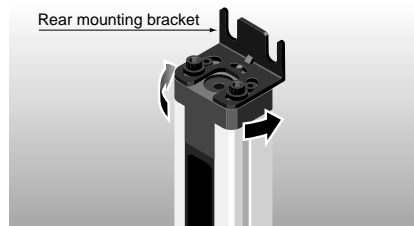

Alignment of beam axes can be accurately performed prior to power-up

By using the **SF-LAT-2N** laser alignment tool, you can quickly and easily align beam axes. The laser beam spot is easy to see, even when light curtain units are installed far apart. In addition, as the **SF-LAT-2N** laser alignment tool is battery-operated, beam axes can be aligned before powering up the light curtain itself.

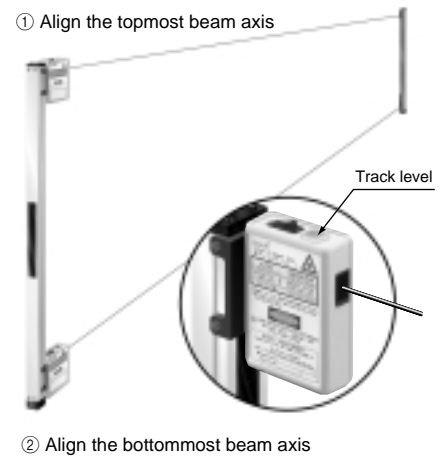

APPLICATIONS

Safeguard for special purpose machine



Detection of entry through the no-entry line

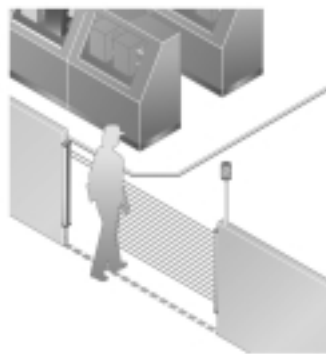

Processing machine intrusion detection



ORDER GUIDE

Sensors Mating cable is not supplied with the sensor. Please order it separately.

Type	Appearance	Operating range (Note 1)	Model No.		Number of beam channels	Protective height (mm in)(Note 2)
			NPN output type	PNP output type		
Normal case	20 mm 0.787 in beam pitch 	0.3 to 7 m 0.984 to 22.966 ft	SF2-NH8	SF2-NH8-PN	8	190 7.480
			SF2-NH12	SF2-NH12-PN	12	270 10.630
			SF2-NH16	SF2-NH16-PN	16	350 13.780
			SF2-NH20	SF2-NH20-PN	20	430 16.929
			SF2-NH24	SF2-NH24-PN	24	510 20.079
			SF2-NH28	SF2-NH28-PN	28	590 23.228
			SF2-NH32	SF2-NH32-PN	32	670 26.378
			SF2-NH36	SF2-NH36-PN	36	750 29.528
			SF2-NH40	SF2-NH40-PN	40	830 32.677
			SF2-NH48	SF2-NH48-PN	48	990 38.976
	SF2-NH56		SF2-NH56-PN	56	1,150 45.276	
	SF2-NH64		SF2-NH64-PN	64	1,310 51.575	
	SF2-NA4		SF2-NA4-PN	4	190 7.480	
	SF2-NA6		SF2-NA6-PN	6	270 10.630	
	SF2-NA8		SF2-NA8-PN	8	350 13.780	
	SF2-NA10		SF2-NA10-PN	10	430 16.929	
	SF2-NA12		SF2-NA12-PN	12	510 20.079	
	SF2-NA14		SF2-NA14-PN	14	590 23.228	
	SF2-NA16		SF2-NA16-PN	16	570 22.441	
	SF2-NA18		SF2-NA18-PN	18	750 29.528	
SF2-NA20	SF2-NA20-PN	20	830 32.677			
SF2-NA24	SF2-NA24-PN	24	990 38.976			
SF2-NA28	SF2-NA28-PN	28	1,150 45.276			
SF2-NA32	SF2-NA32-PN	32	1,310 51.575			
SF2-NA36	SF2-NA36-PN	36	1,470 57.874			
SF2-NA40	SF2-NA40-PN	40	1,630 64.173			
With spatter protection hood	20 mm 0.787 in beam pitch 	SF2-NH8-H	SF2-NH8-PN-H	8	190 7.480	
		SF2-NH12-H	SF2-NH12-PN-H	12	270 10.630	
		SF2-NH16-H	SF2-NH16-PN-H	16	350 13.780	
		SF2-NH20-H	SF2-NH20-PN-H	20	430 16.929	
		SF2-NH24-H	SF2-NH24-PN-H	24	510 20.079	
		SF2-NH28-H	SF2-NH28-PN-H	28	590 23.228	
		SF2-NH32-H	SF2-NH32-PN-H	32	670 26.378	
		SF2-NH36-H	SF2-NH36-PN-H	36	750 29.528	
		SF2-NH40-H	SF2-NH40-PN-H	40	830 32.677	
		SF2-NH48-H	SF2-NH48-PN-H	48	990 38.976	
	SF2-NH56-H	SF2-NH56-PN-H	56	1,150 45.276		
	SF2-NH64-H	SF2-NH64-PN-H	64	1,310 51.575		
	SF2-NA4-H	SF2-NA4-PN-H	4	190 7.480		
	SF2-NA6-H	SF2-NA6-PN-H	6	270 10.630		
	SF2-NA8-H	SF2-NA8-PN-H	8	350 13.780		
	SF2-NA10-H	SF2-NA10-PN-H	10	430 16.929		
	SF2-NA12-H	SF2-NA12-PN-H	12	510 20.079		
	SF2-NA14-H	SF2-NA14-PN-H	14	590 23.228		
	SF2-NA16-H	SF2-NA16-PN-H	16	570 22.441		
	SF2-NA18-H	SF2-NA18-PN-H	18	750 29.528		
SF2-NA20-H	SF2-NA20-PN-H	20	830 32.677			
SF2-NA24-H	SF2-NA24-PN-H	24	990 38.976			
SF2-NA28-H	SF2-NA28-PN-H	28	1,150 45.276			
SF2-NA32-H	SF2-NA32-PN-H	32	1,310 51.575			
SF2-NA36-H	SF2-NA36-PN-H	36	1,470 57.874			
SF2-NA40-H	SF2-NA40-PN-H	40	1,630 64.173			

- Notes: 1) The operating range is the possible setting distance between the emitter and the receiver.
The sensor can detect an object less than 0.3 m 0.984 ft away.
2) Refer to 'TECHNICAL GUIDE' on p.1133 for the definition of the protective height.

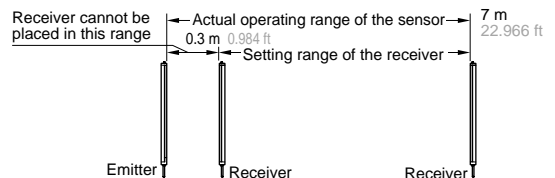

Light Curtain

SF2-N

SF-AC

SF2-EH

SF2-A

SF4-AH

SF2-N

ORDER GUIDE

Safety relay unit

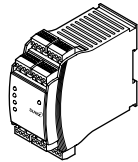
Designation	Appearance	Model No.	Description
Safety relay unit (For PNP output type light curtain)		SF-AC	Safety relay unit for PNP output type • Complies with Control Categories up to 4 based on EN 954-1

Note: For more details about the **SF-AC**, refer to [p.500](#).

Mating cables Mating cable is not supplied with the sensor. Please order it separately.

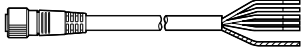
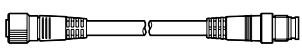
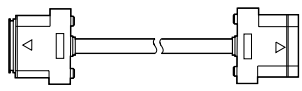
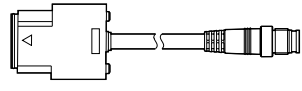
Designation	Appearance	Model No.	Description
Cable with connector on one end		SF2N-CC3	Length: 3 m 9.843 ft Weight: 400 g approx. (two cables)
		SF2N-CC7	Length: 7 m 22.966 ft Weight: 870 g approx. (two cables)
		SF2N-CC10	Length: 10 m 32.808 ft Weight: 1,200 g approx. (two cables)
Cable with connector on both ends		SF2N-CCJ10	Length: 10 m 32.808 ft Weight: 1,200 g approx. (two cables)
Cable for series connection		SF2N-CSL02	Length: 200 mm 7.874 in Weight: 80 g approx. (two cables)
		SF2N-CSL05	Length: 500 mm 19.685 in Weight: 110 g approx. (two cables)
Bottom cap cable for series connection (Note)		SF2N-CB05	Length: 500 mm 19.685 in Weight: 120 g approx. (two cables)

Note: Note that the dimensions of **SF2-N** series will change when using the bottom cap cable for series connection (**SF2N-CB05**). Refer to 'DIMENSIONS' on [p.481](#) and [p.482](#).

Caution



- In case **SF2-N** series sensors are connected in series under the conditions mentioned below, replace the bottom cap cable, enclosed with **SF2-N** series, by the optional bottom cap cable for series connection (**SF2N-CB05**).
If it is not replaced, the internal protection circuit of **SF2-N** series may work, causing a breakdown.
- In case the number of sets connected in series is three.
- In case the total number of beam channels connected in series exceeds the following
SF2-NH□(-PN)(-H): 48 beam channels
SF2-NA□(-PN)(-H): 24 beam channels

Example for bottom cap cable replacement

Product used (Note 1)	No. of sets	Total No. of beam channels	Bottom cap cable
SF2N-NH64	1 set	64	Attached bottom cap cable
SF2N-NH24 SF2N-NH24	2 sets	48	Attached bottom cap cable
SF2N-NH24 SF2N-NH28	2 sets	52	Optional bottom cap cable for series connection (SF2N-CB05) (Note 2)
SF2N-NH24 SF2N-NH12 SF2N-NH12	3 sets	48	Optional bottom cap cable for series connection (SF2N-CB05) (Note 2)

Notes: 1) Series connection is not possible between a 20 mm (0.787 in) beam pitch type sensor and a 40 mm (1.575 in) beam pitch type sensor.
2) Note that the dimensions of **SF2-N** series will change when using the bottom cap cable for series connection (**SF2N-CB05**).
Refer to 'DIMENSIONS' on [p.481](#) and [p.482](#).

ORDER GUIDE

Spare parts (Accessory for sensor)

Designation	Model No.	Description
Rear mounting bracket	MS-SF2N-1	Used to mount the sensor on the rear surface (1 set for emitter and receiver)
U-shaped rear mounting intermediate supporting bracket (Note)	MS-SF2N-2	For SF2-N□(-PN)
	MS-SF4A-H2	For SF2-N□(-PN)-H
L-shaped intermediate supporting bracket (Note)	MS-SF2N-L	Used to install the intermediate supporting bracket on the wall side, etc. (1 set for emitter and receiver)
Test rod	SF2-NH-TR	Used for standard sensing to detect the smallest objects (φ30 mm φ1.181 in), with 20 mm 0.787 in beam pitch

Note: The number of sets required varies depending on the product. Refer to 'DIMENSIONS' on p.483 and p.484 for further details.

Rear mounting bracket • MS-SF2N-1

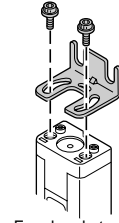

Four bracket set
Eight M3 (length 5 mm 0.197 in) hexagon-socket-head bolts are attached.

U-shaped rear mounting intermediate supporting bracket L-shaped intermediate supporting bracket

- MS-SF2N-2
- MS-SF4A-H2
- MS-SF2N-L

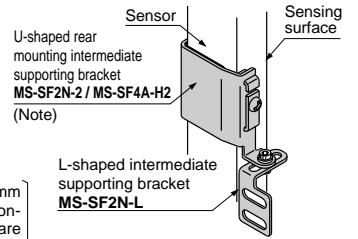

Note: The above figure is only applicable to the MS-SF2N-2. The MS-SF4A-H2 has a different shape.

- MS-SF2N-2 / MS-SF4A-H2
Set of 2 pcs. each of U-shaped rear supporting bracket and retaining plate
- MS-SF2N-L
Two L-shaped bracket set
Two M3 (length 10 mm 0.394 in) pan head screws, two M4 (length 10 mm 0.394 in) hexagon-socket-head bolts and two nuts are attached.

OPTIONS

Designation	Applicable beam channels 20 mm 0.787 in beam pitch 40 mm 1.575 in beam pitch	8 beam channels	12 beam channels	16 beam channels	20 beam channels	24 beam channels	28 beam channels	32 beam channels	36 beam channels	40 beam channels	48 beam channels	56 beam channels	64 beam channels	36 beam channels	40 beam channels
		4 beam channels	6 beam channels	8 beam channels	10 beam channels	12 beam channels	14 beam channels	16 beam channels	18 beam channels	20 beam channels	24 beam channels	28 beam channels	32 beam channels	FC-SF2N-A36	FC-SF2N-A40
Front protection cover	For SF2-N□(-PN)	Model No. FC-SF2N-A4	FC-SF2N-A6	FC-SF2N-A8	FC-SF2N-A10	FC-SF2N-A12	FC-SF2N-A14	FC-SF2N-A16	FC-SF2N-A18	FC-SF2N-A20	FC-SF2N-A24	FC-SF2N-A28	FC-SF2N-A32	FC-SF2N-A36	FC-SF2N-A40
	For SF2-N□(-PN)-H	Model No. FC-SF4A-H8-H	FC-SF4A-H12-H	FC-SF4A-H16-H	FC-SF4A-H20-H	FC-SF4A-H24-H	FC-SF4A-H28-H	FC-SF4A-H32-H	FC-SF4A-H36-H	FC-SF4A-H40-H	FC-SF4A-H48-H	FC-SF4A-H56-H	FC-SF4A-H64-H	FC-SF4A-H72-H	FC-SF4A-H80-H
Slit mask	For SF2-N□(-PN)	Model No. OS-SF2N-A4	OS-SF2N-A6	OS-SF2N-A8	OS-SF2N-A10	OS-SF2N-A12	OS-SF2N-A14	OS-SF2N-A16	OS-SF2N-A18	OS-SF2N-A20	OS-SF2N-A24	OS-SF2N-A28	OS-SF2N-A32	OS-SF2N-A36	OS-SF2N-A40
	For SF2-N□(-PN)-H	Model No. OS-SF4A-H8-H	OS-SF4A-H12-H	OS-SF4A-H16-H	OS-SF4A-H20-H	OS-SF4A-H24-H	OS-SF4A-H28-H	OS-SF4A-H32-H	OS-SF4A-H36-H	OS-SF4A-H40-H	OS-SF4A-H48-H	OS-SF4A-H56-H	OS-SF4A-H64-H	OS-SF4A-H72-H	OS-SF4A-H80-H

Note: The model Nos. given above denote a single unit, not a pair of units. 2 pcs. (2 sets) are required to mount the emitter / receiver.

Front protection cover

- FC-SF2N-A□

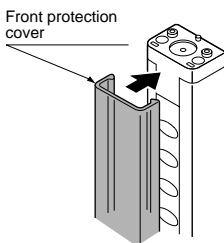

- FC-SF4A-H□-H

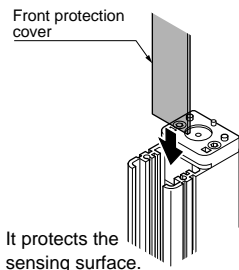

Slit mask

- OS-SF2N-A□

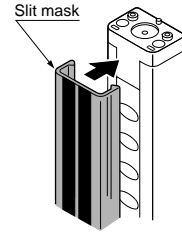

- OS-SF4A-H□-H

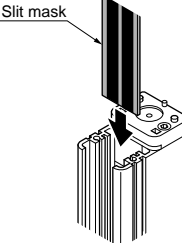

The slit mask restrains the amount of beam emitted or received and hence reduces the interference between neighboring sensors. It is also used in cases when the beam intensity is too strong penetrating through the sensing object. However, the operating range reduces when the slit mask is used.

Operating range

- <OS-SF2N-A□ / OS-SF4A-H□-H>
- Slit on the emitter side: 2.6 m 8.530 ft
- Slit on the receiver side: 2.6 m 8.530 ft
- Slit on both sides: 1.2 m 3.937 ft

SF2-N

OPTIONS

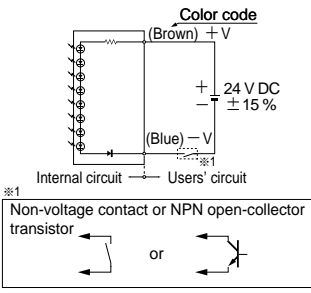
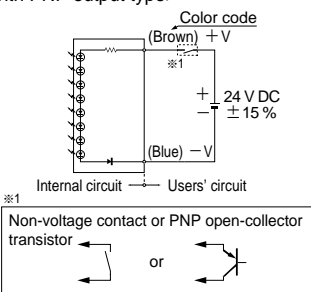
Designation	Model No.	Description
Large display unit for light curtain	SF-IND-2	<p>With the large display unit put on the light curtain, the operation is easily observable from various directions.</p> <p>Specifications</p> <ul style="list-style-type: none"> • Supply voltage: 24 V DC \pm 15 % • Current consumption: 12 mA or less • Indicators: Orange LED (8 pcs. used) [Light up when external contact is ON] • Ambient temperature: -10 to $+55$ °C $+14$ to $+131$ °F (No dew condensation or icing allowed) • Material: POM (Case) Polycarbonate (Cover) Cold rolled carbon steel (SPCC)(Bracket) • Cable: 0.3 mm² 2-core cabtyre cable, 3 m 9.843 ft long • Weight: 70 g approx. (including bracket) <p>I/O circuit diagrams</p> <p><With NPN output type></p>  <p><With PNP output type></p> 
Side mounting bracket	MS-SF2N-3	Used for side-mounting of sensors (four bracket set for emitter and receiver)
U-shaped side mounting intermediate supporting bracket (Note 1)	MS-SF2N-4 MS-SF4A-H4	For SF2-N□(-PN) Used to hold the sensor at the intermediate position for protection against vibration (for side mounting)(1 set for emitter and receiver) For SF2-N□(-PN)-H
Center sensor mounting bracket (Note 2)	MS-SF2N-5	Used for one-point rear mounting Convenient for mounting on an aluminum frame (four bracket set for emitter and receiver)
Test rod	SF2-NA-TR	Used for standard sensing to detect the smallest objects (ϕ 50 mm ϕ 1.969 in), with 40 mm 1.575 in beam pitch
Laser alignment tool (Note 3)	SF-LAT-2N	Easy to align the beam axis with the visible laser beam

Note: 1) The number of sets required varies depending on the product. Refer to 'DIMENSIONS' on p.485~ for further details.

- Multiple beam channel sensors requiring the intermediate supporting bracket (20 mm 0.787 in beam pitch type : 36 beam channels or more, 40 mm 1.575 in beam pitch type: 18 beam channels or more) cannot be mounted on an aluminum frame with the center sensor mounting bracket.
- Refer to 'SF4-AH series' on p.420~ for further details about the laser alignment tool.

Large display unit for light curtain

• SF-IND-2

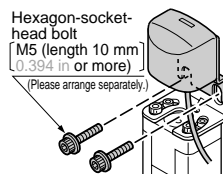

Attaches to upper edge of light curtain.
Tighten together the mounting bracket provided with the area sensor and the mounting bracket of SF-IND-2.

Side mounting bracket

• MS-SF2N-3

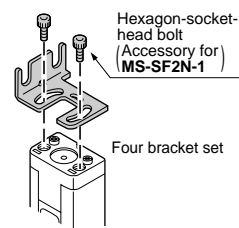

Center sensor mounting bracket

• MS-SF2N-5

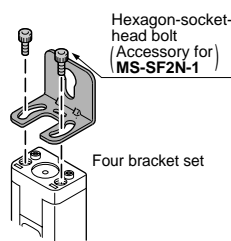

U-shaped side mounting intermediate supporting bracket

• MS-SF2N-4
• MS-SF4A-H4

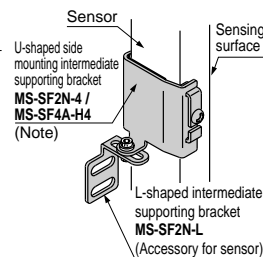

Note: The above figure is only applicable to the MS-SF2N-4. The MS-SF4A-H4 has a different shape.

- MS-SF2N-4 / MS-SF4A-H4
Set of 2 pcs. each of U-shaped side supporting bracket and retaining plate
- MS-SF2N-L (Accessory for sensor)
Two L-shaped bracket set
Two M3 (length 10 mm 0.394 in) pan head screws, two M4 (length 10 mm 0.394 in) hexagon-socket-head bolts and two nuts are attached.

Laser alignment tool

• SF-LAT-2N

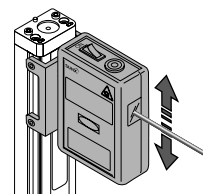

SPECIFICATIONS

Individual specifications

SF2-NH□(-H)

Item	Type		20 mm 0.787 in beam pitch							
	Model No.	NPN output	SF2-NH8(-H)	SF2-NH12(-H)	SF2-NH16(-H)	SF2-NH20(-H)	SF2-NH24(-H)	SF2-NH28(-H)	SF2-NH32(-H)	SF2-NH36(-H)
		PNP output	SF2-NH8-PN(-H)	SF2-NH12-PN(-H)	SF2-NH16-PN(-H)	SF2-NH20-PN(-H)	SF2-NH24-PN(-H)	SF2-NH28-PN(-H)	SF2-NH32-PN(-H)	SF2-NH36-PN(-H)
No. of beam channels			8	12	16	20	24	28	32	36
Beam pitch			20 mm 0.787 in							
Protective height			190 mm 7.480 in	270 mm 10.630 in	350 mm 13.780 in	430 mm 16.929 in	510 mm 20.079 in	590 mm 23.228 in	670 mm 26.378 in	750 mm 29.528 in
Current consumption			Emitter: 60 mA or less, Receiver 100 mA or less				Emitter: 90 mA or less, Receiver 150 mA or less			
Weight (Total of emitter and receiver)	SF2-NH□(-PN)		390 g approx.	490 g approx.	580 g approx.	680 g approx.	790 g approx.	870 g approx.	980 g approx.	1,070 g approx.
	SF2-NH□(-PN)-H		440 g approx.	590 g approx.	730 g approx.	890 g approx.	1,000 g approx.	1,200 g approx.	1,300 g approx.	1,500 g approx.

Item	Type		20 mm 0.787 in beam pitch			
	Model No.	NPN output	SF2-NH40(-H)	SF2-NH48(-H)	SF2-NH56(-H)	SF2-NH64(-H)
		PNP output	SF2-NH40-PN(-H)	SF2-NH48-PN(-H)	SF2-NH56-PN(-H)	SF2-NH64-PN(-H)
No. of beam channels			40	48	56	64
Beam pitch			20 mm 0.787 in			
Protective height			830 mm 32.677 in	990 mm 38.976 in	1,150 mm 45.276 in	1,310 mm 51.575 in
Current consumption			Emitter: 90 mA or less, Receiver 150 mA or less		Emitter: 120 mA or less, Receiver 220 mA or less	
Weight (Total of emitter and receiver)	SF2-NH□(-PN)		1,160 g approx.	1,370 g approx.	1,550 g approx.	1,800 g approx.
	SF2-NH□(-PN)-H		1,600 g approx.	1,900 g approx.	2,200 g approx.	2,500 g approx.

SF2-NA□(-H)

Item	Type		40 mm 1.575 in beam pitch							
	Model No.	NPN output	SF2-NA4(-H)	SF2-NA6(-H)	SF2-NA8(-H)	SF2-NA10(-H)	SF2-NA12(-H)	SF2-NA14(-H)	SF2-NA16(-H)	SF2-NA18(-H)
		PNP output	SF2-NA4-PN(-H)	SF2-NA6-PN(-H)	SF2-NA8-PN(-H)	SF2-NA10-PN(-H)	SF2-NA12-PN(-H)	SF2-NA14-PN(-H)	SF2-NA16-PN(-H)	SF2-NA18-PN(-H)
No. of beam channels			4	6	8	10	12	14	16	18
Beam pitch			40 mm 1.575 in							
Protective height			190 mm 7.480 in	270 mm 10.630 in	350 mm 13.780 in	430 mm 16.929 in	510 mm 20.079 in	590 mm 23.228 in	670 mm 26.378 in	750 mm 29.528 in
Current consumption			Emitter : 60 mA or less, Receiver 100 mA or less				Emitter : 90 mA or less, Receiver 150 mA or less			
Weight (Total of emitter and receiver)	SF2-NA□(-PN)		390 g approx.	490 g approx.	580 g approx.	680 g approx.	790 g approx.	870 g approx.	980 g approx.	1,070 g approx.
	SF2-NA□(-PN)-H		440 g approx.	590 g approx.	730 g approx.	890 g approx.	1,000 g approx.	1,200 g approx.	1,300 g approx.	1,500 g approx.

Item	Type		40 mm 1.575 in beam pitch					
	Model No.	NPN output	SF2-NA20(-H)	SF2-NA24(-H)	SF2-NA28(-H)	SF2-NA32(-H)	SF2-NA36(-H)	SF2-NA40(-H)
		PNP output	SF2-NA20-PN(-H)	SF2-NA24-PN(-H)	SF2-NA28-PN(-H)	SF2-NA32-PN(-H)	SF2-NA36-PN(-H)	SF2-NA40-PN(-H)
No. of beam channels			20	24	28	32	36	40
Beam pitch			40 mm 1.575 in					
Protective height			830 mm 32.677 in	990 mm 38.976 in	1,150 mm 45.276 in	1,310 mm 51.575 in	1,470 mm 57.874 in	1,630 mm 61.173 in
Current consumption			Emitter: 90 mA or less, Receiver 150 mA or less		Emitter: 120 mA or less, Receiver 220 mA or less			
Weight (Total of emitter and receiver)	SF2-NA□(-PN)		1,160 g approx.	1,370 g approx.	1,550 g approx.	1,800 g approx.	1,940 g approx.	2,130 g approx.
	SF2-NA□(-PN)-H		1,600 g approx.	1,900 g approx.	2,200 g approx.	2,500 g approx.	2,800 g approx.	3,000 g approx.

SF4-AH

SF2-A

Light Curtain
SF2-N

SF2-EH

Safety Relay Unit
SF-AC

SF2-N

SPECIFICATIONS

Common specifications

Type		20 mm 0.787 in beam pitch		40 mm 1.575 in beam pitch	
		NPN output	PNP output	NPN output	PNP output
Item	Model No.	SF2-NH□(-H)	SF2-NH□-PN(-H)	SF2-NA□(-H)	SF2-NA□-PN(-H)
Applicable standards	Category 2 based on EN 954-1 (Type 2 based on IEC 61496-1/2)				
Operating range	0.3 to 7 m 0.984 to 22.966 ft				
Detection capability	φ30 mm φ1.181 in opaque object		φ50 mm φ1.969 in opaque object		
Effective aperture angle	± 5 ° or less for a operating range exceeding 3 m 9.843 ft (conforming to IEC 61496-2 / UL 61496-2)				
Supply voltage	24 V DC ± 15 % Ripple P-P 10 % or less				
Control output (OSSD)	<NPN output type> NPN open-collector transistor • Maximum sink current: 200 mA • Applied voltage: Same as supply voltage (between control output and 0 V) • Residual voltage: 2.0 V or less (at 200 mA sink current)		<PNP output type> PNP open-collector transistor • Maximum source current: 200 mA • Applied voltage: Same as supply voltage (between control output and + V) • Residual voltage: 2.5 V or less (at 200 mA source current)		
	Utilization category	DC-12 or DC-13			
	Operation mode	ON when all beam channels are received, OFF when one or more beam channels are interrupted (OFF also in case of any malfunction in the sensor or the synchronization signal)			
	Protection circuit	Incorporated			
Response time	OFF response: 15 ms or less, ON response: 28 ms or less (under stable light received condition)				
Alarm output	<NPN output type> NPN open-collector transistor • Maximum sink current: 60 mA • Applied voltage: Same as supply voltage (between alarm output and 0 V) • Residual voltage: 2.0 V or less (at 60 mA sink current)		<PNP output type> PNP open-collector transistor • Maximum source current: 60 mA • Applied voltage: Same as supply voltage (between alarm output and + V) • Residual voltage: 2.5 V or less (at 60 mA source current)		
	Operation mode	Normal operation: Alarm output ON, Failure resulting in emission halt, or when test input is applied: Alarm output OFF			
	Protection circuit	Incorporated			
Indicators	Emitter	Beam-axis alignment indicators: 2-color (Red / Green) LED × 4 (lights up in red when the each beam channel receives light, light up in green when all beams are received), Operation indicator (Note 1): 2-color (Red / Green) LED (lights up in red when control output (OSSD) is OFF, lights up in green when control output (OSSD) is ON), Emission halt indicator: Orange LED (lights up when emission halts), Fault indicator: Yellow LED (lights up or blinks if a fault occurs in the sensor)			
	Receiver	Beam-axis alignment indicators: 2-color (Red / Green) LED × 4 (lights up in red when the each beam channel receives light, light up in green when all beams are received), OSSD indicator: 2-color (Red / Green) LED (lights up in red when control output (OSSD) is OFF, lights up in green when control output (OSSD) is ON), Unstable incident beam indicator: Orange LED (lights up when light received is unstable), Fault indicator: Yellow LED (lights up or blinks if a fault occurs in the sensor)			
Test input (emission halt) function	Incorporated				
Master / Slave selection input	Connection to 0 V (Low): Master mode operation, Open (High): Slave mode operation				
Interference prevention function	Incorporated	(Series connection: 3 sets max. [SF2-NH□(-PN)(-H)]: total 128 beam channels max., SF2-NA□(-PN)(-H): total 64 beam channels max.) Parallel connection: 2 sets max. Series and parallel mixed connection: Series connection of 3 sets max. and parallel connection of 2 sets max. are simultaneously possible. 20 mm 0.787 in beam pitch type and 40 mm 1.575 in beam pitch type cannot be combined together in series connection.			
Environmental resistance	Pollution degree	3 (Industrial environment)			
	Degree of protection	IP65 (IEC)			
	Ambient temperature / Ambient humidity	- 10 to + 55°C + 14 to + 131 °F (No dew condensation or icing allowed), Storage: - 25 to + 70°C - 13 to + 158 °F / 30 to 85 % RH, Storage: 30 to 95 % RH			
	Ambient illuminance	Sunlight: 20,000 lx at the light-receiving face, Incandescent light: 3,500 lx at the light-receiving face			
	Dielectric strength voltage / Insulation resistance	1,000 V AC for one min. between all supply terminals connected together and enclosure (Note 2) / 20 MΩ, or more, with 500 V DC megger between all supply terminals connected together and enclosure (Note 2)			
Vibration resistance / Shock resistance	10 to 55 Hz frequency, 0.75 mm 0.030 in amplitude in X, Y and Z directions for two hours each / 300 m/s ² acceleration (30 G approx.) in X, Y and Z directions for three times each				
Emitting element	Infrared LED (Peak emission wavelength: 870 nm 0.034 mil)				
Material	Enclosure: Aluminium, Resin case: ABS, Lens: Polycarbonate, Cap: PBT				
Cable	Emitter: 6-core (0.3 mm ² × 4-core, 0.2 mm ² × 2-core) shielded cable, 0.5 m 1.640 ft long, with a connector at the end Receiver: 7-core (0.3 mm ² × 5-core, 0.2 mm ² × 2-core) shielded cable, 0.5 m 1.640 ft long, with a connector at the end				
Cable extension	Extension up to total 20.5 m 67.257 ft is possible, for both emitter and receiver, with optional mating cables.				
Accessories	MS-SF2N-1 (Rear mounting bracket): 1 set for emitter and receiver MS-SF2N-2 (U-shaped rear mounting intermediate supporting bracket, MS-SF4A-H2 for 'H' type): (Note 3) MS-SF2N-L (L-shaped intermediate supporting bracket): (Note 3) SF2-NH-TR (Test rod): 1 pc. [SF2-NH□(-PN)(-H) only]				

Notes: 1) Since the color of operation indicator changes according to the ON / OFF state of control output (OSSD), the operation indicator is marked as 'OSSD' on the sensor.
 2) Surge absorber is connected between the main body enclosure and the supply terminals to avoid faulty operation due to surge. For this reason, the values for dielectric strength voltage and insulation resistance are given for the condition when the surge absorber has been removed.
 3) U-shaped rear mounting intermediate supporting bracket (**MS-SF2N-2** or **MS-SF4A-H2**) and L-shaped intermediate supporting bracket (**MS-SF2N-L**) are attached with the following sensors. The number of attached U-shaped rear mounting intermediate supporting bracket and L-shaped intermediate supporting bracket are different depending on the sensor as follows.
SF2-NH36(-PN)(-H), SF2-NH40(-PN)(-H), SF2-NA18(-PN)(-H), SF2-NA20(-PN)(-H): 1 set, **SF2-NH48(-PN)(-H), SF2-NA24(-PN)(-H):** 2 sets
SF2-NH56(-PN)(-H), SF2-NH64(-PN)(-H), SF2-NA28(-PN)(-H), SF2-NA32(-PN)(-H), SF2-NA36(-PN)(-H): 3 sets, **SF2-NA40(-PN)(-H):** 4 sets

I/O CIRCUIT AND WIRING DIAGRAMS

NPN output type

I/O circuit diagram

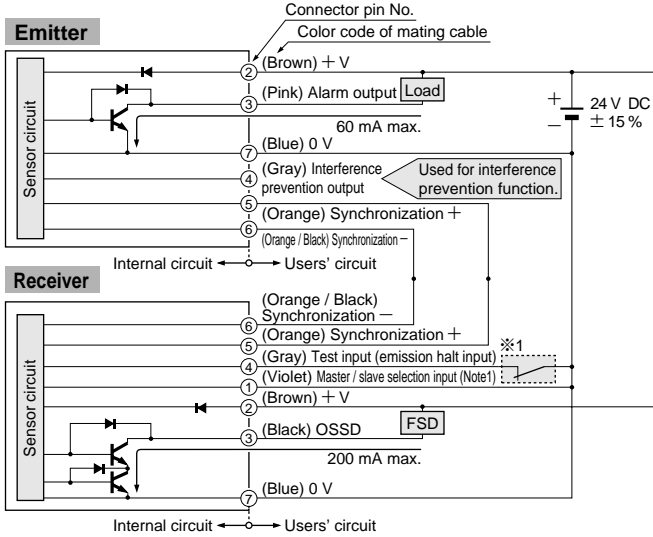

- Notes: 1) Refer to p.478 for master / slave selection input.
 2) Unused wires must be insulated to ensure that they do not come into contact with wires already in use.

CAUTION

Use a safety relay unit or an equivalent safety control circuit for FSD.

※1

Non-voltage contact or NPN open-collector transistor

- Test input (emission halt input)
- 0 to +1.5 V: Emission (sink current: 2 mA or less)
- Open, or +4 V to Vs: Emission halt (Note)

Note: Vs is the same voltage as the voltage of the power supply to be used.

Wiring diagram

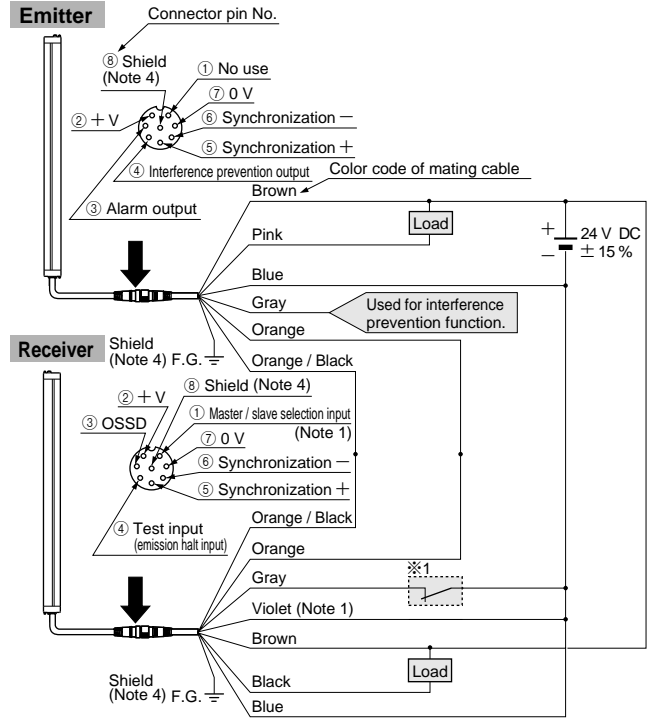

- Notes: 1) Refer to p.478 for master / slave selection input.
 2) Unused wires must be insulated to ensure that they do not come into contact with wires already in use.
 3) Conductor cross-section area of lead wire of mating cable is 0.2 mm² (synchronization wire) and 0.3 mm² (exclude synchronization wire).
 4) Be sure to connect the shield wire to the frame ground (F.G.).

SF2-N

I/O CIRCUIT AND WIRING DIAGRAMS

PNP output type

I/O circuit diagram

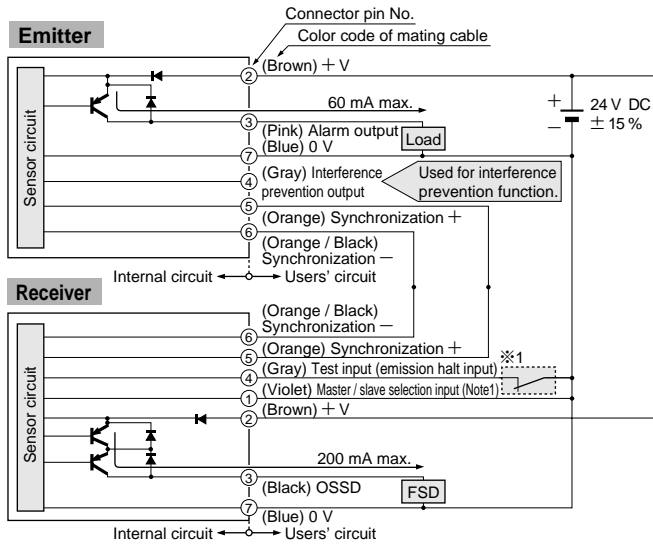

Notes: 1) Refer to p.478 for master / slave selection input.
2) Unused wires must be insulated to ensure that they do not come into contact with wires already in use.

CAUTION

Use a safety relay unit or an equivalent safety control circuit for FSD.

※1

Non-voltage contact or NPN open-collector transistor

• Test input (emission halt input)
0 to +1.5 V: Emission (sink current: 2 mA or less)
Open, or +4 V to Vs: Emission halt (Note)

Note: Vs is the same voltage as the voltage of the power supply to be used.

Wiring diagram

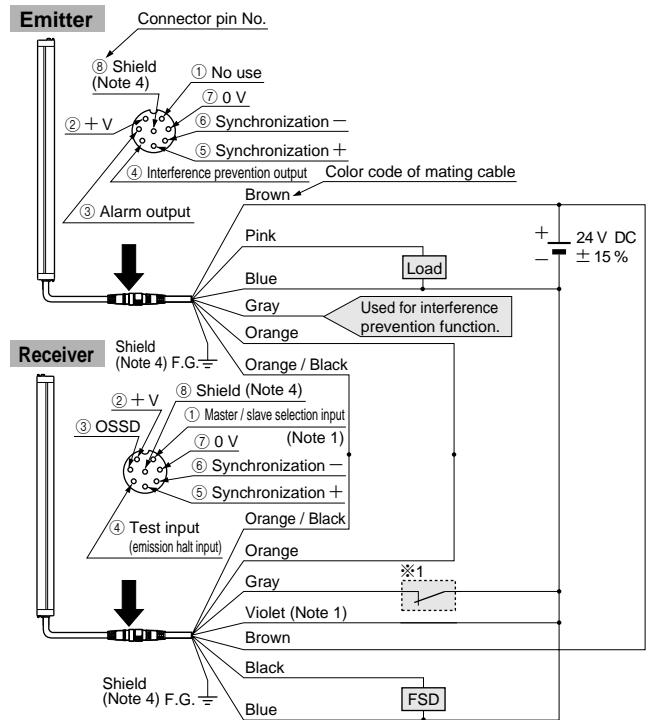

Notes: 1) Refer to p.478 for master / slave selection input.
2) Unused wires must be insulated to ensure that they do not come into contact with wires already in use.
3) Conductor cross-section area of lead wire of mating cable is 0.2 mm² (synchronization wire) and 0.3 mm² (exclude synchronization wire).
4) Be sure to connect the shield wire to the frame ground (F.G.).

SF-AC wiring diagram (Control category 2)

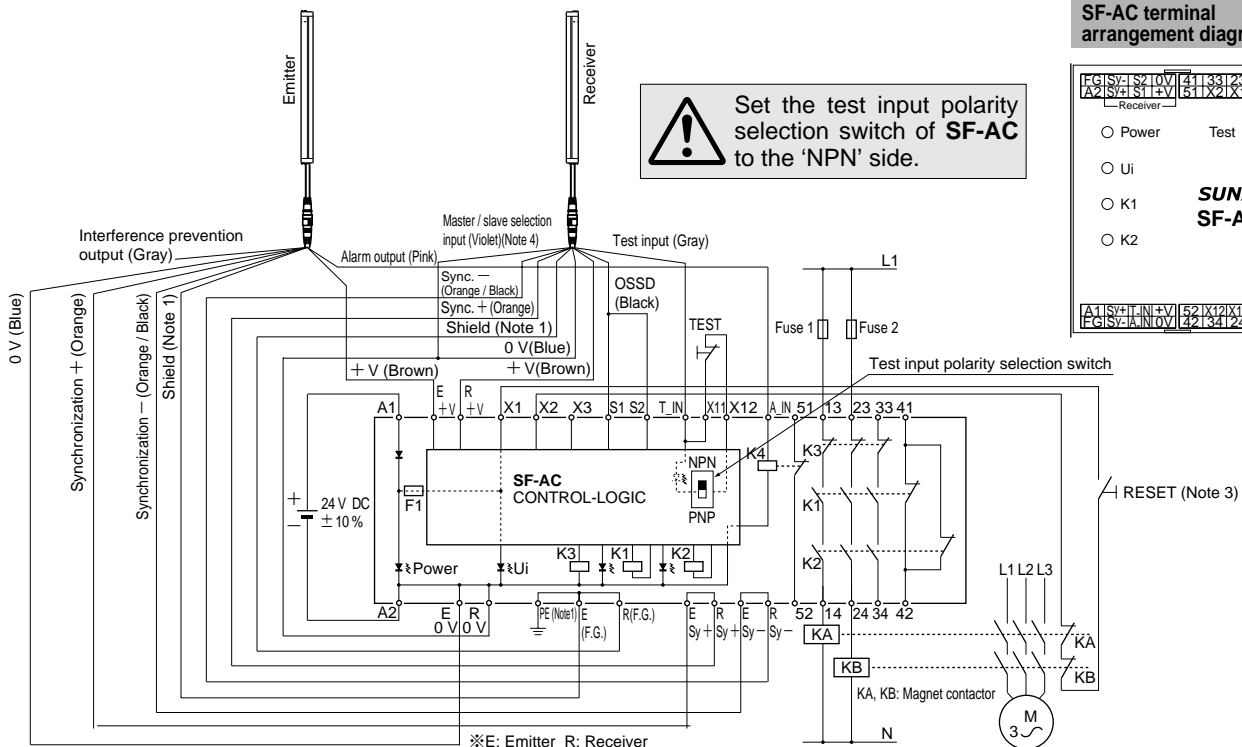

Notes: 1) Connect the light curtain's shield wire to the frame ground (F.G.), and ground the SF-AC's PE terminal.
2) If using the equipment with the manual reset, wire X1 to X2 as per the illustration above. If using with the automatic reset, disconnect X2 wire and connect it to X3. In this case, reset button is not required.
3) Use a momentary-type switch for the reset button.
4) Refer to p.478 for details pertaining to the master / slave selection input.

PRECAUTIONS FOR PROPER USE

Refer to p.1135~ for general precautions.

Part description and function

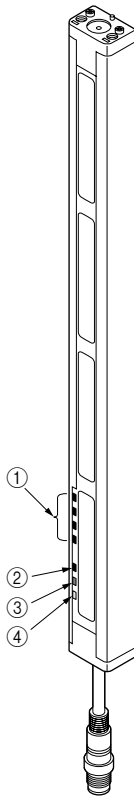

	Description	Function
Emitter	① Beam-axis alignment indicator [RECEPTION] (Red / Green LED)	Top: Lights up in red when sensor top receives lights Upper middle: Lights up in red when sensor upper middle receives light Lower middle: Lights up in red when sensor lower middle receives light Bottom: Lights up in red when sensor bottom receives light Lights up in green when all beam channels (top, upper middle, lower middle and bottom) receive light
	② Operation indicator [OSSD] (Note 1) (Red / Green LED)	Lights up in red when control output (OSSD) is OFF, lights up in green when control output (OSSD) is ON
	③ Emission halt indicator [HALT] (Orange LED)	Lights up when emission halts
	④ Fault indicator [FAULT] (Yellow LED)	Lights up or blinks when a fault occurs in the sensor (Note 2) 1 blink: Beam channel No. error (The end cap is not connected correctly.) 2 blinks: Series connection error (The cable for series connection is not connected correctly.) 3 blinks: Total unit No. / total beam channel No. error (When more than 3 sets of sensors are serially connected or when a total of 128 beam channels [SF2-NA□(-PN)(-H): 64 beam channels] are exceeded.) 4 or more blinks, or lights: Others (Please contact our office.)
Receiver	① Beam-axis alignment indicator [RECEPTION] (Red / Green LED)	Top: Lights up in red when sensor top receives lights Upper middle: Lights up in red when sensor upper middle receives light Lower middle: Lights up in red when sensor lower middle receives light Bottom: Lights up in red when sensor bottom receives light Lights up in green when all beam channels (top, upper middle, lower middle and bottom) receive light
	② OSSD indicator [OSSD] (Red / Green LED)	Lights up in red when control output (OSSD) is OFF, lights up in green when control output (OSSD) is ON
	③ Unstable incident beam indicator [STB.] (Orange LED)	Lights up when light received is unstable
	④ Fault indicator [FAULT] (Yellow LED)	Lights up or blinks when a fault occurs in the sensor (Note 2) Lights up: control output (OSSD) wires are not connected securely 1 blink: Beam channel No. error (The end cap is not connected correctly.) 2 blinks: Series connection error (The cable for series connection is not connected correctly.) 3 blinks: Total unit No. / total beam channel No. error (When more than 3 sets of sensors are serially connected or when a total of 128 beam channels [SF2-NA□(-PN)(-H): 64 beam channels] are exceeded.) 4 blinks: Received extraneous light error 5 or more blinks: Others (Please contact our office.)

- Notes: 1) Since the color of the operation indicator changes according to the ON / OFF state of 'OSSD', the operation indicator is marked as OSSD on the sensor.
2) The blinking cycle of the fault indicator is illustrated below. The number of blinks indicate what kind of fault has occurred. There is an interval of approx. 1 sec. between blinking.

Blinking cycle of fault indicator

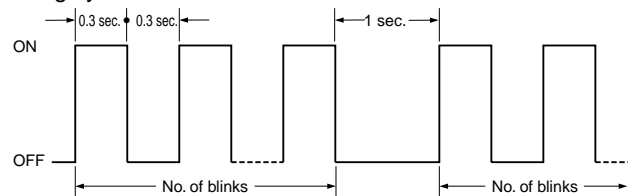

Wiring



Refer to the applicable regulations for the region where this device is to be used when setting up the device. In addition, make sure that all necessary measures are taken to prevent possible dangerous operating errors resulting from earth faults.

- Make sure that the power supply is off while wiring.
- Verify that the supply voltage variation is within the rating.
- If power is supplied from a commercial switching regulator, ensure that the frame ground (F.G.) terminal of the power supply is connected to an actual ground.
- In case noise generating equipment (switching regulator, inverter motor, etc.) is used in the vicinity of this sensor, connect the frame ground (F.G.) terminal of the equipment to an actual ground.
- Do not run the wires together with high-voltage lines or power lines or put them in the same raceway. This can cause malfunction due to induction.

Others

- Do not use during the initial transient time (2 sec.) after the power supply is switched on.
- Avoid dust, dirt and steam.
- Take care that the sensor does not come in direct contact with water, oil, grease, or organic solvents, such as, thinner, etc.
- Take care that the sensor is not directly exposed to fluorescent light from a rapid-starter lamp or a high frequency lighting device, as it may affect the sensing performance.

SF2-N

PRECAUTIONS FOR PROPER USE

Refer to p.1135~ for general precautions.



- Do not utilize this sensor in 'PSDI Mode', in which the sensor is utilized as an activator for machinery.
- To use this product in the U.S.A., refer to OSHA 1910.212 and OSHA 1910.217 for installation, and in Europe, refer to EN 999 as well. Observe your national and local requirements before installing this product.
- This sensor is a Type 2 electro-sensitive protective equipment. It is specified that this sensor be utilized only within systems implementing safety categories 2, 1 and B (safety-related categories for control systems), as determined by European Standard EN 954-1. This sensor must never be utilized in any system that requires the usage of category 4 equipment, such as press machines; nor for systems requiring category 3 equipment.

• This catalog is a guide to select a suitable product. Be sure to read the instruction manual attached to the product prior to its use.

- Make sure to carry out the test run before regular operation.
- This safety system is for use only on machinery in which the dangerous parts can be stopped immediately, either by an emergency stop unit or by disconnecting the power supply. Do not use this system with machinery which cannot be stopped at any point in its operation cycle.

Sensing area



- Make sure to install this product such that any part of the human body that passes through the sensing area is detected before it reaches dangerous machine parts. If the human body is not detected, there is a danger of serious injury or death.
- Do not use any reflective type or retroreflective type arrangement.

Correct mounting method

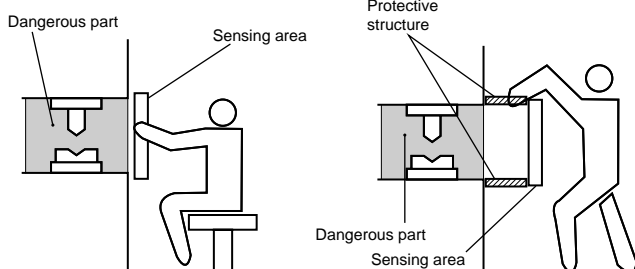

Wrong mounting method

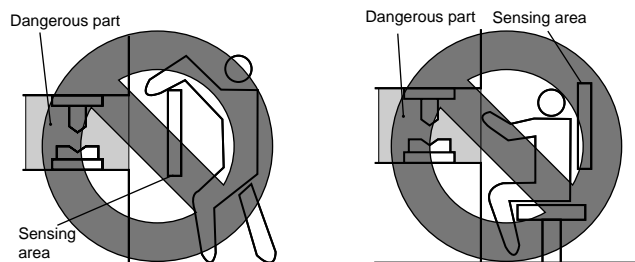

Safety distance



- Calculate the safety distance correctly, and always maintain a distance which is equal to or greater than the safety distance, between the sensing area of this sensor and the dangerous parts of the machinery. If the safety distance is miscalculated or if sufficient distance is not maintained, there is a danger of serious injury or death.
- Before designing the system, refer to the relevant standards of the region where this device is to be used and then install this device.

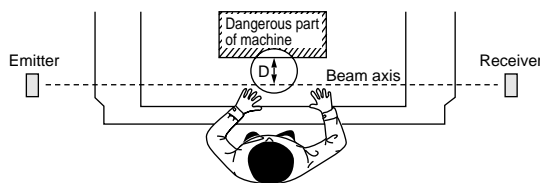

- Safety distance is calculated based on the following equation when a person moves perpendicular (normal intrusion) to the sensing area of the sensor. (Please check the latest standards for the equation.)

For use in Europe (as per EN 999)

- Equation ① $D = K \times T + C$
- D: Safety distance (mm)
Minimum required distance between the surface of the sensing area and dangerous part of machine.
- K: Intrusion speed of operator's body or objects (mm/sec.)
SF2-NH□(-PN)(-H) 2,000 (mm/sec.), **SF2-NA□(-PN)(-H)** 1,600 (mm/sec.) for calculation.
- T: Response time of total equipment (sec.)
 $T = T_m + T_{SF2}$
 T_m : Maximum halt time of device (sec.)
 T_{SF2} : Response time of the **SF2-N** series 0.015 (sec.)
- C: Additional distance calculated from the size of the minimum sensing object of the sensor (mm)
Note that the value of C is not less than or equal to 0.
 $C = 8 \times (d - 14)$
d: Minimum sensing object diameter
SF2-NH□(-PN)(-H) 30 (mm) 1.181 (in)
For **SF2-NA□(-PN)(-H)**, C = 850 mm 33.465 in (constant)

For use in U.S.A. (as per ANSI B11.19)

- Equation ② $D = K \times (T_s + T_c + T_{SF2} + T_{bm}) + D_{pf}$
- D: Safety distance (mm)
Minimum required distance between the surface of the sensing area and dangerous part of machine.
- K: Intrusion speed {Recommended value in OSHA is 63 (inch/sec.) [$\approx 1,600$ (mm/sec.)]}
ANSI B11.19 does not define the intrusion speed (K). When determining K, consider possible factors including physical ability of operators.
- T_s : Halt time calculated from the operation time of the control element (air valve, etc.) (sec.)
- T_c : Maximum response time of the control circuit required for the brake to function. (sec.)
- T_{SF2} : Response time of the **SF2-N** series 0.015 (sec.)
- T_{bm} : Additional halt time tolerance for the brake monitor (sec.)
 $T_{bm} = T_a - (T_s + T_c)$
 T_a : Setting time of brake monitor (sec.)
When the machine is not equipped with a break monitor, it is recommended that 20 % or more of $(T_s + T_c)$ is taken as additional halting time.
- D_{pf} : Additional distance calculated from the size of the minimum sensing object of the sensor (mm)
SF2-NH□(-PN)(-H) $D_{pf} = 78.2$ mm 3.079 in,
SF2-NA□(-PN)(-H) $D_{pf} = 146.2$ mm 5.756 in
 $D_{pf} = 3.4 \times (d - 0.276)$ (inch)
 $D_{pf} = 3.4 \times (d - 7)$ (mm)
d: Minimum sensing object diameter 1.2 (inch) ≈ 30 (mm)
SF2-NH□(-PN)(-H)
Minimum sensing object diameter 2.0 (inch) ≈ 50 (mm)
SF2-NA□(-PN)(-H)
Note that the value of D_{pf} is not less than or equal to 0.

PRECAUTIONS FOR PROPER USE

Refer to p.1135~ for general precautions.

Influence of reflective surface



Install the sensor by considering the effect of nearby reflective surfaces and take suitable countermeasures. Failure to do so may cause the sensor not to detect, resulting in serious injury or death.

- Keep the minimum distance given below, between the sensor and a reflective surface.

Side view

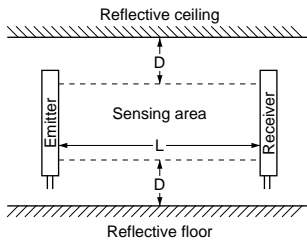

Top view

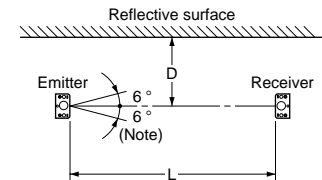

Distance between emitter and receiver, L	Allowed setting distance, D
0.3 to 3 m 0.984 to 9.843 ft	0.31 m 1.017 ft
3 to 7 m 9.843 to 22.966 ft	$L \times \tan \theta$ $\theta = 6^\circ$ $= L \times 0.105$ (m) 0.344 (ft)

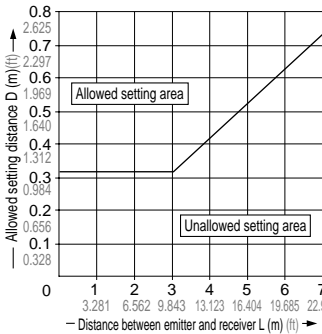

Note: The effective aperture angle for this sensor is $\pm 5^\circ$ (with $L > 3$ m 9.843 ft) as required by IEC 61496-2 / UL 61496-2. However, install this sensor away from the reflective surfaces, assuming an effective aperture angle of $\pm 6^\circ$ to provide for misalignment, etc., during installation.

Mounting

- The minimum bending radius of the cable is R30 mm R1.181 in. Mount the sensor considering the cable bending radius.

Mounting of sensor mounting bracket (MS-SF2-1/3/5)

- Choose the sensor mounting bracket based on the mounting direction (side or rear), and temporarily tighten the brackets with two M3 (length 5 mm 0.197 in) hexagon-socket-head bolts for adjusting the mounting angle. After the beam-axis alignment, tighten then bolts completely. When mounting the sensor, the tightening torque should be 0.6 N-m or less.

<Back mounting>

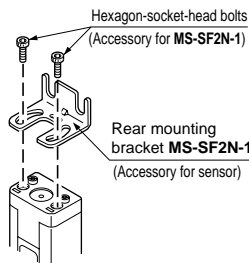

<Side mounting>

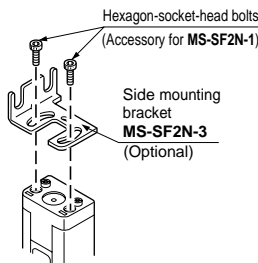

<Center sensor mounting bracket>

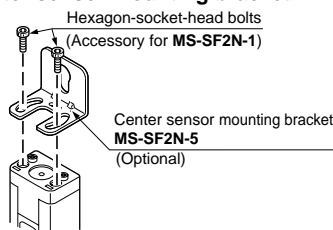

Note: Multiple beam channel sensors requiring the intermediate supporting bracket (20 mm 0.787 in beam pitch type: 36 beam channels or more, 40 mm 1.575 in beam pitch type: 18 beam channels or more) cannot be mounted on an aluminum frame with the center sensor mounting bracket (MS-SF2N-5).

Mounting of intermediate supporting bracket (MS-SF2N-2/4, MS-SF4A-H2/H4)

- ① Place the retaining plate on the U-shaped rear / side supporting bracket and temporarily tighten them with an M3 (length 10 mm 0.394 in) pan head screw.
- ② Temporarily tighten the L-shaped intermediate supporting bracket to the U-shaped rear / side supporting bracket with an M4 (length 10 mm 0.394 in) hexagon-socket-head bolt.

<Back mounting>

MS-SF2N-2 / MS-SF4A-H2

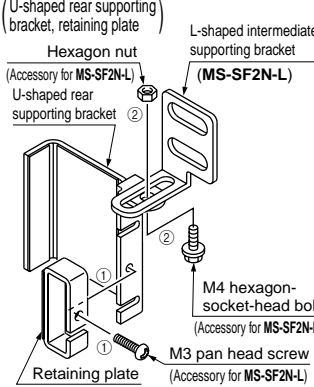

<Side mounting>

MS-SF2N-4 / MS-SF4A-H4

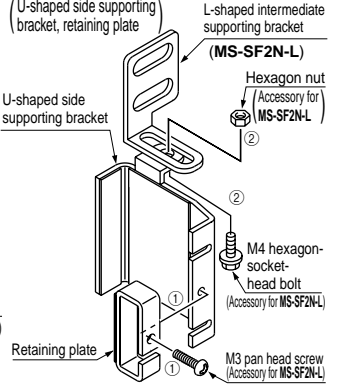

Note: The above figures are only applicable to the MS-SF2N-2/4. The MS-SF4A-H2/H4 have different shapes.

- ③ Clamp the sensor main body with the U-shaped rear / side supporting bracket and completely tighten the M3 pan head screw that secures the retaining plate. (Tightening torque: 0.4 N-m or less) After the beam-axis alignment, ensure that the M4 hexagon-socket-head bolt, which was used to temporarily attach the L-shaped intermediate supporting bracket to the U-shaped rear / side supporting bracket, is now fully tightened. (Tightening torque: 1.8 N-m or less)

<Back mounting>

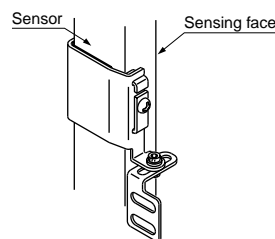

<Side mounting>

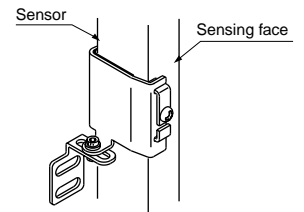

Note: The above figures show how to mount the emitter onto the intermediate supporting brackets. Note that the top and bottom orientation will be reversed when mounting the receiver to the supporting brackets.

Test input (self-diagnosis function) / Emission halt function



In order to maintain safety, carry out the self-diagnosis at least once a day.

- If the test input is kept open for 28 ms, or more, detailed diagnosis, in addition to the internal self-diagnosis being done during normal operation, is carried out. In case no abnormality is discovered during self-diagnosis, and if the test input is continued to be kept open after that, emission halt state is achieved. In case an abnormality is discovered during self-diagnosis, the device is put in the lockout state at that instant, and the control output (OSSD) and alarm outputs are fixed at the OFF state.
- Emission halt state is achieved when no abnormality is detected during self-diagnosis and the test input is continued to be kept open after that. During emission halt, control output (OSSD) and alarm output switch to the OFF state. By using this function, malfunction due to extraneous noise, or abnormality in control output (OSSD) and alarm output, can be determined even from the equipment side.

Time chart

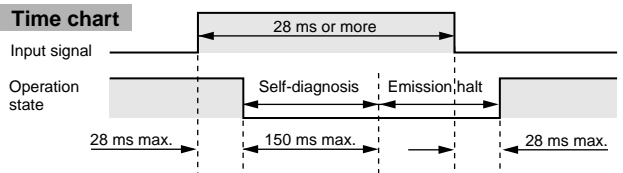

SF2-N

PRECAUTIONS FOR PROPER USE

Refer to [p.1135](#) ~ for general precautions.

Alarm output



Be sure to use the alarm output.

- Since the occurrence of a fault, such as that due to an external short-circuit, cannot be conveyed to the equipment side by control output (OSSD), the alarm output generates a warning signal. Design a system such that the equipment can be stopped when either control output (OSSD) or alarm output is output.

Time chart

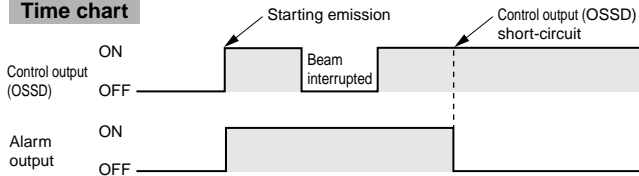

Interference prevention function

- Interference can be prevented between 3 sets max. [**SF2-NH□(-PN)(-H)**: total 128 beam channels max. **SF2-NA□(-PN)(-H)**: total 64 beam channels max.] for series connection, 2 sets max. for parallel connection, 3 sets max. for series connection and 2 sets max. parallel mixed connection. In this case, connect interference prevention output (gray) of Sensor A (master side) and test input (gray) of Sensor B (slave side).

Sensor A (master side)

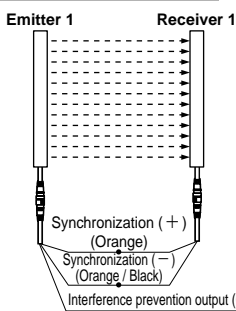

Sensor B (slave side)

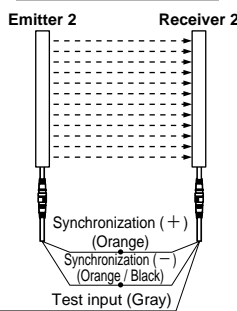

Master / slave selection input

- In case of parallel connection, or series and parallel mixed connection, before switching on the power supply, connect the master / slave selection input (violet) of Sensor A (master side), as master, to 0 V and connect the master / slave selection input (violet) of Sensor B (slave side), as slave, to open. The master / slave selection is done only once at the time of switching on of the power supply. If selection is done after switching on of the power supply, it does not change. Further if the master / slave selection input is kept open when the sensor is set as slave, ensure to insulate it.
- In case of series connection or when using 1 set, connect the master / slave selection input (violet), as master, to 0 V.

Sensor A (master side)

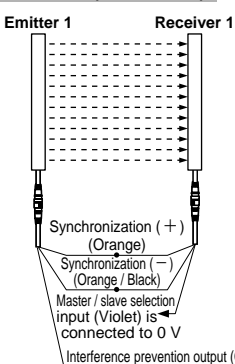

Sensor B (slave side)

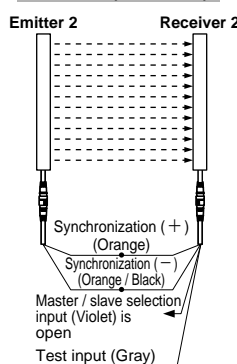

Connection

Series connection [3 sets max. (**SF2-NH□(-PN)(-H)**: 128 beam channels max., **SF2-NA□(-PN)(-H)**: 64 beam channels max.) connectable]

- When the danger region can be approached from two or more directions, multiple sets of emitters and receivers should be connected in series. When a beam of any set is interrupted, the output turns OFF.

Cable for series connection (Optional)
SF2N-CSL02 (Length: 200 mm 7.874 in)
SF2N-CSL05 (Length: 500 mm 19.685 in)

Bottom cap cable for series connection (Optional)
SF2N-CB05 (Length: 500 mm 19.685 in) (Note)

Note: Bottom cap cables for series connection are required when either 3 sets, or the total number of beam channels exceeds 48 [**SF2-NA□(-PN)(-H)**: more than 24 beam channels], are connected in series. Please note that the dimensions will change when using the bottom cap cable for series connection.

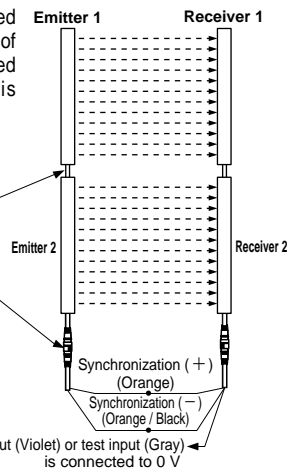

Parallel connection (2 sets max. connectable)

- To use the parallel connection method, two sets of emitters and receivers are connected in parallel. The interference prevention output (gray) from the master side must be connected to the test input (gray) from the slave side. This method can be utilized when there are two danger regions and each of them must be independently monitored. Since each output is separate from the other, if beams from only one pair of sensors are interrupted, the output from the other sensor pair remains unaffected.

Sensor A (master side)

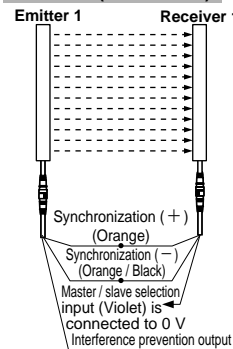

Sensor B (slave side)

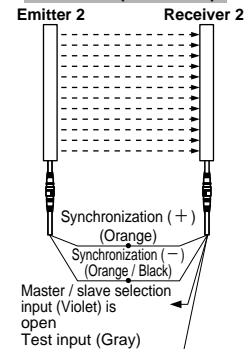

Series / Parallel mixed connection (Series connection: 3 sets, parallel connection: 2 sets connectable)

- The series / parallel mixed connection method supports the use of multiple emitters and receivers, connected in combinations of both series and parallel connections. This method can be utilized when there are two danger regions or more and when there are two entrances or more to the danger regions. For all series connections, outputs will move to the OFF state if beams for any of the beam channels are interrupted. However, as the outputs of the parallel connections are separate, if beams from any pair of parallel sensors are interrupted, outputs from all other parallel sensor pairs remain unaffected.

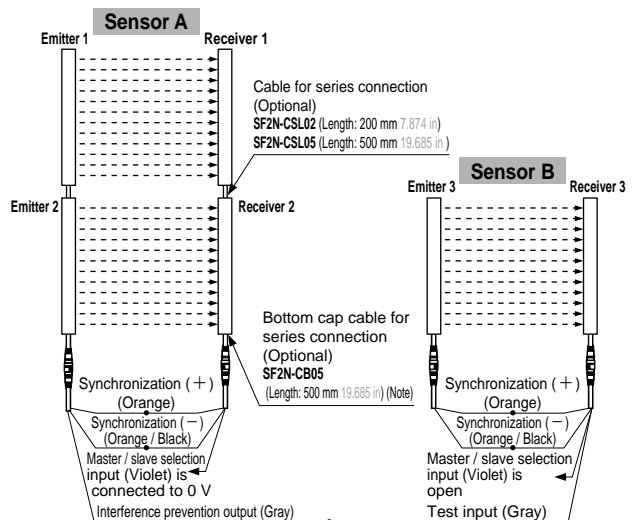

Note: Bottom cap cables for series connection are required when either 3 sets, or the total number of beam channels exceeds 48 [**SF2-NA□(-PN)(-H)**: more than 24 beam channels], are connected in series. Please note that the dimensions will change when using the bottom cap cable for series connection.

DIMENSIONS (Unit: mm in) The CAD data in the dimensions can be downloaded from the SUNX website: <http://www.sunx.co.jp/>

**SF2-NH□(-PN)
SF2-NA□(-PN)** Sensor

Assembly dimensions

Mounting drawing for the sensor on which the sensor mounting brackets and the intermediate supporting brackets are mounted.

<Back mounting>

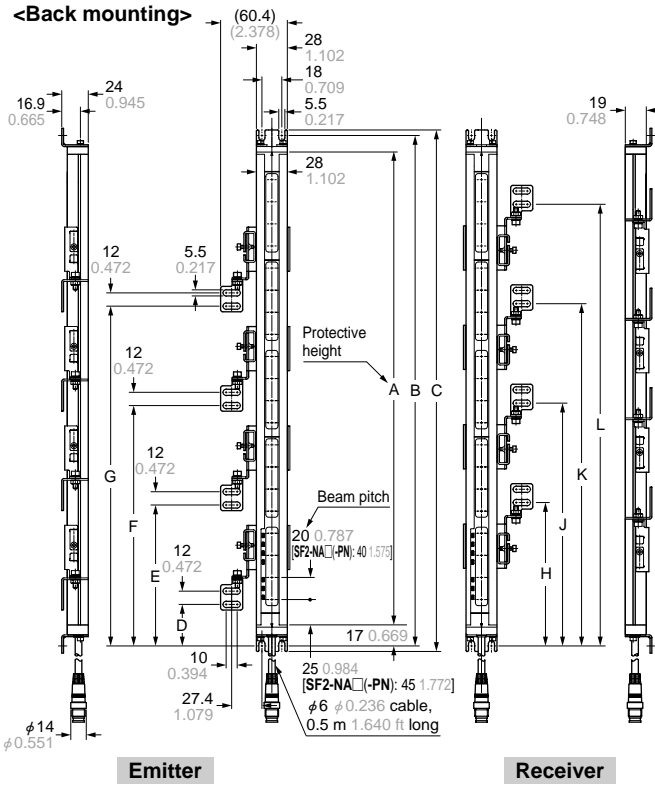

<Side mounting>

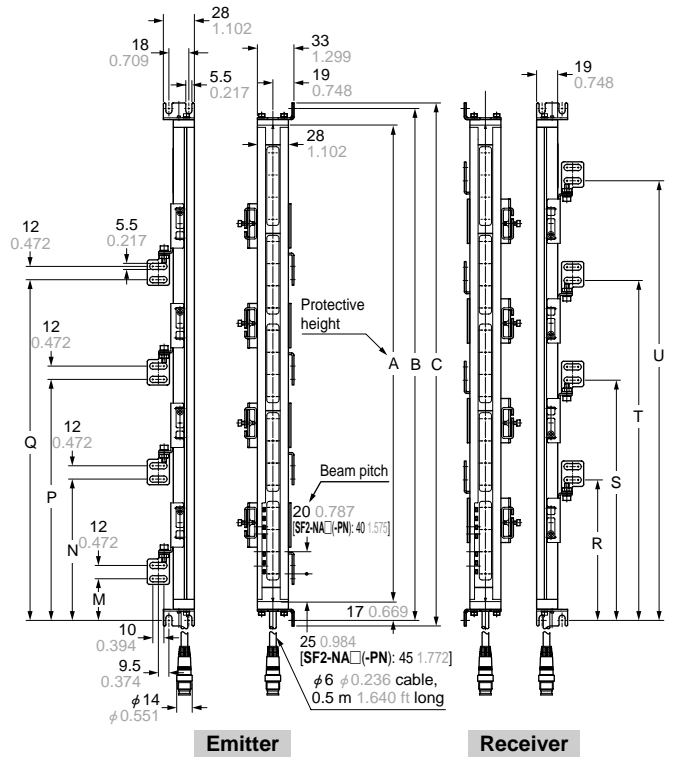

SF4-AH
SF2-A
Light Curtain
SF2-N
SF2-EH
SF-AC
Safety Relay Unit

Model No.	A	B	C	D	E	F	G	H	J	K	L
SF2-NH8(-PN)	190	222	232	—	—	—	—	—	—	—	—
SF2-NA4(-PN)	7.480	8.740	9.134	—	—	—	—	—	—	—	—
SF2-NH12(-PN)	270	302	312	—	—	—	—	—	—	—	—
SF2-NA6(-PN)	10.630	11.890	12.283	—	—	—	—	—	—	—	—
SF2-NH16(-PN)	350	382	392	—	—	—	—	—	—	—	—
SF2-NA8(-PN)	13.780	15.039	15.433	—	—	—	—	—	—	—	—
SF2-NH20(-PN)	430	462	472	—	—	—	—	—	—	—	—
SF2-NA10(-PN)	16.929	18.189	18.583	—	—	—	—	—	—	—	—
SF2-NH24(-PN)	510	542	552	—	—	—	—	—	—	—	—
SF2-NA12(-PN)	20.079	21.339	21.732	—	—	—	—	—	—	—	—
SF2-NH28(-PN)	590	622	632	—	—	—	—	—	—	—	—
SF2-NA14(-PN)	23.228	24.488	24.882	—	—	—	—	—	—	—	—
SF2-NH32(-PN)	670	702	712	—	—	—	—	—	—	—	—
SF2-NA16(-PN)	26.378	27.638	28.031	—	—	—	—	—	—	—	—
SF2-NH36(-PN)	750	782	792	337	—	—	—	433	—	—	—
SF2-NA18(-PN)	29.528	30.787	31.181	13.268	—	—	—	17.047	—	—	—
SF2-NH40(-PN)	830	862	872	377	—	—	—	473	—	—	—
SF2-NA20(-PN)	32.677	33.937	34.331	14.842	—	—	—	18.622	—	—	—
SF2-NH48(-PN)	990	1,022	1,032	377	537	—	—	473	633	—	—
SF2-NA24(-PN)	38.976	40.236	40.630	14.842	21.142	—	—	18.622	24.921	—	—
SF2-NH56(-PN)	1,150	1,182	1,192	377	537	697	—	473	633	793	—
SF2-NA28(-PN)	45.276	46.535	46.929	14.842	21.142	27.441	—	18.622	24.921	31.220	—
SF2-NH64(-PN)	1,310	1,342	1,352	457	617	777	—	553	713	873	—
SF2-NA32(-PN)	51.575	52.835	53.228	17.992	24.291	30.590	—	21.772	28.071	34.370	—
SF2-NA36(-PN)	1,470	1,502	1,512	537	697	857	—	633	793	953	—
SF2-NA40(-PN)	57.874	59.134	59.527	21.142	27.441	33.740	—	24.921	31.220	37.520	—
SF2-NA40(-PN)	1,630	1,662	1,672	537	697	857	1017	633	793	953	1,113
	64.173	65.433	65.827	21.142	27.441	33.740	40.039	24.921	31.220	37.520	43.819

Model No.	A	B	C	M	N	P	Q	R	S	T	U
SF2-NH8(-PN)	190	222	232	—	—	—	—	—	—	—	—
SF2-NA4(-PN)	7.480	8.740	9.134	—	—	—	—	—	—	—	—
SF2-NH12(-PN)	270	302	312	—	—	—	—	—	—	—	—
SF2-NA6(-PN)	10.630	11.890	12.283	—	—	—	—	—	—	—	—
SF2-NH16(-PN)	350	382	392	—	—	—	—	—	—	—	—
SF2-NA8(-PN)	13.780	15.039	15.433	—	—	—	—	—	—	—	—
SF2-NH20(-PN)	430	462	472	—	—	—	—	—	—	—	—
SF2-NA10(-PN)	16.929	18.189	18.583	—	—	—	—	—	—	—	—
SF2-NH24(-PN)	510	542	552	—	—	—	—	—	—	—	—
SF2-NA12(-PN)	20.079	21.339	21.732	—	—	—	—	—	—	—	—
SF2-NH28(-PN)	590	622	632	—	—	—	—	—	—	—	—
SF2-NA14(-PN)	23.228	24.488	24.882	—	—	—	—	—	—	—	—
SF2-NH32(-PN)	670	702	712	—	—	—	—	—	—	—	—
SF2-NA16(-PN)	26.378	27.638	28.031	—	—	—	—	—	—	—	—
SF2-NH36(-PN)	750	782	792	340	—	—	—	430	—	—	—
SF2-NA18(-PN)	29.528	30.787	31.181	13.386	—	—	—	16.929	—	—	—
SF2-NH40(-PN)	830	862	872	380	—	—	—	470	—	—	—
SF2-NA20(-PN)	32.677	33.937	34.331	14.961	—	—	—	18.504	—	—	—
SF2-NH48(-PN)	990	1,022	1,032	380	540	—	—	470	630	—	—
SF2-NA24(-PN)	38.976	40.236	40.630	14.961	21.260	—	—	18.504	24.803	—	—
SF2-NH56(-PN)	1,150	1,182	1,192	380	540	700	—	470	630	790	—
SF2-NA28(-PN)	45.276	46.535	46.929	14.961	21.260	27.559	—	18.504	24.803	31.102	—
SF2-NH64(-PN)	1,310	1,342	1,352	460	620	780	—	550	710	870	—
SF2-NA32(-PN)	51.575	52.835	53.228	18.110	24.409	30.709	—	21.654	27.953	34.252	—
SF2-NA36(-PN)	1,470	1,502	1,512	540	700	860	—	630	790	950	—
SF2-NA40(-PN)	57.874	59.134	59.527	21.260	27.559	33.858	—	24.803	31.102	37.402	—
SF2-NA40(-PN)	1,630	1,662	1,672	540	700	860	1,020	630	790	950	1,110
	64.173	65.433	65.827	21.260	27.559	33.858	40.157	24.803	31.102	37.402	43.701

SF2-N

DIMENSIONS (Unit: mm in) The CAD data in the dimensions can be downloaded from the SUNX website: <http://www.sunx.co.jp/>

SF2-NH□(-PN)-H
SF2-NA□(-PN)-H Sensor

Assembly dimensions

Mounting drawing for the sensor on which the sensor mounting brackets and the intermediate supporting brackets are mounted.

<Back mounting>

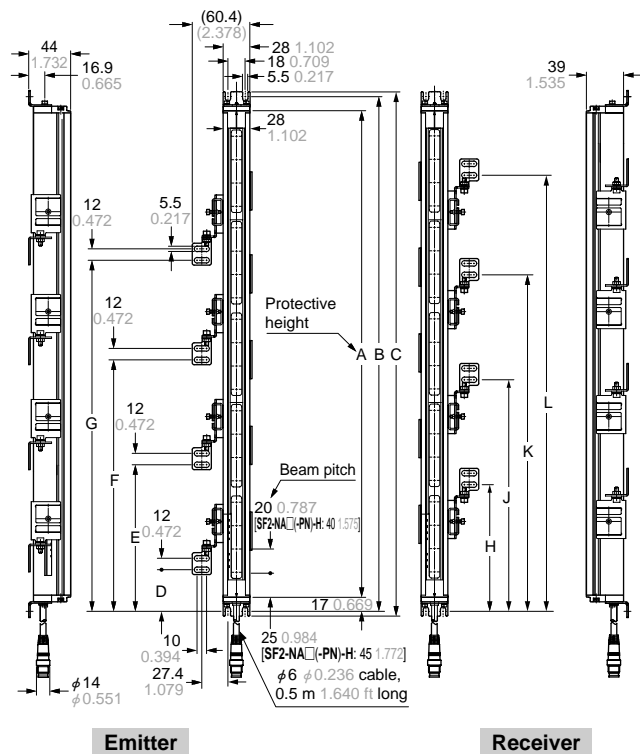

<Side mounting>

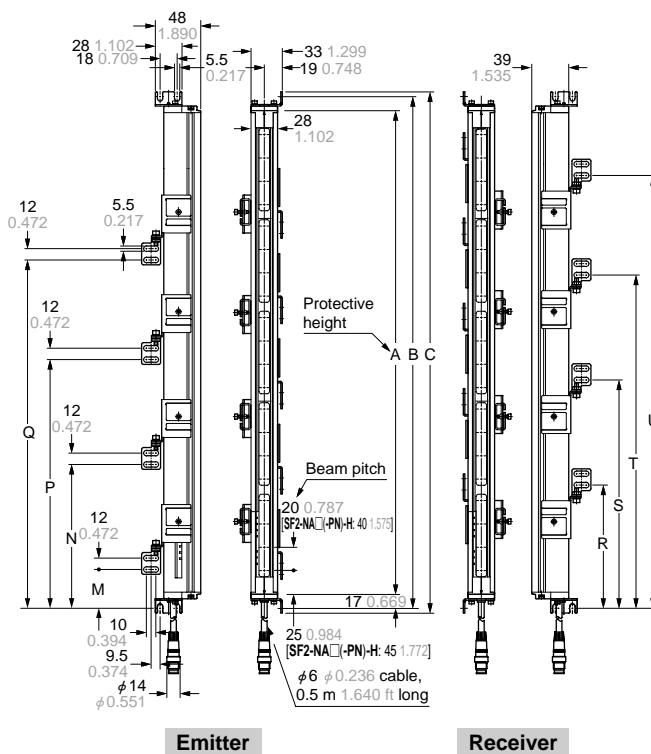

Model No.	A	B	C	D	E	F	G	H	J	K	L
SF2-NH8(-PN)-H	190	222	232								
SF2-NA4(-PN)-H	7.480	8.740	9.134								
SF2-NH12(-PN)-H	270	302	312								
SF2-NA6(-PN)-H	10.630	11.890	12.283								
SF2-NH16(-PN)-H	350	382	392								
SF2-NA8(-PN)-H	13.780	15.039	15.433								
SF2-NH20(-PN)-H	430	462	472								
SF2-NA10(-PN)-H	16.929	18.189	18.583								
SF2-NH24(-PN)-H	510	542	552								
SF2-NA12(-PN)-H	20.079	21.339	21.732								
SF2-NH28(-PN)-H	590	622	632								
SF2-NA14(-PN)-H	23.228	24.488	24.882								
SF2-NH32(-PN)-H	670	702	712								
SF2-NA16(-PN)-H	26.378	27.638	28.031								
SF2-NH36(-PN)-H	750	782	792	337				433			
SF2-NA18(-PN)-H	29.528	30.787	31.181	13.268				17.047			
SF2-NH40(-PN)-H	830	862	872	377				473			
SF2-NA20(-PN)-H	32.677	33.937	34.331	14.842				18.622			
SF2-NH48(-PN)-H	990	1,022	1,032	377	537			473	633		
SF2-NA24(-PN)-H	38.976	40.236	40.630	14.842	21.142	27.441		18.622	24.921		
SF2-NH56(-PN)-H	1,150	1,182	1,192	377	537	697		473	633	793	
SF2-NA28(-PN)-H	45.276	46.535	46.929	14.842	21.142	27.441		18.622	24.921	31.220	
SF2-NH64(-PN)-H	1,310	1,342	1,352	457	617	777		553	713	873	
SF2-NA32(-PN)-H	51.575	52.835	53.228	17.992	24.291	30.590		21.772	28.071	34.370	
SF2-NA36(-PN)-H	1,470	1,502	1,512	537	697	857		633	793	953	
	57.874	59.134	59.527	21.142	27.441	33.740		24.921	31.220	37.520	
SF2-NA40(-PN)-H	1,630	1,662	1,672	537	697	857	1017	633	793	953	1,113
	64.173	65.433	65.827	21.142	27.441	33.740	40.039	24.921	31.220	37.520	43.819

Model No.	A	B	C	M	N	P	Q	R	S	T	U
SF2-NH8(-PN)-H	190	222	232								
SF2-NA4(-PN)-H	7.480	8.740	9.134								
SF2-NH12(-PN)-H	270	302	312								
SF2-NA6(-PN)-H	10.630	11.890	12.283								
SF2-NH16(-PN)-H	350	382	392								
SF2-NA8(-PN)-H	13.780	15.039	15.433								
SF2-NH20(-PN)-H	430	462	472								
SF2-NA10(-PN)-H	16.929	18.189	18.583								
SF2-NH24(-PN)-H	510	542	552								
SF2-NA12(-PN)-H	20.079	21.339	21.732								
SF2-NH28(-PN)-H	590	622	632								
SF2-NA14(-PN)-H	23.228	24.488	24.882								
SF2-NH32(-PN)-H	670	702	712								
SF2-NA16(-PN)-H	26.378	27.638	28.031								
SF2-NH36(-PN)-H	750	782	792	340				430			
SF2-NA18(-PN)-H	29.528	30.787	31.181	13.386				16.929			
SF2-NH40(-PN)-H	830	862	872	380				470			
SF2-NA20(-PN)-H	32.677	33.937	34.331	14.961				18.504			
SF2-NH48(-PN)-H	990	1,022	1,032	380	540			470	630		
SF2-NA24(-PN)-H	38.976	40.236	40.630	14.961	21.260			18.504	24.803		
SF2-NH56(-PN)-H	1,150	1,182	1,192	380	540	700		470	630	790	
SF2-NA28(-PN)-H	45.276	46.535	46.929	14.961	21.260	27.559		18.504	24.803	31.102	
SF2-NH64(-PN)-H	1,310	1,342	1,352	460	620	780		550	710	870	
SF2-NA32(-PN)-H	51.575	52.835	53.228	18.110	24.409	30.709		21.654	27.953	34.252	
SF2-NA36(-PN)-H	1,470	1,502	1,512	540	700	860		630	790	950	
	57.874	59.134	59.527	21.260	27.559	33.858		24.803	31.102	37.402	
SF2-NA40(-PN)-H	1,630	1,662	1,672	540	700	860	1,020	630	790	950	1,110
	64.173	65.433	65.827	21.260	27.559	33.858	40.157	24.803	31.102	37.402	43.701

DIMENSIONS (Unit: mm in) The CAD data in the dimensions can be downloaded from the SUNX website: <http://www.sunx.co.jp/>

SF2-NH□(-PN)(-H)
SF2-NA□(-PN)(-H) Sensor

When using bottom cap cable for series connection

Mounting drawing for the normal case type on which bottom cap cables for series connection, the cables for series connection, the mounting brackets and intermediate supporting brackets are mounted. Dimensions of the with spatter protection hood type vary. The figure below shows dimensions identical to a normal case type.

<Back mounting>

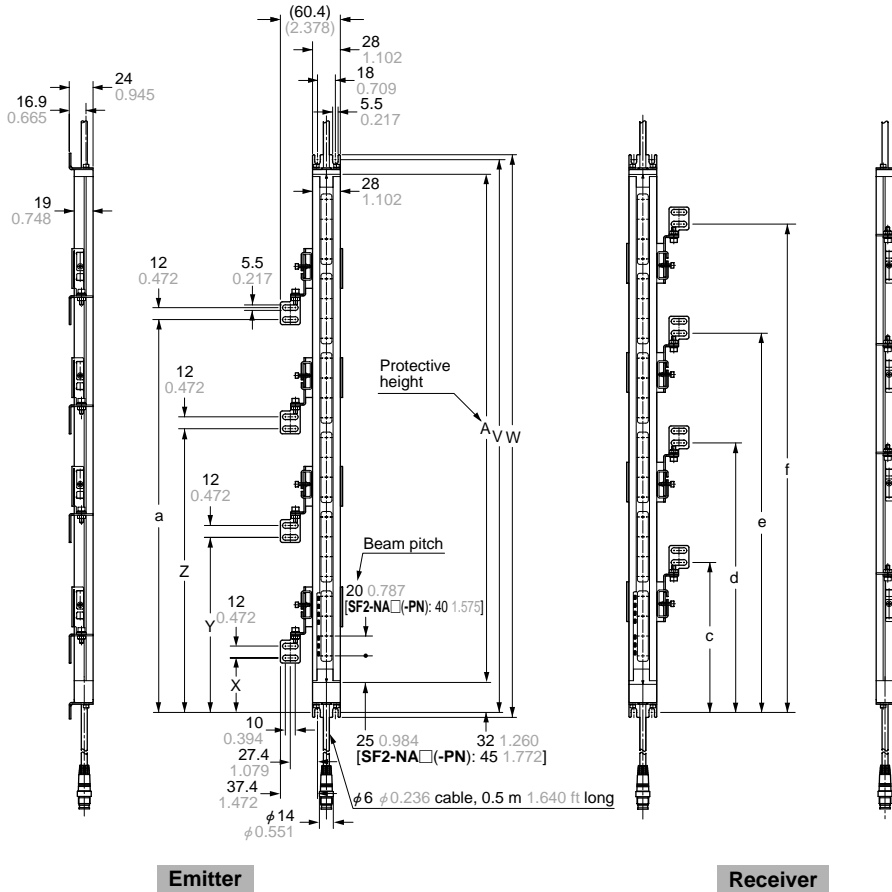

Emitter

Receiver

Model No.	A	V	W	X	Y	Z	a	c	d	e	f
SF2-NH8(-PN)(-H)	190 7.480	237 9.331	247 9.724	—	—	—	—	—	—	—	—
SF2-NH12(-PN)(-H)	270 10.630	317 12.480	327 12.874	—	—	—	—	—	—	—	—
SF2-NH16(-PN)(-H)	350 13.780	397 15.630	407 16.024	—	—	—	—	—	—	—	—
SF2-NH20(-PN)(-H)	430 16.929	477 18.779	487 19.173	—	—	—	—	—	—	—	—
SF2-NH24(-PN)(-H)	510 20.079	557 21.929	567 22.323	—	—	—	—	—	—	—	—
SF2-NH28(-PN)(-H)	590 23.228	637 25.079	647 25.472	—	—	—	—	—	—	—	—
SF2-NH32(-PN)(-H)	670 26.378	717 28.228	727 28.622	—	—	—	—	—	—	—	—
SF2-NH36(-PN)(-H)	750 29.528	797 31.378	807 31.772	345 13.583	—	—	—	441 17.362	—	—	—
SF2-NH40(-PN)(-H)	830 32.677	877 34.527	887 34.921	385 15.157	—	—	—	481 18.937	—	—	—
SF2-NH48(-PN)(-H)	990 38.976	1,037 40.827	1,047 41.220	385 15.157	545 21.457	—	—	481 18.937	641 25.236	—	—
SF2-NH56(-PN)(-H)	1,150 45.276	1,197 47.126	1,207 47.520	385 15.157	545 21.457	705 27.756	—	481 18.937	641 25.236	801 31.535	—
SF2-NH64(-PN)(-H)	1,310 51.575	1,357 53.425	1,367 53.819	465 18.307	625 24.606	785 30.905	—	561 22.087	721 28.386	881 34.685	—

Model No.	A	V	W	X	Y	Z	a	c	d	e	f
SF2-NA4(-PN)(-H)	190 7.480	237 9.331	247 9.724	—	—	—	—	—	—	—	—
SF2-NA6(-PN)(-H)	270 10.630	317 12.480	327 12.874	—	—	—	—	—	—	—	—
SF2-NA8(-PN)(-H)	350 13.780	397 15.630	407 16.024	—	—	—	—	—	—	—	—
SF2-NA10(-PN)(-H)	430 16.929	477 18.779	487 19.173	—	—	—	—	—	—	—	—
SF2-NA12(-PN)(-H)	510 20.079	557 21.929	567 22.323	—	—	—	—	—	—	—	—
SF2-NA14(-PN)(-H)	590 23.228	637 25.079	647 25.472	—	—	—	—	—	—	—	—
SF2-NA16(-PN)(-H)	670 26.378	717 28.228	727 28.622	—	—	—	—	—	—	—	—
SF2-NA18(-PN)(-H)	750 29.528	797 31.378	807 31.772	345 13.583	—	—	—	441 17.362	—	—	—
SF2-NA20(-PN)(-H)	830 32.677	877 34.527	887 34.921	385 15.157	—	—	—	481 18.937	—	—	—
SF2-NA24(-PN)(-H)	990 38.976	1,037 40.827	1,047 41.220	385 15.157	545 21.457	—	—	481 18.937	641 25.236	—	—
SF2-NA28(-PN)(-H)	1,150 45.276	1,197 47.126	1,207 47.520	385 15.157	545 21.457	705 27.756	—	481 18.937	641 25.236	801 31.535	—
SF2-NA32(-PN)(-H)	1,310 51.575	1,357 53.425	1,367 53.819	465 18.307	625 24.606	785 30.905	—	561 22.087	721 28.386	881 34.685	—
SF2-NA36(-PN)(-H)	1,470 57.874	1,517 59.724	1,527 60.118	545 21.457	705 27.756	865 34.055	—	641 25.236	801 31.535	961 37.835	—
SF2-NA40(-PN)(-H)	1,630 64.173	1,677 66.023	1,687 66.417	545 21.457	705 27.756	865 34.055	1,025 40.354	641 25.236	801 31.535	961 37.835	1,121 44.134

Safety Relay Unit
SF-AC
SF2-N
SF2-EH
SF2-A
SF4-AH

SF2-N

DIMENSIONS (Unit: mm in) The CAD data in the dimensions can be downloaded from the SUNX website: <http://www.sunx.co.jp/>

SF2-NH□(-PN)(-H)
SF2-NA□(-PN)(-H) Sensor

When using bottom cap cable for series connection

Mounting drawing for the normal case type on which bottom cap cables for series connection, the cables for series connection, the mounting brackets and intermediate supporting brackets are mounted. Dimensions of the with spatter protection hood type vary. The figure below shows dimensions identical to a normal case type.

<Side mounting>

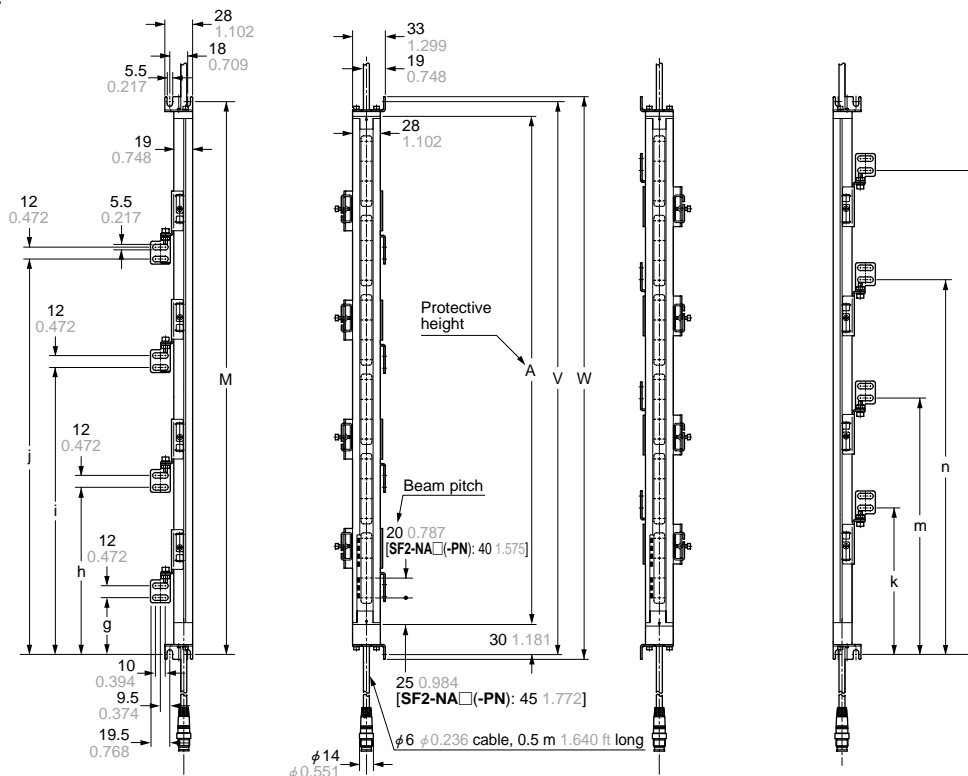

Emitter

Receiver

Model No.	A	V	W	g	h	i	j	k	m	n	p
SF2-NH8(-PN)(-H)	190 7.480	237 9.331	247 9.724	—	—	—	—	—	—	—	—
SF2-NH12(-PN)(-H)	270 10.630	317 12.480	327 12.874	—	—	—	—	—	—	—	—
SF2-NH16(-PN)(-H)	350 13.780	397 15.630	407 16.024	—	—	—	—	—	—	—	—
SF2-NH20(-PN)(-H)	430 16.929	477 18.779	487 19.173	—	—	—	—	—	—	—	—
SF2-NH24(-PN)(-H)	510 20.079	557 21.929	567 22.323	—	—	—	—	—	—	—	—
SF2-NH28(-PN)(-H)	590 23.228	637 25.079	647 25.472	—	—	—	—	—	—	—	—
SF2-NH32(-PN)(-H)	670 26.378	717 28.228	727 28.622	—	—	—	—	—	—	—	—
SF2-NH36(-PN)(-H)	750 29.528	797 31.378	807 31.772	348 13.701	—	—	—	438 17.244	—	—	—
SF2-NH40(-PN)(-H)	830 32.677	877 34.527	887 34.921	388 15.276	—	—	—	478 18.819	—	—	—
SF2-NH48(-PN)(-H)	990 38.976	1,037 40.827	1,047 41.220	388 15.276	548 21.575	—	—	478 18.819	638 25.118	—	—
SF2-NH56(-PN)(-H)	1,150 45.276	1,197 47.126	1,207 47.520	388 15.276	548 21.575	708 27.874	—	478 18.819	638 25.118	798 31.417	—
SF2-NH64(-PN)(-H)	1,310 51.575	1,357 53.425	1,367 53.819	468 18.425	628 24.724	788 31.024	—	558 21.968	718 28.268	878 34.567	—

Model No.	A	V	W	g	h	i	j	k	m	n	p
SF2-NA4(-PN)(-H)	190 7.480	237 9.331	247 9.724	—	—	—	—	—	—	—	—
SF2-NA6(-PN)(-H)	270 10.630	317 12.480	327 12.874	—	—	—	—	—	—	—	—
SF2-NA8(-PN)(-H)	350 13.780	397 15.630	407 16.024	—	—	—	—	—	—	—	—
SF2-NA10(-PN)(-H)	430 16.929	477 18.779	487 19.173	—	—	—	—	—	—	—	—
SF2-NA12(-PN)(-H)	510 20.079	557 21.929	567 22.323	—	—	—	—	—	—	—	—
SF2-NA14(-PN)(-H)	590 23.228	637 25.079	647 25.472	—	—	—	—	—	—	—	—
SF2-NA16(-PN)(-H)	670 26.378	717 28.228	727 28.622	—	—	—	—	—	—	—	—
SF2-NA18(-PN)(-H)	750 29.528	797 31.378	807 31.772	348 13.701	—	—	—	438 17.244	—	—	—
SF2-NA20(-PN)(-H)	830 32.677	877 34.527	887 34.921	388 15.276	—	—	—	478 18.819	—	—	—
SF2-NA24(-PN)(-H)	990 38.976	1,037 40.827	1,047 41.220	388 15.276	548 21.575	—	—	478 18.819	638 25.118	—	—
SF2-NA28(-PN)(-H)	1,150 45.276	1,197 47.126	1,207 47.520	388 15.276	548 21.575	708 27.874	—	478 18.819	638 25.118	798 31.417	—
SF2-NA32(-PN)(-H)	1,310 51.575	1,357 53.425	1,367 53.819	468 18.425	628 24.724	788 31.024	—	558 21.968	718 28.268	878 34.567	—
SF2-NA36(-PN)(-H)	1,470 57.874	1,517 59.724	1,527 60.118	548 21.575	708 27.874	868 34.173	—	638 25.118	798 31.417	958 37.716	—
SF2-NA40(-PN)(-H)	1,630 64.173	1,677 66.023	1,687 66.417	548 21.575	708 27.874	868 34.173	1,028 40.472	638 25.118	798 31.417	958 37.716	1,118 44.016

DIMENSIONS (Unit: mm in) The CAD data in the dimensions can be downloaded from the SUNX website: <http://www.sunx.co.jp/>

SF-AC Safety relay unit for NPN output type light curtain

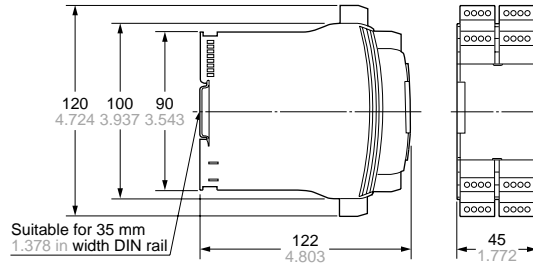

MS-SF2N-1 Rear mounting bracket (Accessory)

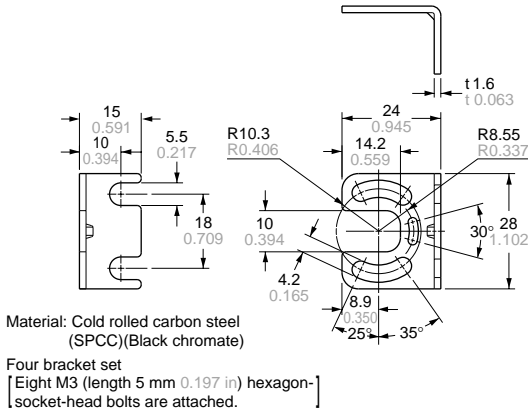

SF-IND-2 Large display unit for light curtain (Optional)

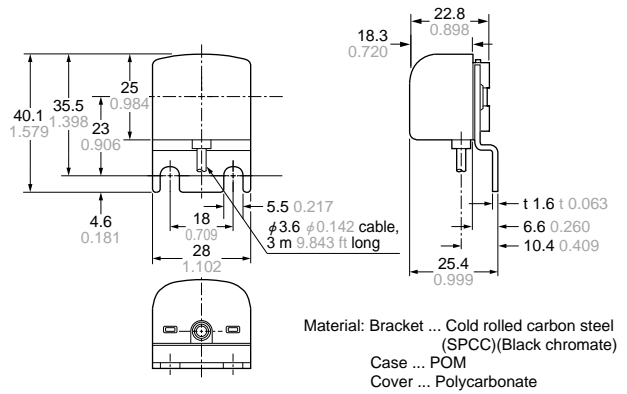

MS-SF2N-2 U-shaped rear mounting intermediate supporting bracket for the SF2-NH□/NA□(-PN) [Accessory for SF2-NH□(-PN) having 36 beam channels or more and SF2-NA□(-PN) having 18 beam channels or more]

U-shaped rear supporting bracket

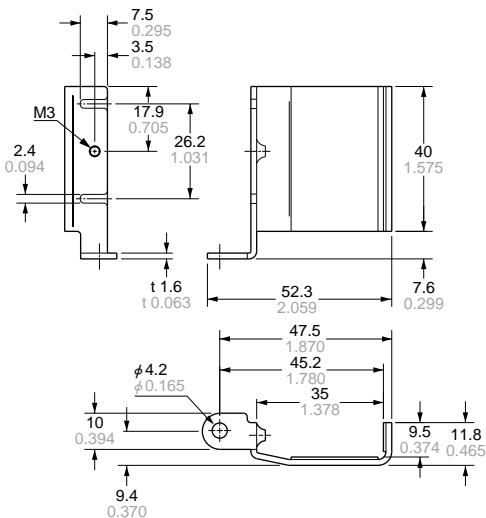

Retaining plate

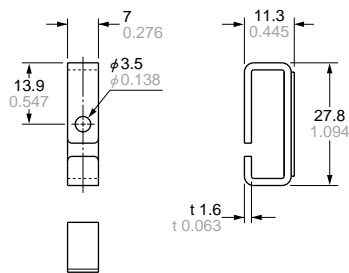

Material: Cold rolled carbon steel (SPCC)(Black chromate)

Set of 2 pcs. each of U-shaped rear supporting bracket and retaining plate (Note)

Note: **MS-SF2N-2** (U-shaped rear mounting intermediate supporting bracket) is attached with the following sensors. The number of attached U-shaped rear mounting intermediate supporting brackets is different depending on the sensor as follows.

- SF2-NH36(-PN), SF2-NH40(-PN), SF2-NA18(-PN), SF2-NA20(-PN): 1 set
- SF2-NH48(-PN), SF2-NA24(-PN): 2 sets
- SF2-NH56(-PN), SF2-NH64(-PN), SF2-NA28(-PN), SF2-NA32(-PN), SF2-NA36(-PN): 3 sets
- SF2-NA40(-PN): 4 sets

DIMENSIONS (Unit: mm in) The CAD data in the dimensions can be downloaded from the SUNX website: <http://www.sunx.co.jp/>

MS-SF4A-H2 U-shaped rear mounting intermediate supporting bracket for the SF2-NH□/NA□(-PN)-H [Accessory for SF2-NH□(-H) having 36 beam channels or more and SF2-NA□(-PN)-H having 18 beam channels or more]

U-shaped rear supporting bracket

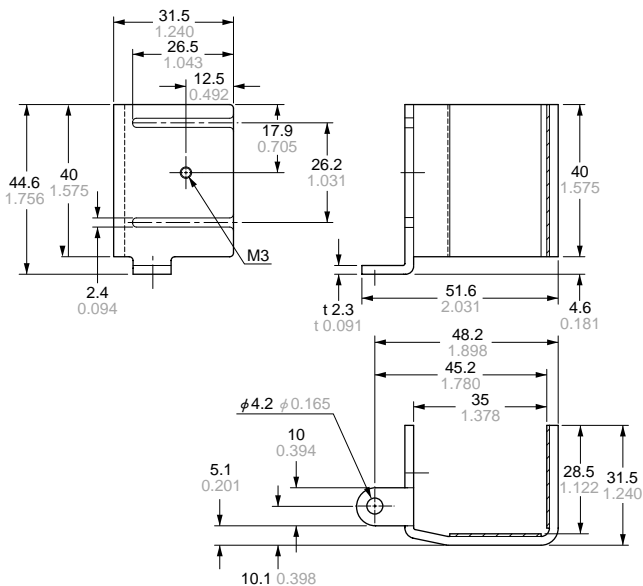

Retaining plate

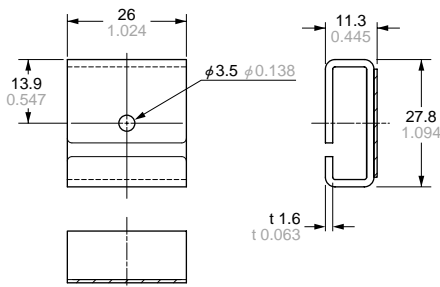

Material: Cold rolled carbon steel (SPCC)(Black chromate)
Set of 2 pcs. each of U-shaped rear supporting bracket and retaining plate (Note)

Note: MS-SF4A-H2 (U-shaped rear mounting intermediate supporting bracket) is attached with the following sensors. The number of attached U-shaped rear mounting intermediate supporting brackets is different depending on the sensor as follows.
SF2-NH36(-PN)-H, SF2-NH40(-PN)-H, SF2-NA18(-PN)-H, SF2-NA20(-PN)-H: 1 set
SF2-NH48(-PN)-H, SF2-NA24(-PN)-H : 2 sets
SF2-NH56(-PN)-H, SF2-NH64(-PN)-H, SF2-NA28(-PN)-H, SF2-NA32(-PN)-H, SF2-NA36(-PN)-H: 3 sets
SF2-NA40(-PN)-H: 4 sets

MS-SF2N-L L-shaped intermediate supporting bracket [Accessory for SF2-NH□(-PN)-H having 36 beam channels or more and SF2-NA□(-PN)-H having 18 beam channels or more]

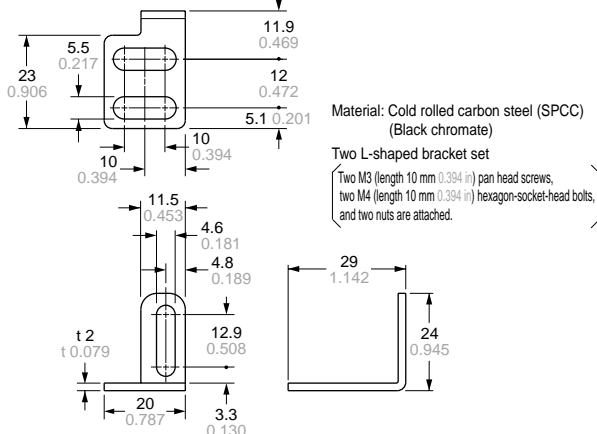

Material: Cold rolled carbon steel (SPCC) (Black chromate)

Two L-shaped bracket set
Two M3 (length 10 mm 0.394 in) pan head screws, two M4 (length 10 mm 0.394 in) hexagon-socket-head bolts, and two nuts are attached.

Note: MS-SF2N-L (L-shaped intermediate supporting bracket) is attached with the following sensors. The number of attached L-shaped intermediate supporting brackets is different depending on the sensor as follows.
SF2-NH36(-PN)-H, SF2-NH40(-PN)-H, SF2-NA18(-PN)-H, SF2-NA20(-PN)-H: 1 set
SF2-NH48(-PN)-H, SF2-NA24(-PN)-H: 2 sets
SF2-NH56(-PN)-H, SF2-NH64(-PN)-H, SF2-NA28(-PN)-H, SF2-NA32(-PN)-H, SF2-NA36(-PN)-H: 3 sets
SF2-NA40(-PN)-H: 4 sets

MS-SF2N-5 Center sensor mounting bracket (Optional)

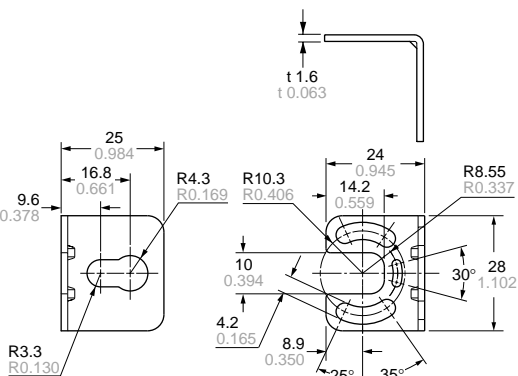

Material: Cold rolled carbon steel (SPCC)(Black chromate)
Four bracket set

MS-SF2N-3 Side mounting bracket (Optional)

Right side-mounting of sensors

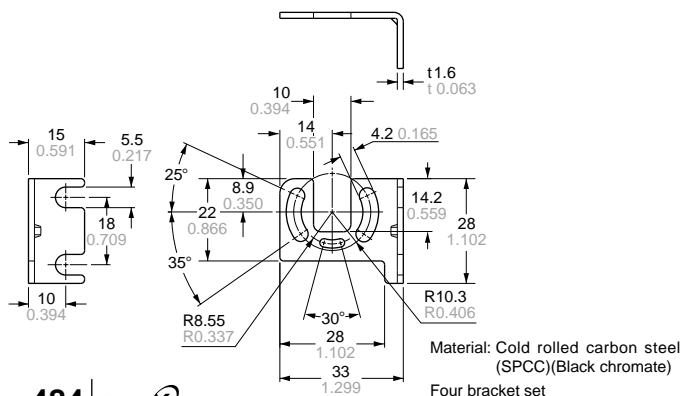

Material: Cold rolled carbon steel (SPCC)(Black chromate)
Four bracket set

Left side-mounting of sensors

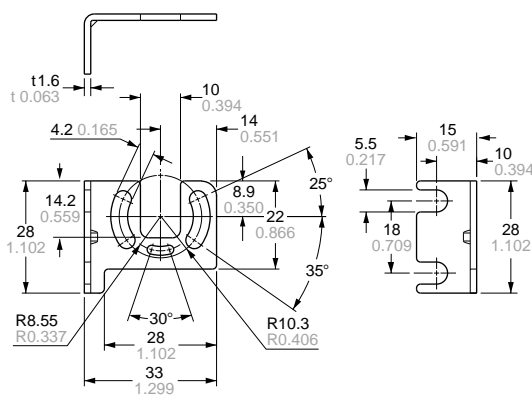

DIMENSIONS (Unit: mm in) The CAD data in the dimensions can be downloaded from the SUNX website: <http://www.sunx.co.jp/>

MS-SF2N-4 U-shaped side mounting intermediate supporting bracket for the **SF2-NH□/NA□(-PN)** (Optional)

U-shaped side supporting bracket

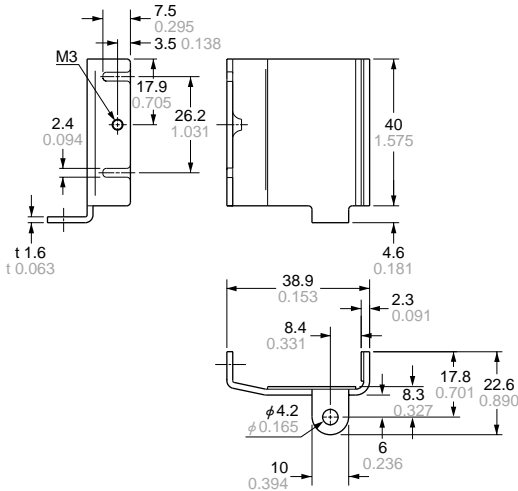

Retaining plate

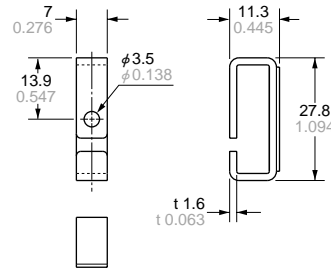

Material: Cold rolled carbon steel (SPCC)(Black chromate)
Set of 2 pcs. each of U-shaped side supporting bracket and retaining plate (Note)

Note: **MS-SF2N-4** (U-shaped side mounting intermediate supporting bracket) is attached with the following sensors. The number of attached U-shaped side mounting intermediate supporting brackets is different depending on the sensor as follows.
SF2-NH36(-PN), SF2-NH40(-PN), SF2-NA18(-PN), SF2-NA20(-PN): 1 set
SF2-NH48(-PN), SF2-NA24(-PN): 2 sets
SF2-NH56(-PN), SF2-NH64(-PN), SF2-NA28(-PN), SF2-NA32(-PN), SF2-NA36(-PN): 3 sets
SF2-NA40(-PN): 4 sets

MS-SF4A-H4 U-shaped side mounting intermediate supporting bracket for the **SF2-NH□/NA□(-PN)-H** (Optional)

U-shaped side supporting bracket

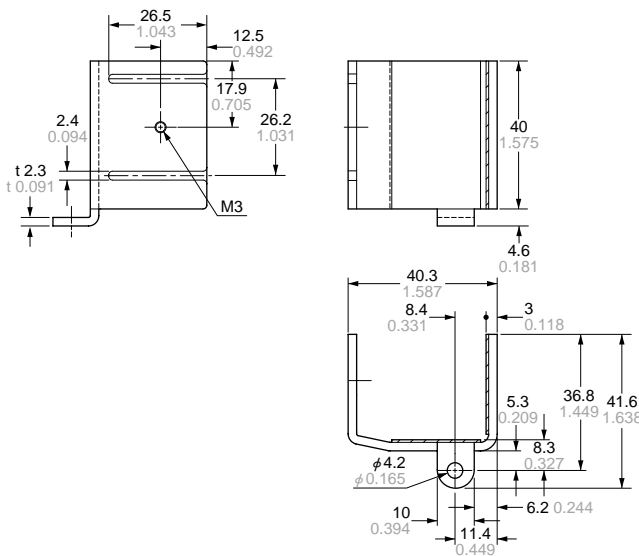

Retaining plate

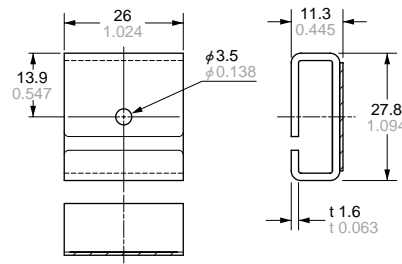

Material: Cold rolled carbon steel (SPCC)(Black chromate)
Set of 2 pcs. each of U-shaped side supporting bracket and retaining plate (Note)

Note: **MS-SF4A-H4** (U-shaped side mounting intermediate supporting bracket) is attached with the following sensors. The number of attached U-shaped side mounting intermediate supporting brackets is different depending on the sensor as follows.
SF2-NH36(-PN)-H, SF2-NH40(-PN)-H, SF2-NA18(-PN)-H, SF2-NA20(-PN)-H: 1 set
SF2-NH48(-PN)-H, SF2-NA24(-PN)-H: 2 sets
SF2-NH56(-PN)-H, SF2-NH64(-PN)-H, SF2-NA28(-PN)-H, SF2-NA32(-PN), SF2-NA36(-PN)-H: 3 sets
SF2-NA40(-PN)-H: 4 sets

Light Curtain
SF2-N
SF2-AH
SF2-A
SF2-EH
SF2-AC