

# EX-40 SERIES

Convergent Reflective Photoelectric Sensor **Amplifier Built-in**



Reliable object detection in limited area



## Stable convergent distance sensing

Due to convergent distance sensing, the color or material of the object has almost no effect. Further, the background also has very little effect, enabling stable sensing.

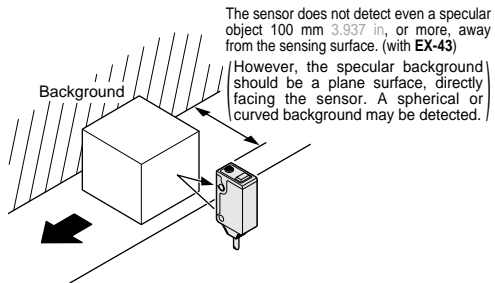

EX-43: Correlation between material and sensing range

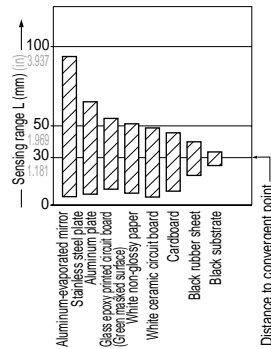

## Variable OFF-delay timer (EX-43T only)

The spot-beam type EX-43T is incorporated with an OFF-delay timer. The variable OFF-delay timer is useful for detecting a printed circuit board regardless of small holes, cutouts or electronic parts on it.

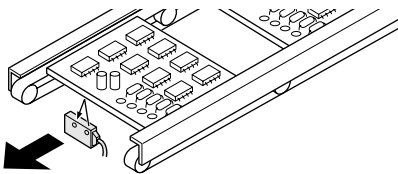

### Time chart

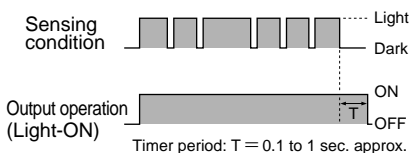

## Waterproof

Due to its IP67 construction, there is no problem even if water splashes on the sensor, as on a food processing line.

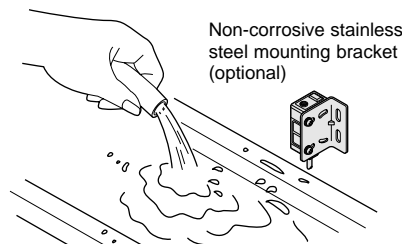

Note: However, take care that if it is exposed to water splashes during operation, it may detect a water drop itself.

Compact size (W10×H30×D18 mm W0.394×H1.181×D0.709 in)

It can be installed in a limited space.

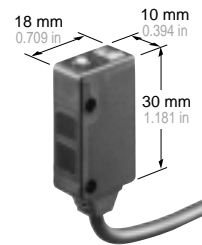

## Various applications

### Diffused beam type

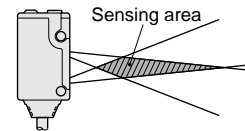

In the limited sensing area, the sensor is not affected by small perforations or unevenness. It is suitable for presence detection.

### Spot-beam type

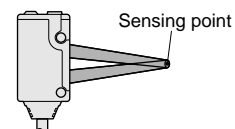

- Visible red spot beam allows easy targeting.
- It is suitable for positioning because of its 0.05 mm 0.002 in repeatability.

## APPLICATIONS

Determining PCB position

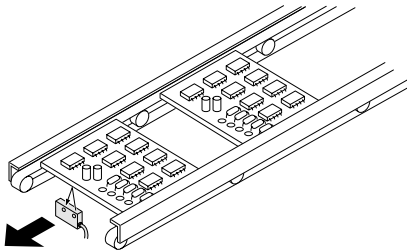

Sensing parts in feeder

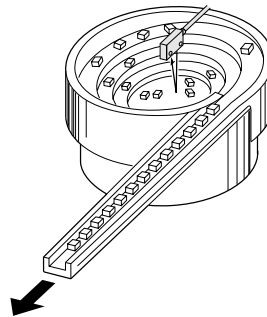

Positioning trays

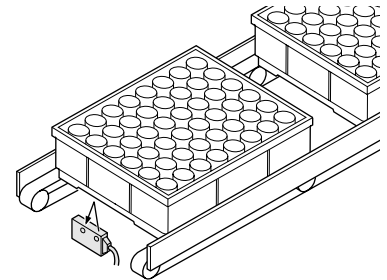

## ORDER GUIDE

Type	Appearance	Sensing range (Note 1)	Model No.	Output	Sensitivity adjuster	Timer function	Emitting element	
Diffused beam type Long sensing range		 5 to 38 mm 0.197 to 1.496 in (Convergent point: 20 mm 0.787 in)	<b>EX-42</b>	NPN open-collector transistor	—	—	Infrared LED	
		 10 to 70 mm 0.394 to 2.756 in (Convergent point: 40 mm 1.575 in)	<b>EX-44</b>					Incorporated
Spot-beam type With timer		<b>EX-43</b>	 20 to 35 mm 0.787 to 1.378 in (Convergent point: 30 mm 1.181 in)		<b>EX-43T</b>	—	Incorporated	Red LED

**NOTE: Mounting bracket is not supplied with the sensor. Please select from the range of optional sensor mounting brackets (two types).**

Note: 1) The sensor does not detect even a specular background if it is separated by the distance specified below.

**EX-42** ... 150 mm 5.906 in or more, **EX-44** ... 300 mm 11.811 in or more, **EX-43** and **EX-43T** ... 100 mm 3.937 in or more  
(These are typical values. However, the specular background should be a plane surface, directly facing the sensor.)  
(A spherical or curved background may be detected.)

### 5 m 16.404 ft cable length type

5 m 16.404 ft cable length type (standard: 2 m 6.562 ft) is also available.

### • Table of Model Nos.

Type	Standard	5 m 16.404 ft cable length type
Diffused beam type Long sensing range	<b>EX-42</b>	<b>EX-42-C5</b>
	<b>EX-44</b>	<b>EX-44-C5</b>
Spot-beam type With timer	<b>EX-43</b>	<b>EX-43-C5</b>
	<b>EX-43T</b>	<b>EX-43T-C5</b>

## EX-40

## OPTIONS

Designation	Model No.	Description	
Sensor mounting bracket	<b>MS-EX40-1</b>	Rear mounting bracket	
	<b>MS-EX40-2</b>	Bottom mounting bracket	
Universal sensor mounting stand (Note)	<b>MS-AJ1</b>	Horizontal mounting type	Basic assembly
	<b>MS-AJ2</b>	Vertical mounting type	
	<b>MS-AJ1-A</b>	Horizontal mounting type	Lateral arm assembly
	<b>MS-AJ2-A</b>	Vertical mounting type	

Note: Refer to p.332~ for details of the universal sensor mounting stand.

## Sensor mounting bracket

## • MS-EX40-1

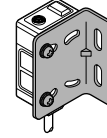

Two M3 (length 16 mm 0.630 in) screws with washers are attached.

## • MS-EX40-2

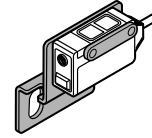

Two M3 (length 16 mm 0.630 in) screws with washers are attached.

## Universal sensor mounting stand

## • MS-AJ1

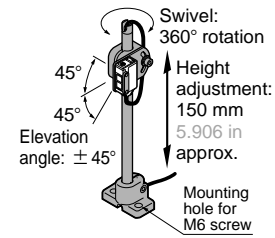

## • MS-AJ2

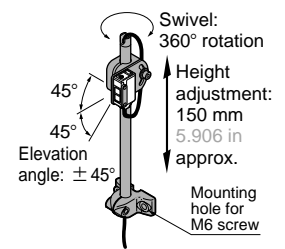

## • MS-AJ1-A

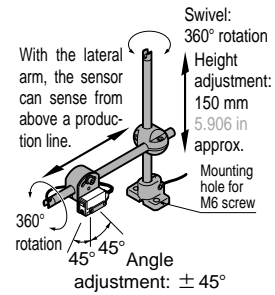

## • MS-AJ2-A

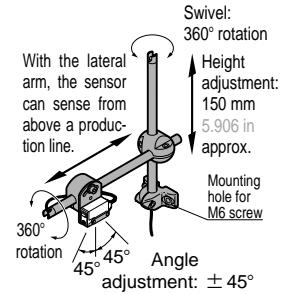

## SPECIFICATIONS

Item	Type Model No.	Diffused beam type		Spot-beam type	
		EX-42	Long sensing range EX-44	EX-43	With timer EX-43T
Sensing range		5 to 38 mm 0.197 to 1.496 in (Conv. point: 20 mm 0.787 in) with white non-glossy paper (50 X 50 mm 1.969 X 1.969 in)	10 to 70 mm 0.394 to 2.756 in (Conv. point: 40 mm 1.575 in) with white non-glossy paper (50 X 50 mm 1.969 X 1.969 in)	20 to 35 mm 0.787 to 1.378 in (Conv. point: 30 mm 1.181 in) with white non-glossy paper (50 X 50 mm 1.969 X 1.969 in)	
Min. sensing object		φ0.2 mm φ0.008 in copper wire (Setting distance: 20 mm 0.787 in)	φ0.2 mm φ0.008 in copper wire (Setting distance: 40 mm 1.575 in)	φ0.03 mm φ0.001 in gold wire (Setting distance: 30 mm 1.181 in)	
Hysteresis		15 % or less of operation distance		10 % or less of operation distance	
Repeatability (perpendicular to sensing axis)		0.1 mm 0.004 in or less (Setting distance: 20 mm 0.787 in)	0.2 mm 0.008 in or less (Setting distance: 40 mm 1.575 in)	0.05 mm 0.002 in or less (Setting distance: 30 mm 1.181 in)	
Supply voltage		12 to 24 V DC ± 10 %		Ripple P-P 10 % or less	
Current consumption		35 mA or less			
Output		NPN open-collector transistor • Maximum sink current: 100 mA • Applied voltage: 30 V DC or less (between output and 0 V) • Residual voltage: 1.5 V or less (at 100 mA sink current) 0.4 V or less (at 16 mA sink current)			
	Utilization category	DC-12 or DC-13			
	Output operation	Light-ON			
	Short-circuit protection	Incorporated			
Response time		0.5 ms or less			
Operation indicator		Red LED (lights up when the output is ON)			
Stability indicator		Green LED (lights up under stable light received condition or stable dark condition)			
Sensitivity adjuster		_____	Continuously variable adjuster	_____	
Timer function		_____			Variable OFF-delay timer (0.1 to 1 sec. approx.) (Note)
Environmental resistance	Pollution degree	3 (Industrial environment)			
	Protection	IP67 (IEC)			
	Ambient temperature	- 25 to + 55 °C - 13 to + 131 °F (No dew condensation or icing allowed), Storage: - 30 to + 70 °C - 22 to + 158 °F			
	Ambient humidity	35 to 85 % RH, Storage: 35 to 85 % RH			
	Ambient illuminance	Sunlight: 10,000 lx at the light-receiving face, Incandescent light: 3,000 lx at the light-receiving face			
	EMC	EN 50081-2, EN 50082-2, EN 60947-5-2			
	Voltage withstandability	1,000 V AC for one min. between all supply terminals connected together and enclosure			
	Insulation resistance	20 MΩ, or more, with 250 V DC megger between all supply terminals connected together and enclosure			
	Vibration resistance	10 to 500 Hz frequency, 3 mm 0.118 in amplitude (20 G max.) in X, Y and Z directions for two hours each			
Shock resistance	500 m/s <sup>2</sup> acceleration (50 G approx.) in X, Y and Z directions for three times each				
Emitting element		Infrared LED (modulated)		Red LED (modulated)	
Material		Polyalylate			
Cable		0.2 mm <sup>2</sup> 3-core cabtyre cable, 2 m 6.562 ft long			
Cable extension		Extension up to total 100 m 328.084 ft is possible with 0.3 mm <sup>2</sup> , or more, cable.			
Weight		45 g approx.			
Accessory		Adjusting screwdriver: 1pc.			

Note: The timer is always effective.

# EX-40

## I/O CIRCUIT AND WIRING DIAGRAMS

### I/O circuit diagram

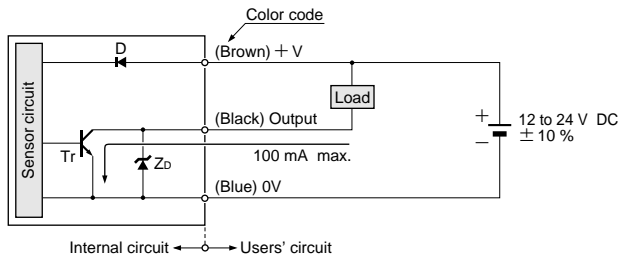

Symbols ... D : Reverse supply polarity protection diode  
 Zd: Surge absorption zener diode  
 Tr: NPN output transistor

### Wiring diagram

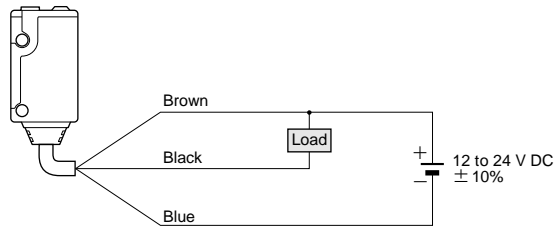

## SENSING CHARACTERISTICS (TYPICAL)

### EX-42

#### Sensing field

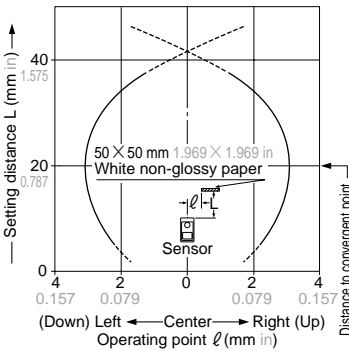

#### Correlation between sensing object size and sensing range

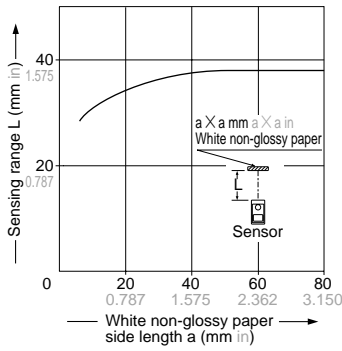

As the sensing object size becomes smaller than the standard size (white non-glossy paper 50 × 50 mm 1.969 × 1.969 in), the sensing range shortens, as shown in the left graph.

(For plotting the left graph, a sensor having a sensitivity such that it can just detect a 50 × 50 mm 1.969 × 1.969 in white non-glossy paper at a distance of 38 mm 1.496 in has been used.)

#### Correlation between lightness and sensing range

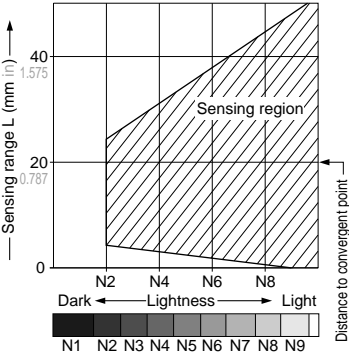

The sensing region is represented by oblique lines in the left figure. However, the sensitivity should be set with enough margin because of slight variation in products.

Lightness shown on the left may differ slightly from the actual object condition.

#### Correlation between material (50 × 50 mm 1.969 × 1.969 in) and sensing range

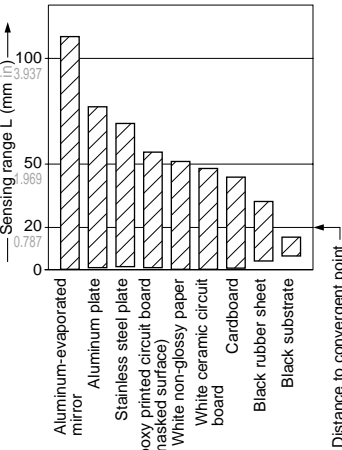

The bars in the graph indicate the sensing range for the respective material. However, there is a slight variation in the sensing range depending on the product. Further, if there is a reflective object (conveyor, etc.) in the background of the sensing object, since it affects the sensing, separate it by more than twice the sensing range shown in the left graph.

## SENSING CHARACTERISTICS (TYPICAL)

### EX-44

#### Sensing field

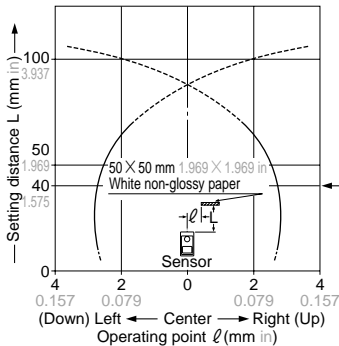

#### Correlation between sensing object size and sensing range

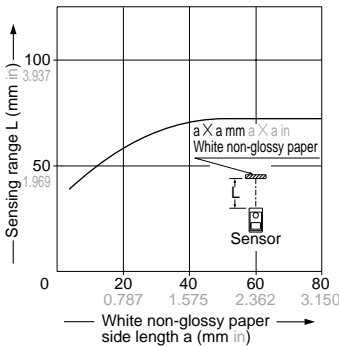

As the sensing object size becomes smaller than the standard size (white non-glossy paper 50 × 50 mm 1.969 × 1.969 in), the sensing range shortens, as shown in the left graph.

(For plotting the left graph, the sensitivity has been set such that a 50 × 50 mm 1.969 × 1.969 in white non-glossy paper is just detectable at a distance of 70 mm 2.756 in.)

#### Correlation between lightness and sensing range

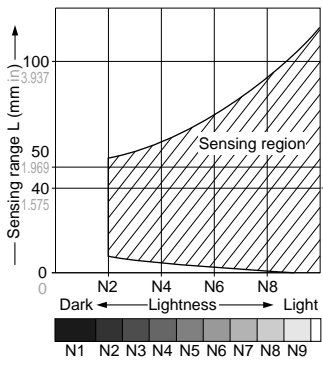

The sensing region is represented by oblique lines in the left figure. However, the sensitivity should be set with enough margin because of slight variation in products. (The graph is drawn for the maximum sensitivity setting.)

(Lightness shown on the left may differ slightly from the actual object condition.)

#### Correlation between material (50 × 50 mm 1.969 × 1.969 in) and sensing range

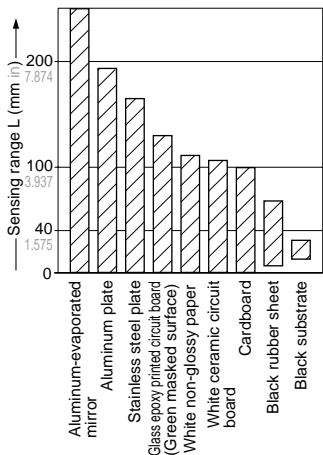

The bars in the graph indicate the sensing range for the respective material. However, there is a slight variation in the sensing range depending on the product. Further, if there is a reflective object (conveyor, etc.) in the background of the sensing object, since it affects the sensing, separate it by more than twice the sensing range shown in the left graph, or adjust the sensitivity adjuster.

(The graph is drawn for the maximum sensitivity setting.)

### EX-43 EX-43T

#### Sensing field

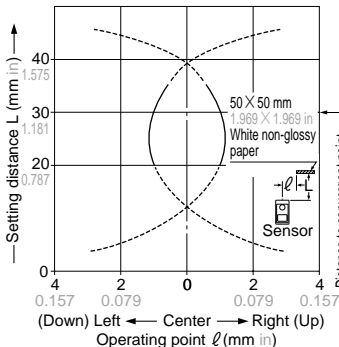

#### Correlation between lightness and sensing range

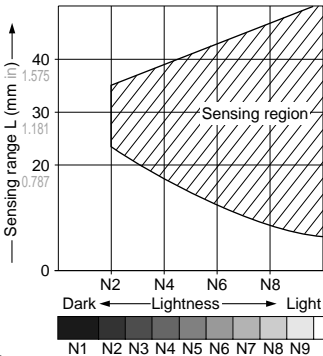

The sensing region is represented by oblique lines in the left figure. However, the sensitivity should be set with enough margin because of slight variation in products.

(The graph is drawn for the maximum sensitivity setting. However, EX-43T does not incorporate the sensitivity adjuster.)

(Lightness shown on the left may differ slightly from the actual object condition.)

#### Correlation between material (50 × 50 mm 1.969 × 1.969 in) and sensing range

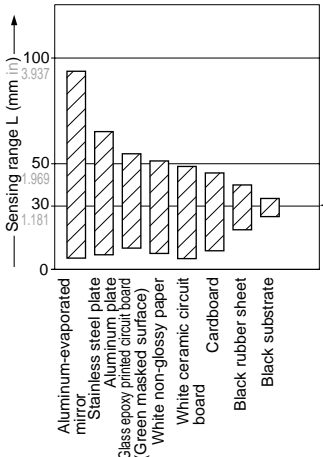

The bars in the graph indicate the sensing range for the respective material. However, there is a slight variation in the sensing range depending on the product. Further, if there is a reflective object (conveyor, etc.) in the background of the sensing object, since it affects the sensing, separate it by more than twice the sensing range shown in the left graph, or adjust the sensitivity adjuster.

(The graph is drawn for the maximum sensitivity setting. However, EX-43T does not incorporate the sensitivity adjuster.)

# EX-40

## PRECAUTIONS FOR PROPER USE

Refer to p.1135~ for general precautions.



This product is not a safety sensor. Its use is not intended or designed to protect life and prevent body injury or property damage from dangerous parts of machinery. It is a normal object detection sensor.

### Mounting

- With the optional sensor mounting bracket, the tightening torque should be 0.5 N·m or less.

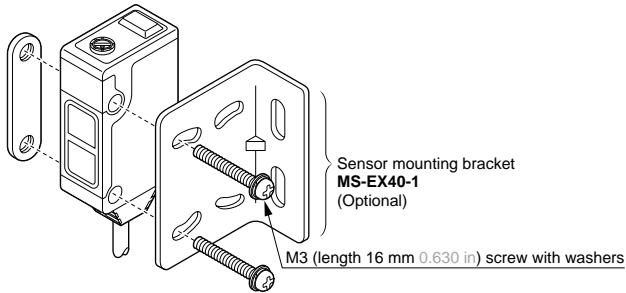

### Others

- Do not use during the initial transient time (50 ms) after the power supply is switched on.

### Timer function (Only for EX-43T)

- The variable OFF-delay timer prolongs the output for a certain period (0.1 to 1 sec. approx.). It is useful when the connected device has a slow response time or when small objects are sensed and the signal width is small.  
(The timer is always effective.)

### Adjusters

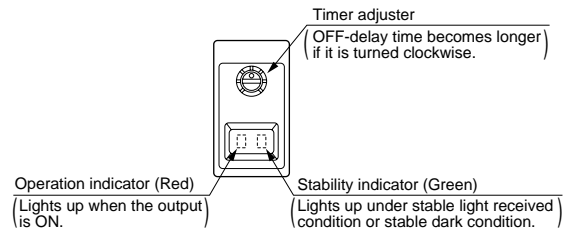

### Time chart

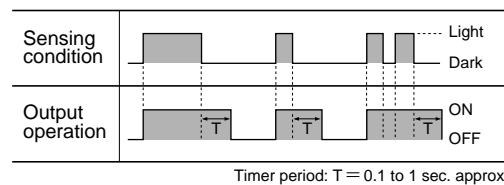





# EX-40

**DIMENSIONS (Unit: mm in)** The CAD data in the dimensions can be downloaded from the SUNX website: <http://www.sunx.co.jp/>

## MS-AJ1 Universal sensor mounting stand (Optional)

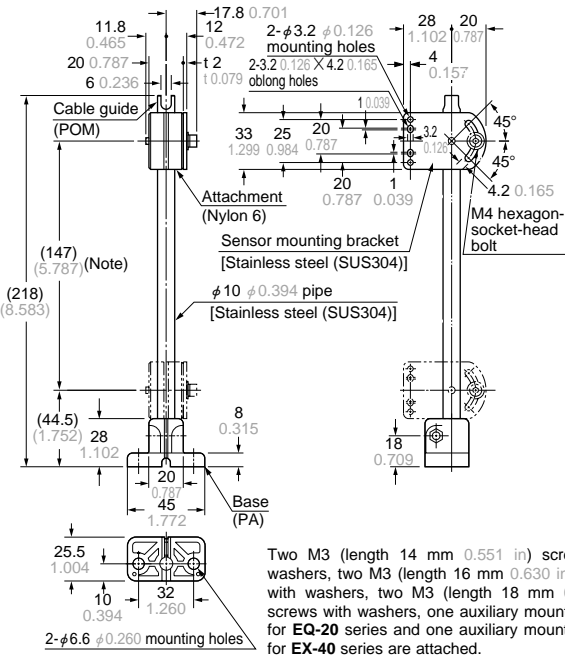

Two M3 (length 14 mm 0.551 in) screws with washers, two M3 (length 16 mm 0.630 in) screws with washers, two M3 (length 18 mm 0.709 in) screws with washers, one auxiliary mounting plate for EQ-20 series and one auxiliary mounting plate for EX-40 series are attached.

Note: The dimensions in the brackets indicate the adjustable range of the movable part.

## MS-AJ2 Universal sensor mounting stand (Optional)

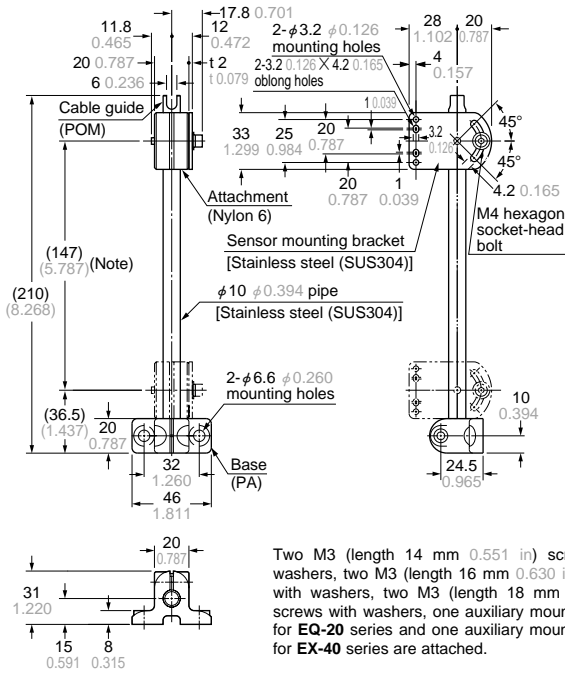

Two M3 (length 14 mm 0.551 in) screws with washers, two M3 (length 16 mm 0.630 in) screws with washers, two M3 (length 18 mm 0.709 in) screws with washers, one auxiliary mounting plate for EQ-20 series and one auxiliary mounting plate for EX-40 series are attached.

Note: The dimensions in the brackets indicate the adjustable range of the movable part.

## MS-AJ1 MS-AJ2 Universal sensor mounting stand (Optional)

### Assembly dimensions (Mounting part only)

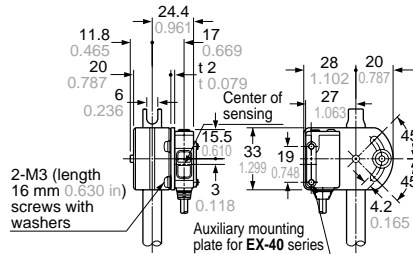

2-M3 (length 16 mm 0.630 in) screws with washers

**DIMENSIONS (Unit: mm in)** The CAD data in the dimensions can be downloaded from the SUNX website: <http://www.sunx.co.jp/>

## MS-AJ1-A Universal sensor mounting stand (Optional)

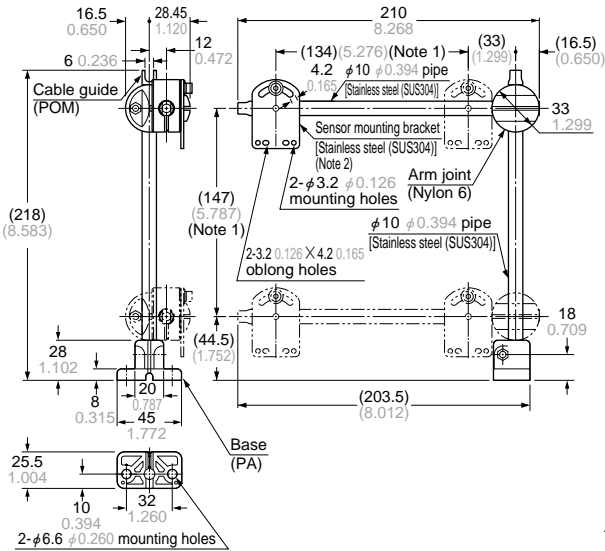

Two M3 (length 14 mm 0.551 in) screws with washers, two M3 (length 16 mm 0.630 in) screws with washers, two M3 (length 18 mm 0.709 in) screws with washers, one auxiliary mounting plate for EQ-20 series and one auxiliary mounting plate for EX-40 series are attached.

Notes: 1) The dimensions in the brackets indicate the adjustable range of the movable part.  
2) Refer to MS-AJ1/AJ2 for the assembly dimensions with the sensor mounting bracket or sensor.

## MS-AJ2-A Universal sensor mounting stand (Optional)

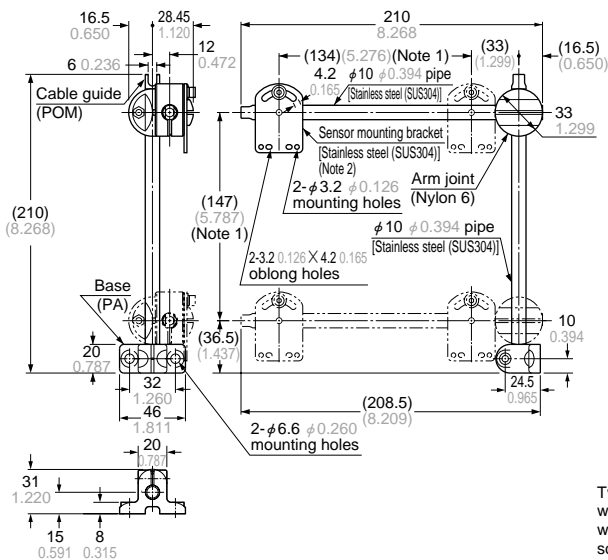

Two M3 (length 14 mm 0.551 in) screws with washers, two M3 (length 16 mm 0.630 in) screws with washers, two M3 (length 18 mm 0.709 in) screws with washers, one auxiliary mounting plate for EQ-20 series and one auxiliary mounting plate for EX-40 series are attached.

Notes: 1) The dimensions in the brackets indicate the adjustable range of the movable part.  
2) Refer to MS-AJ1/AJ2 for the assembly dimensions with the sensor mounting bracket or sensor.