



Motion Control Solutions
Minas A4/A4N/E Servo Drives/FP-Series PLCs



Panasonic Motion Control Solutions

Overview

FP-SERIES PLCs



A

MINAS A4/A4N/A4P/E SERIES SERVO DRIVES



B

SOFTWARE



C

A

FP-SERIES

The compact FPΣ (Sigma) is suitable for most applications. The FPΣ (Sigma) PLC itself has powerful features for up to two axes. Add FPΣ (Sigma) positioning units to control up to 10 independent axes. The new FP-X PLC with transistor outputs offers functionality similar to the FPΣ (Sigma). The FP2/FP2SH is also suitable for complex positioning applications, while the compact FP0 and FP-e can handle simple positioning tasks. RTEX units for FPΣ (Sigma) and FP2 offer real-time access to multiple Minas A4N drivers.

Page 3

B

MINAS A4/A4N/A4P/E SERIES SERVO MOTORS AND DRIVERS

Powerful servo drives with cutting edge technology, high power density and a power range of 50W to 5kW. [Minas A4/A4N/Minas E (100 to 400W)].

Page 11

C

SOFTWARE

Use any of the built-in functions for FPΣ (Sigma) or FP-X for up to two axes or the certified Motion Control Library for more complex tasks that require positioning units. PANATERM® and Configurator PM allow set-up, tuning, monitoring and analysis of the driven system.

Page 29

A FP-Series PLCs

Overview

PLC	FP0 / FPe	FP-X		FPΣ (Sigma)		FP2 / FP2SH
Type	Transistor	Relay with cassette	Transistor	Relay	Transistor	
Number of axes supported	2x5kHz (1x10kHz) pulse train	–	4 (2x100kHz +2x20kHz) pulse train	–	2x60kHz (1x100kHz) pulse train	–
Functions	Positioning	–	Linear interpolation 2x100kHz +2x20kHz	–	Linear interpolation 100kHz, circular 20kHz	–
Number of axes supported using expansion units	–	2x80kHz (1x100kHz) pulse train	–	8x500kHz (2MHz line driver) pulse train, 16 x Ethernet 100MHz (RTEX)	64 (88 for FP2SH) x 500kHz (2MHz line driver) pulse train, 112 x Ethernet 100MHz (RTEX)	
Number of axes per expansion unit	–	1 pulse train	–	1 or 2 pulse train, 2,4 or 8 via Ethernet (RTEX)	1 or 2 pulse train, 2, 4 or 8 via Ethernet (RTEX)	
Functions	–	Independent positioning, linear interpolation	–	Independent positioning (pulse train), linear interpolation 2 or 3 axes, circular 2 axes, spiral 3 axes (Ethernet/RTEX)		

■ FPΣ (SIGMA)



Program capacity: 32k steps
 Memory capacity: 32k words
 Expansion capacity: 4 modules (left side)
 3 modules (right side) up to 384 I/Os
 Processing speed: 0.32µs/basic instruction

■ FP-X



Program capacity: FPXC30, FPXC60 32k steps
 FPXC14 16k steps
 Memory capacity: 32k words
 Expansion capacity: Up to 8 units + up to 2 cassettes for FPXC14 or + up to 3 cassettes for FPXC30/C60
 Up to 300 I/Os possible
 Processing speed: 0.32µs/basic instructions

■ FP2 / FP2SH



Program capacity: FP2 16 or 32k steps
 FP2SH 60 or 120k steps
 Memory capacity: FP2 6000 words
 FP2SH 10,240 words
 Expansion capacity: Up to 28 modules or 2048 I/Os
 Processing speed: FP2 0.35µs/basic instruction
 FP2SH 0.03µs/basic instruction



A FP-Series PLCs

Positioning with FPΣ (Sigma)

The FPΣ (Sigma) positioning unit supports ultra-high speed linear servo motors. All-purpose device capable of linear interpolation and circular interpolation.

Pulse output of up to 4Mpps and high-speed startup at 0.005ms enable linear servo motor control.



The linear and circular interpolation functions support a wide variety of applications.

These interpolation functions enable simultaneous two-axis control, which can support applications that up to now have been difficult to handle using conventional compact PLCs.

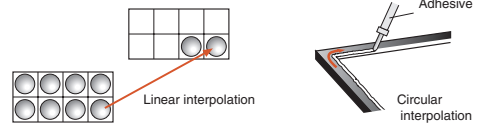

Error detection is available by using the high-speed counter in combination.

Unexpected accidents, such as errors in the driving system, can be detected by setting the counter so that it counts the feedback pulses from the encoder during positioning.

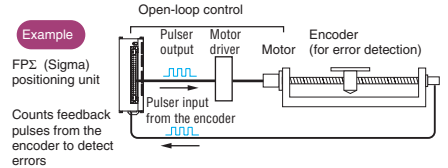

Smooth acceleration/deceleration enables smooth startup.

Accelerates/decelerates in a maximum of 60 steps depending on preset parameters

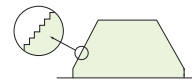

CW/CCW is also supported.

Pulse+Sign method. Cost reduction of the whole system can be achieved by using FPΣ (Sigma) with small stepping motors or servo motors that do not support the pulse-and-sign method.

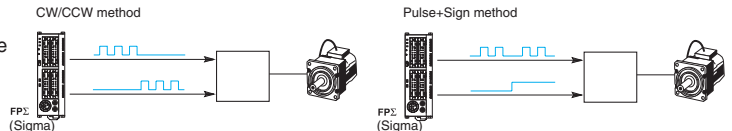

The control unit on its own can provide two-axis control.

The control unit has a pulse output of 100kpps and startup speed of 0.02ms, which provide sufficient performance for normal positioning.

Convenient and easy programming and selectable home return mode.

- Uses a data table for setting parameters, such as startup speed, target speed, acceleration/deceleration time.
- Comes with dedicated instructions for each mode: trapezoidal control, home return, JOG operation, free table operation, linear interpolation and circular interpolation.
- The home return method is selectable depending on the design, e.g. when only a single sensor is being used.
- Output of the deviation counter reset signal upon completion of return to home position is also available.

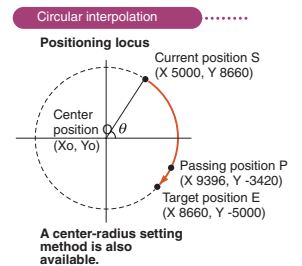

Unit type and product number

Type	Output type	Product number
1-axis type	Transistor output type	FPGPP11
2-axis type	Transistor output type	FPGPP21
1-axis type	Line driver output type	FPGPP12
2-axis type	Line driver output type	FPGPP22

Type	Output type	Product number
FPΣ (Sigma) CPU	Transistor output type NPN	FPG-C32T2H-A
FPΣ (Sigma) CPU	Transistor output type PNP	FPG-C28P2H-A

A FP-Series PLCs

Positioning with FP-X

FP-X perfectly fits the need for low cost “multi-axis positioning control in small-scale equipment”.

Built-in 4-axis pulse output (transistor output type).

The transistor output type C14 comes with 3-axis pulse output while C30/40 comes with 4-axis pulse output inside the control unit. Multi-axis control, which previously required a higher-level PLC, additional positioning unit, or two or more PLC units, can now be achieved with only one FP-X transistor output type unit in a small space at a low cost. In addition, as this type does not require a pulse I/O cassette as needed for a relay output type, other function expansion cassettes such as communication or analog input can be attached for more diversified applications.

Item	Specification
Pulse output Max. frequency	C14: 100kHz (CH0,1), 20kHz (CH2) C30, C60: 100kHz (CH0,1), 20kHz (CH2,3)
Output type	Transistor output type PNP
Function	Trapezoidal control, multi-stage operation, jog operation, origin return, 2-axis linear interpolation

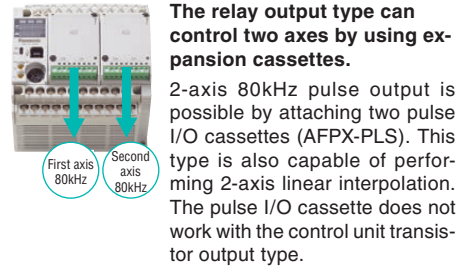
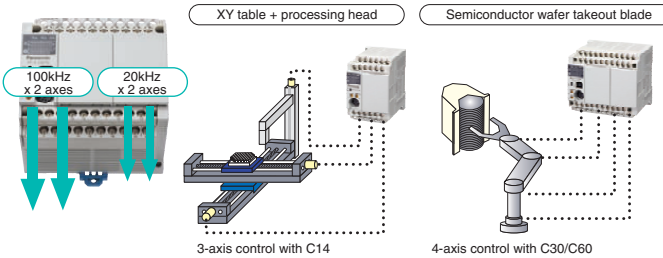

2-axis linear interpolation simultaneously in two sets (transistor output type).

2-axis linear interpolation simultaneously controls two motor shafts, allowing you, for example, to move a robot arm diagonally. It is used for palletising, component pick and place, XY table control, contour cutting of a PC board, etc. The FP-X transistor output type is capable of simultaneously controlling 2-axis linear interpolation, for the first time in the industry with a compact pulse-output PLC. This unit greatly expands the range of applications as well as providing the added convenience of programming by using the linear interpolation command F175 (SPSH).

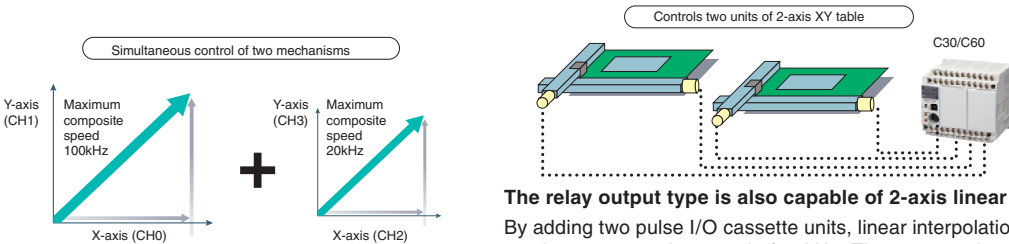

The relay output type is also capable of 2-axis linear interpolation.

By adding two pulse I/O cassette units, linear interpolation is possible at a maximum composite speed of 80kHz. The command used for this unit is F175 (SPSH) as for the transistor output types.

FP-X type overview		Power supply	Output type	In-puts	Out-puts
	AFPXC14TD	24VDC	Transistor NPN	8	6
	AFPXC14T	100 to 240VAC	Transistor NPN	8	6
	AFPXC14PD	24VDC	Transistor PNP	8	6
	AFPXC14P	100 to 240VAC	Transistor PNP	8	6
	AFPXC30TD	24VDC	Transistor NPN	16	14
	AFPXC30T	100 to 240VAC	Transistor NPN	16	14
	AFPXC30PD	24VDC	Transistor PNP	16	14
	AFPXC30P	100 to 240VAC	Transistor PNP	16	14

FP-X type overview		Power supply	Output type	In-puts	Out-puts
	AFPXC60TD	24VDC	Transistor NPN	32	28
	AFPXC60T	100 to 240VAC	Transistor NPN	32	28
	AFPXC60PD	24VDC	Transistor PNP	32	28
	AFPXC60P	100 to 240VAC	Transistor PNP	32	28



A FP-Series PLCs

FP2 and FP2SH positioning units

FEATURES

- Maximum 4Mpps command gives high-speed, high-precision positioning.
- 0.005ms high-speed drive reduces tact-time (start-up time is the time from reception of the CPU unit start-up command to release of the pulse output by the positioning unit).
- 4 axes per unit means versatility and saves space.
- S (sight-shaped) acceleration/deceleration function provides smooth starting and stopping.
- Feedback pulse count function makes output pulse counting possible for encoders, etc.
- The pulse input function allows users to generate pulses manually to adjust machines, for example.

Operation modes:

- E-point control
- P-point control
- Homing function
- Jog operation function
- Pulser input function
- Interpolation
- Single speed acceleration/deceleration
- Multistage acceleration/deceleration
- Fast startup of 0.02 or 0.005ms makes cycle time reduction possible
- Acceleration/deceleration control: Linear or 4 types of S-curve: Sine, quadratic, cycloid and cubic curves (for smooth startup and stopping)

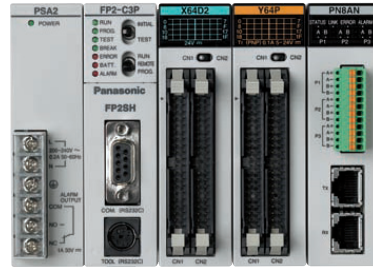

UP TO 4 AXES PER POSITIONING MODULE:

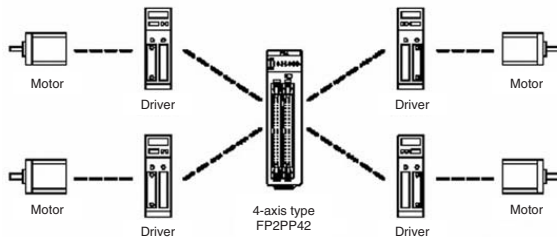

FP2 CPU types		
Type	Program capacity	Product number
FP2 Standard CPU	16k steps	FP2C1
FP2SH CPU	60k steps	FP2C2
FP2SH CPU	120k steps	FP2C3

FP2 positioning units		
Number of axes	Output type	Product number
2	Transistor	FP2PP21
2	Line driver	FP2PP22
4	Transistor	FP2PP41
4	Line driver	FP2PP42

FP2 power supplies		
Supply voltage	Power	Product number
200–240VAC	2.5A	FP2PSA2
100–240VAC	5A	FP2PSA3

FP2 backplanes	
Description	Product number
FP2 backplane 5 modules	FP2BP05
FP2 backplane 7 modules	FP2BP07
FP2 backplane 9 modules	FP2BP09
FP2 backplane 12 modules	FP2BP12
FP2 backplane 14 modules	FP2BP14

A FP-Series PLCs

RTEX positioning units for FPΣ (Sigma) and FP2/FP2SH

■ REAL-TIME ETHERNET SERVO SYSTEM FOR MINAS A4N SERVO DRIVES

Positioning units for FPΣ (Sigma) and FP2 PLCs support Minas A4N network servo drives. A mutually optimised system consisting of PLC and servo drive greatly simplifies installation.



■ ADVANTAGES:

- Easy control of network servos with an ultracompact PLC.
- Allows highly accurate control of multi-axis positioning using high-speed 100Mbps communication.
- Commercial LAN cables greatly reduce wiring costs.
- New product lineup includes a new 2-axis unit in addition to the 4-axis and 8-axis units.
- Dedicated software tool ConfiguratorPM provides total support, from configuration and startup to monitoring.
- Includes manual pulser input allowing support for precision teaching.

■ SYSTEM CONFIGURATION

No. of positioning units per RTEX unit

FPΣ (Sigma): 2 units

FP2: 14 units (limited by consumption current)

Control of 2 to 8 axes in one positioning unit

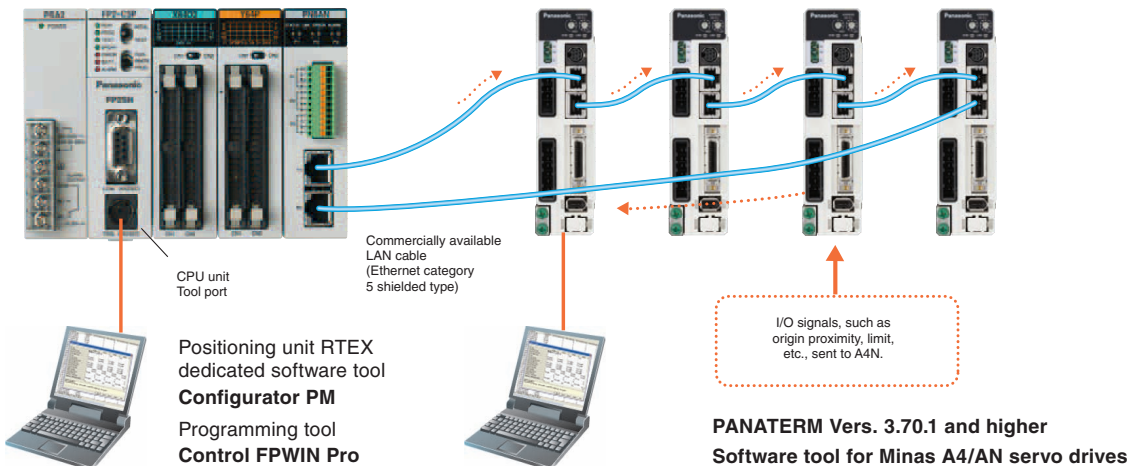



A FP-Series PLCs

RTEX multi-axis network servo system

■ FPΣ (SIGMA) POSITIONING UNIT RTEX – THE WORLD’S FIRST SERVO SYSTEM WITH ULTRACOMPACT PLC!

- Maximum number of control axes: 16 axes. Realisation of highly accurate 2-axis circular interpolation, 3-axis linear interpolation and 3-axis spiral interpolation with high-speed 100Mbps communication.
- With 3 types in the product range, for 2 axes, 4 axes and 8 axes, provides flexible support even for control of small numbers of axes.
- Provides a rich environment for total control of equipment including I/O control, with a powerful control unit with 32k step program capacity/max. 320 I/O points/serial communication on 3 ports.

FPΣ Positioning unit RTEX

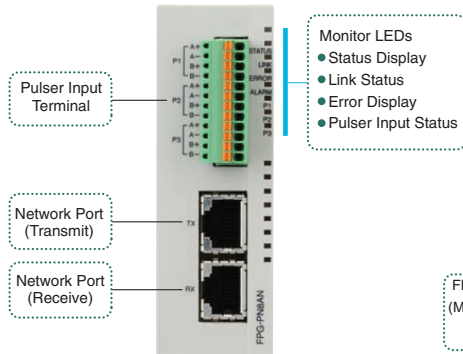

Configuration example: 16 axes + I/O (256)

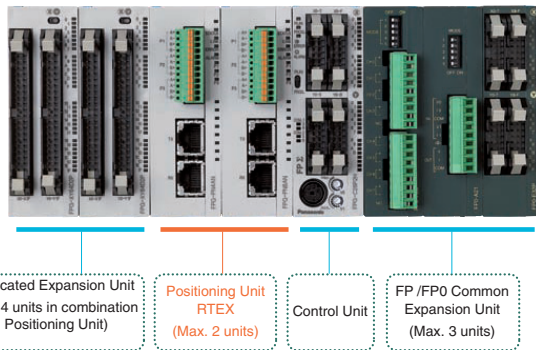

■ ULTRA-HIGHSPEED PROCESSING WITH FP2/FP2SH

- Installation of up to 14 units with 8 axes is possible bringing the number of control axes up to 112.
- With the addition of 2 axis, 4 axis and 8 axis units to the product lineup, flexible system configurations from small to large numbers of axes are possible.
- RTEX in combination with the ultra-high-speed and large capacity FP2SH CPU unit [20k steps/1ms (as measured in in-house experiments) and 120k step program capacity] provides sufficient support also for large-scale equipment.

FP2/FP2SH Positioning Unit RTEX

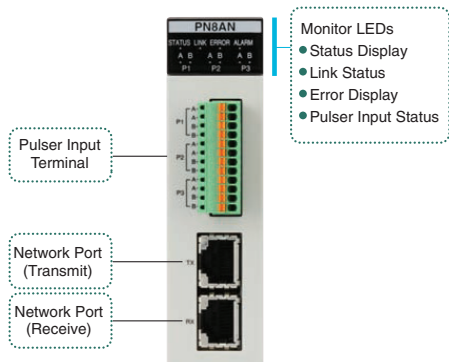

Configuration example: 8 axes x 14 modules = 112 axes

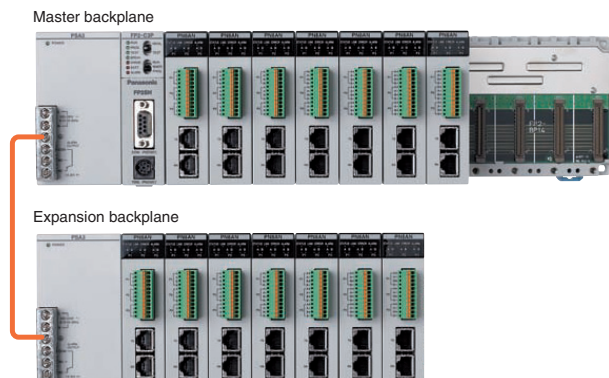

A FP-Series PLCs

RTEX multi-axis network servo system

■ BROAD REDUCTION IN WIRING COSTS

Realtime Express* uses commercially available LAN cables as wiring for its network. In terms of cost efficiency, availability and workability, this is a great benefit.

* Matsushita Electric Industrial network servo systems

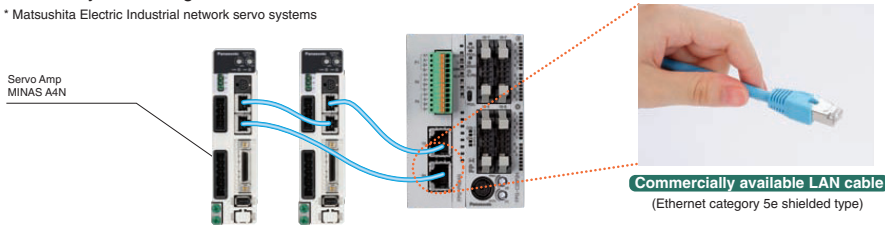

■ HIGH RELIABILITY WITH LOOP WIRING

Transmitted and received data in serial communication is normally sent and received at frequent intervals in the same cable making the communication state extremely sensitive to environmental conditions such as noise. However, by using loop wiring as shown in the figure below, Realtime Express provides high reliability by creating smooth communication conditions with the data flow always in the same direction. In addition, by utilising the 100Mbps high communication speed, Realtime Express reads the data transmissions which occur every 0.5ms twice and carries out data transfer in the extremely short period of 1ms, further improving reliability.

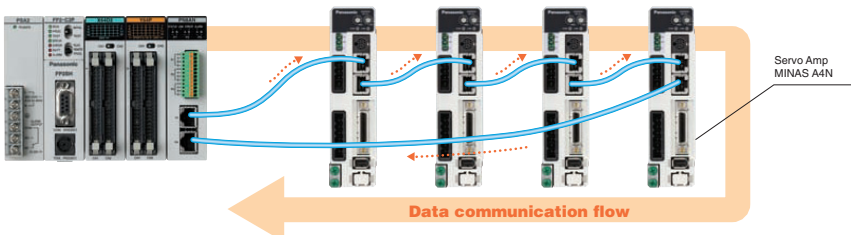

■ ADVANCED WIRING METHOD

Sensor input (origin proximity, limit) is wired directly to the servo amp of each axis and the signal is transferred through the network to the positioning unit. This enables you to check at a glance which sensor input is connected to which axis. Wiring errors are reduced and the time required for debugging shortened, especially when the system deals with large numbers of axes. In addition, even if the positioning unit and servo amp are far apart, it is not necessary to wire the signal from a sensor which is close to the servo amp to the distant positioning unit, further reducing the amount of wiring.

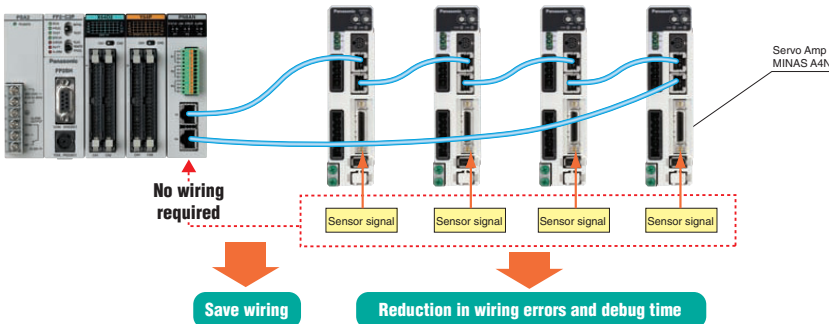



A FP-Series PLCs

RTEX multi-axis network servo system

FUNCTIONS

Operating patterns <ul style="list-style-type: none"> E-point trapezoidal control (PTP control) P-point change speed control (CP control) C-point repeated trapezoidal control (PTP control) 	Low speed test operation mode (speed setting) <ul style="list-style-type: none"> The acceleration/deceleration time and target speed for each point indicated in the data table can be set to a low speed in the range of 1 to 100% without actually changing the data itself. Test operations can be carried out safely by checking the operation of the device at low speed.
Control methods <ul style="list-style-type: none"> Absolute method, increment method 	Interpolation operation modes <ul style="list-style-type: none"> 2-axis circular, 2-axis linear 3-axis spiral, 3-axis linear
Movement unit settings <ul style="list-style-type: none"> Pulse (pulse), scale (μm, inch), angle (degree) 	Auxiliary output <ul style="list-style-type: none"> Codes can be output during operation according to the data table number.
Acceleration/deceleration method <ul style="list-style-type: none"> Linear, S-curve 	JOG operation <ul style="list-style-type: none"> Speed and acceleration/deceleration time can be changed during operation.
Origin return <ul style="list-style-type: none"> Origin proximity (DOG) search method 	Pulser input <ul style="list-style-type: none"> 2-phase quad edge – max. 1Mpps Division ratio setting possible by specification of numerator/denominator.

SPECIFICATIONS OF RTEX POSITIONING UNITS

		2-axis type		4-axis type		8-axis type		
Product number FP Σ (Sigma)/FP2		FP2PN2AN	FP2PN2AN	FP2PN4AN	FP2PN4AN	FP2PN8AN	FP2PN8AN	
Unit specifications	Positioning control functions	Control method	PTP Control, Cursor Path (CP) Control					
		Interpolation control	2-axis/3-axis linear interpolation • 2-axis circular interpolation • 3-axis spiral interpolation					
		Control units	Pulse/ μm /inch/degree					
		Position data	600 points for each axis					
		Backup	Parameters and data file can be saved to FROM					
		Acceleration/deceleration method	Linear acceleration/deceleration/S-curve acceleration/deceleration					
		Acceleration/deceleration time	0 to 10,000ms (1ms units) different settings for acceleration and deceleration are possible					
		Positioning area	(-1,073,741,823 to 1,073,741,823 pulse) increment and absolute specification					
	Speed control functions	Supported with JOG operation (free rind operation)						
	Origin functions	Search method	Origin proximity (DOG) search					
Creep speed		Free settings possible						
Other functions	Pulser input operation support							
	Auxiliary output code, auxiliary output contact support							
	Dwell time support							
	100Mbps							
Communication specifications	Communication speed	100Mbps						
	Cable	Commercially available LAN straight cable (shielded category 5e)						
	Connection method	Ring method						
	Communication cycle/no. of terminals	0.5ms: Max. 8 axes/system (command cycle: 1ms)						
	Transmission distance	Between terminals: 60m; total length: 200m						

B Minas A4/A4P/A4N/E Series Servo Drives

Main features – increased performance and accuracy



- Fast response frequency: 1000Hz (Minas E 400Hz)
- Completely adjustment-free, real-time auto-gain tuning
- High performance vibration control
- Command input up to 2Mpps
- Smaller motors and drivers versus the former series
- Position, velocity and torque control support – a wide range of applications in one driver
- Many more additional functions (Minas A4/A4N/A4P):
 - Hit & Stop homing, i.e. homing without a switch
 - Press/Tension control
 - 8 internal JOG speeds
 - Others
- Minas A4P Drivers
 - For simple positioning control. No positioning unit or pulse control necessary
 - Preset up to 60 position points with Software Tool PANATERM
 - Positioning with digital I/O

Minas series			A4	AN	A4P	A4	AN	A4P	Minas E
Rated power			50W to 5kW			400W to 7.5kW			50W to 400W
Velocity response frequency			1000Hz						400Hz
Rated/max. rotational speed			3000/5000 rpm						
Rated torque			0.16 to 15.8Nm	–	–	1.9 to 57.2Nm	–	–	0.16 to 1.3Nm
Peak torque			0.48 to 47.6Nm	–	–	5.3 to 137Nm	–	–	0.48 to 3.8Nm
Moment of inertia			0.025 to 19.7 x 10 ⁻⁴ kg m ²	–	–	2.45 to 288 x 10 ⁻⁴ kg m ²	–	–	0.021 to 0.2 x 10 ⁻⁴ kg m ²
Encoder	Incremental	Pulses	2500 pulses/rev.						
		Resolution	10,000						
	Absolute	Pulses	17-bit resolution						
		Resolution	131,072						
Control method			Pulse train	Ethernet	Digital input	Pulse train	Ethernet	Digital input	Pulse train
Control modes			Position, velocity, torque, full-closed						Position, internal speed



B Minas A4/A4N/A4P/E Series Servo Drives

Details of features

ADJUSTMENT-FREE OPERATION

E A4 A4N A4P

High-functionality real-time auto-gain tuning

- Automatically tunes in real-time to variations in load inertia. Real-time auto-gain tuning for machines with low or high stiffness.
- Supports vertical axis applications where the load torque varies depending on rotational direction.
- An over-travel detection function prevents the machine from over-travelling during real-time auto-gain tuning.
- Enables you to set and check while monitoring real-time automatic gain tuning conditions on the front panel.

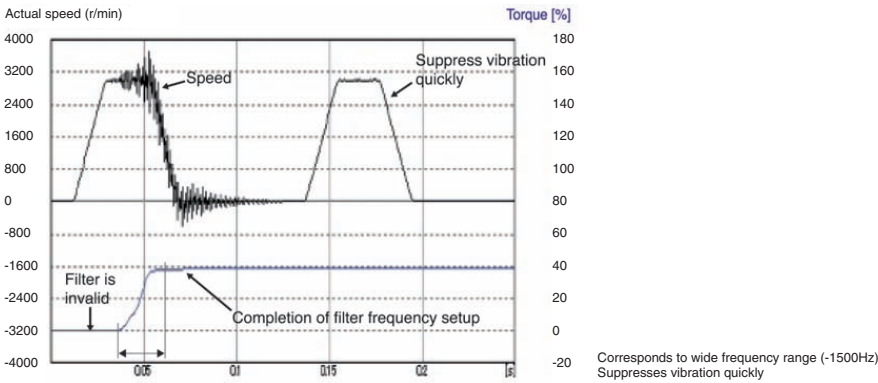

HIGH-SPEED AND FAST RESPONSE

E A4 A4N A4P

Velocity response (bandwidth) of 1kHz

- The instantaneous Velocity Observer detects the motor speed more quickly and with a higher resolution than the previous models.

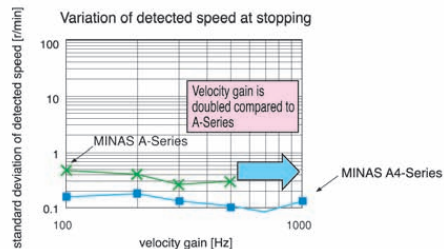
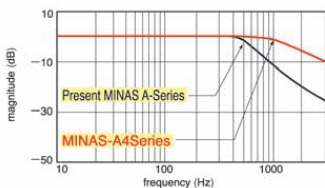

High-functionality real-time auto-gain tuning

- Enables low stiffness machines (e.g. belt-driven machines) and high stiffness machines (e.g. short stroke ball-screw driven machines) to be used in high-speed positioning applications.

Legend: not possible
 possible



B Minas A4/A4N/A4P/E Series Servo Drives

Details of features

REDUCTION VIBRATION E A4 A4N A4P

Adaptive Filter

- Enables the notch filter frequency to automatically follow the machine resonance frequency.
- Suppresses judder noise of the machine caused by a change in the resonance frequency (e.g. resulting from aging effects or changeovers).

2-CHANNEL NOTCH FILTERS E A4

Adaptive Filter

A4N A4P

- The driver is equipped with 2-channel notch filters which operate independently from the adaptive filter.
- Both frequency and width for each of the 2 filters can be set. Frequency can be defined in units of 1Hz.
- Suppress judder noise of machines with multiple resonance points.

Effect of notch filter

Without notch filter

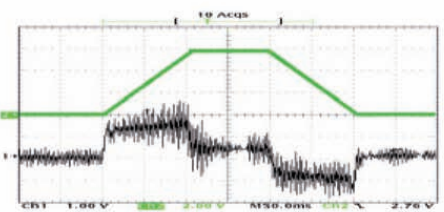

50ms/div

With notch filter

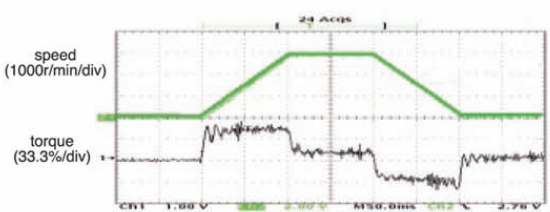

50ms/div

DAMPING CONTROL E A4 A4N A4P

- The driver is equipped with a 2-channel damping filter. You can suppress vibration occurring at both starting and stopping in low stiffness machines by manually setting up vibration frequencies in 0.1Hz units.
- You can switch between the channels with the direction command or with an external input.
- Easy setup with input of only frequency and filter values. Incorrect setup values do not result in unstable operation.

Motor movement

Machine movement

Without damping control

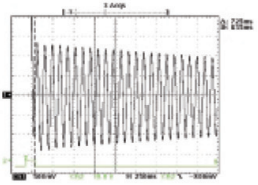
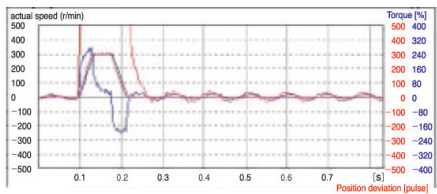

With damping control

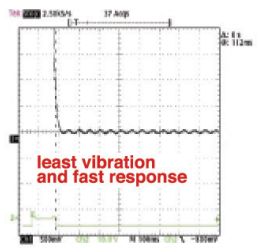
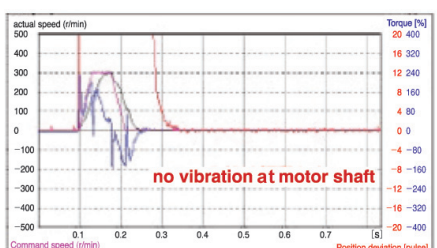

* On demand only



B Minas A4/A4N/A4P/E Series Servo Drives

Additional features

■ SETUP SUPPORT WITH HELPFUL MONITORING FUNCTIONS E A4 A4N A4P

- Faster communication speed of RS232C/RS485 (max. 57,600bps) establishes easy and comfortable operating conditions for setup support software PANATERM®.
- PANATERM® displays useful status information, e.g. to help you analyse motor problems.
- You can enable the panel operation lock via the front panel to inhibit operation, e.g. to prevent parameters from being changed unintentionally.

■ COMMAND CONTROL MODES E A4 A4N A4P

- Offers you "Position", "Velocity (including internal 8-speed)" and "Torque" command control modes.
- You can select any one of the above command control modes, or select two command control modes by defining the parameters.
- You can combine command control modes in a hybrid mode and switch between them.

■ MONITORING FUNCTION WITH FRONT PANEL E A4 A4N A4P

- LED display and analog monitor terminals are installed in the front panel.
- Displays "Motor speed", "Motor torque", "Position deviation", "Motor load factor" and "Regeneration load factor".
- You can monitor "Motor speed", "Motor torque" and "Position deviation" with analog monitor terminals.

■ TRIAL RUN (JOG) E A4 A4N A4P

- Features the function for trial run (JOG) through the front panel or console (option) without connecting to a host controller.
- Shortens machine setup time.

■ FULL-CLOSED CONTROL (HIGH PRECISION POSITIONING) E A4 A4N A4P

- Features the full-closed control of position and velocity, using the signals from the linear scale installed on the load side and the high resolution encoder.
- Best suited for high precision machines.

■ INRUSH CURRENT SUPPRESSING FUNCTION E A4 A4N A4P

- The driver is equipped with an inrush suppressing resistor which prevents circuit breaker shutdown of the power supply caused by inrush current at power-on.
- Prevents unintentional shutdown of the power supply circuit breaker in multi-axis applications and does not add load to the power line.

■ REGENERATION DISCHARGING FUNCTION E A4 A4N A4P

- Discharges regenerative energy, which is returned from the motor to the driver with a resistor, e.g. stopping a load with a large moment of inertia or with the up-down operation.
- Frame A and Frame B drivers do not have a built-in regeneration discharge resistor. We recommend connecting an optional regenerative resistor.
- Frame C – Frame F drivers have a built-in regeneration discharge resistor. However, connecting an optional regenerative resistor will add even more regenerative capability.

■ BUILT-IN DYNAMIC BRAKE E A4 A4N A4P

- The driver is equipped with a dynamic brake for emergency stop.
- The dynamic brake can be used in the following instances:
 - Main power OFF
 - Servo OFF
 - A protective function
 - Over-travel inhibit is activated

■ POSITIONING PULSE E A4 A4N A4P

- Up to 2Mpps of pulse input at positioning control possible.

■ TORQUE LIMIT VALUE SWITCHING E A4 A4N A4P

- You can set up 2 torque limits and use them for tension control or press & hold control.

■ APPROVALS E A4 A4N A4P

Legend: not possible
 possible



B Minas A4/A4N/A4P/E Series Servo Drives

Overview drivers

Rated power	Minas A4 Drivers	Minas A4N Drivers	Minas A4P Drivers	Frame Minas A4, A4N, A4P	Minas E Drivers	Frame Minas E	
50W	MADDT1205	MADDT1205N	MADDT1205P	A	MKDET1505P	K	
100W					MLDET2210P		
200W	MADDT1207	MADDT1207N	MADDT1207P		B	MLDET2510P	L
400W	MBDDT2210	MBDDT2210N	MBDDT2210P				
750W	MCDDT3520	MCDDT3520N	MCDDT3520P	C	–	–	
1kW	MDDDT5540	MDDDT5540N	MDDDT5540P	D	–	–	
1.5kW				–	–		
2kW	MEDDT7364	MEDDT7364N	MEDDT7364P	E	–	–	
3kW	MFDDTA390	MFDDTA390N	MFDDTA390P	F	–	–	
4kW	MFDDTB3A2	MFDDTB3A2N	MFDDTB3A2P		–	–	
5kW	–	–	–		–	–	







Minas A4/A4N/A4P				
Basic specifications	Input power	Main circuit	Frame A, B Single phase, 200–240V +10% -15% 50/60Hz Frame C, D Single/3-phase, 200–240V +10% -15% 50/60Hz Frame E, F Single/3-phase, 200–240V +10% -15% 50/60Hz	
		Control circuit	Frame A to D Single phase, 200–240V +10% -15% 50/60Hz Frame E, F Single phase, 200–230V +10% -15% 50/60Hz	
		Environment	Temperature	Operating: 0 to 55°C, Storage: -20 to +80°C
			Humidity	Both operating and storage : 90%RH or less (free from condensation)
			Altitude	1000m or lower
Vibration	5.88m/s ² or less, 10 to 60Hz (no continuous use at resonance frequency)			
Control method	IGBT PWM sinusoidal wave drive			
Encoder feedback	17-bit (131,072 resolution) absolute/incremental encoder (on demand only) 2500P/r (10,000 resolution) incremental encoder (standard)			
External scale feedback	Compatible with AT500 series, ST771 by Mitsutoyo			
Control signal	Input	10 inputs (1) Servo-ON, (2) Control mode switching, (3) Gain switching/torque limit switching, (4) Alarm clear other inputs vary depending on the control mode, (5) CW drive prohibition, (6) CCW driver prohibition		
	Output	6 outputs (1) Servo alarm, (2) Servo ready, (3) Release signal of external brake (4) Zero speed detection, (5) Torque in-limit. Other outputs vary depending on the control mode		
Analog signal	Input	3 inputs (16Bit A/D : 1 input, 10Bit A/D : 2 inputs)		
	Output	2 outputs (for monitoring) (1) Speed monitor (actual motor speed or command speed). Select the content and scale with parameter. (2) Torque monitor [torque command (approx. 3V/rated torque)], deviation counter or full-closed deviation is enabled. Select the content or scale with parameter		
Pulse signal	Input	2 inputs. Select the exclusive input for line driver or photo-coupler input with parameter		
	Output	4 outputs. Feed out the encoder pulse (A, B and Z-phase) or external scale pulse (EXA, EXB and EXZ-phase) in line driver. Z-phase and EXZ-phase pulse is also fed out in open collector		
Communication function	RS232C	1:1 communication to a host with RS232C interface is enabled		
	RS485	1:n communication up to 15 axes to a host with RS485 interface is enabled		
Front panel	(1) 5 keys (MODE, SET, UP, DOWN, SHIFT), (2) LED (6-digit)			
Regeneration	Frame A, B: no built-in regenerative resistor (external resistor only), Frame C to F: built-in regenerative resistor (external resistor is also enabled)			
Dynamic brake	Setup of action sequence at power-OFF, servo-OFF, at protective function activation and over-travel inhibit input is enabled			
Control mode	Switching among the following 7 modes is enabled, (1) Position control, (2) Velocity control, (3) Torque control, (4) Position/Velocity control, (5) Position/Torque control, (6) Velocity/Torque control and (7) Full-closed control			



B Minas A4/A4N/A4P Series Servo Drives

Common driver specifications

Analog functions	Position control	Control input	(1) Deviation counter clear, (2) Command pulse inhibition, (3) Electronic gear switching, (4) Damping control switching	
		Control output	Positioning complete (In-position)	
		Pulse input	Max. command pulse frequency	Exclusive interface for line driver: 2Mpps, Line driver: 500kpps, Open collector: 200kpps
			Input pulse signal format	Support (1) RS422 line drive signal and (2) Open collector signal from controller
			Type of input pulse	Differential input. Selectable with parameter, [(1) CW/CCW, (2) A and B-phase, (3) Command and Direction]
			Electronic gear (division/multiplication of command pulse)	Process the command pulse frequency $\times \frac{(1 \text{ to } 10,000) \times 2^{(n-17)}}{1 \text{ to } 10,000}$ as a position command input
			Smoothing filter	Primary delay filter or FIR type filter is selectable to the command input
		Analog input	Torque limit command input	Individual torque limit for both CW and CCW direction is enabled (3V/rated torque)
		Instantaneous speed observer	Usable	
		Damping control	Usable	
	Velocity control	Control input	(1) Zero speed clamp, (2) Selection of internal speed setup, (3) Gain switching or torque limit switching input	
		Control output	Speed arrival (at-speed)	
		Analog input	Velocity command input	Setup of scale and rotational direction of the motor against the command voltage is enabled with parameter, with the permissible max. voltage input = 10V and 6V/rated speed (default setup)
			Torque limit command input	Individual torque limit for both CW and CCW direction is enabled (3V/rated torque)
		Speed control range	1 : 5000	
		Internal speed command	8-speed with parameter setup	
		Soft-start/down function	Individual setup of acceleration and deceleration is enabled, with 0 to 10s/1000r/min. Sinusoidal acceleration/deceleration is also enabled	
		Zero speed clamp	Zero speed clamp for internal speed command	
		Instantaneous speed observer	Usable	
		Speed command filter	Usable	
	Torque control	Control input	(1) CW over-travel inhibition, (2) CCW over-travel inhibition, (3) Zero speed clamp	
		Control output	Speed arrival (at-speed)	
		Analog input	Speed command input	Setup of scale and CW/CCW torque generating direction of the motor against the command voltage is enabled with parameter, with the permissible max. voltage input = 10V and 3V/rated speed (default setup)
			Speed limit input	Speed limit input by analog voltage is enabled. Scale setup with parameter
Speed limit function	Speed limit value with parameter or analog input is enabled			
Full-closed control	Control input	(1) CW over-travel inhibition, (2) CCW over-travel inhibition, (3) Deviation counter clear, (4) Command pulse input inhibition, (5) Electronic gear switching, (6) Damping control switching		
	Control output	Full-closed positioning complete (in-position)		
	Pulse input	Max. command pulse frequency	Exclusive interface for line driver: 2Mpps, Line driver: 500kpps, Open collector : 200kpps	
		Input pulse signal format	Differential input. Selectable with parameter (1) CCW/CW, (2) A and B-phase, (3) Command and direction	
		Electronic gear division/multiplication of command pulse	Process the command pulse frequency $\times \frac{(1 \text{ to } 10,000) \times 2^{(n-17)}}{1 \text{ to } 10,000}$ as a position command input	
		Smoothing filter	Primary delay filter is adaptable to the command input	
	Analog input	Torque limit command input	Individual torque limit for both CW and CCW direction is enabled (3V/rated torque)	
Setup range of division/multiplication of external scale	Setting of ratio between encoder pulse (denominator) and external scale pulse (numerator) is enabled within a range of (1 to 10,000) $\times 2^{(0-17)}$ / (1 to 10,000)			
Common	Auto-gain tuning	Real-time	Corresponds to load inertia fluctuation, possible to automatically set up parameters related to notch filter	
		Normal mode	Estimates load inertia and sets up an appropriate servo gain	
		Fit-gain function	Automatically searches and sets up the value which makes the fastest settling time with external command input	
	Masking of unnecessary input	Masking of the following input signal is enabled (1) Over-travel inhibition, (2) Torque limit, (3) Command pulse inhibition, (4) Speed-zero clamp		
	Division of encoder feedback pulse	Set up of any value is enabled (encoder pulses count is the max.)		
	Protective function	Soft error	Over-voltage, under-voltage, over-speed, over-load, over-heat, over-current and encoder error etc.	
		Hard error	Excess position deviation, command pulse division error, EEPROM error etc.	
	Traceability of alarm data	Traceable up to past 14 alarms including the present one		
	Damping control function	Manual setup with parameter		
	Setup	Manual	5-push switches on front panel     	
Setup support software		PANATERM® (Supporting OS: Windows95, Windows98, Windows ME, Windows2000, Windows.NET and Windows XP)		



B Minas E Series Servo Drives

Driver dimensions

■ FRAME K

MKDET1505P

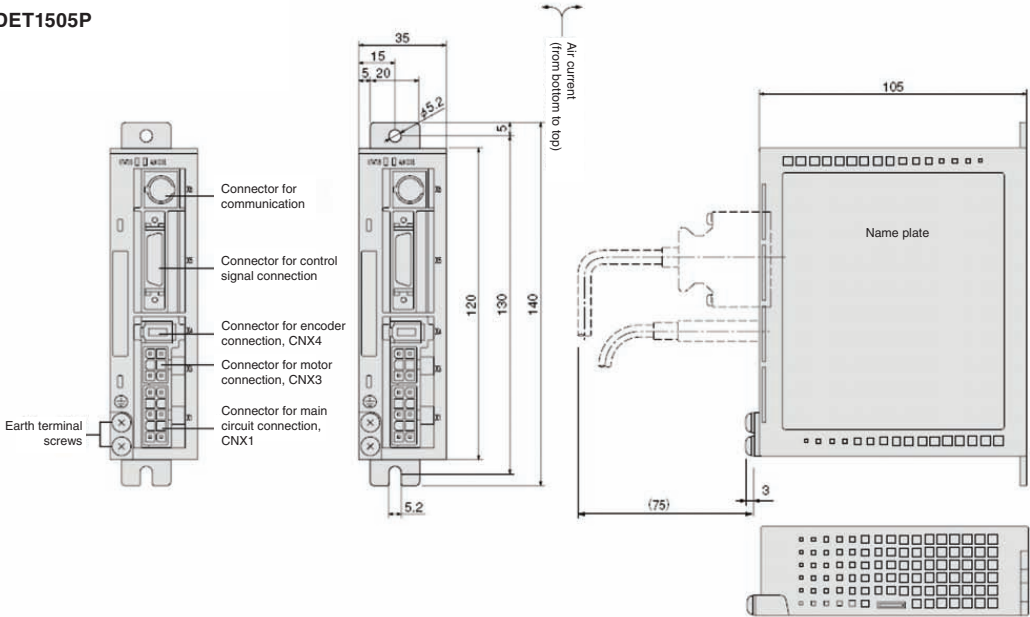

■ FRAME L

MLDET2210P, MLDET2510P

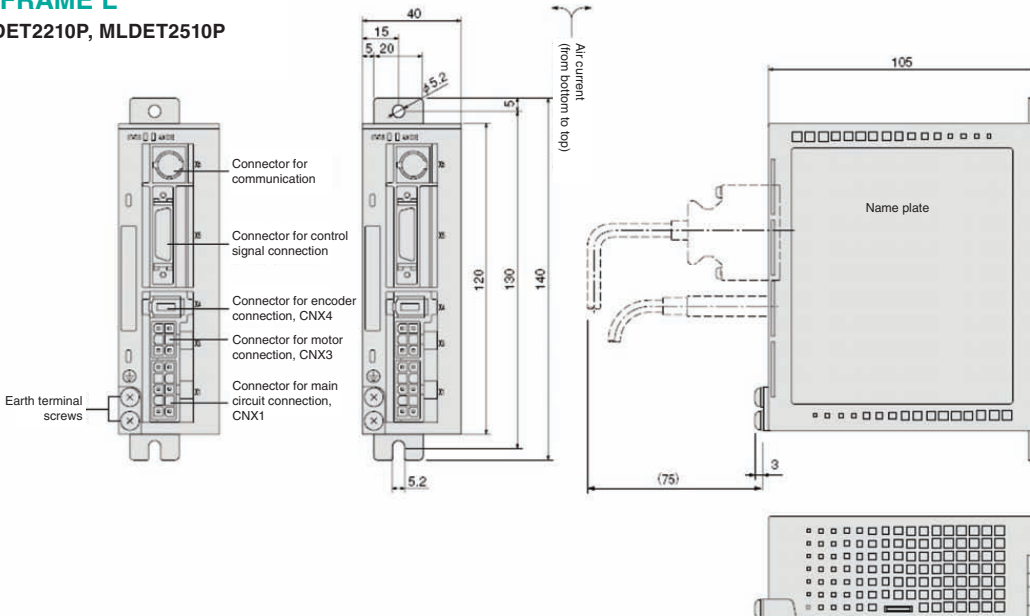

All measurements in mm



B Minas A4/A4N/A4P Series Servo Drives

Driver dimensions

FRAME A

Minas A4N

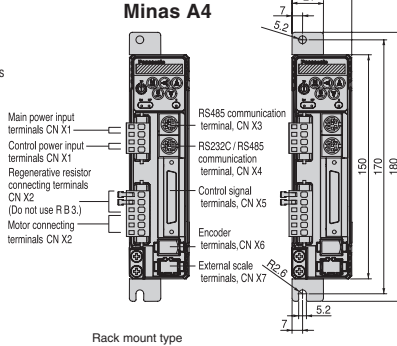
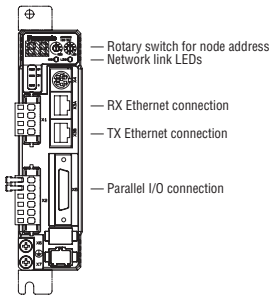

Rack mount type

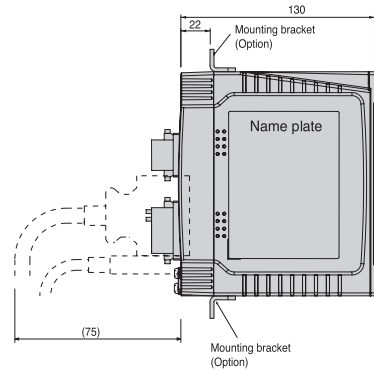

Base mount type (Standard: Back-end mounting)

FRAME B

Minas A4N

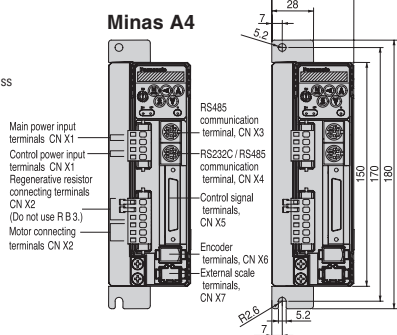
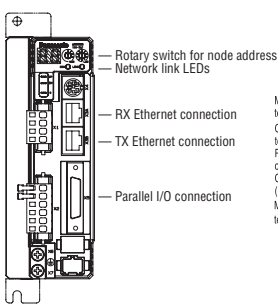

Rack mount type (Option: Front-end mounting)

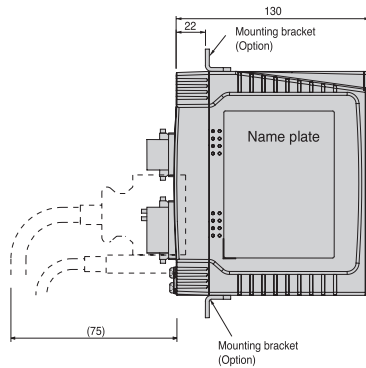

Base mount type (Standard: Back-end mounting)

FRAME C

Minas A4N

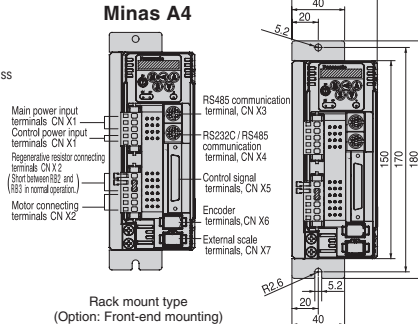
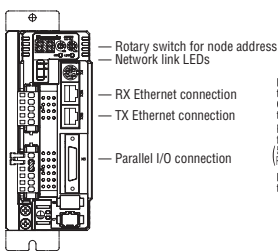

Rack mount type (Option: Front-end mounting)

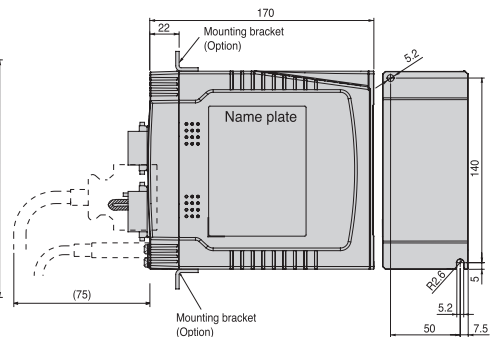

Base mount type (Standard: Back-end mounting)

All measurements in mm
Same dimensions for Minas A4P drivers

B Minas A4/A4N/A4P Series Servo Drives

Driver dimensions

FRAME D

Minas A4N

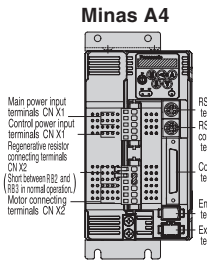
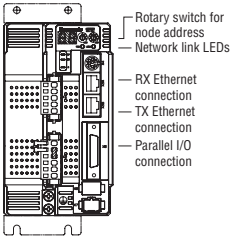

Rack mount type
(Option: Front-end mounting)

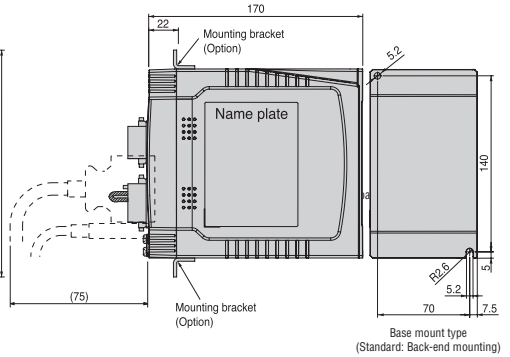
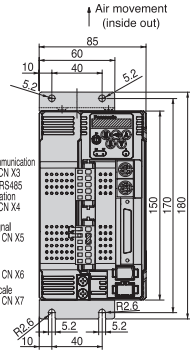

FRAME E

Minas A4N

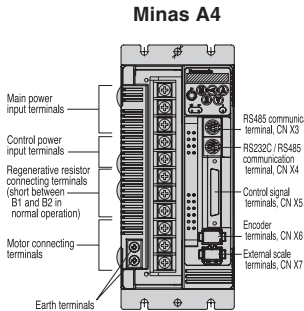
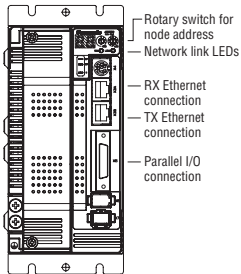

Minas A4

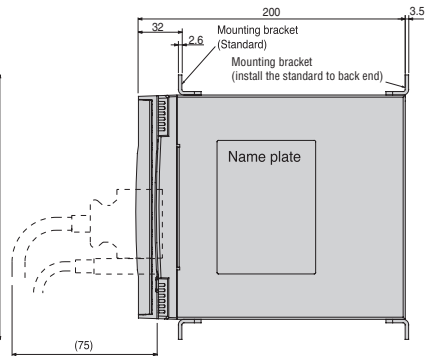
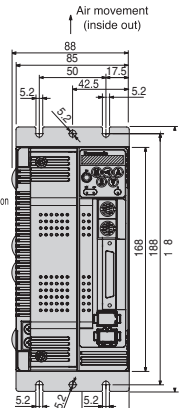

FRAME F

Minas A4N

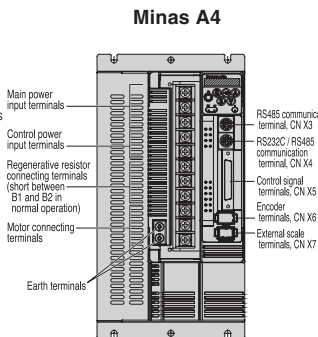
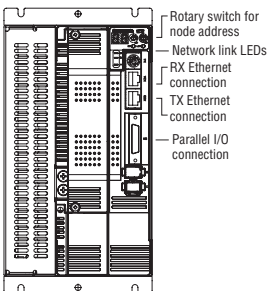

Minas A4

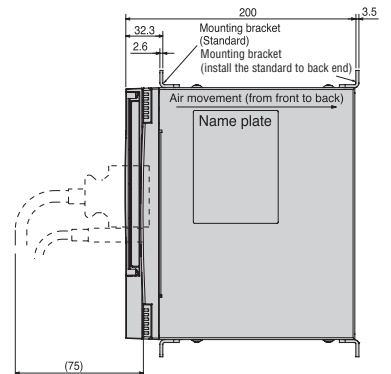
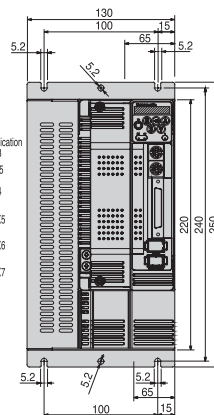

All measurements in mm



B Minas A4/A4N/A4P/E Series Servo Drives

Motor types

Motor product number	Rated power	Driver product number	Torque		Moment of inertia $\times 10^{-4} \text{kgm}^2$	Shaft	Oil seal	Holding brake	Encoder	With IP67 connectors									
			Rated	Momentary max. peak															
MSMD5AZP1A	50W	MADDT1205 or MADDT1205N or MADDT1205P	0.16Nm	0.48Nm	0.025	Round			Incremental	Option available*									
MSMD5AZP1C					0.025	Round	x	Incremental	Option available*										
MSMD5AZP1D					0.027	Round	x	Incremental	Option available*										
MSMD5AZP1S					0.025	Keyway		Incremental	Option available*										
MSMD5AZP1T					0.027	Keyway	x	Incremental	Option available*										
MSMD5AZS1S					0.025	Keyway		Absolute	Option available*										
MSMD012P1A	100W	MADDT1205 or MADDT1205N or MADDT1205P	0.32Nm	0.95Nm	0.051	Round			Incremental	Option available*									
MSMD012P1C					0.051	Round	x	Incremental	Option available*										
MSMD012P1D					0.054	Round	x	Incremental	Option available*										
MSMD012P1S					0.051	Keyway		Incremental	Option available*										
MSMD012P1T					0.054	Keyway	x	Incremental	Option available*										
MSMD012S1S					0.051	Keyway		Absolute	Option available*										
MSMD022P1A	200W	MADDT1207 or MADDT1207N or MADDT1207P	0.64Nm	1.91Nm	0.14	Round			Incremental	Option available*									
MSMD022P1C					0.14	Round	x	Incremental	Option available*										
MSMD022P1D					0.16	Round	x	Incremental	Option available*										
MSMD022P1S					0.14	Keyway		Incremental	Option available*										
MSMD022P1T					0.16	Keyway	x	Incremental	Option available*										
MSMD022S1C					0.14	Keyway			Round	x		Absolute	Option available*						
MSMD022S1S														Keyway				Absolute	Option available*
MSMD022S1T																			
MSMD042P1A														400W	MBDDT2210 or MBDDT2210N or MBDDT2210P	1.3Nm	3.8Nm	0.26	Round
MSMD042P1C					0.26	Round	x	Incremental	Option available*										
MSMD042P1D	0.28	Round	x	Incremental	Option available*														
MSMD042P1S	0.26	Keyway		Incremental	Option available*														
MSMD042P1T	0.28	Keyway	x	Incremental	Option available*														
MSMD042S1C	0.26	Keyway			Round	x		Absolute	Option available*										
MSMD042S1S										Keyway								Absolute	Option available*
MSMD082P1A																			
MSMD082P1C										0.87	Round	x	Incremental	Option available*					
MSMD082P1D	0.97	Round	x	Incremental	Option available*														
MSMD082P1S	0.87	Keyway		Incremental	Option available*														
MSMD082P1T	0.97	Keyway	x	Incremental	Option available*														
MSMD082S1S	0.87	Keyway		Absolute	Option available*														
MSMA102P1G	1kW	MDDDT5540, MDDDT5540N or MDDDT5540P	3.18Nm	9.5Nm	1.69	Keyway	x		Incremental	x									
MSMA102P1H					1.88	Keyway	x	x	Incremental	x									
MSMA152P1G	1.5kW		4.77Nm	14.3Nm	2.59	Keyway	x		Incremental	x									
MSMA152P1H					2.84	Keyway	x	x	Incremental	x									
MSMA202P1G	2kW	MEDDT7364, MEDDT7364N, MEDDT7364P	6.36Nm	19.1Nm	3.46	Keyway	x		Incremental	x									
MSMA202P1H					3.81	Keyway	x	x	Incremental	x									
MSMA302P1G	3kW	MFDDTA390, MFDDTA390N, MFDDTA390P	9.54Nm	28.6Nm	6.77	Keyway	x		Incremental	x									
MSMA302P1H					7.45	Keyway	x	x	Incremental	x									
MSMA402P1G	4kW	MFDDTB3A2 or MFDDTB3A2N, MFDDTB3A2P	12.6Nm	37.9Nm	12.7	Keyway	x		Incremental	x									
MSMA402P1H					14.1	Keyway	x	x	Incremental	x									
MSMA502P1G	5kW		15.8Nm	47.6Nm	17.8	Keyway	x		Incremental	x									
MSMA502P1H					19.7	Keyway	x	x	Incremental	x									
Minas E																			
MUMA012P1S	100W	MKDET1505P	0.32Nm	0.95Nm	0.032	Keyway			Incremental										
MUMA012P1T					0.036	Keyway		x	Incremental										
MUMA022P1S	200W	MLDET2210P	0.64Nm	1.91Nm	0.10	Keyway			Incremental										
MUMA022P1T					0.13	Keyway		x	Incremental										
MUMA042P1S	400W	MLDET2510P	1.3Nm	3.8Nm	0.17	Keyway			Incremental										
MUMA042P1T					0.20	Keyway		x	Incremental										

* To order a motor with IP67 connectors, simply add an X to the PN, e.g. MSMD042P1SX, or MSMD042P1TX (brake motor).



B Minus E Series Servo Drives

Motor specifications

50W–400W

		AC200V			
Motor model	MUMA	5AZP1□	012P1□	022P1□	042P1□
Applicable driver	Model no.	MKDET1505P		MKDET1310P	MLDET2310P
	Frame symbol	Frame K			Frame L
Power supply capacity (kVA)		0.3		0.5	0.9
Rated output (W)		50		100	200
Rated torque (N • m)		0.16		0.32	0.64
Momentary max. peak torque (N • m)		0.48		0.95	1.91
Rated current (Arms*)		1.0		1.6	2.5
Max. current (Ao-p)		4.3		7.5	11.7
Regenerative brake frequency (times/min) ¹	Without option	No limit ²			
	DV0P2891×1	No limit ²			
Rated rotational speed (r/min)		3000			
Max. rotational speed (r/min)		5000			
Moment of inertia of rotor (x10 ⁻⁴ kg • m ²)	Without brake	0.021	0.032	0.10	0.17
	With brake	0.026	0.036	0.13	0.20
Recommended moment of inertia ratio of the load and the rotor ³		Smaller than 30 times			
Rotary encoder specifications		2500P/r Incremental			
Resolution per single turn		10,000			
Protective enclosure rating		IP65 (except shaft through hole and cable end connector)			
Environment	Ambient temperature	0°C to 40°C, storage: -20°C to + 80°C			
	Ambient humidity	85%RH or lower (free of condensation)			
	Installation location	Indoors (no direct sunlight), free from corrosive gas, inflammable gas, oil mist and dust			
	Altitude	1000m or lower			
Vibration resistance		49m/s ² or less			
Mass (kg), () represents holding brake type		0.4 (0.6)	0.5 (0.7)	0.96 (1.36)	1.5 (1.9)
Brake specifications (This brake will be released when it is energized. Do not use this for braking the motor while it is running.)					
Static friction torque (N • m)		0.29		1.27	
Engaging time (ms)		25		50	
Releasing time (ms) ⁴		20 (30)		15 (100)	
Operating current (DC) (A)		0.26		0.36	
Releasing voltage		DC 1V or more			
Operating voltage		DC 24V ±10%			
Permissible load					
During assembly	Radial load P-direction (N)	147		392	
	Thrust load A-direction (N)	88		147	
	Thrust load B-direction (N)	117		196	
During operation	Radial load P-direction (N)	68		245	
	Thrust load A-direction (N)	58		98	
	Thrust load B-direction (N)	58		98	

For notes 1–4, see page 26

*rms = root mean square

Note: Driver for 50W and 100W has a common power supply of single phase and 3-phase, 200V



B Minas A4/A4N/A4P Series Servo Drives

Motor specifications

50W-750W

		AC200V					
Motor model		MSMD5AZP1□	MSMD012P1□	MSMD022P1□	MSMD042P1□	MSMD082P1□	
Applicable driver	Model no.	MADDT1205 / MADDT1205N		MADDT1207 (N)	MBDDT2210 (N)	MCDDT3520 (N)	
	Frame symbol	Frame A			Frame B	Frame C	
Power supply capacity (kVA)		0.3		0.5	0.9	1.3	
Rated output (W)		50	100	200	400	750	
Rated torque (N • m)		0.16	0.32	0.64	1.3	2.4	
Momentary max. peak torque (N • m)		0.48	0.95	1.91	3.8	7.1	
Rated current (Arms*)		1.1		1.6	2.6	4	
Max. current (Ao-p)		4.7		6.9	11.0	17.0	
Regenerative brake frequency (times/min) ¹	Without option	No limit ²					
	With external brake resistor	No limit ²					
Rated rotational speed (r/min)		3000					
Max. rotational speed (r/min)		5000				4500	
Moment of inertia of rotor (x10 ⁻⁴ kg • m ²)	Without brake	0.025	0.051	0.14	0.26	0.87	
	With brake	0.027	0.054	0.16	0.28	0.97	
Recommended moment of inertia ratio of the load and the rotor ³		Smaller than 30 times					Smaller than 20 times
Rotary encoder specifications		2500P/r Incremental					
Resolution per single turn		10,000					
Protective enclosure rating		IP65 (except shaft through hole and cable end connector)					
Environment	Ambient temperature	0°C to 40°C, storage : -20°C to +80°C					
	Ambient humidity	85%RH or lower (free of condensation)					
	Installation location	Indoors (no direct sunlight), free from corrosive gas, inflammable gas, oil mist and dust					
	Altitude	1000m or lower					
Vibration resistance		49m/s ² or less					
Mass (kg), () represents holding brake type		0.32 (0.53)	0.47 (0.68)	0.82 (1.3)	1.2 (1.7)	2.3 (3.1)	
Brake specifications (This brake will be released when it is energized. Do not use this for braking the motor while it is running.)							
Static friction torque (N • m)		0.29		1.27		2.45	
Engaging time (ms)		35		50		70	
Releasing time (ms) ⁴		20 (-)		15 (-)		20 (-)	
Operating current (DC) (A)		0.30		0.36		0.42	
Releasing voltage		DC 1V or more					
Operating voltage		DC 24V ±5%					
Permissible load							
During assembly	Radial load P-direction (N)	147		392		686	
	Thrust load A-direction (N)	88		147		294	
	Thrust load B-direction (N)	117		196		392	
During operation	Radial load P-direction (N)	68		245		392	
	Thrust load A-direction (N)	58		98		147	
	Thrust load B-direction (N)	58		98		147	

For notes 1-4, see page 26
*rms = root mean square

B Minas A4/A4N/A4P Series Servo Drives

Torque characteristics

MSMD5AZ□1□

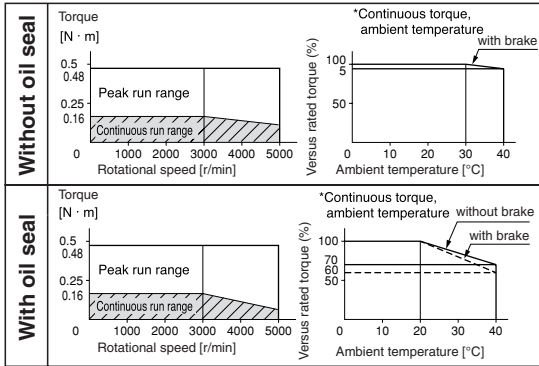

MSMD012□1□

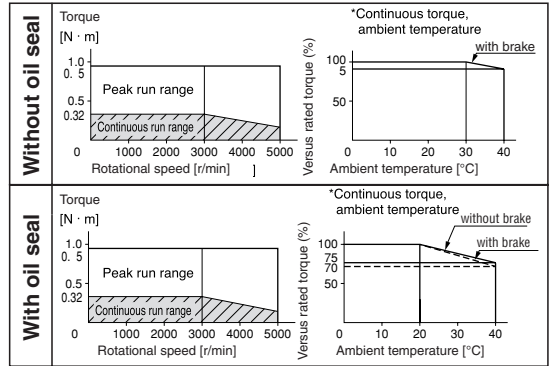

MSMD022□1□

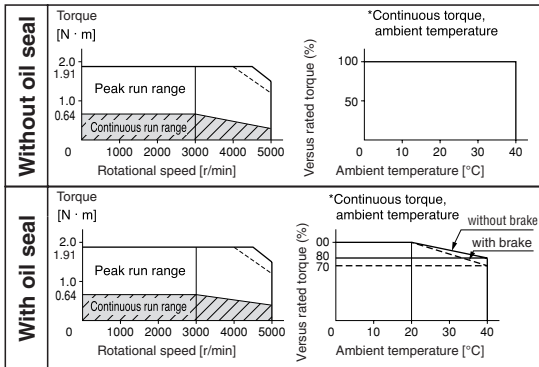

MSMD042□1□

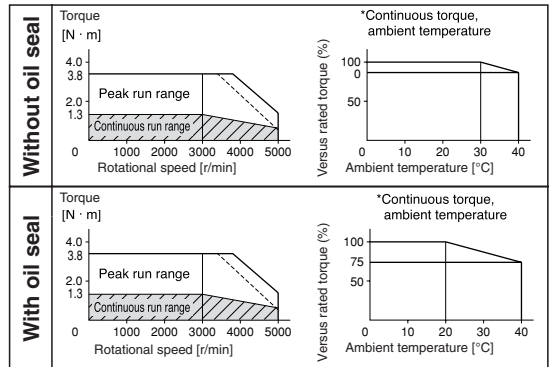

MSMD082□1□

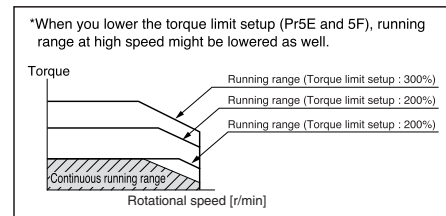
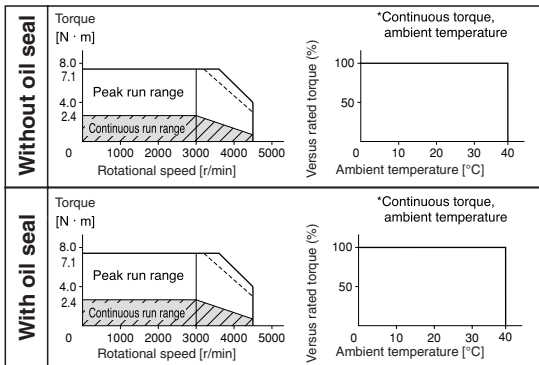



B Minas A4/A4N/A4P Series Servo Drives

Motor dimensions

MSMD 50W–750W (LOW INERTIA)

HIGH QUALITY CONNECTORS

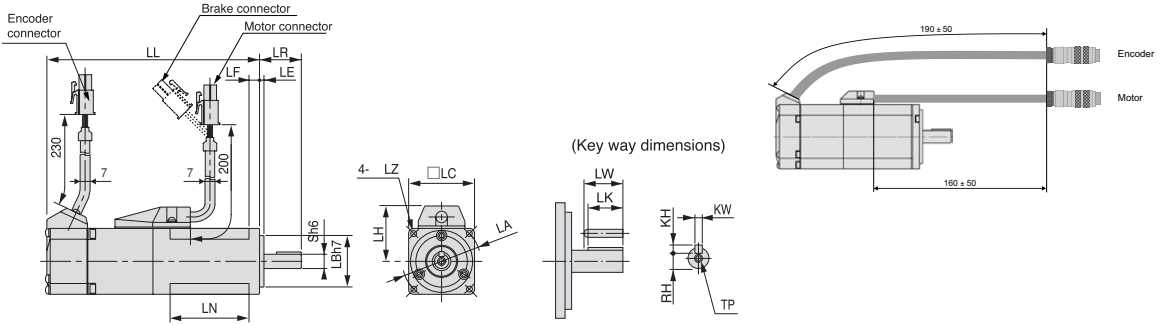

Dimensions are subject to change without notice. Contact us or a dealer for the latest information.

		Minas A4 series (low inertia)				
Motor output		50W	100W	200W	400W	750W
Motor model		MSMD5AZP1□	MSMD012P1□	MSMD022P1□	MSMD042P1□	MSMD082P1□
Rotary encoder specifications		2500P/r incremental				
LL	Without brake	72	92	79	98.5	112
	With brake	102	122	115.5	135	149
LR		25		30		35
S		8		11	14	19
LA		45		70		90
LB		30		50		70
LC		38		60		80
LD				—		
LE				3		
LF		6		6.5		8
LG				—		
LH		32		43		53
LN		26.5	46.5		—	
LZ		3.4		4.5		6
Keyway	LW	14		20		25
	LK	12.5		18	22.5	22
	KW	3h9		4h9	5h9	6h9
	KH	3		4	5	6
	RH	6.2		8.5	11	15.5
	TP	M3 x 6 (depth)		M4 x 8 (depth)		M5 x 10 (depth)
Mass (kg)	Without brake	0.32	0.47	0.82	1.2	2.3
	With brake	0.53	0.68	1.3	1.7	3.1



B Minas A4/A4N/A4P Series Servo Drives

Motor specifications

1kW–5kW

		AC200V					
Motor model		MSMA102P1□	MSMA152P1□	MSMA202P1□	MSMA302P1□	MSMA402P1□	MSMA502P1□
Applicable driver	Model no.	MDDDT5540/N		MEDDT7364/N	MFDDTA390/N	MFDDTB3A2/N	
	Frame symbol	Frame D		Frame E	Frame F		
Power supply capacity (kVA)		1.8	2.3	3.3	4.5	6.0	7.5
Rated output (W)		1000	1500	2000	3000	4000	5000
Rated torque (N • m)		3.18	4.77	6.36	9.54	12.6	15.8
Momentary max. peak torque (N • m)		9.5	14.3	19.1	28.6	37.9	47.6
Rated current (Arms*)		7.2	9.4	13.0	18.6	24.7	28.5
Max. current (Ao-p)		30	40	56	80	105	120
Regenerative brake frequency (times/min) ¹	Without option	No limit ²					
	With external brake resistor	—		No limit ²		No limit ²	
Rated rotational speed (r/min)		3000			4500		
Max. rotational speed (r/min)		5000			4500		
Moment of inertia of rotor (x10 ⁻⁴ kg • m ²)	Without brake	1.69	2.59	3.46	6.77	12.7	17.8
	With brake	1.88	2.84	3.81	7.45	14.1	19.7
Recommended moment of inertia ratio of the load and the rotor ³		Smaller than 15 times					
Rotary encoder specifications		2500P/r Incremental					
Resolution per single turn		10,000					
Protective enclosure rating		IP65 (except shaft through hole and cable end connector)					
Environment	Ambient temperature	0°C to 40°C (free from freezing), Storage : -20°C to + 80°C					
	Ambient humidity	85%RH or lower (free from condensing)					
	Installation location	Indoors (no direct sunlight), free from corrosive gas, inflammable gas, oil mist and dust					
	Altitude	1000m or lower					
Vibration resistance		49m/s ² or less					
Mass (kg), () represents holding brake type		4.5 (5.1)	5.1 (6.5)	6.5 (7.9)	9.3 (11.0)	12.9 (14.8)	17.3 (19.2)
Brake specifications (This brake will be released when it is energized. Do not use this for braking the motor in motion.)							
Static friction torque (N • m)		4.9	7.8		11.8	16.1	
Engaging time (ms)		50			80	110	
Releasing time (ms) ⁴		15 (100)			50 (130)		
Operating current (DC) (A)		0.74	0.81		0.81	0.90	
Releasing voltage		DC 2V or more					
Operating voltage		DC 24V ±10%					
Permissible load							
During assembly	Radial load P-direction (N)	686			980		
	Thrust load A-direction (N)	392			588		
	Thrust load B-direction (N)	490			686		
During operation	Radial load P-direction (N)	392		490		784	
	Thrust load A-direction (N)	147		196		343	
	Thrust load B-direction (N)	147		196		343	

For notes 1–4 see Page 26
*rms= root mean square



B Minas A4/A4N/A4P Series Servo Drives

Motor characteristics 1kW to 5kW

MSMA102□1□

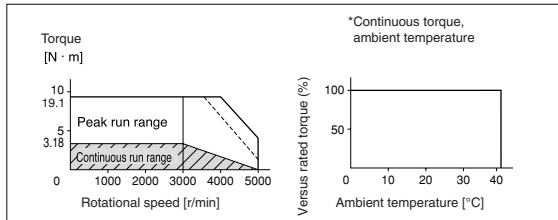

MSMA152□1□

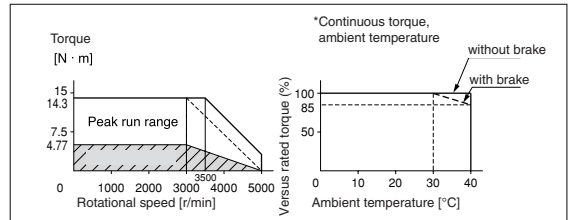

MSMA202□1□

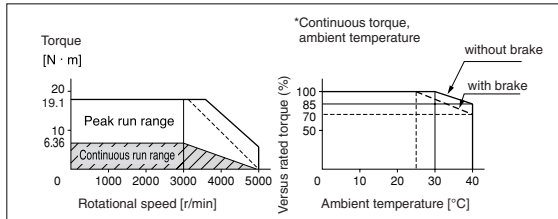

MSMA302□1□

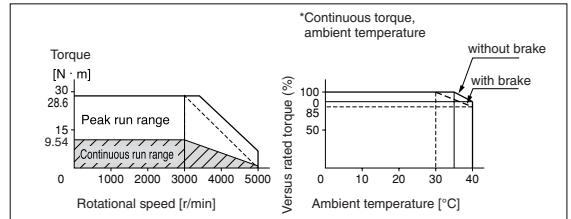

MSMA402□1□

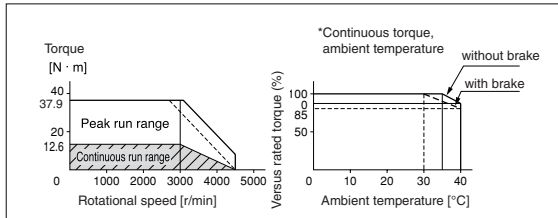

MSMA502□1□

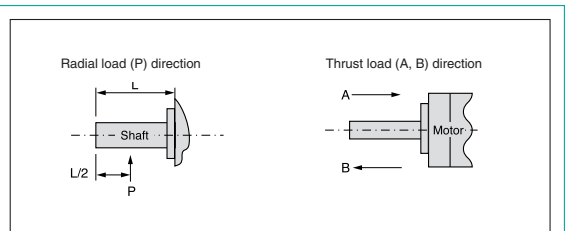
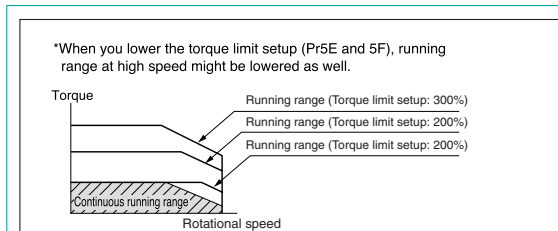
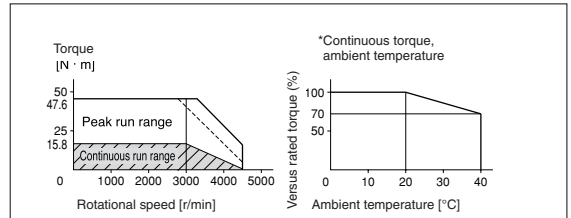

Notes:

- Regenerative brake frequency represents the frequency of the motor's stops from the rated speed with deceleration without load.
 - If the load is connected, frequency will be defined as $1/(m+1)$, where m =load moment of inertia/load moment of inertia.
 - When the motor speed exceeds the rated speed, regenerative brake frequency is in inverse proportion to the square of (running speed/rated speed).
 - Power supply voltage is AC230V (at 200V of the main voltage). If the supply voltage fluctuates, frequency is in inverse proportion to the square of (running supply voltage/230) relative to the value in the table.
 - When regeneration occurs continuously, e.g. frequent changes in running speed or vertical feeding, consult either us or a dealer.

- If the effective torque is within the rated torque, there is no limit in generative brake.
- Consult us or a dealer if the load moment of inertia exceeds the specified value.
- Specified releasing time is obtained with the use of surge absorber for brake (Z15D151 by Ishizuka Electronic or equivalent).

() Represents the actually measured value using a diode (200V, 1A or equivalent).

B Minas A4/A4N/A4P Series Servo Drives

Motor dimensions

MSMA 1kW–5kW (LOW INERTIA)

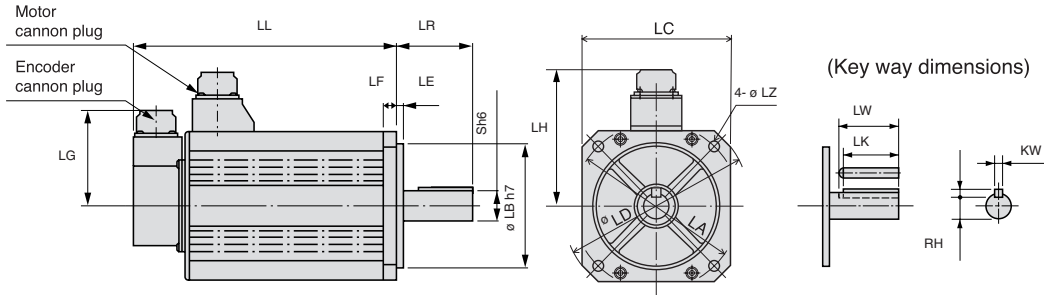

Dimensions are subject to change without notice. Contact us or a dealer for the latest information.

		Minas A4 series (low inertia)					
Motor output		1.0kW	1.5kW	2.0kW	3.0kW	4.0kW	5.0kW
Motor model		MSMA102P1□	MSMA152P1□	MSMA202P1□	MSMA302P1□	MSMA402P1□	MSMA502P1□
Rotary encoder specifications		2500P/r incremental					
LL	Without brake	175	180	205	217	240	280
	With brake	200	205	230	242	265	305
LR		55			55	65	
S		19			22	24	
LA		100	115		130/145 (slot)	145	
LB		80	95		110		
LC		90	100		120	130	
LD		120	135		162	165	
LE					3	6	
LF		7	10		12		
LG					84		
LH		98	103		111	118	
LZ		6.6			9		
Keyway	LW				45		55
	LK	42			41		51
	KW	6h9			8h9		
	KH	6			7		
RH		15.5			18		20
Mass (kg)	Without brake	4.5	5.1	6.5	9.3	12.9	17.3
	With brake	5.1	6.5	7.9	11.0	14.8	19.2
Connector/Plug specifications		Refer to Minas A4 Manual					



B Minas E Series Servo Drives

Motor dimensions Minas E 100W–400W

MUMA (LOW INERTIA)

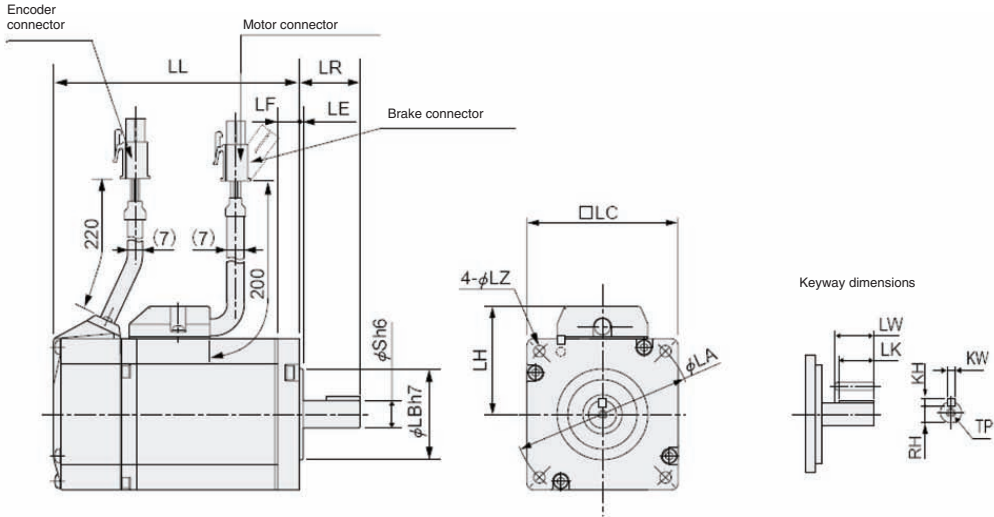

Dimensions are subject to change without notice; please contact us or a dealer for current information.

		MUTMA series (ultra low inertia)			
Motor output		50W	100W	200W	400W
Motor model	MUMA	5A□P1□	01□P1□	02□P1□	04□P1□
Rotary encoder specifications		2500P/r incremental			
LL	Without brake	75,5	92,5	96	123,5
	With brake	107	124	129	156,5
LR			24		30
S			8	11	14
LA			48		70
LB			22		50
LC			42		60
LE			2		3
LF				7	
LH			34		43
LZ			3,4		4,5
Keyway	LW		14	20	25
	LK		12,5	18	22,5
	KW		3h9	4h9	5h9
	KH		3	4	5
	RH		6,2	8,5	11
	TP		M3 X 6 (depth)		M4 X 8 (depth)
Mass (kg)	Without brake	0.40	0.50	0.96	1.5
	With brake	0.60	0.70	1.36	1.90
Connector/Plug specifications		Refer to options, page 35			

* Cautions: Reduce the moment of inertia if high speed response operation is required.
Read the Instruction Manual carefully and understand all precautions and remarks before using the products.

Software

Setup support software

■ SETUP SUPPORT SOFTWARE PANATERM® FOR MINAS SERIES AC SERVO MOTOR & DRIVER

PANATERM® assists users in setting parameters, monitoring control conditions, setup support and analysing mechanical operation data on the PC screen when installed in a commercially available personal computer and connected to the Minas series through the RS232C serial interface.



■ BASIC FUNCTION

Parameter setup

- After a parameter has been defined on the screen, it will immediately be sent to the driver.
- Once you register the parameters you frequently use, they can easily be set up on the screen.
- Enter position data for Minas ACP drivers.

■ MONITORING CONTROL CONDITIONS

Monitor

- Control conditions: control mode, velocity, torque, error and warning.
- Driver input signal.
- Load conditions: total count of command/feedback pulses, load ratio, regenerative resistor load ratio.

Alarm

- Displays the numbers and contents of the current alarm and a history of the last 14 error events.
- Clears the numbers and contents of the current alarm and a history of the last 14 error events.

■ SETUP

Auto tuning

- Gain adjustment and inertia ratio measurement.

Graphic waveform display

- The graphic display shows command velocity, actual velocity, torque, and error waveforms.

Absolute encoder setup

- Clears absolute encoder at the origin.
- Displays single revolution/multirevolution data.
- Displays absolute encoder status.

■ ANALYSIS OF MECHANICAL OPERATION DATA

Frequency analysis

- Measures frequency characteristics of the machine; displays Bode diagram.

Product number: DVOP4460

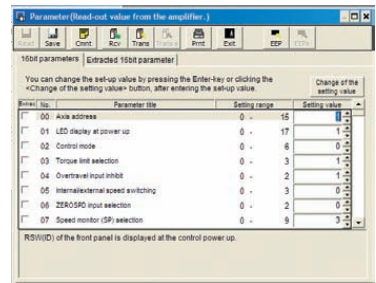

Parameter

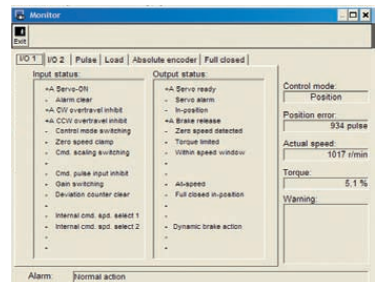

Monitor

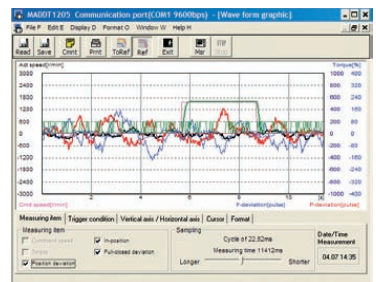

Graphic waveform display



Software

Motion Control Library for FPWIN Pro

Panasonic's Motion Control Library is designed to save programming time with a sophisticated yet user-friendly software solution. Our library includes function blocks programmed according to PLCopen's specifications. Developed to simplify programming of FP2 and FPΣ (Sigma) positioning units.



PLCopen, an independent international organization, aims to harmonize access across platforms during development, installation and maintenance based on the IEC61131-3 environment.

See also: www.plcopen.org/MC_Certification/Panasonic/shortform_statement_Panasonic.htm

Administrative		Motion	
Single Axis	Multiple Axis	Single Axis	Multiple Axis
MC_Power	MC_CamTableSelect	MC_MoveAbsolute	MC_CamIn
MC_ReadStatus		MC_MoveRelative	MC_CamOut
MC_ReadAxisError		MC_MoveAdditive *	MC_GearIn
MC_ReadParameter		MC_MoveSuperimposed	MC_GearOut
MC_ReadBoolParameter		MC_MoveVelocity	
MC_WriteParameter		MC_Home	
MC_WriteBoolParameter		MC_Stop	
MC_ReadActualPosition		MC_PositionProfile	
MC_Reset		MC_VelocityProfile	
		MC_AccelerationProfile	

* If executed, the current motion is briefly interrupted due to hardware reasons.

PROGRAM, LADDER DIAGRAM BODY

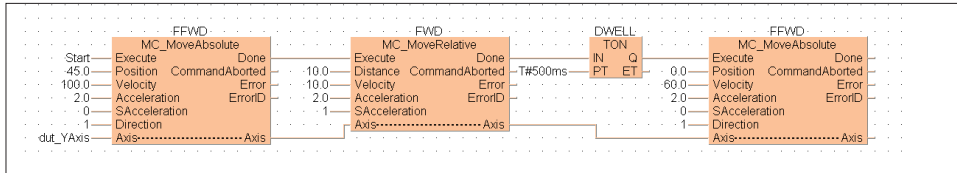

EXAMPLE FOR CONSECUTIVE MOVEMENT IN A DRILLING APPLICATION

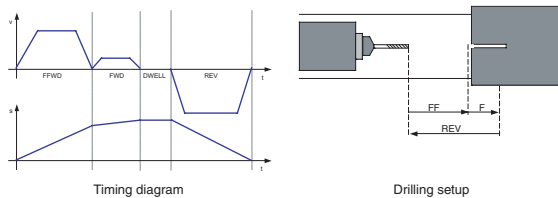

ADVANTAGES OF PLC PROGRAMS USING THE MOTION CONTROL LIBRARY COMPLIANT WITH THE PLCOPEN STANDARD:

- **Simple** – Easy programming and installation, even for complex applications
- **Efficient** – In the number of function blocks and in design and understanding
- **Consistent** – Compliant with the IEC 61131-3 PLC programming standard
- **Universal** – Hardware-independent
- **Flexible** – Add hardware or expand range of applications at any time
- **Complete** – Comprehensive product line solves typical positioning applications easily



Motion Control Library

Product number NCL-MC-LIB D

Note: FP2 positioning unit multifunction type version 5.4 or newer usable with FPΣ (Sigma) positioning unit

Software

Configurator PM software tool for RTEX

The Configurator PM provides powerful yet simple full support ranging from configuration settings and startup to operation monitoring. This reduces the time and man hours required for system setup.

Axis settings

Check the axis to be used. Select axis no. used.

Setting used axis

Interpolation group settings

Specify the axis to copy

Grouping of axes for interpolation operations is carried out simply by dragging and dropping the relevant axes.

Parameter settings

The details of the settings can be displayed in a table. Details on how to create settings for each category are explained in the box below.

Parameter settings	1 axis (A)	2 axis (A)	6 axis (B)	7 axis (B)	8 axis (B)
Unit setting	Pulse	Pulse	Pulse	Pulse	Pulse
Pulse number per rotation					
Movement amount per rotation					
CM/CMW direction setting	Not available	Not available	Not available	Not available	Not available
CM/CMW direction setting	Not available	Not available	Not available	Not available	Not available
Limit switch	Standard	Standard	Standard	Standard	Standard
Limit switch connection	Not available	Not available	Not available	Not available	Not available
Software limit (Positioning control)	Not available	Not available	Not available	Not available	Not available
Software limit (Drive return)	Not available	Not available	Not available	Not available	Not available
Software limit (JOG operation)	Not available	Not available	Not available	Not available	Not available
Upper limit of software limit	1077741623	1077741623	1077741623	1077741623	1077741623
Lower limit of software limit	1077741623	1077741623	1077741623	1077741623	1077741623
Auxiliary output mode	Not used	Not used	Not used	Not used	Not used
Auxiliary output ON time (ms)	10	10	10	10	10
Completion wait (ms)	10	10	10	10	10
Monitor error - Torque Judgment	Not available	Not available	Not available	Not available	Not available
Monitor error - Torque Judgment value (N)	800	800	800	800	800
Monitor error - Torque Judgment value (N)	800	800	800	800	800

Parameters can be copied between axes. In instances where many settings are shared among the axes, this can reduce the number of repeat inputs.

Data table creation

Simple input as in Excel.

Each axis (or each interpolation axis group) has a separate sheet, and data tables for each axis are displayed in an easy-to-understand manner.

Table No.	Program	Interpolation operation	Control method	X axis(1) movement	Y axis(2) movement	Z axis(3) movement
1	E End	Linear Composite	1 Increment	0	0	0
2	E End	Linear Composite	1 Increment	0	0	0
3	E End	Linear Composite	1 Increment	0	0	0
4	E End	Linear Composite	1 Increment	0	0	0
5	E End	Linear Composite	1 Increment	0	0	0
6	E End	Linear Composite	1 Increment	0	0	0
7	E End	Linear Composite	1 Increment	0	0	0
8	E End	Linear Composite	1 Increment	0	0	0
9	P Pass	Linear Composite	1 Increment	0	0	0
10	P Pass	Linear Composite	A Resultate	1000000	2000000	0
11	P Pass	Linear Composite	A Resultate	3000000	1000000	0
12	P Pass	Linear Composite	A Resultate	1000000	3000000	0
13	E End	Linear Composite	1 Increment	0	0	0
14	E End	Linear Composite	1 Increment	0	0	0
15	E End	Linear Composite	1 Increment	0	0	0
16	E End	Linear Composite	1 Increment	0	0	0
17	E End	Linear Composite	1 Increment	0	0	0
18	E End	Linear Composite	1 Increment	0	0	0
19	E End	Linear Composite	1 Increment	0	0	0
20	P Pass	Linear Composite	A Resultate	1000000	3000000	3000000
21	P Pass	Linear Composite	A Resultate	3000000	1000000	3000000
22	P Pass	Linear Composite	A Resultate	1000000	3000000	3000000
23	P Pass	Linear Composite	A Resultate	1000000	3000000	3000000
24	P Pass	Linear Composite	A Resultate	1000000	3000000	3000000

Data tables can be exported as text files in CSV format. This is effective when making printouts for document management.

You can copy parts of a CSV file to a data table using Cut & Paste.

TOOL OPERATIONS

- Each axis can be operated by tool operation independently from the operation modes (PROG and RUN) of the FP control unit (or the FP2CPU unit).
- JOG operation and teaching can be carried out easily to index positioning points. Test operation is possible without having to create a rudder program.

DATA MONITOR

- Data table no. during operation
- Auxiliary output
- Current position, speed and vector
- Error code, warning code (Errors and warnings can also be cleared)

STATUS MONITOR

- Connection status of each axis
- Model code of each motor amp and motor connected
- Servo lock status
- Origin proximity input, limit input



Software

Encoder cables

Encoder cables for Minas A4 and E servo drives, standard connectors, usable for drag chain

Product number	Power range Minas A4	Power range Minas E	Length L
MFECA0010EAM	50–750W	50–400W	1m
MFECA0020EAM	50–750W	50–400W	2m
MFECA0030EAM	50–750W	50–400W	3m
MFECA0050EAM	50–750W	50–400W	5m
MFECA0100EAM	50–750W	50–400W	10m

Encoder cable for Minas A4 servo drives, high quality connectors, IP67, usable for drag chain

Product number	Power range Minas A4	Length L
MFECA0020EAB	50–750W	2m
MFECA0030EAB	50–750W	3m
MFECA0040EAB	50–750W	4m
MFECA0050EAB	50–750W	5m
MFECA0070EAB	50–750W	7m
MFECA0100EAB	50–750W	10m
MFECA0150EAB	50–750W	15m
MFECA0200EAB	50–750W	20m

Encoder cable for Minas A4 with 17-bit absolute encoder, standard connectors, without battery holder

Product number	Power range Minas A4	Length L
MFECA0030EAD	50–750W	3m
MFECA0050EAD	50–750W	5m
MFECA0100EAD	50–750W	10m

Encoder cable for Minas A4 with 17-bit absolute encoder, standard connectors, with battery holder

Product number	Power range Minas A4	Length L
MFECA0030EAE	50–750W	3m
MFECA0050EAE	50–750W	5m
MFECA0100EAE	50–750W	10m

Encoder cable for Minas A4 with incremental encoder, IP67 metal connectors, usable for drag chain

Product number	Power range Minas A4	Length L
MFECA0030ESD	1–5kW	3m
MFECA0050ESD	1–5kW	5m
MFECA0100ESD	1–5kW	10m

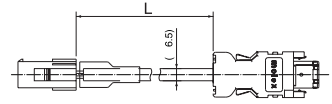

MFECA0□□0EAM



MFECA0□□0EAB

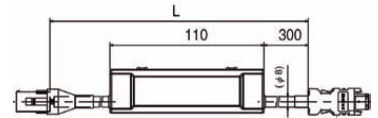

MFECA0□□0EAD

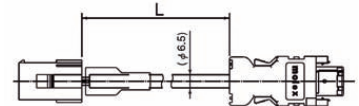

MFECA0□□0EAE

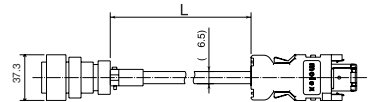

MFECA0□□0ESD

Accessories

Motor and brake cables

Motor cable for Minas A4 servo drives, usable for drag chain

Product number	Power range	Length L
MFMCA0010EED	50 – 750W	1m
MFMCA0020EED	50 – 750W	2m
MFMCA0030EED	50 – 750W	3m
MFMCA0050EED	50 – 750W	5m
MFMCA0100EED	50 – 750W	10m

Motor cable for Minas E servo drives, usable for drag chain

Product number	Power range	Length L
MFMCA0050AEB	50 – 400W	5m
MFMCA0100AEB	50 – 400W	10m
MFMCA0200AEB	50 – 400W	20m

Motor cable for Minas A4, high quality connectors, IP67, usable for drag chain

Product number	Power range	Length L
MFMCA0020EBD	50 – 750W	2m
MFMCA0030EBD	50 – 750W	3m
MFMCA0040EBD	50 – 750W	4m
MFMCA0050EBD	50 – 750W	5m
MFMCA0100EBD	50 – 750W	10m
MFMCA0150EBD	50 – 750W	15m
MFMCA0200EBD	50 – 750W	20m

Motor cable for Minas A4 motors with brake, high quality connectors, IP67, usable for drag chain

Product number	Power range	Length L
MFMCA0020EBDB	50 – 750W	2m
MFMCA0030EBDB	50 – 750W	3m
MFMCA0050EBDB	50 – 750W	5m
MFMCA0070EBDB	50 – 750W	7m
MFMCA0100EBDB	50 – 750W	10m

Motor cable for Minas A4, without brake, usable for drag chain

Product number	Power range	Length L
MFMCD0032ECD	1 – 1.5kW	3m
MFMCD0052ECD	1 – 1.5kW	5m
MFMCD0102ECD	1 – 1.5kW	10m

Motor cable for Minas A4, without brake, usable for drag chain

Product number	Power range	Length L
MFMCD0032ECT	2kW	3m
MFMCD0052ECT	2kW	5m
MFMCD0102ECT	2kW	10m
MFMCD0152ECT	2kW	15m

Motor cable for Minas A4, without brake, usable for drag chain

Product number	Power range	Length L
MFMCA0033ECT	3–5kW	3m
MFMCA0053ECT	3–5kW	5m
MFMCA0103ECT	3–5kW	10m

Motor cable for Minas A4, with brake, usable for drag chain

Product number	Power range	Length L
MFMCA0032FCD	1–1.5kW	3m
MFMCA0052FCD	1–1.5kW	5m
MFMCA0102FCD	1–1.5kW	10m

Motor cable for Minas A4, with brake, usable for drag chain

Product number	Power range	Length L
MFMCA0032FCT	2kW	3m
MFMCA0052FCT	2kW	5m
MFMCA0102FCT	2kW	10m

Motor cable for Minas A4, with brake, usable for drag chain

Product number	Power range	Length L
MFMCA0033FCT	3–5kW	3m
MFMCA0053FCT	3–5kW	5m
MFMCA0103FCT	3–5kW	10m

Brake junction cable for Minas A 4 and E motors with brake, usable for drag chain

Product number	Power range Minas A	Power range Minas E	Length L
MFMCB0030GET	50 – 750W	50 – 400W	3m
MFMCB0050GET	50 – 750W	50 – 400W	5m
MFMCB0100GET	50 – 750W	50 – 400W	10m

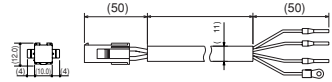

MFMCA0□□0EED

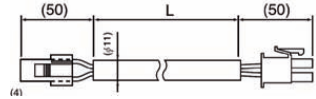

MFMCA0□□0AEB

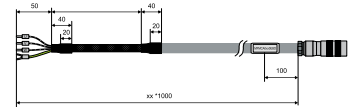

MFMCA0□□0EBD

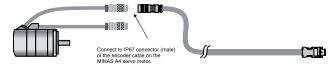

MFMCA0□□0EBDB

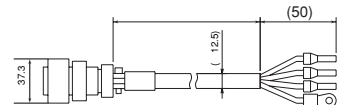

MFMCD0□□2ECD

MFMCD0□□2ECT

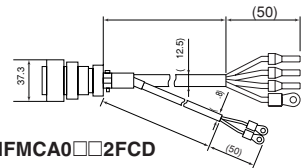

MFMCA0□□2FCD

MFMCA0□□2FCT

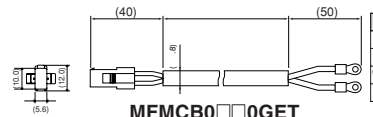

MFMCB0□□0GET

Accessories

Direct connection cables to FPΣ (Sigma) and FP2

For pulse control, not for Minas A4N / RTEX

Product number	Description	Number of axes	Power range	Length	Connectors
DVOP0980W-1	FPΣ (Sigma) NPN to CN I/F	1	0.05–5kW	1m	50 pin Molex to 2x10 pin MIL
DVOP0981W-1	FPΣ (Sigma) NPN to CN I/F	2	0.05–5kW	1m	2x50 pin Molex to 3x10 pin MIL
DVOP0982W-1	FPΣ (Sigma) PNP to CN I/F	1	0.05–5kW	1m	50 pin Molex to 2x10 pin MIL
DVOP0983W-1	FPΣ (Sigma) PNP to CN I/F	2	0.05–5kW	1m	2x50 pin Molex to 3x10 pin MIL
DVOP0984W-1	FPΣ (Sigma) NPN to CN I/F, with TLC-signal	2	0.05–5kW	1m	50 pin Molex to 2x10 pin MIL, with TLC-signal
DVOP0985W-1	FPΣ (Sigma) / FP2 Positioning units transistor type	2	0.05–5kW	1m	50 pin Molex to 1x40 pin MIL
DVOP0986W-1	FPΣ (Sigma) / FP2 Positioning units line driver type	2	0.05–5kW	1m	50 pin Molex to 1x40 pin MIL

For FPΣ (Sigma) CPU PNP or NPN

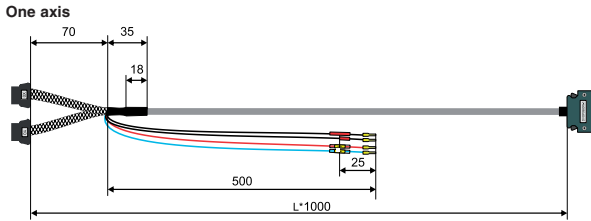

DVOP0980W-1
DVOP0982W-1

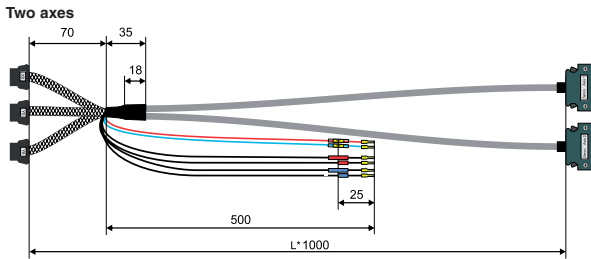

DVOP0981W-1
DVOP0983W-1
DVOP0984W-1



In/out connectors for the PLC FPΣ (Sigma). Unused inputs/outputs can be used for other purposes.

DIRECT CONNECTION TO FPΣ (SIGMA) AND FP2 POSITIONING UNITS

(Not for Minas A4N/RTEX transistor or line driver types)

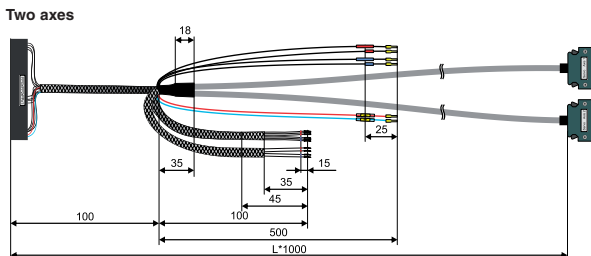

DVOP0985W-1
DVOP0986W-1



Accessories

Other cables, connectors, brake resistors, filters

COMMUNICATION CABLES

Product number	Description
DVOP1960	RS232C communication cable to PC9 pin Sub-D
DVOP1972	RS485 communication cable Mini-DIN 8Pin-MD connector, 1m

CONNECTOR UNITS

Product number	Description
DVOP3670	Connector kit for motor and encoder
DVOP4310	Connector kit for Minas A4 servo drives 1 to 2kW, without brake
DVOP4320	Connector kit for Minas A4 servo drives 3 to 5kW, without brake
DVOP4330	Connector kit for Minas A4 servo drives 1 to 2kW, with brake
DVOP4340	Connector kit for Minas A4 servo drives 3 to 5kW, with brake
DVOP4350	Connector for Minas A4 drivers for external equipment
DVOP4380	Connector kit for Minas A4 servo for encoder- and motor connection

FILTERS

Product number	Description
FN2060-6-06	EMC filter for control circle, Minas A4 servo drives 1 to 2kW
FN2090-10-06	Multi-stage EMI filter, 1-phase, for Minas A4/N servo driver MDDT5540, 1 to 1.5kW
FN2410-32-33	Multi-stage EMI filter, 1-phase, for Minas A4/N servo driver 2 to 5kW
FS21238-6-07	FS21238-6-07 EMC filter for Minas A4 servo drives 50 to 750W
DVOP4160	EMC filter for Minas E

INTERFACE CABLES

Product number	Description
DVOP0800	Interface cable for Minas E driver 26 pins
DVOP4360	Interface Connector cable for Minas A4 drivers, length 2m
DVOP4510	I/O Interface cable for Minas A4N and A4P servo drivers, length 2m

BRAKE RESISTORS

Product number	Power range	Additional information / description
BWD250100	30–750W	100 Ohm/100W
BWD600027	1–5kW	27 Ohm/240W

OTHER ACCESSORIES

Product number	Description
DVOP2990	Lithium battery for absolute encoder, Minas A4, 3.6V 2000mAh
DVOP37300	Cable set (3m) interface, encoder and motor cable and connector kit of drive power
DVOP3811	DIN rail mounting kit for Minas E drivers
DVOP39200	Cable set (5m) interface, encoder and motor cable and connector kit of drive power
DVOP4420	Operating Console for Minas A4 and E servo drivers
DVOP4460	PANATERM Software for Minas servo drives, CD-ROM

MANUALS

Product number	Additional information / description
DVOP4210	Minas A4-series manual
DVOP4490	Minas A4P-series manual
DVOP3700	Minas E-series manual

Minas A4N manual is only available as PDF file from panasonic-electric-works.com

North America

Europe

Asia Pacific

China

Japan

Panasonic Electric Works

Please contact our Global Sales Companies in:

Europe

▶ Headquarters	Panasonic Electric Works Europe AG	Rudolf-Diesel-Ring 2, 83607 Holzkirchen, Tel. (08024) 648-0, Fax (08024) 648-111, www.panasonic-electric-works.com
▶ Austria	Panasonic Electric Works Austria GmbH PEW Electronic Materials Europe GmbH	Rep. of PEWDE, Josef Madersperger Str. 2, 2362 Biedermannsdorf, Tel. (02236) 26846, Fax (02236) 46133, www.panasonic-electric-works.at Ennsstadenstraße 9, 4470 Enns, Tel. (07223) 883, Fax (07223) 88333, www.panasonic-electronic-materials.com
▶ Benelux	Panasonic Electric Works Sales Western Europe B.V.	De Rijn 4, (Postbus 211), 5684 PJ Best, (5680 AE Best), Netherlands, Tel. (0499) 372727, Fax (0499) 372185, www.panasonic-electric-works.nl
▶ Czech Republic	Panasonic Electric Works Czech s.r.o.	Průmyslová 1, 34815 Planá, Tel. 374 799 990, Fax 374 799 999, www.panasonic-electric-works.cz
▶ France	Panasonic Electric Works Sales Western Europe B.V.	French Branch Office, B.P. 44, 91371 Verrières le Buisson CEDEX, Tél. 01 60135757, Fax 01 60135758, www.panasonic-electric-works.fr
▶ Germany	Panasonic Electric Works Deutschland GmbH	Rudolf-Diesel-Ring 2, 83607 Holzkirchen, Tel. (08024) 648-0, Fax (08024) 648-555, www.panasonic-electric-works.de
▶ Hungary	Panasonic Electric Works Europe AG	Magyarországi Közvettlen Kereskedelmi Képviselet, 1117 Budapest, Neumann János u. 1., Tel. 06 1 482 9258, Fax 06 1 482 9259, www.panasonic-electric-works.hu
▶ Ireland	Panasonic Electric Works UK Ltd.	Dublin, Tel. (01) 4600969, Fax (01) 4601131, www.panasonic-electric-works.co.uk
▶ Italy	Panasonic Electric Works Italia s.r.l. PEW Building Materials Europe s.r.l.	Via del Commercio 3-5 (Z.I. Ferlina), 37012 Bussolengo (VR), Tel. (045) 6752711, Fax (045) 6700444, www.panasonic-electric-works.it Piazza della Repubblica 24, 20154 Milano (MI), Tel. (02) 29005391, Fax (02) 29003466, www.panasonic-building-materials.com
▶ Nordic Countries	Panasonic Electric Works Nordic AB PEW Fire & Security Technology Europe AB	Sjöängsvägen 10, 19272 Sollentuna, Sweden, Tel. (08) 59476680, Fax (08) 59476690, www.panasonic-electric-works.se Citadellsvägen 23, 21118 Malmö, Tel. (040) 6977000, Fax (040) 6977099, www.panasonic-fire-security.com
▶ Poland	Panasonic Electric Works Europe AG	Przedstawicielstwo w Polsce, Al. Krakowska 4/6, 02-284 Warszawa, Tel. 22 338-11-33, Fax 22 338-12-00, www.panasonic-electric-works.pl
▶ Portugal	Panasonic Electric Works España S.A.	Portuguese Branch Office, Avda Adelino Amaro da Costa 728 R/C J, 2750-277 Cascais, Tel. (21) 4812520, Fax (21) 4812529
▶ Spain	Panasonic Electric Works España S.A.	Barajas Park, San Severo 20, 28042 Madrid, Tel. (91) 3293875, Fax (91) 3292976, www.panasonic-electric-works.es
▶ Switzerland	Panasonic Electric Works Schweiz AG	Grundstrasse 8, 6343 Rotkreuz, Tel. (041) 7997050, Fax (041) 7997055, www.panasonic-electric-works.ch
▶ United Kingdom	Panasonic Electric Works UK Ltd.	Sunrise Parkway, Linford Wood, Milton Keynes, MK14 6LF, Tel. (01908) 231555, Fax (01908) 231599, www.panasonic-electric-works.co.uk

North & South America

▶ USA	PEW Corporation of America	629 Central Avenue, New Providence, N.J. 07974, Tel. 1-908-464-3550, Fax 1-908-464-8513, www.pewa.panasonic.com
--------------	-----------------------------------	---

Asia Pacific/China/Japan

▶ China	Panasonic Electric Works (China) Co., Ltd.	Level 2, Tower W3, The Towers Oriental Plaza, No. 2, East Chang An Ave., Dong Cheng District, Beijing 100738, Tel. (010) 8518-5988, Fax (010) 8518-1297
▶ Hong Kong	Panasonic Electric Works (Hong Kong) Co., Ltd.	RM1205-9, 12/F, Tower 2, The Gateway, 25 Canton Road, Tsimshatsui, Kowloon, Hong Kong, Tel. (0852) 2956-3118, Fax (0852) 2956-0398
▶ Japan	Matsushita Electric Works, Ltd.	1048 Kadoma, Kadoma-shi, Osaka 571-8686, Japan, Tel. (06) 6908-1050, Fax (06) 6908-5781, www.mew.co.jp/e-acg/
▶ Singapore	Panasonic Electric Works Asia Pacific Pte. Ltd.	101 Thomson Road, #25-03/05, United Square, Singapore 307591, Tel. (06255) 5473, Fax (06253) 5689