



FEATURES

- **Small size**
The smallest double make type relay
12.0(W)×15.5(L)×13.9(H) mm
.472(W)×.610(L)×.547(H) inch
- **Pattern design simplification**
Simplified pattern design is possible because, while double make construction is employed, the external COM terminal is single.

- **Standard terminal pitch employed**
The terminal array used is identical to that used in JJM relays(1c type).
- **Plastic sealed type**
Plastically sealed for automotive cleaning.

TYPICAL APPLICATIONS

Car alarm system flashing lamp etc.

TYPES

Contact arrangement	Coil voltage	Part No.
Double make contact	12 V DC	AJJM831

Standard packing; Carton (tube): 50 pcs.; Case: 1,000 pcs.

RATING

1. Coil data

Nominal coil voltage	Pick-up voltage (at 20°C 68°F)	Drop-out voltage (at 20°C 68°F)	Nominal operating current [±10%] (at 20°C 68°F)	Coil resistance [±10%] (at 20°C 68°F)	Nominal operating power (at 20°C 68°F)	Usable voltage range
12V DC	Max. 6.9 V DC (Initial)	Min. 1.0V DC (Initial)	83.3 mA	144Ω	1,000 mW	10 to 16V DC

Note: Other pick-up voltage types are also available. Please contact us for details.

2. Specifications

Characteristics	Item	Specifications	
Contact	Arrangement	Double make contact	
	Contact resistance (Initial)	Typ 10mΩ (By voltage drop 6V DC 1A)	
	Contact material	Ag alloy (Cadmium free)	
Rating	Nominal switching capacity (lamp load)	12A 14V DC (at 2 × 6A)	
	Max. carrying current (12V DC)*3	2 × 6 A at 20°C 68°F, 2 × 4 A at 85°C 185°F	
	Nominal operating power	1,000 mW	
	Min. switching capacity (resistive load)*1	1A 12V DC	
Electrical characteristics	Insulation resistance (Initial)	Min. 100 MΩ (at 500V DC)	
	Breakdown voltage (Initial)	Between open contacts	500 Vrms for 1 min. (Detection current: 10mA)
		Between contacts and coil	500 Vrms for 1 min. (Detection current: 10mA)
	Operate time (at nominal voltage)	Max. 10ms (at 20°C 68°F, excluding contact bounce time) (Initial)	
	Release time (at nominal voltage)	Max. 10ms (at 20°C 68°F, excluding contact bounce time) (Initial)	
Mechanical characteristics	Shock resistance	Functional	Min. 100 m/s ² {10G} (Half-wave pulse of sine wave: 11ms; detection time: 10μs)
		Destructive	Min. 1,000 m/s ² {100G} (Half-wave pulse of sine wave: 6ms)
	Vibration resistance	Functional	10 Hz to 100 Hz, Min. 44.1 m/s ² {4.5G} (Detection time: 10μs)
		Destructive	10 Hz to 500 Hz, Min. 44.1 m/s ² {4.5G}, Time of vibration for each direction; X, Y direction: 2 hours, Z direction: 4 hours
Expected life	Mechanical	Min. 10 ⁷ (at 120 cpm)	
	Electrical	<Lamp load> Min. 10 ⁵ [21W × 6 lamps (2 × 3 lamps) at 14 V DC, operating frequency: 1s ON, 14s OFF]	
Conditions	Conditions for operation, transport and storage*2	Ambient temperature: -40°C to +85°C -40°F to +185°F, Humidity: 5% R.H. to 85% R.H. (Not freezing and condensing at low temperature), Air pressure: 86k Pa to 106k Pa	
Mass		Approx. 5g .176 oz	

Notes:

*1. This value can change due to the switching frequency, environmental conditions, and desired reliability level, therefore it is recommended to check this with the actual load.

*2. The upper operation ambient temperature limit is the maximum temperature that can satisfy the coil temperature rise value. Refer to "6. Usage, Storage and Transport Conditions" in [AMBIENT ENVIRONMENT section in Relay Technical Information](#).

Please inquire if you will be using the relay in a high temperature atmosphere (110°C 230°F).

*3. Depends on connection conditions. Also, this does not guarantee repeated switching. We recommend that you confirm operation under actual conditions.

JJ-M(2w)

REFERENCE DATA

1. Coil temperature rise

Sample: AJJM831, 6pcs.
 Point measured: Inside the coil
 Contact carrying current: 2 × 6A, 2 × 4A
 Ambient temperature: Room temperature, 85°C
 185°F

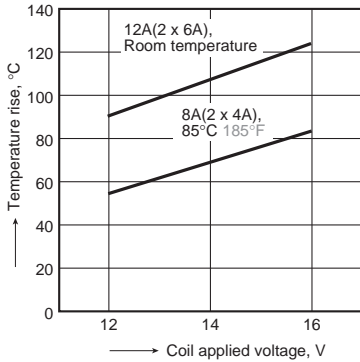

2. Ambient temperature and operating voltage range

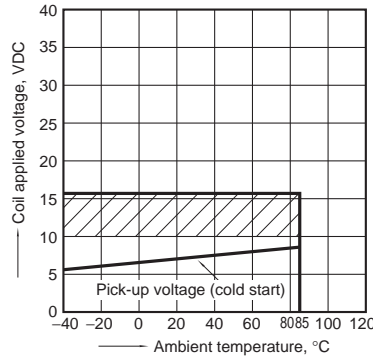

3. Distribution of pick-up and drop-out voltage

Sample: AJJM831, 50pcs.

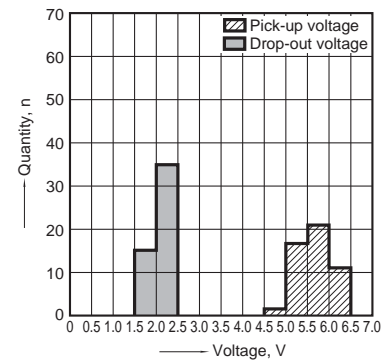

4. Distribution of operate time

Sample: AJJM831, 50pcs.

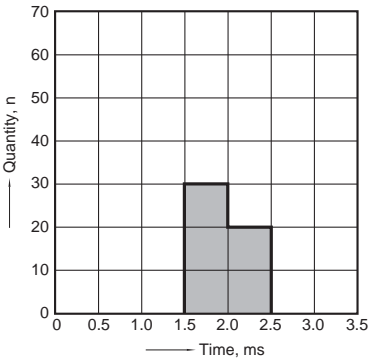

5. Distribution of release time

Sample: AJJM831, 50pcs.

* Without diode

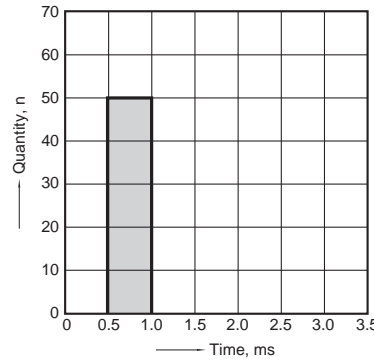

6. Electrical life test (Lamp load)

Sample: AJJM831, 6pcs.
 Load: 6 × 21W, inrush 48A, steady 5.5A
 Operating frequency: (ON 1s, OFF 14s)
 Ambient temperature: Room temperature

Circuit:

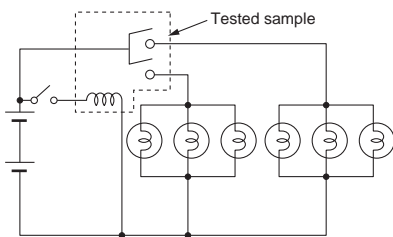

Load current waveform

Current value per contact on one side
 Inrush current: 48A, Steady current: 5.5A

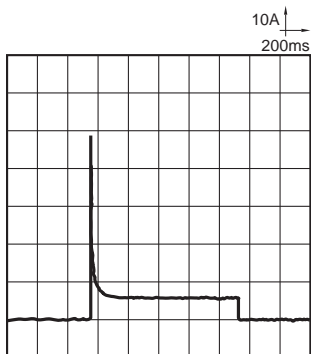

Change of pick-up and drop-out voltage

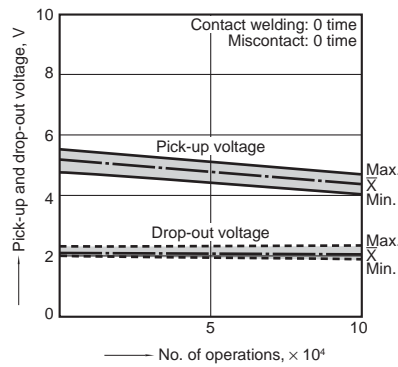

Change of contact resistance

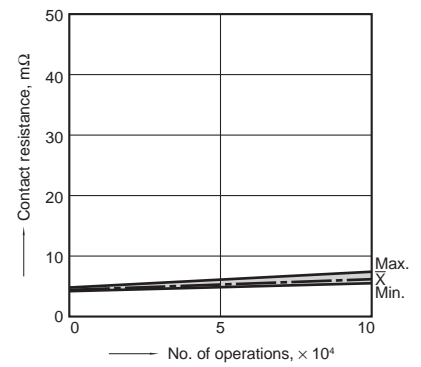

DIMENSIONS (mm inch)

Download [CAD Data](#) from our Web site.

CAD Data



External dimensions

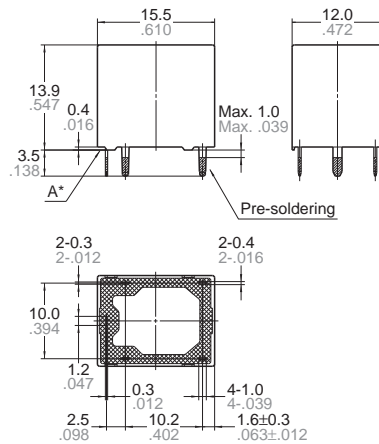

PC board pattern (Bottom view)

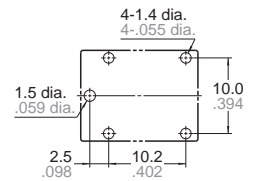

Tolerance: $\pm 0.1 \pm 0.004$

Schematic (Bottom view)

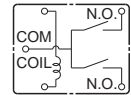

<u>Dimension:</u>	<u>General tolerance</u>
Max. 1mm .039 inch:	$\pm 0.1 \pm 0.004$
1 to 3mm .039 to .118 inch:	$\pm 0.2 \pm 0.008$
Min. 3mm .118 inch:	$\pm 0.3 \pm 0.012$

* Dimensions (thickness and width) of terminal in this catalog is measured before pre-soldering. Intervals between terminals is measured at A surface level.

EXAMPLE OF CIRCUIT

Control circuit for turn signal lights (security system)

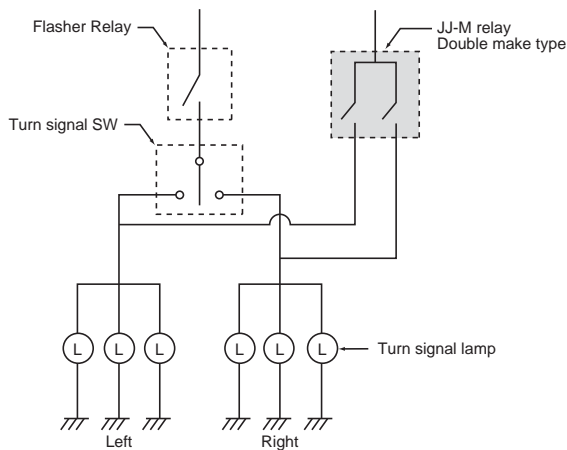

For Cautions for Use, see [Relay Technical Information](#).