

The innovative SBX[®] connectors provide cost-effective reliability, design flexibility and safety for your products' manufacture, installation and maintenance.

APP's 2 pole connector is available with a 350 amp rating, 600 Volts continuous AC or DC operation. There are SBX[®] connectors for many applications and wire sizes, 2/0 to 300 mcm (67.4 mcm to 152 mm). Mechanical keys ensure connectors will only mate with connectors of the same color. Different color housings are selected to identify voltages, thus preventing mismatching of the power supply system.

FEATURES

- **Mechanical Keyed Housings**
Prevents accidental mating of components operating at different voltage levels
- **Auxiliary Contacts Kits**
Provides ability to incorporate a secondary circuit
- **Optional Mechanical Release**
Aids mating and unmating for high cycle battery charging



PRODUCT SPECIFICATIONS

Connector Model	SBX [®] 350	Connector Model	SBX [®] 350
Current Rating (Amperes)*	350*	Life	
Voltage Ratings (AC/DC)	600*	a. No load (mating cycles)	To 10,000
Contact Barrel Wire Size (AWG) (mm ²)	2/0 to 300 mcm 67.4 to 150	b. Under Load (Hot Plug 250 mating cycles @ 120V)	100A*
Maximum Wire Insulation Diameter (inches) (mm)	1.10 27.9	Connection/Disconnect (lbf) (N)	30 133
Average Contact Resistance (micro-ohms)*	50	Operating Temperature (°C)** (°F)	-20° to 105° -4° to 221°
Dielectric Withstanding Voltage (AC/DC)	2,200	Flammability Rating of Housing Material	UL94 V-0
Contact Retention Force (lbf) (N)	500 2,224		



* UL Rated for 65°C largest wire or cable size

** Contact factory for higher temperature rated connector

ORDERING INFORMATION

2 Pole Housing, 350 amp Contacts, & Auxiliary Contacts

Part Number	Housing Color	Wire AWG	Wire sq. mm
6340G1	Gray	2/0	67.4
6340G2	Gray	3/0	85.0
6340G3	Gray	4/0	107.2
6340G5	Gray	300mcm	152.0
6341G1	Blue	2/0	67.4
6341G2	Blue	3/0	85.0
6341G3	Blue	4/0	107.2
6341G5	Blue	300mcm	152.0
6342G1	Red	2/0	67.4
6342G2	Red	3/0	85.0
6342G3	Red	4/0	107.2
6342G5	Red	300mcm	152.0
6343G1	Green	2/0	67.4
6343G2	Green	3/0	85.0
6343G3	Green	4/0	107.2

2 pole housing, 350 amp contacts, & auxiliary contacts continued

Part Number	Housing Color	Wire AWG	Wire sq. mm
6343G5	Green	300mcm	152.0
6359G1	Black	2/0	67.4
6359G2	Black	3/0	85.0
6359G3	Black	4/0	107.2
6359G5	Black	300mcm	152.0
6360G1	Yellow	2/0	67.4
6360G2	Yellow	3/0	85.0
6360G3	Yellow	4/0	107.2
6360G5	Yellow	300mcm	152.0
6368G1	Orange	2/0	67.4
6368G2	Orange	3/0	85.0
6368G3	Orange	4/0	107.2
6368G5	Orange	300mcm	152.0

2 Pole Housing & 350 amp Contacts

Part Number	Housing Color	Wire AWG	Wire sq. mm
6345G1	Gray	2/0	67.4
6345G2	Gray	3/0	85.0
6345G3	Gray	4/0	107.2
6345G5	Gray	300mcm	152.0
6346G1	Blue	2/0	67.4
6346G2	Blue	3/0	85.0
6346G3	Blue	4/0	107.2
6346G5	Blue	300mcm	152.0
6347G1	Red	2/0	67.4
6347G2	Red	3/0	85.0
6347G3	Red	4/0	107.2
6347G5	Red	300mcm	152.0
6348G1	Green	2/0	67.4
6348G2	Green	3/0	85.0
6348G3	Green	4/0	107.2
6348G5	Green	300mcm	152.0

Note: For additional colors please contact customer service

HEADQUARTERS: Anderson Power Products[®], 13 Pratts Junction Road, Sterling, MA01564-2305 USA T:978-422-3600 F:978-422-3700

EUROPE: Anderson Power Products[®] Ltd., Unit 3, Europa Court, Europa Boulevard, Westbrook, Warrington, Cheshire, WA5 7TN United Kingdom T: +44 (0) 1925 428390 F: +44 (0) 1925 520203

ASIA/PACIFIC: IDEAL Anderson Asia Pacific Ltd., Unit 922-928 Topsail Plaza, 11 On Sum Street, Shatin N.T., Hong Kong T: +(852) 2636 0836 F: +(852) 2635 9036

CHINA: IDEAL Anderson Technologies (Shenzhen) Ltd., Block A8 Tantou Western Industrial Park, Songgang Baoan District, Shenzhen, P.R. China 518105 T: +(86) 755 2768 2118 F: +(86) 755 2768 2218

TAIWAN: IDEAL Anderson Asia Pacific Ltd., Taiwan Branch, 4F.-2, No.116, Dadun 20th St., Situn District, Taichung City 407, Taiwan (R.O.C.) T: +(886) 4 2310 6451 F: +(886) 4 2310 6460

www.andersonpower.com

ORDERING INFORMATION

continued

2 Pole Housing & 350 amp Contacts

Part Number	Housing Color	Wire	
		AWG	sq. mm
6363G2	Black	3/0	85.0
6363G3	Black	4/0	107.2
6363G5	Black	300mcm	152.0
6364G1	Yellow	2/0	67.4
6364G2	Yellow	3/0	85.0
6364G3	Yellow	4/0	107.2
6364G5	Yellow	300mcm	152.0
6369G1	Orange	2/0	67.4
6369G2	Orange	3/0	85.0
6369G3	Orange	4/0	107.2
6369G5	Orange	300mcm	152.0

2 Pole Housing, 350 amp 35mm Contacts

Part Number	Housing Color	Wire
		sq. mm
6345G6	Gray	35
6346G6	Blue	35
6347G6	Red	35
6348G6	Green	35
6363G6	Black	35
6364G6	Yellow	35
6369G6	Orange	35

2 Pole Housing, 350 amp 35mm Contacts & Auxiliary Contacts

Part Number	Housing Color	Wire
		sq. mm
6340G6	Gray	35
6341G6	Blue	35
6342G6	Red	35
6343G6	Green	35
6359G6	Black	35
6360G6	Yellow	35
6380G6	Orange	35

Contacts

Part Number	Description	- Wire -	
		AWG	sq. mm
6354	Contact set (2)	2/0	67.4
6355	Contact set (2)	3/0	85.0
6356	Contact set (2)	4/0	107.2
6358	Contact set (2)	300 mcm	152.0
6394	Contact set (2)-thin wall	N/A	35

Bushings

Part Number	Description	- Wire -	
		AWG	sq. mm
5918	Use with 6354 contact	2/0 to 1/0	67.43 to 53.5
5920	Use with 6394 contact	N/A	35 to 16mm
5687	Use with 6354 contact & 5918 bushing	1/0 to #1	53.5 to 42.4
5690	Use with 6354 contact & 5918 bushing	1/0 to #2	53.5 to 33.6
5693	Use with 6354 contact & 5918 bushing	1/0 to #4	53.5 to 21.2
5663	Use with 6354 contact & 5918 bushing	1/0 to #6	53.5 to 13.3
5648	Use with 6354 contact & 5918 bushing	1/0 to #10	53.5 to 5.3

Housings Only

Part Number	Color
	6350
6351	Blue
6352	Red
6353	Green
6361	Black
6362	Yellow
6339	Orange

Accessories

Part Number	Description
995G2	"A" frame handle with hardware - Gray
993G1	Manual release-battery bracket with hardware
994G1	Manual release-charger/truck bracket with hardware
911G2	Cable clamps-use alone with manual release or "A" frame handle
1x2 Auxiliary Kit	
6305G1	Powerpole auxiliary contact kit with contact #1331
6310G1	Auxiliary contact kit with contact #1332
1x4 Pin & Socket Auxiliary Kit	
6367G1	#16/12 (1.31/3.31mm) - for battery - Pin
6366G2	#16/12 (1.31/3.31mm) - for charger & truck-tube
440G1	Kit #14 - #16 AWG contacts
440G2	Kit #16 - #20 AWG contacts
440G3	Kit #12 AWG contacts

DIMENSIONS

Housing

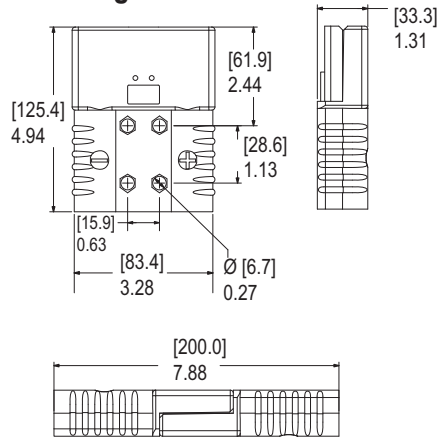

TEMPERATURE CHARTS

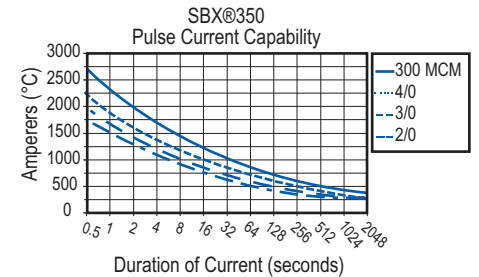
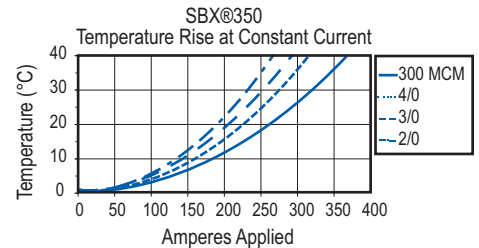

TOOLING

Contact	Wire Size AWG (mm)	Insertion / Extraction Tool	Hand Tool	Hydraulic Tool	Pneumatic Tool	Die	Locator
6384G2	35mm	969P1	N/A	1368	1387G2	1303G2	1304G2
6384G1	1/0	969P1	N/A	1368	1387G1	1388G3	1389G3
441G1,G2 & G3 1x4 Auxiliary's	#12 / #20 (2.5 / 0.5 mm)	PM1002G1 & PM1003G1	TM001 M22520/1-01 & PM1000G1 Four Indent	N/A	TP0001	NA	TL0004 (to be used with TM001)
6344 1x2 PP Auxiliary Kit	#12 / 16 (2.5 / 1.0)	111038G2	1309G2 1309G8*	N/A	1367G1	NA	NA
6367G1 & 6366G2 1x2 Pin & Socket Auxiliary's	#14 / 16 (1.5 / 1.0)	NA	1309G1	NA	NA	NA	NA

NOTE: When using bushings, see tooling section on website, www.andersonpower.com.