



An **IDEAL** Company

Assembly Instructions for Power Drawer Series

35 amp and 75 amp



These assembly instructions include the instructions for wire termination, contact insertion, contact removal, PCB mount, and panel mounting of the Anderson Power Products 75 and 35 amp Power Drawer connectors.

Available Tools

- Contact Insertion/Removal Tool
- Crimp Tool #20-#8 AWG

Wire Termination

Anderson Power Products recommends the following tools for wire termination. Crimping by other means may produce high resistance joints:

Wire Size AWG	Type	MIL-STD
12 to 24	Crimp Tool turret head/locator	M22520/1-01 M22520/1-02
8	Crimp Tool turret head locator	M22520/23-01 M22520/23-02 M22520/1-09

1. Strip the wire according to the table below:

Contact Size	Wire Size AWG	Length ±.020 (.51)	
		In	mm
#20	#24-#20	.210	5.33
#16	#20-#16	.270	6.86
#12	#14-#12	.270	6.86
#8	#10-#8	.500	12.70

2. Place the contact mating end first into the crimp tool. Insert the wire all the way into the open crimp barrel making sure that all strands are included. Squeeze the tool handles until the cycle completes and the tool handles release. Remove the wire and crimped contact.

Contact Insertion and removal

1. Tools

Insertion and removal of the wire crimped contacts from the housing requires a contact removal tool.

- #20 contact M81969/14-11
- #12 contact M81969/14-04
- #8 contact M81969/14-12

2. Contact Insertion

The Anderson Power Drawer connector has pre-loaded contact retention clips, housings. The contacts are loaded into the housing from the bottom. Line up the contact with the appropriate hole in the connector. Insert the mating end of the connector into the hole first. Slide the tool over the wire and butt it against the shoulder of the contact. Push the contact into the housing until it bottoms out. Squeeze the tool slightly and remove. Give a gentle pull on the wire to ensure that the retention clips are fully engaged.

3. Contact Removal

To remove a contact, squeeze the tool, insert it into the appropriate hole from the bottom side of the connector, then allow the tool to expand out. The expanded tool should compress the contact retention clips, allowing the contact to be removed with a gentle pull on the wire. Once the contact is disengaged, remove the insertion/extraction tool.

Note: PCB contacts are not removable from the housing once installed.

Connector Mounting

1. Panel Float Mounting

Float mounting on a panel is achieved with the use of shoulder screws. The shoulder screws used should match the following diagram:

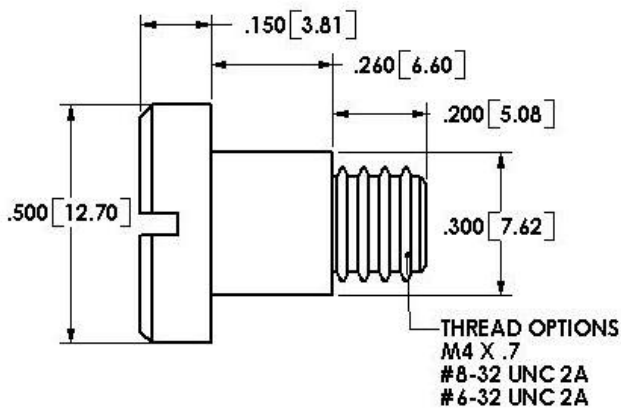

2. Panel Fixed Mounting

The Power Drawer connectors can be fixed mounted to a panel by means of a screw and washer through the mounting slots on the top and bottom of the connector. No special hardware is required to mount the connector in this manner.

Panel Cut-out Dimensions

The sketch below shows the suggested panel cut-out dimensions for the 075 and 035 Power Drawer.

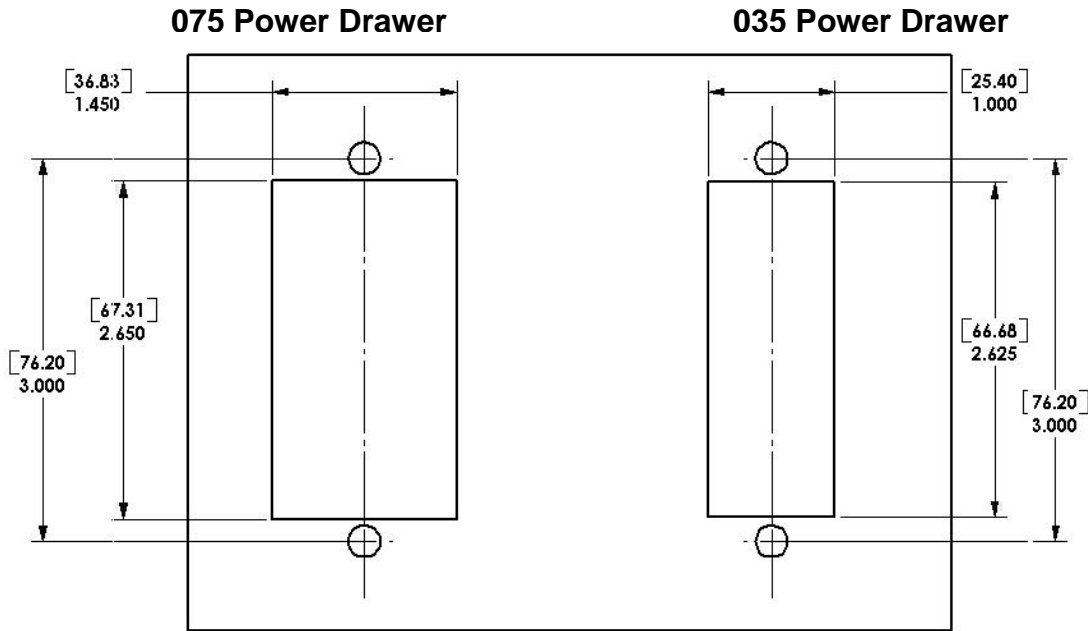

PCB Mounting

When mounting to a PCB, the standoffs on the bottom of the connector should be seated directly on the board. The standoffs will allow a .020 (.51) gap between the bottom flange of the connector and the board. This gap is essential for proper soldering. It is also advisable that hold downs are used for stability during the soldering process. The PCB hole layouts for each connector are shown below.

035 Power Drawer #12 and #20 AWG

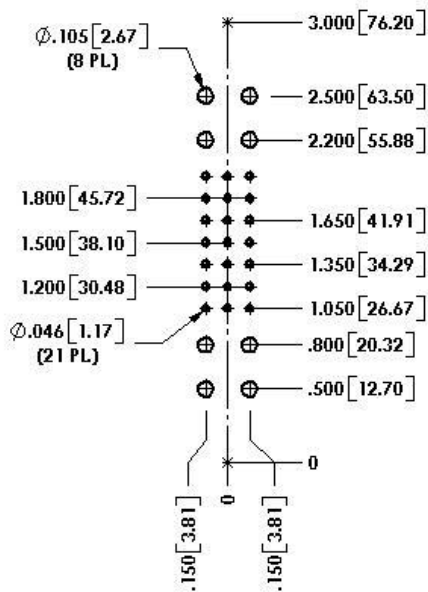

075 Power Drawer #8, #12, and #20

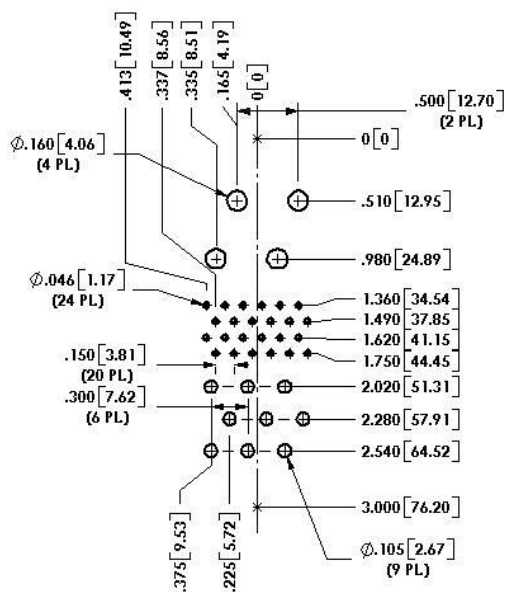

Connector Engagement

Power Drawer connectors are fully mated when the gap between the pin and socket housings is less than or equal to .50 (12.7) for the 075 Power Drawer connector and .40 (10.2) for the 035 Power Drawer connector, as shown in the diagram below. The connectors must be allowed to mate to this distance to ensure full engagement of the pin and socket contacts.

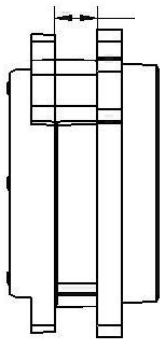

.50 (12.7) 075 Power Drawer
.40 (10.2) 035 Power Drawer

TRADEMARKS: "Anderson Power Products" is a registered U.S. and foreign trademark of Anderson Power Products.

HEADQUARTERS: Anderson Power Products®, 13 Pratts Junction Road, Sterling, MA 01564-2305 USA T:978-422-3600 F:978-422-0128
www.andersonpower.com