

THE INFORMATION CONTAINED IN THIS DRAWING IS THE SOLE PROPERTY OF ANDERSON POWER PRODUCTS. ANY REPRODUCTION IN PART OR WHOLE WITHOUT THE WRITTEN PERMISSION OF ANDERSON POWER PRODUCTS IS PROHIBITED.

Copyright 2005

ANDERSON POWER PRODUCTS RESERVES THE RIGHT TO ALTER PRODUCT TYPES, THEIR TECHNICAL DATA, DIMENSION, STYLE AND ACCESSORIES WITHOUT PRIOR NOTIFICATION.

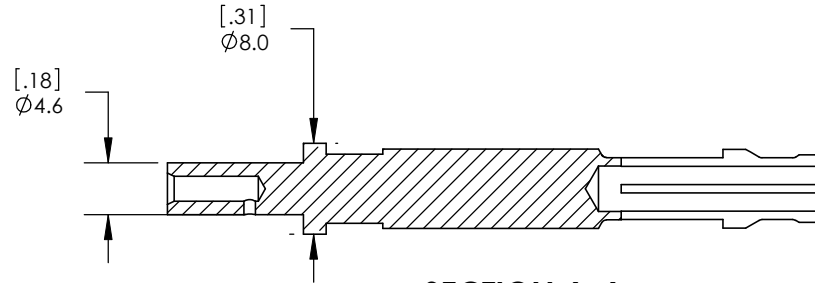
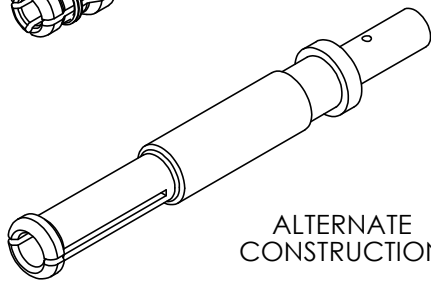
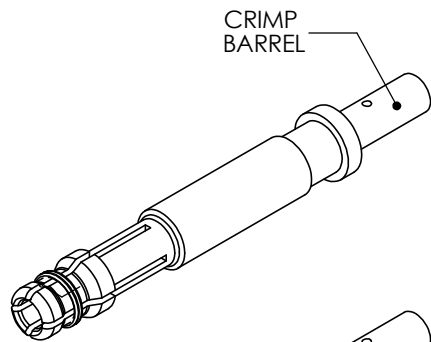
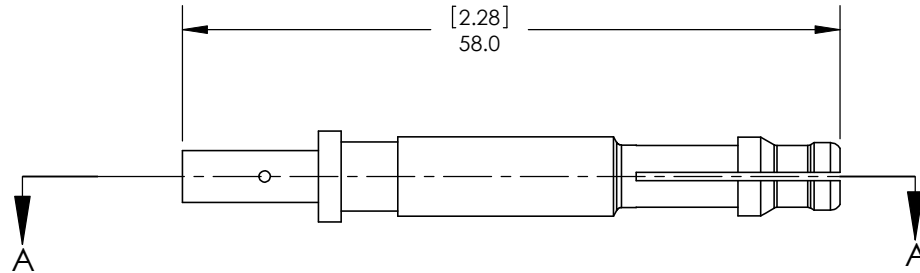

**SECTION A-A**

DIMENSIONS ARE IN:		MM[INCH]
UNLESS OTHERWISE STATED		
TOLERANCES:		
DECIMALS (INCH)	DECIMALS (MM)	ANGLES
.XX ±.02	.X ±.5	±2°
SURFACE FINISH:		
MACHINED	128 [3.2]	
MOLDED	64 [1.6]	
MATERIAL: COPPER ALLOY		
FINISH: SILVER PLATE		

APPROVALS	
DRAWN	AMP 5/11/05
CHECKED	DJD 5/11/05
MFG APP	CHB 5/11/05
QC APP	UFN 5/11/05
ENG APP	DAM 5/11/05

	<b>ANDERSON POWER PRODUCTS</b>	
TITLE	SALES OUTLINE EBC DIN AUX. SOCKET CONTACT CAT. NO. 320-23 (14/18 AWG)	
SIZE	DWG NO.	REV.
A/A4	320-23 S1	1

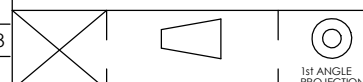

-CAD GENERATED DRAWING-  
DO NOT MANUALLY UPDATE  
DO NOT SCALE

1	ECRN 14292 -ADD ALTERNATE CONSTRUCTION	AMS	07/25/08
REV.	DESCRIPTION OF CHANGES	APPROVED	DATE

SCALE	CADFILE	SHEET
NONE	02318	1 OF 1