

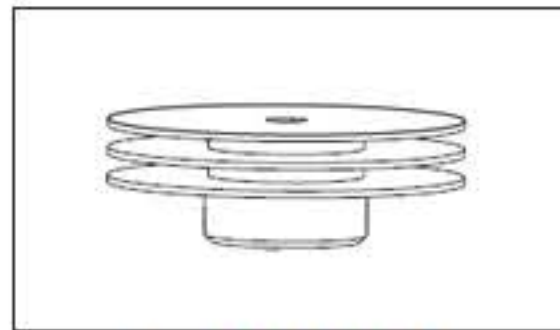

5-1542004-8 Product Details

Share Print Email



5-1542004-8

Heat Sink Assemblies

Converted to EU RoHS/ELV Compliant (Statement of Compliance)

Product Highlights:

- Heat Sink
- BGA
- Package Size = 25 [.985] mm [in]
- For Use With BGA Semiconductor Packages
- Power Air Velocity Thermal Resistance

[View all Features](#)

Quick Links

- ▶ Pricing & Availability
- ▶ Search for Tooling
- ▶ Product Feature Selector
- ▶ Contact Us About This Product

TE Internal Number: 5-1542004-8

Active

[Add to My Part List](#) [Request Sample](#) [Find Similar Products](#) [Buy Product](#)

Documentation & Additional Information	
<p>Product Drawings:</p> <ul style="list-style-type: none"> • 25mm HS ASS'Y (HTS768-U) (PDF, English) <p>Catalog Pages/Data Sheets:</p> <ul style="list-style-type: none"> • None Available <p>Product Specifications:</p> <ul style="list-style-type: none"> • None Available <p>Application Specifications:</p> <ul style="list-style-type: none"> • None Available <p>Instruction Sheets:</p> <ul style="list-style-type: none"> • None Available <p>CAD Files:</p> <ul style="list-style-type: none"> • None Available 	<p>Additional Information:</p> <ul style="list-style-type: none"> • Product Line Information <p>Additional Product Images:</p> <ul style="list-style-type: none"> • Line Drawing • Thermal Resistance Chart <p>Related Products:</p> <ul style="list-style-type: none"> • Tooling

[List all Documents](#)

Product Features (Please use the Product Drawing for all design activity)	
<p>Product Type Features:</p> <ul style="list-style-type: none"> • Product Type = Heat Sink • Device Type = BGA • Heat Sink Type = 3 Fin Radial • Finish = Black Anodize <p>Dimensions:</p> <ul style="list-style-type: none"> • Diameter (mm [in]) = 34.92 [1.375] • Height (mm [in]) = 11.86 [0.467] <p>Body Features:</p> <ul style="list-style-type: none"> • Package Size (mm [in]) = 25 [.985] • Material = Aluminum 	<p>Housing Features:</p> <ul style="list-style-type: none"> • UL Flammability Rating = UL 94V-0 <p>Industry Standards:</p> <ul style="list-style-type: none"> • RoHS/ELV Compliance = RoHS compliant, ELV compliant • Lead Free Solder Processes = Not relevant for lead free process • RoHS/ELV Compliance History = Converted to comply with RoHS directive <p>Conditions for Usage:</p> <ul style="list-style-type: none"> • For Use With = BGA Semiconductor Packages <p>Other:</p> <ul style="list-style-type: none"> • Brand = TE Connectivity • Line = ChipCoolers • Comment = Mounting clip does not increase overall heat sink height.; Heat sink assembly includes Four Leg Standard Clip, Part Number 1542026-1.

Corporate Information

- [About TE](#)
- [Investors](#)
- [News Room](#)
- [Supplier Portal](#)
- [Careers](#)
- [Terms & Conditions](#)
- [Privacy Policy](#)

Quick Links

- [Distributor Inventory](#)
- [Product Cross Reference](#)
- [Documents & Drawings](#)
- [Product Compliance Support Center](#)
- [Site Map](#)

Customer Support

- [Email or Chat With Us](#)
- [Find a Phone Number](#)
- [Knowledge Base](#)
- [Manage Your Account](#)

Keep Me Informed

