

DESCRIPTION	PART NUMBER
SMA Right-Angle Cable Plugs	1311055-1
	1051156-1
	1311563-1
	1056931-1
	1313729-1
	1088312-1
	1051157-1
	1223286-1
	1313559-1
	1313278-1
	1082030-1

Figure 1

1. INTRODUCTION

The SMA Right-Angle Cable Plugs listed in Figure 1 were designed to be soldered onto .141 or .085 semi-rigid coaxial cable, or .141 semi-rigid microporous cable using the following tool:

TOOL DESCRIPTION	PART NUMBER	
	TE CONNECTIVITY	M/A-COM
Locator Tool	1055451-1	2098-5218-0217 (T-2367)

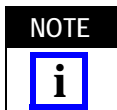

Dimensions in this instruction sheet are in millimeters [with inches in brackets]. Figures are not drawn to scale.

Reasons for reissue of this instruction sheet are provided in Section 4, REVISION SUMMARY.

2. DESCRIPTION

The plug connector consists of a housing subassembly and disc. See Figure 1.

3. ASSEMBLY PROCEDURE



Follow safety precautions included with the tools used for assembly.

- Strip the cable to the dimensions shown in Figure 2.
- Secure the threaded end of the housing subassembly onto the locator tool. Secure the assembly in a small bench vise.
- Tin the cable center conductor.



If using microporous cable, do not allow flux or solvent on or near the cable dielectric.

- Insert the center conductor into the housing subassembly. See Figure 3, Detail A. Make sure that the conductor is positioned in the slot of the contact inside the housing and the cable dielectric is against the contact. See Figure 3, Detail B.
- Place the soldering iron on the tip of the contact, and solder.
- Solder the housing subassembly to the cable. Refer to Figure 4, Detail A.

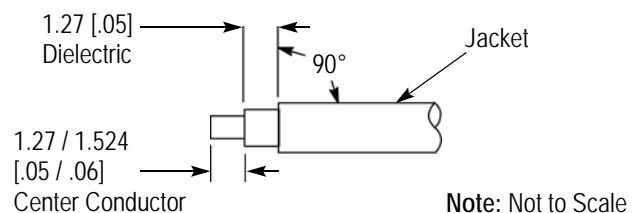

Figure 2

- Refer to Figure 4, Detail B, and install the disk onto the housing subassembly according to the following preferred option:

Option 1 - Press the disk into the opening in the housing subassembly, and secure with epoxy. Do not allow epoxy to enter the housing subassembly.

Option 2 - Tin the perimeter of the opening in the housing subassembly. Do not allow solder to enter the housing subassembly. Press the disk into the opening, then apply heat to the disk.

- Remove the locator tool.

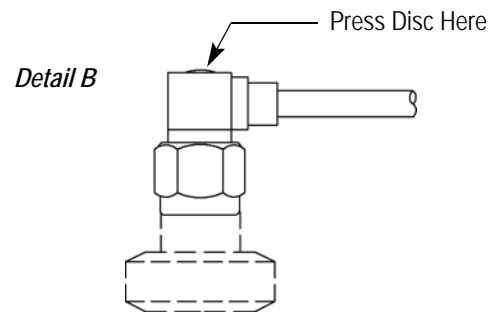
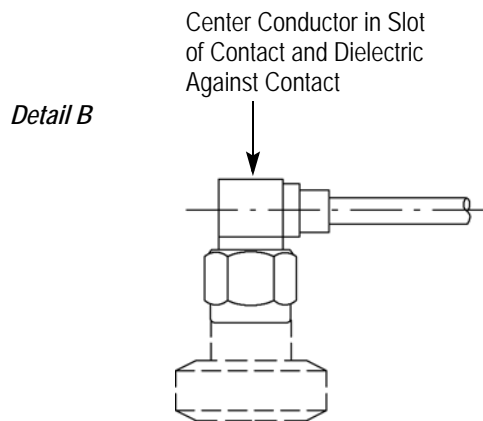
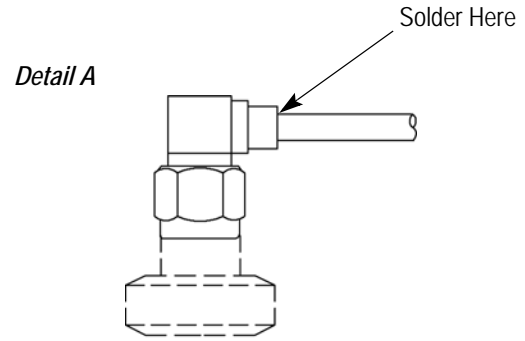
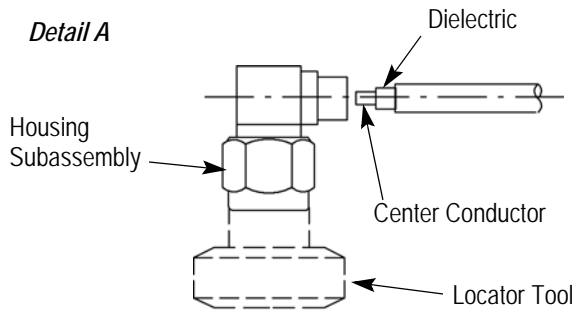

Figure 3

Figure 4

4. REVISION SUMMARY

Updated document to corporate requirements.