



Board-to-Board Vertical Receptacles and Headers

Product Facts

- Surface-mount products for parallel board-to-board applications, as well as right-angle board-to-board and cable-to-board applications
- High density .050 x .050 [1.27x1.27] centerline grid
- Three board-to-board stack heights: .250 [6.35], .320 [8.13] and .390 [9.91]
- Non-protrusive metallic holddowns
- Reliable dual beam receptacle contacts for redundant contact
- Duplex plated receptacle and post contacts; gold plated on mating areas, tin-lead plated on tails
- Compatible with standard surface-mount processing (VPR and IR)
- Receptacle and header allow for drainage of processing fluids
- Tape and reel packaging available, contact Tyco Electronics for details
- Polarized header and receptacle assemblies
- Sizes of 10, 20, 30, 40, 50, 60, 70, 80 and 100 positions
- Recognized under the Component Program of Underwriters Laboratories Inc., File No. E28476 
- Certified by Canadian Standards Association File No. LR7189 

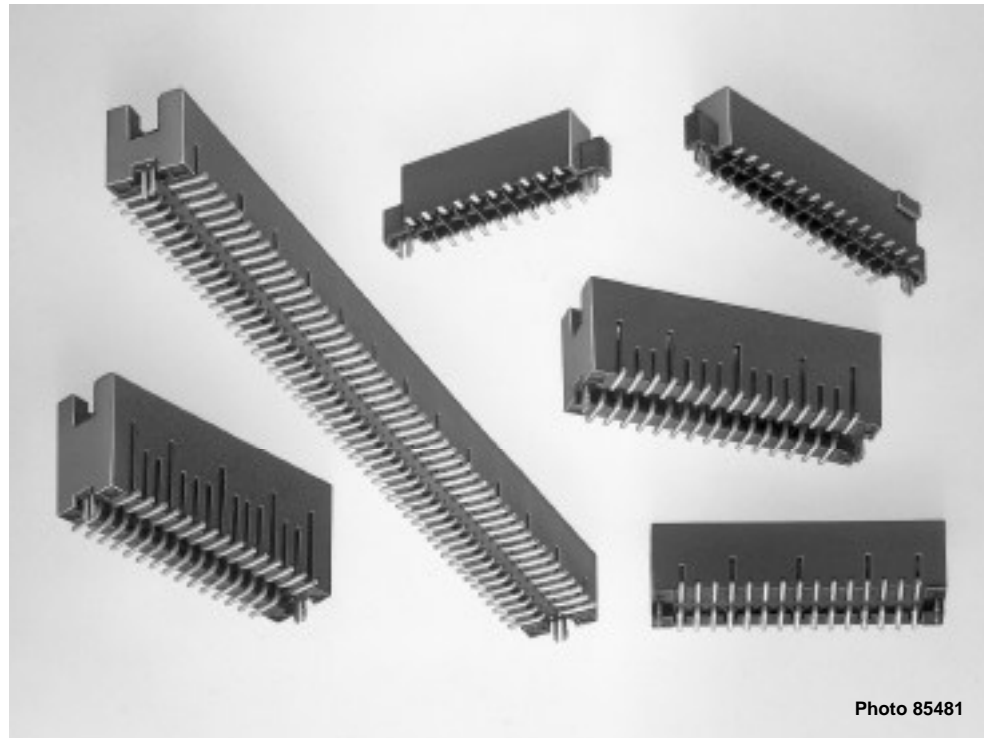

Photo 85481

AMPMODU 50/50 Grid Vertical Headers and Receptacles are designed for parallel board-to-board stacking in high density applications.

Right-angle board-to-board and cable-to-board applications are also possible, since the vertical receptacles also mate with non-latching right-angle headers (page 17) and the vertical headers also mate with non-latching cable connectors.

Available are double row, vertical shrouded headers and receptacles in sizes ranging from 10 through 100 positions (in 10 position increments).

Parallel board-to-board stack heights of .250 [6.35], .320 [8.13] and .390 [9.91] are achievable by selection of the appropriate header. The receptacle is the same for all three stack height headers.

Non-protrusive metallic holddowns are designed for use in .062 [1.57] or thicker

PC boards and allow surface mounting to both sides of the board. In addition to providing retention during processing, the holddowns are soldered during reflow and therefore provide long term strain relief for the lead solder joints.

AMPMODU 50/50 Grid Vertical Headers and Receptacles are compatible with standard surface-mount processes; IR (infrared) and VPR (vapor phase reflow). The surface-mount connectors have been designed so that dimensioning, tolerances, referenced datums, holddown characteristics

and packaging methods result in a system that is compatible with robotic assembly.

The headers and receptacles feature polarization to prevent misalignment.

Three Board Stack Heights

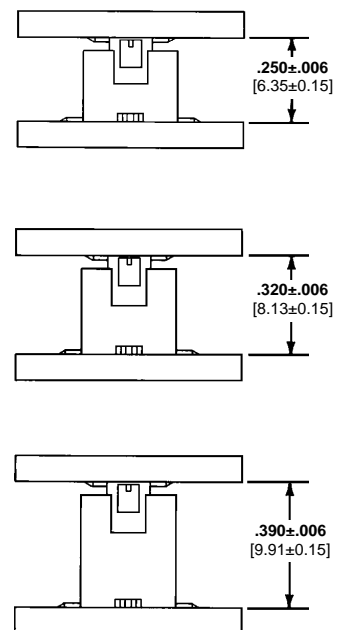

Non-Protrusive Metallic Holddowns

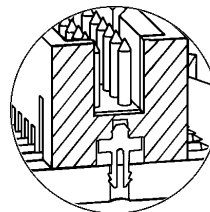

**Board-to-Board Vertical Receptacles, Double Row, .050 x .050
[1.27 x 1.27] Centerline**

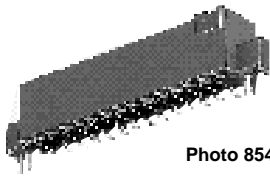

Photo 85482

Material and Finish:

Housing—Glass-filled thermoplastic, black, 94V-0 rated

Contacts—Copper alloy; duplex plated .000030 [0.00076] gold in mating area, .000150 [0.00381] tin-lead on solder tail, with entire contact underplated .000050 [0.00127] nickel

Holddown—Copper alloy; plated .000150 [0.00381] tin-lead over .000050 [0.00127] nickel

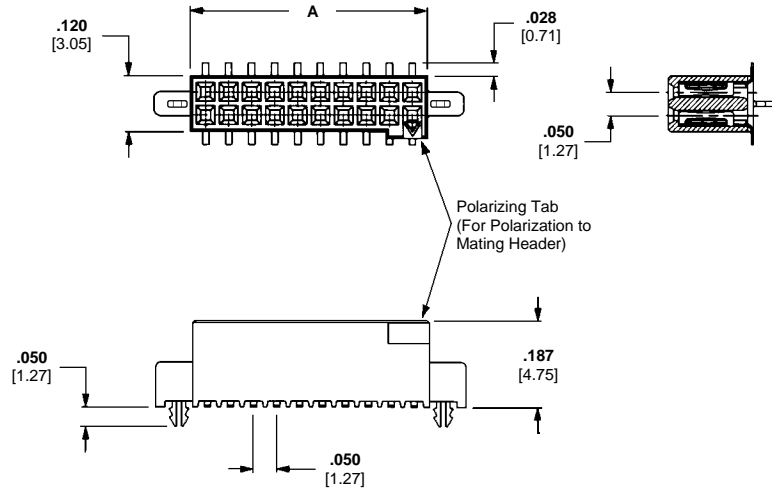

Related Product Data:

Mating Headers — pages 14, 17

PC Board Layouts — page 15

Performance Specifications — page 22

Technical Documents (page 22):

Product Specification 108-1332

Application Specification 114-7010

Packaging: Tube or Tape and Reel

No. of Pos.	Dimension A	Receptacle Part Numbers		
		Tube	Tape and Reel*	No Hold Down w/Vacuum Cover
10	.266 [6.75]	104652-1	147384-1	147413-1
20	.516 [13.11]	104652-2	147384-2	147413-3
30	.766 [19.46]	104652-3	147384-3	147413-4
40	1.016 [25.81]	104652-4	147384-4	—
50	1.266 [32.16]	104652-5	147384-5	147413-2
60	1.516 [38.51]	104652-6	147384-6	—
70	1.766 [44.86]	104652-7	147384-7	—
80	2.016 [51.21]	104652-8	147384-8	—
100	2.516 [63.91]	1-104652-0	147384-9	—

* Parts packaged in tape and reel have vacuum pick and place cover. See PC Board Layout on page 15.

**Board-to-Board Vertical Headers, Double Row, .050 x .050
[1.27 x 1.27] Centerline**

Vertical Headers,
Double Row

2

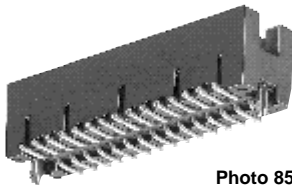

Photo 85480

For .250 [6.35] Mated Height

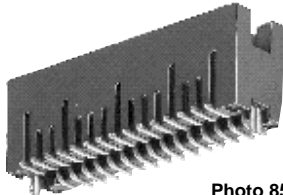

Photo 85479

For .320 [8.13] Mated Height

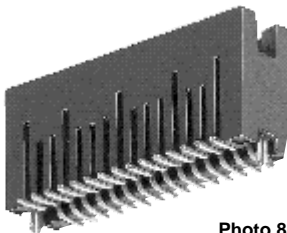
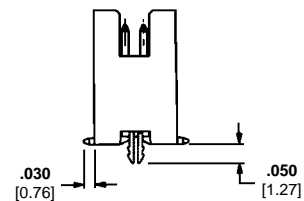
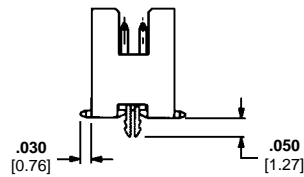
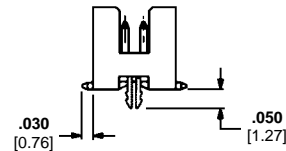
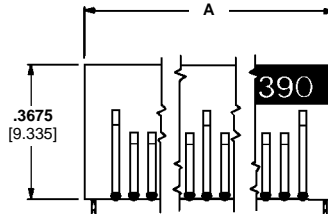
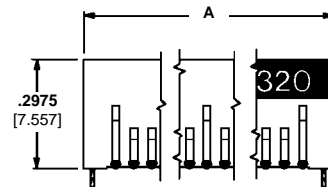
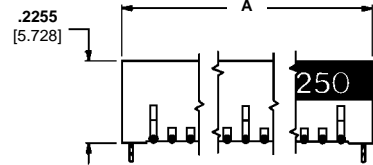
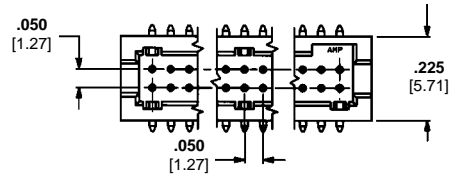

Photo 85478

For .390 [9.91] Mated Height



Material and Finish:

Housing—Glass-filled thermoplastic, black, 94V-0 rated

Contacts—Phosphor bronze; duplex plated .000030 [0.00076] gold in mating area, .000150 [0.00381] tin-lead on solder tail, with entire contact underplated .000050 [0.00127] nickel

Holddown—Copper alloy; plated .000150 [0.00381] tin-lead over .000050 [0.00127] nickel

Related Product Data:

Mating Receptacles — page 13, 19 (without latch only)

PC Board Layouts — page 15

Performance Specifications — page 22

Technical Documents (page 22):

Product Specification 108-1332

Application Specification 114-7010

Packaging: Tube or Tape and Reel

No. of Pos.	Dimension A	Header Part Numbers								
		.250 [6.35] Mated Height			.320 [8.13] Mated Height		.390 [9.91] Mated Height			
		Tubes	Tape & Reel*		Tubes	Tape & Reel*	Tubes		Tape & Reel*	
		Hold Down	No Hold Down			Hold Down	No Hold Down			
10	.372 [9.44]	104655-1	147381-1	147121-1	104656-1	147382-1	104693-1	—	147383-1	
20	.622 [15.79]	104655-3	147381-2	147121-2	104656-2	147382-2	104693-2	—	147383-2	
30	.872 [22.14]	104655-4	147381-3	—	104656-3	147382-3	104693-3	—	147383-3	
40	1.122 [28.49]	104655-5	147381-4	—	104656-4	147382-4	104693-4	—	147383-4	
50	1.372 [34.84]	104655-6	147381-5	—	104656-5	147382-5	104693-5	—	147383-5	
60	1.622 [41.19]	104655-7	147381-6	—	104656-6	147382-6	104693-6	—	147383-6	
70	1.872 [47.54]	104655-8	147381-7	—	104656-7	147382-7	104693-7	—	147383-7	
80	2.122 [53.89]	104655-9	147381-8	—	104656-8	147382-8	104693-8	—	147383-8	
90	2.372 [60.24]	—	—	—	104656-9	—	104693-9	—	—	
100	2.622 [66.59]	1-104655-1	147381-9	—	1-104656-0	147382-9	1-104693-0	147503-1	147383-9	

*Parts packaged in tape and reel have vacuum pick and place cover. See PC Board Layout on page 15.

Recommended PC Board Layouts for Vertical Connectors

Receptacles

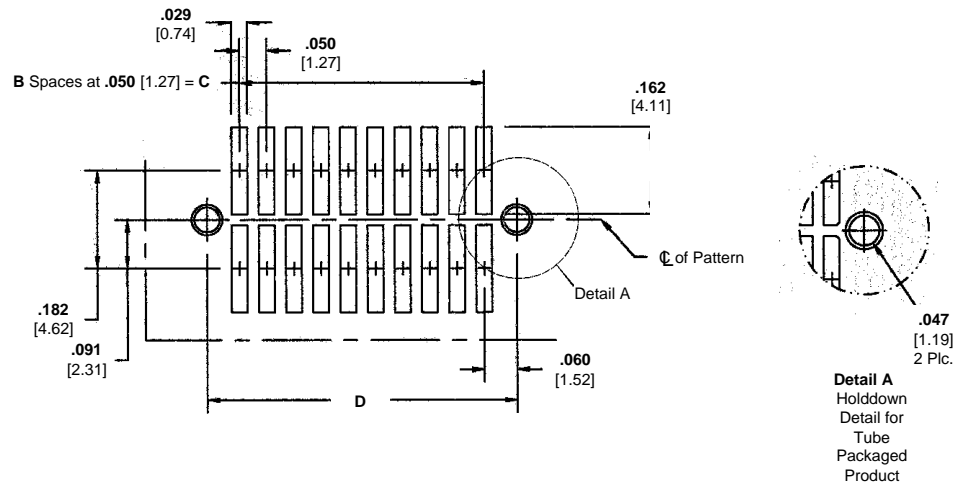

Headers

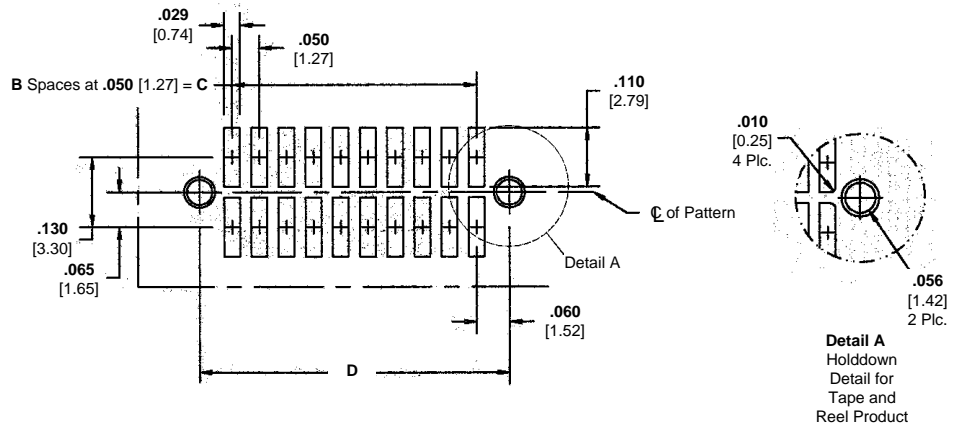

No. of Pos.	Receptacle Dimensions			Header Dimensions		
	B	C	D	B	C	D
10	4	.200 [5.08]	.320 [8.12]	4	.200 [5.08]	.322 [8.17]
20	9	.450 [11.43]	.570 [14.48]	9	.450 [11.43]	.572 [14.52]
30	14	.700 [17.78]	.820 [20.83]	14	.700 [17.78]	.822 [20.87]
40	19	.950 [24.13]	1.070 [27.19]	19	.950 [24.13]	1.072 [27.22]
50	24	1.200 [30.48]	1.320 [33.53]	24	1.200 [30.48]	1.322 [33.57]
60	29	1.450 [36.83]	1.570 [39.88]	29	1.450 [36.83]	1.572 [39.92]
70	34	1.700 [43.18]	1.820 [46.23]	34	1.700 [43.18]	1.822 [46.27]
80	39	1.950 [49.53]	2.070 [52.58]	39	1.950 [49.53]	2.072 [52.62]
90	44	2.200 [55.88]	2.320 [58.93]	44	2.200 [55.88]	2.322 [58.97]
100	49	2.450 [62.23]	2.570 [65.28]	49	2.450 [62.23]	2.572 [65.32]

Note: Refer to Tyco Electronics Customer Drawings for additional PC board layout information and dimensional tolerances.

Board-to-Board Right-Angle Headers

Product Facts

- Surface-mount products for right-angle board-to-board and cable-to-board applications
- Double-row, right-angle shrouded headers
- High density .050 x .050 [1.27 x 1.27] centerline grid
- Latching and non-latching versions available
- Non-protrusive metallic holddowns
- Metallic tabs, when soldered to PC board pad, provide added mechanical support
- Duplex plated post contacts; gold plated on mating area, tin plated on tails
- Compatible with standard surface-mount processing (VPR and IR)
- Standoffs on header housings allow for drainage of processing fluids
- All headers are polarized
- Sizes of 10, 20, 30, 40, 50, 60, 70, 80 and 100 positions
- Recognized under the Component Program of Underwriters Laboratories Inc., File No. E28476
- Certified by Canadian Standards Association File No. LR7189



AMPMODU 50/50 Grid Right-Angle Headers will accommodate a variety of high density packaging applications; right-angle board-to-board applications when mated with vertical receptacles (page 13) and right-angle cable-to-board applications when mated with cable connectors (page 19). The small .050 x .050 [1.27 x 1.27] centerline contact spacing allows efficient use of the PC board area.

Mechanical support of the headers to the PC board is provided by non-protrusive metallic holddowns designed for .062 [1.57] or thicker PC boards. These holddowns are of the same design as those used in the

vertical headers (page 14) and receptacles (page 13). There are also metallic tabs that are soldered to the surfaces of the PC board pads for added support.

AMPMODU 50/50 Grid Right-Angle Headers are available in double-row, in either latching or non-latching versions, and in sizes ranging from 10 through 100 positions (in 10 position increments). The latching version provides positive retention when mated with the latching cable connector (page 19). All headers feature polarization to help prevent misalignment during mating.

**Board-to-Board Right-Angle Headers, Double Row, .050 x .050
[1.27 x 1.27] Centerline**

Non-Latching Header

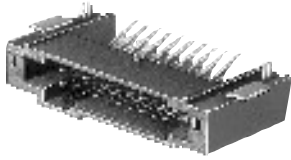

Latching Header

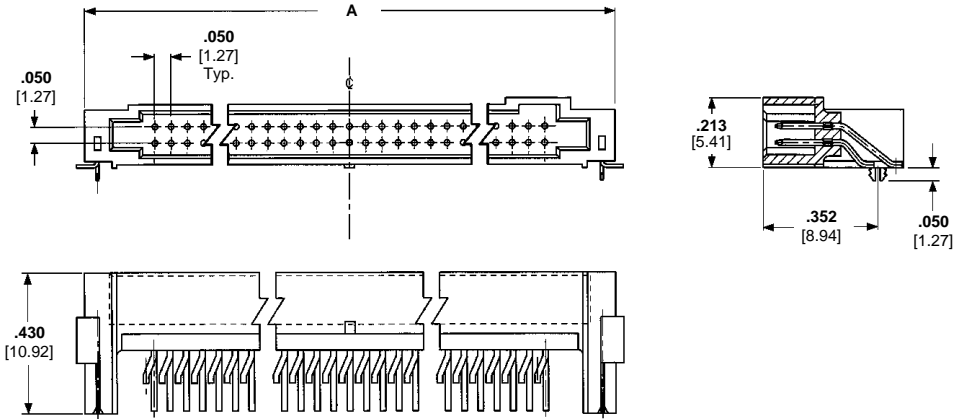

Material and Finish:

Housing — Liquid crystal polymer, black, 94V-0 rated

Contacts — Brass; duplex plated .000030 [0.00076] gold in mating area, .000150 [0.00381] tin-lead on solder tail, with entire contact underplated .000050 [0.00127] nickel

Holddown — Copper alloy; plated .0000150 [0.00381] tin-lead over .000050 [0.00127] nickel

Related Product Data:

Mating Receptacles — page 13, 19

Performance Specifications — page 22

Technical Documents (page 22):

Product Specification 108-1443

Application Specification 114-7010

Packaging: Tube

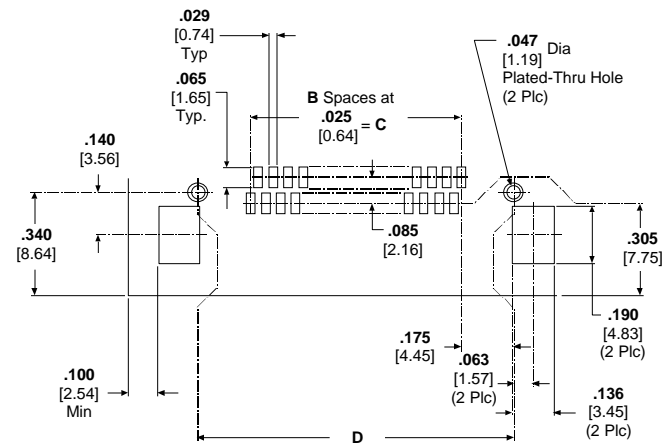



Recommended PC Board Layout

Note: Refer to Tyco Electronics Customer Drawings for additional PC board layout information and dimensional tolerances.

No. of Pos.	Dimensions				Header Part Numbers	
	A	B	C	D	Latching	Non-Latching
10	.630 [16.00]	9	.225 [5.72]	.550 [13.97]	104895-1	104894-1
20	.880 [22.35]	19	.475 [12.07]	.800 [20.32]	104895-2	104894-2
30	1.130 [28.70]	29	.725 [18.42]	1.050 [26.67]	104895-3	104894-3
40	1.380 [35.05]	39	.975 [24.77]	1.300 [33.02]	104895-4	104894-4
50	1.630 [41.40]	49	1.225 [31.12]	1.550 [39.37]	104895-5	104894-5
60	1.880 [47.75]	59	1.475 [37.47]	1.800 [45.72]	104895-6	104894-6
70	2.130 [54.10]	69	1.725 [43.82]	2.050 [52.07]	104895-7	104894-7
80	2.380 [60.45]	79	1.975 [50.17]	2.300 [58.42]	104895-8	104894-8
100	2.880 [73.15]	99	2.475 [62.87]	2.800 [71.12]	1-104895-0	1-104894-0

Cable-to-Board Connectors

Product Facts

- Double-row receptacle connectors provide cable-to-board connection capabilities for vertical headers (non-latching) and right-angle headers (latching and non-latching)
- IDC (Insulation Displacement Crimp) mass termination of solid or stranded round conductor .050 [1.27] centerline ribbon cable with PVC or polyethylene insulation
- Accommodates ribbon cable conductor sizes of 28 AWG [0.08-0.09 mm²] and 30 AWG [0.05 mm²] and insulation diameters up to .036 [0.91] maximum
- Reliable single beam receptacle contact design
- Duplex plated receptacle contacts; gold plated in mating area, bright tin-lead in termination area
- Terminating covers (sold separately) provide both strain relief and protection to the termination area
- Sizes of 10, 20, 30, 40, 50, 60, 70, 80 and 100 positions
- Connectors available with or without metal latch
- Connectors without latches are polarized to help prevent mismatching
- Recognized under the Component Program of Underwriters Laboratories Inc.,  File No. E28476
- Certified by Canadian Standards Association  File No. LR7189

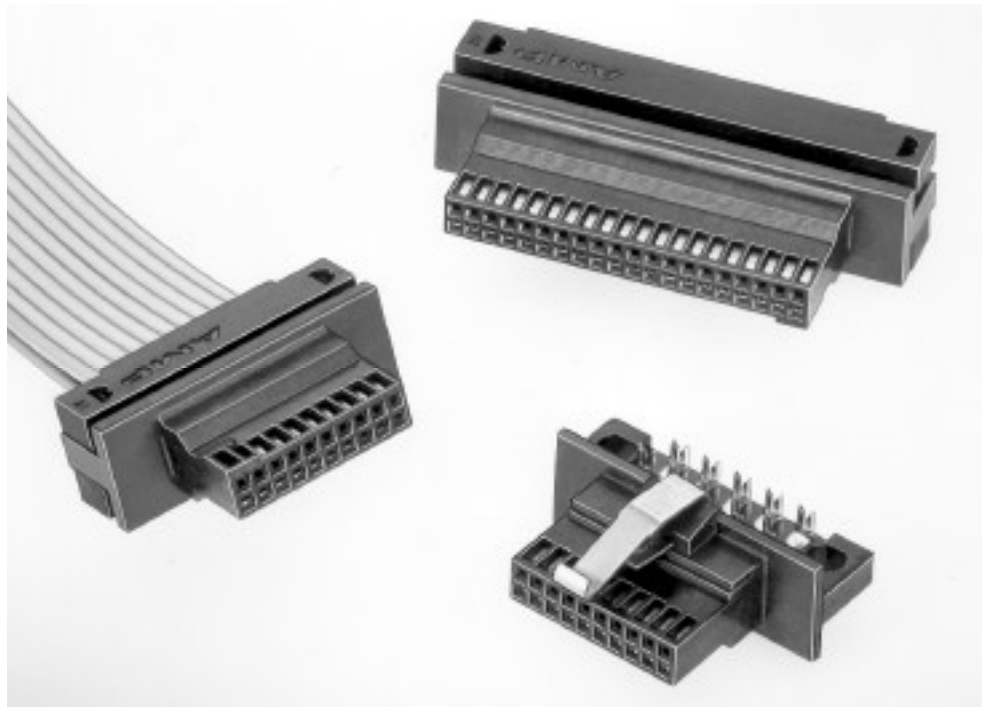

These double-row cable connectors, with a .050 x .050 [1.27 x 1.27] centerline contact spacing, provide cable-to-board connection capabilities for the AMPMODU 50/50 Grid Connector System. Cable connectors without a latch will mate with the vertical headers (page 14), while cable connectors with or without a latch can be used to mate with the right-angle headers (page 17).

The cable connectors feature reliable single-beam IDC (insulation displacement crimp) contacts which are duplex plated with .000030 [0.00076] gold. These contacts can be mass terminated to either solid or stranded round conductor

ribbon cable with conductor sizes of 28 AWG [0.08-0.09 mm²] and 30 AWG [0.05 mm²] and a maximum insulation diameter of .036 [0.91]. During termination, the terminating covers, which must be purchased separately, assist in guiding the wire into the IDC contacts, then provide strain relief when fully seated. Actual termination is accomplished with the AMP manual tooling shown on page 21.

The latching version of the cable connector is equipped with a metal latch which provides positive retention of the receptacle cable connector when mated with a surface-mounted right-angle

header. The cable connector without a metal latch features polarization to help prevent mismatching. All connectors are available in sizes ranging from 10 through 100 positions (in 10 position increments).

Cable-to-Board Receptacle Connectors, Double Row, .050 x .050
[1.27 x 1.27] Centerline (Continued)

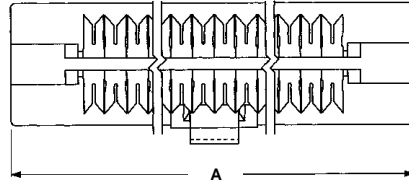
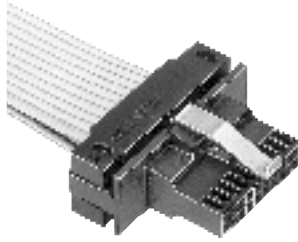

Material and Finish:

Housing — Thermoplastic, black, 94V-0 rated

Latch — Stainless steel

Contacts — Phosphor bronze; duplex plated .000030 [0.00076] minimum gold in mating area, .000050 [0.00127] minimum bright tin-lead in termination area, with entire contact underplated .000050 [0.00127] minimum nickel

Related Product Data:

Mating Headers — page 14, 17 (latching)

Terminating Covers (Must be Purchased Separately, 2 Required per Connector) — page 20

Termination Tooling — page 21

Performance Specifications — page 22

Technical Documents (page 22):

Product Specification 108-1443

Application Specification 408-9817, 408-9909

Packaging: Tube

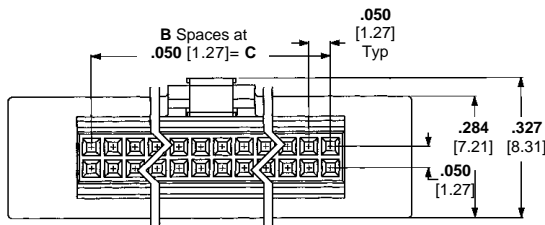
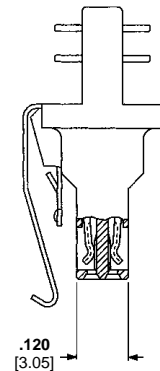
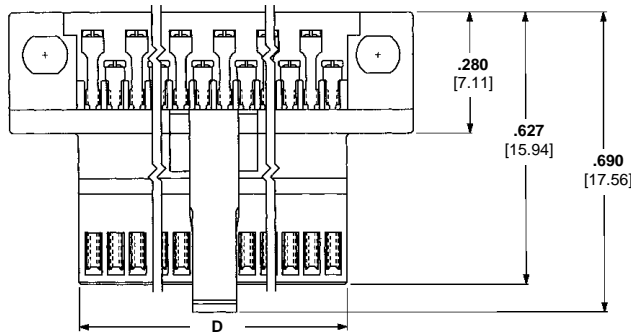

No. of Pos.	Dimensions				Receptacle Part Numbers	
	A	B	C	D	With Latch	Without Latch
10	.578 [14.68]	4	.200 [5.08]	.266 [6.76]	104892-1	104893-1
20	.828 [21.03]	9	.450 [11.43]	.516 [13.11]	104892-2	104893-2
30	1.078 [27.38]	14	.700 [17.78]	.766 [19.46]	104892-3	104893-3
40	1.328 [33.73]	19	.950 [24.13]	1.016 [25.81]	104892-4	104893-4
50	1.578 [40.08]	24	1.200 [30.48]	1.266 [32.16]	104892-5	104893-5
60	1.828 [46.43]	29	1.450 [36.83]	1.516 [38.51]	104892-6	104893-6
70	2.078 [52.78]	34	1.700 [43.18]	1.766 [44.86]	104892-7	104893-7
80	2.328 [59.13]	39	1.950 [49.53]	2.016 [51.21]	104892-8	104893-8
100	2.828 [71.83]	49	2.450 [62.23]	2.516 [63.91]	1-104892-0	1-104893-0

Terminating Covers for Cable Connectors



Material:

Glass-filled thermoplastic,
black, 94V-0 rated

Related Product Data:

Connectors used with Covers —
page 19

Termination Tooling — page 21

Technical Documents (page 22):

Product Specification 108-1443

Application Specification
408-9817, 408-9909

Packaging: Plastic bag

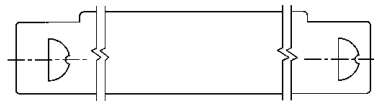
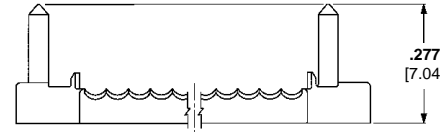
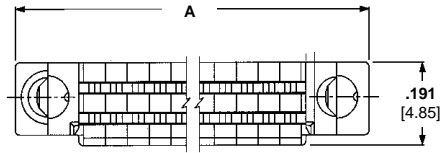

No. of Pos.	Dimension A	Terminator Cover Part Numbers
10	.565 [14.35]	104891-1
20	.815 [20.70]	104891-2
30	1.065 [27.05]	104891-3
40	1.315 [33.82]	104891-4
50	1.565 [39.75]	104891-5
60	1.815 [46.10]	104891-6
70	2.065 [52.45]	104891-7
80	2.315 [58.80]	104891-8
100	2.815 [71.50]	1-104891-0

Note: Terminating covers must be purchased separately, two are required for each cable connector.

Application Tooling for Cable Connectors

The AMP Manual Miniature Application Frame Assembly 91295-1, equipped with a Cover Closing Kit 543518-1, is used for the IDC termination of ribbon cable to the cable connectors shown on page 19.

Prior to termination, the covers must be partially assembled onto a connector housing, the cable inserted between the covers and contacts and the covers preclosed by hand, clamping the cable in place.

In the Manual Miniature Application Frame Assembly, the covers are fully seated to complete the mass termination and provide strain relief for the completed connection.

For tooling information, call Technical Support Center **1-800-522-6752**.

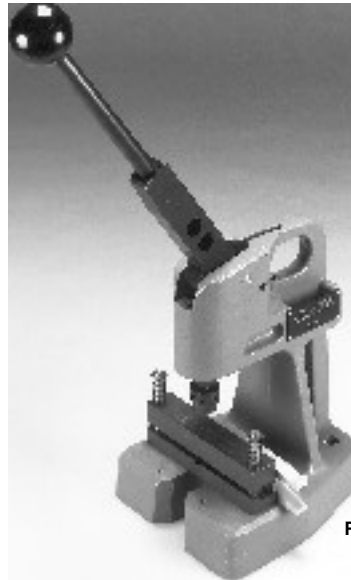

Manual Miniature Application Frame Assembly 91295-1 with Cover Closing Kit 543518-1

Note: Refer to AMP Instruction Sheets 408-9817 (Frame Assembly 91295-1) and 408-9909 (Cover Closing Kit 543518-1) for complete termination/tooling information.

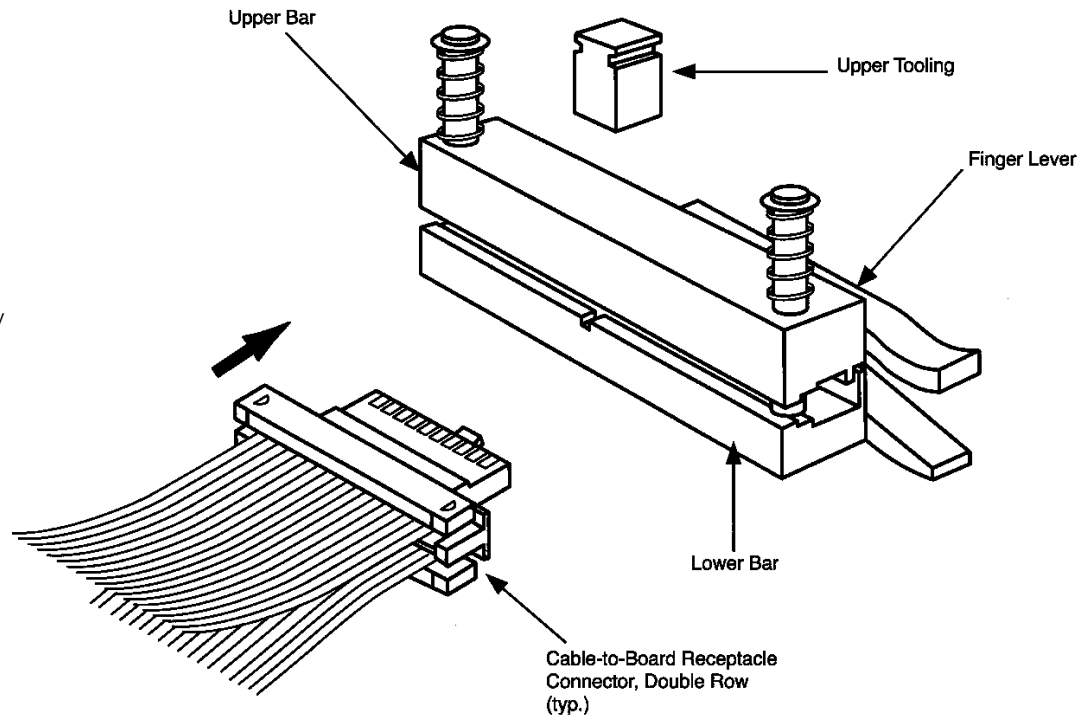

Performance Specifications

Board-to-Board Connectors, Vertical and Right-Angle**Mating Force:** 6.4 oz (1.78 N) max. per contact**Unmating Force:** 1.0 oz [0.28 N] min. per contact**Durability:** Tested to 200 cycles min.**Current Rating:** (30°C T rise): .5 ampere per contact**Operating Temperature Range:** -65°C to +105°C**Termination Resistance:** 16 milliohms max. (initial)**Insulation Resistance:** 5000 megohms min. (initial)**Dielectric Withstanding Voltage:** 300 VAC**Cable-to-Board Connectors****Mating Force:** 6.4 oz (1.78 N) max. per contact**Unmating Force Without Latch:** .5 oz [0.14 N] min. per contact**Durability:** Tested to 200 cycles min.**Current Rating:** (10°C T rise): .5 ampere per contact**Operating Temperature Range:** -65°C to +105°C**Termination Resistance:** 25 milliohms max. (initial and final)**Insulation Resistance:** 5000 megohms min. (initial)**Dielectric Withstanding Voltage:** 300 VAC

Technical Documents

Various technical documents are available for your use:

Product Specifications describe technical performance characteristics and verification tests. They are intended for the Design, Component and Quality Engineer.

108-1332 AMPMODU 50/50 Grid Vertical Board-to-Board Connectors

108-1443 AMPMODU 50/50 Grid Right-Angle Board-to-Board and Cable Connectors

Application Specifications describe requirements for using the product in its intended application and/or crimping information. They are intended for the Packaging and Design Engineer and the Machine Setup Person.

114-7010 AMPMODU 50/50 Grid Connector System

Instruction Sheets provide instructions for assembling or applying the product. They are intended for the Manufacturing Assembler or Operator.

408-9817 AMP Manual Miniature Application Frame Assembly 91295-1

408-9909 AMP Cover Closing Kit 543518-1

AMPMODU System 50 Connectors

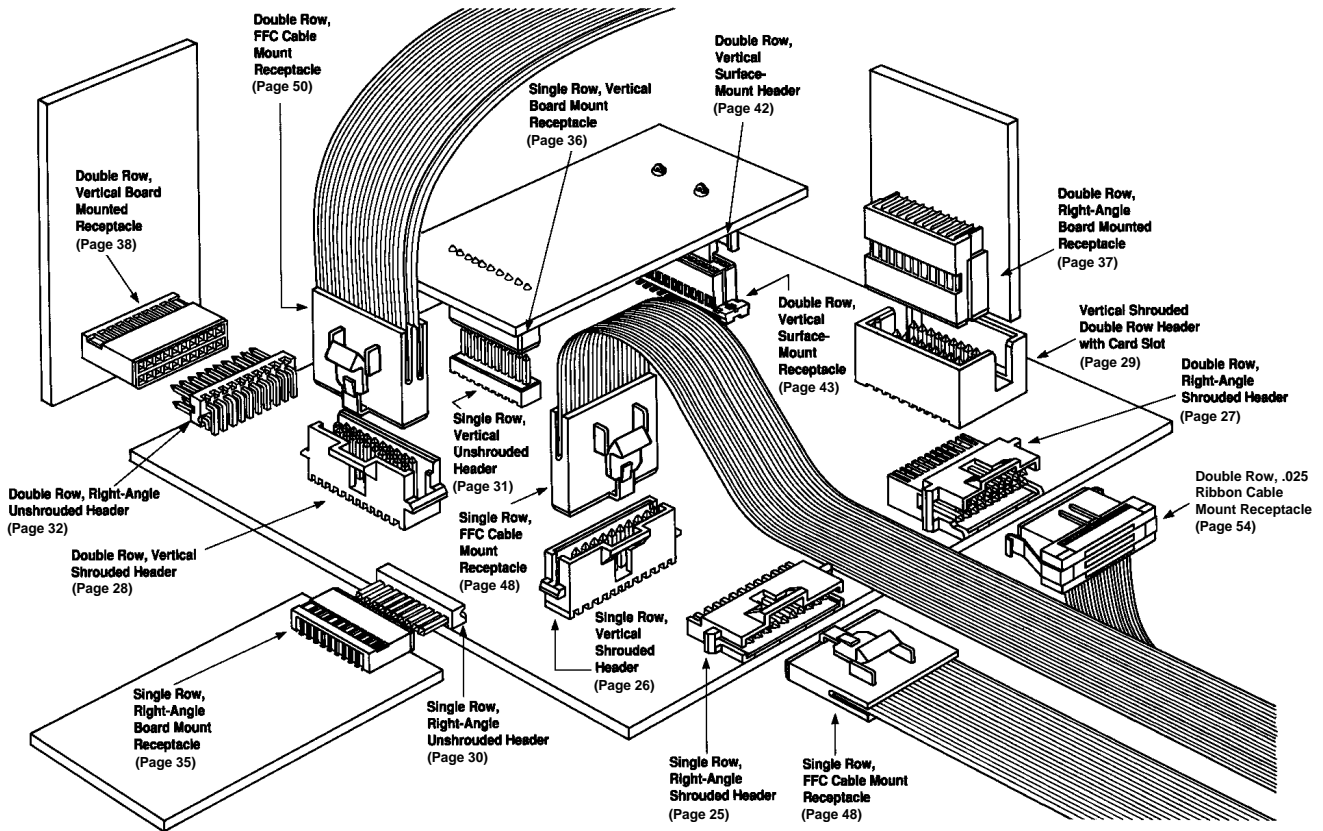

The AMPMODU System 50 connector family includes a wide variety of high density board-to-board (thru-hole and surface-mount) and cable-to-board connectors. AMPMODU System 50 is composed of one- and two-row receptacles and post headers on .050 x .100 [1.27 x 2.54] spacing between contacts for extreme density and efficient use of printed circuit board area.

AMPMODU System 50 receptacles and header assemblies can be categorized in three groups: board-mount headers, board-mount receptacles and cable-to-board receptacles. Receptacle contacts and mating .015 [0.38] square posts are formed from high conductivity copper alloy and are selectively plated with gold for higher performance and reliability.

Board-mounted thru-hole post headers and receptacle connectors are available for right-angle and vertical mating configurations. Surface-mounted connectors are available in vertical, double row styles for parallel stacking applications. Shrouded post headers provide polarization to mating cable receptacles and aid alignment of mating connectors. Unshrouded headers allow close stacking of daughter cards. Vertical stacking connectors space parallel mated boards as shown in the illustration on page 63. Housings on all board-mount assemblies are made of high temperature tolerant materials and incorporate stand-offs for free drainage of flux cleaning solutions.

Cable-to-board connectors have integral latches for positive locking to shrouded

mating headers (thru-hole or surface-mount). Ribbon cable connectors mass terminate 30 AWG [0.05 mm²] solid and 32 AWG [0.03 mm²] stranded, .025 [0.64] centerline ribbon cable with PVC or TEFLON insulation.

Connectors for mass termination to FFC cable or flexible etched circuitry have dual beam contacts; options include shielded cable and solder tabs. Both types of cable connectors are available as component parts and as completed assemblies.

The variety of components and application possibilities, combined with small size and outstanding quality, make AMPMODU System 50 perfect for high density systems.

■ **Recognized under the Component Program of Underwriters Laboratories Inc.**
File No. E28476



■ **Certified by Canadian Standards Association*,**
File No. LR 7189



*CSA certification pending on certain products, as noted.

Dimensioning:

Dimensions are in inches and millimeters. Values in brackets are metric equivalents. Metric symbols used are:

- mm (millimeter)
- cm (centimeter)
- m (meter)
- mm² (square millimeter)
- C (Celsius)
- N (newton)
- kg (kilogram)

■ **Produced under a Quality Management System certified to ISO 9001**

A copy of the certificate is available upon request.

