

THIS DRAWING IS UNPUBLISHED. RELEASED FOR PUBLICATION 20  
 © COPYRIGHT 20 TE CONNECTIVITY ALL RIGHTS RESERVED.

LOC	DIST	REVISIONS			
P	LTR	DESCRIPTION	DATE	DWN	APVD
-	-	A	RELEASED	05JUL2012	CW PY
		A1	ECR-12-015933	10SEP2012	CW PY
		A2	ECR-12-016601	18OCT2012	CW PY
		A3	ECR-13-013865	04SEP2013	LW PY

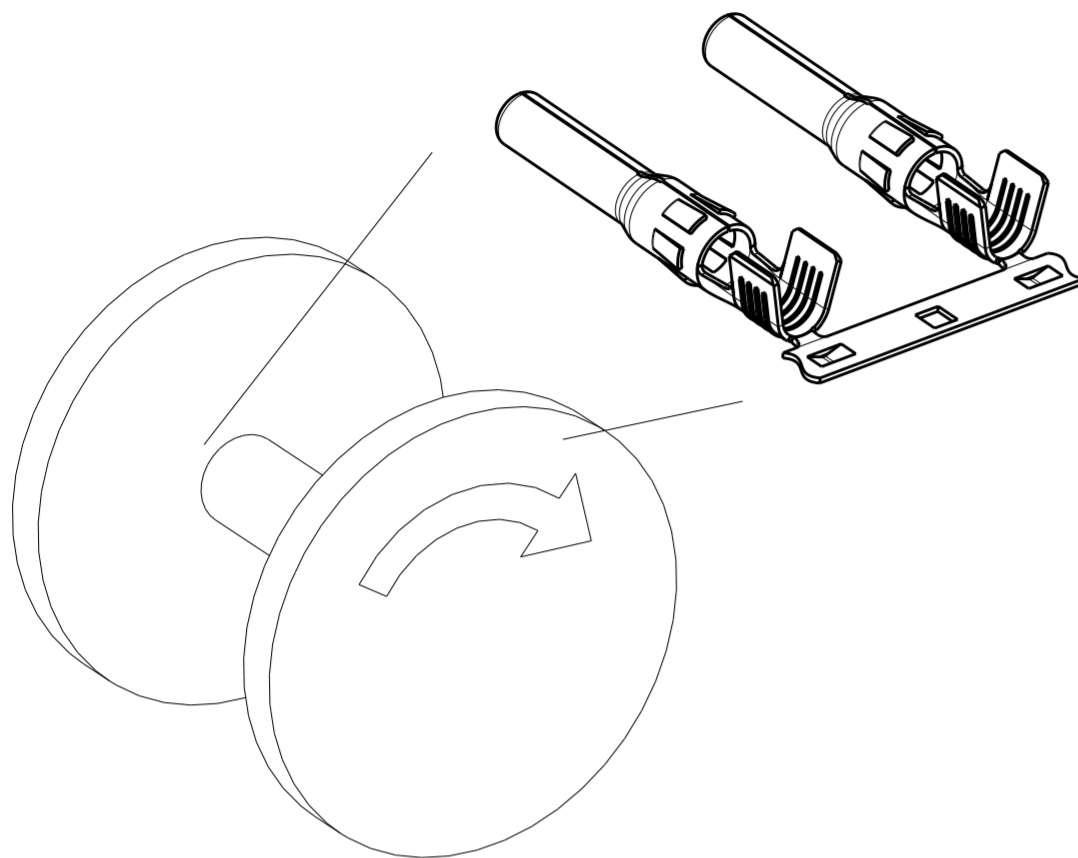

STRIP CONTACT COME OFF TO ASSEMBLY  
 2000 PCS CONTACTS MOUNTED REEL  
 REEL TYPE SUBJECT TO ALTERNATION

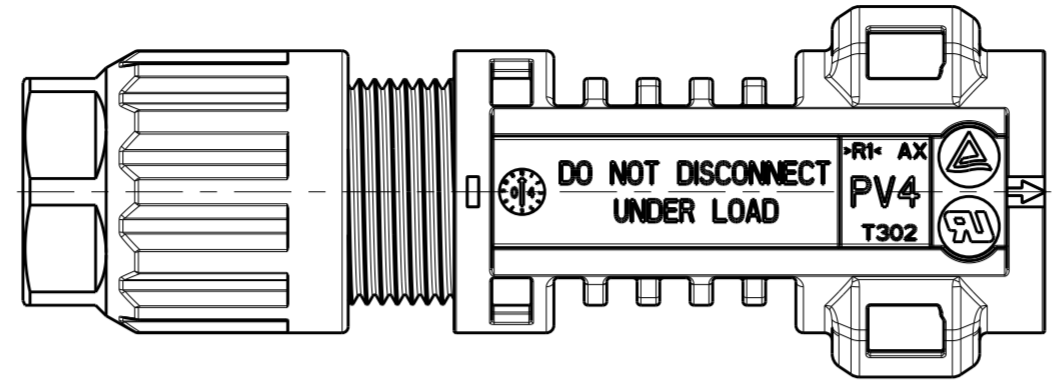

PREASSEMBLED VIEW AS SHOWN

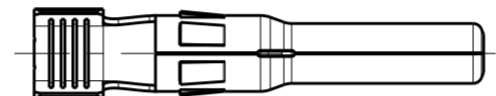

PIN CONTACT (LOOSE PIECE)

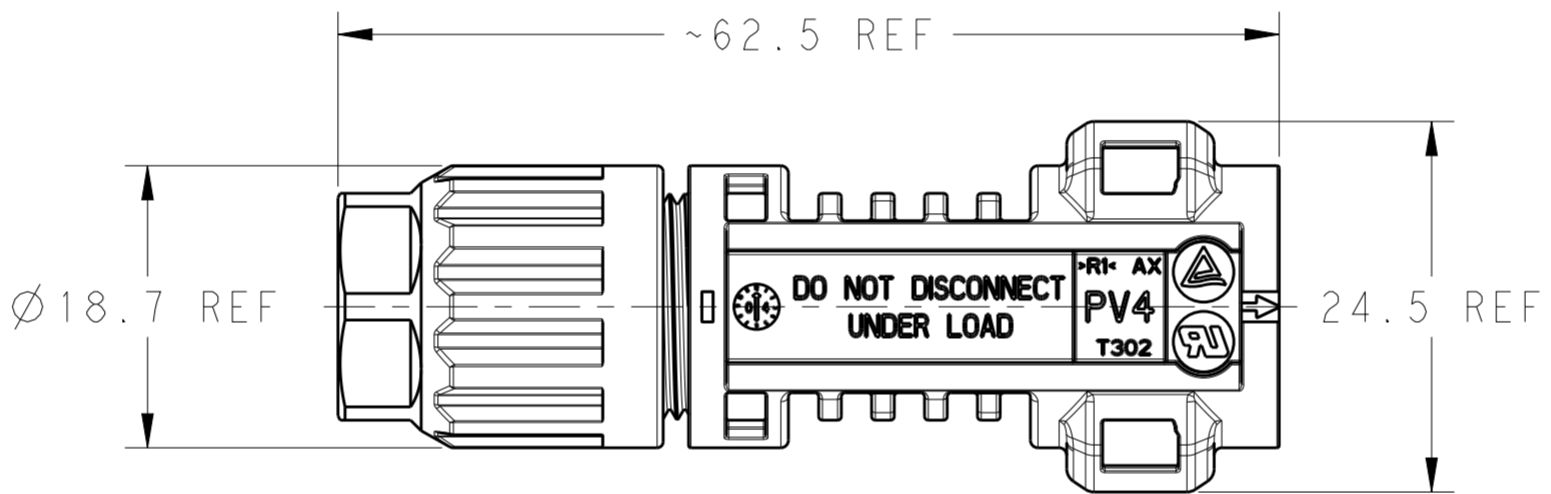

ASSEMBLED VIEW AS SHOWN

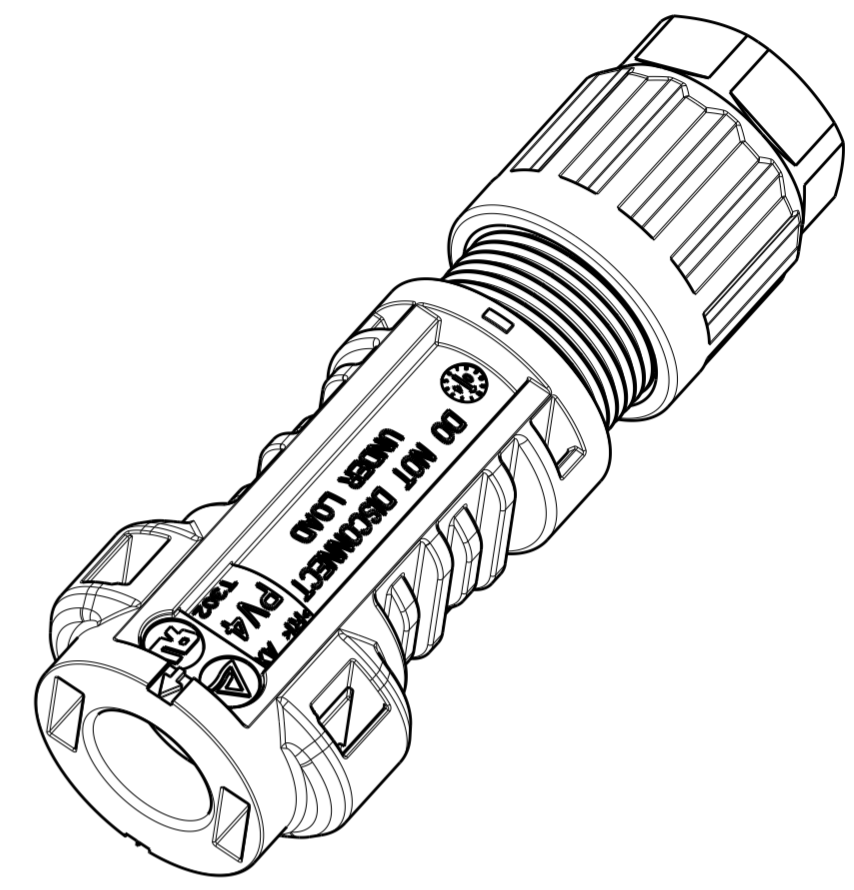

-1 AS SHOWN

1. SPECIFICATION

CABLE CONDUCTOR SIZE	4.0MM2/AWG12	6.0MM2/AWG10
RATED CURRENT (AT 85°C AMBIENT)	UL 20A DC TUV 35A DC	UL 30A DC TUV 40A DC
RATED VOLTAGE	1000V DC / TUV 1000V DC	
DEGREE OF PROTECTION, MATED	IP 68 (1m, 24h)	
AMBIENT TEMPERATURE RANGE	-40°C~+85°C	
OVERVOLTAGE CATEGORY	III	
POLLUTION DEGREE	2	
CONTACT RESISTANCE	0.5mΩ	
CONTACT MATERIAL	COPPER, TIN PLATED	
INSULATION MATERIAL	THERMOPLASTIC, UL94-V0	
SAFETY CLASS	II	
STRIP LENGTH	6.5mm	
CABLE JACKET DIAMETER	5.5~7.8mm	

CONTACT TYPE	CABLE JACKET DIAMETER (mm)	ORDER No.	PACKAGING
LOOSE PIECE	5.5~6.0	4-1971861-2	1
	6.0~7.8	4-1971861-1	
	5.5~6.0	3-1971861-2	10
	6.0~7.8	3-1971861-1	
	5.5~6.0	2-1971861-2	100
	6.0~7.8	2-1971861-1	
	5.5~6.0	1971861-2	1000
	6.0~7.8	1971861-1	
STRIP	5.5~6.0	1-1971861-2	2000
	6.0~7.8	1-1971861-1	

- 2. CONTACT SHOWN UNINSTALLED, FOR REFERENCE ONLY
- 3. USE ONLY CRIMP TOOL OF TE CONNECTIVITY TO CRIMP CONTACT. CRIMP TOOL P/N 4-1579002-2

THIS DRAWING IS A CONTROLLED DOCUMENT.

DIMENSIONS: mm	TOLERANCES UNLESS OTHERWISE SPECIFIED:	DWN: CHRIS WANG 05APR2012	TE Connectivity
	0 PLC ±	CHK: ROJAY CHEN 08MAR2012	
	1 PLC ±	APVD: PETER YIN 08MAR2012	
	2 PLC ±	NAME: PIN CONNECTOR KITS (MALE) (PV4-A*) SOLARLOK PV4 CONNECTOR	
MATERIAL	FINISH	PRODUCT SPEC: 108-106078	SIZE: A2
		APPLICATION SPEC: 114-106078	CAGE CODE: 00779
		WEIGHT: -	DRAWING NO: C-1971861
		Customer Drawing	RESTRICTED TO: -

SCALE: 2:1 SHEET 1 OF 1 REV: A3