

Table of contents

Magnetic switches – General features		Page 195
Electromechanical magnetic switches	Page 196	Electronical magnetic switches
- Selection aid cylindrical and metric housing	Page 198	- Selection aid cylindrical and rectangular housings
- Selection aid rectangular housing	Page 201	Page 205

Overview

Electromechanical magnetic switches

Cylindrical and metric housings

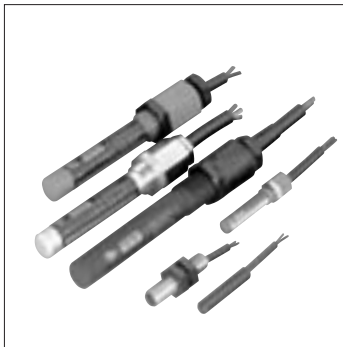

Page 199

Rectangular housings

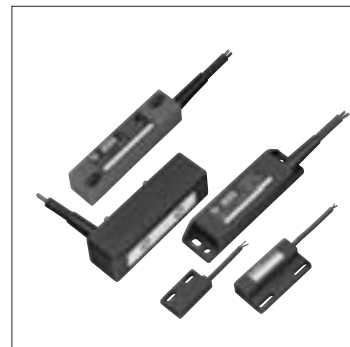

Page 202

Overview

Electronic magnetic switches

Cylindrical and metric housings



Page 206

Rectangular housings



Page 207

Magnets

Page 210

Accessories

- Overview magnets

Page 210

- Mounting brackets

Page 215

- Connecteurs

Page 215

Output diagrams

Page 203

Dimension diagrams/Magnetic switches

Page 208

Model code

Page 276

Wiring diagrams

Page 278

Magnetic switches – General features

Electromechanical and electronic models

BERNSTEIN has extended its range of electromechanical magnetic switches with electronic versions which operate according to the Hall and magnetoresistive principle.

Electromechanical and electronic magnetic switches have special properties which ensure optimal use in their respective environments.

The electronic versions are characterised by their improved mechanical characteristics (high resistance to vibration, shock or impact) and are absolutely wear-free.

The traditional electromechanical magnetic switches have a very high operational reliability thanks to the use of only one single "active" component (reed contact). The multi-voltage capability and low procurement costs allow these switches to be used in a wide range of applications.

The matrix below highlights the main features for each principle of function and helps you to decide on which magnetic switch to use for your application.



Technical features and fields of use

More detailed information about the technical features and fields of use for the two principles of function is available in the following chapters.

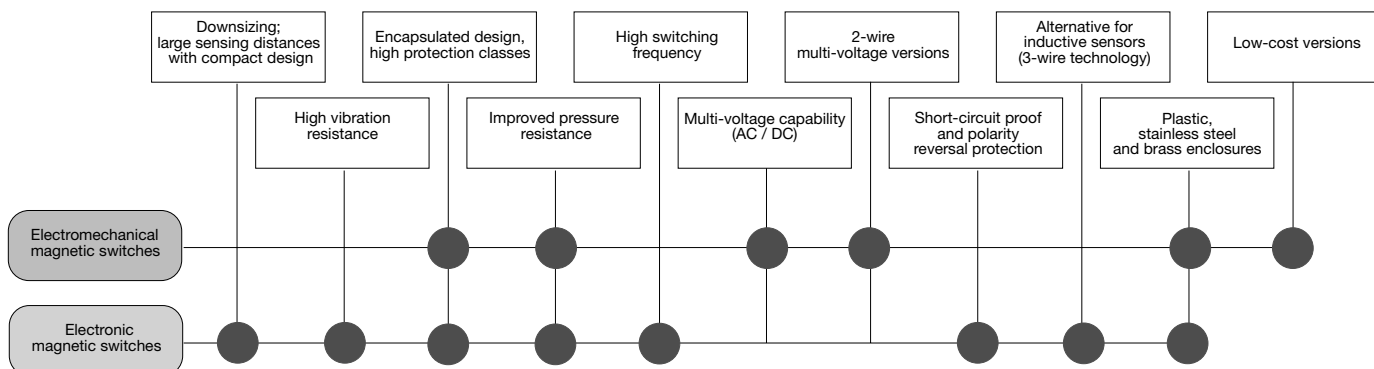

Electromechanical magnetic switches

Bernstein magnetic switches – the advantages

- reliability even under extreme ambient conditions. They are unaffected by dirt, humidity, gases, dust, etc. and operate completely free from wear and tear
- IP 67 protection
- repeatable switching point precision of approx. 0.1 mm
- may be operated from several directions
- can be mounted in any position
- electromechanical magnetic switches normally contain only a single component, thus ensuring high reliability
- easy to mount
- long electrical life (> 10⁸ switching cycle lifetime if contacts are suitably protected)
- special types available for extreme temperature ranges (- 40° C to + 150° C)
- AC/DC switching

Design, function and effect of an electromechanical magnetic switch

The basic elements of this type of switch are the components which change their behaviour when approaching a magnet. The contact paddles invert their polarity (north and south pole) under the influence of a magnetic field. The approach can be made by either permanent magnets or electromagnets; the sensitivity of the switch and the field strength of the magnet determine the sensing distance. Correspondingly the approach or moving away of the magnet controls the opening and closing of the reed contacts. Normally-closed, normally-open and changeover contacts are available in our range of products.

The magnetic switches and their auxiliary components (resistors, diodes, triacs, output stages etc.) are cast in high-quality isolating material or casting compound to increase their resistance to vibration and to guarantee the protection class up to IP 67. For use under extreme ambient conditions such as wider temperature ranges, metal versions (non-corrosive steel, aluminium and brass) as well as standard plastic versions are available.

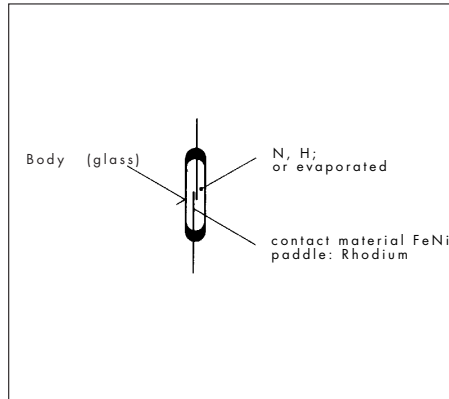

Construction of a reed contact

Biasing

Bias magnets energise or hold the bistable or normally-closed contact closed, until a stronger magnet with opposite polarity neutralises the biasing.

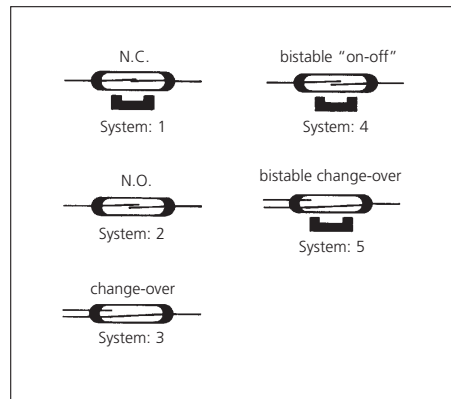

Types of reed contacts

Actuation and switching behavior

Switching behavior is principally determined by the movement and polarity of the magnet. The following drawings show typical characteristics. Body material and external dimensions are specified in the product overview. The magnetic switches with reed-contact output are identified by an „A“ in the second position of the type code (MA...).

Switching frequency

Up to 200 Hz, depending on the size of load to be switched (i. e. considerably faster than relays, contactors, etc.).

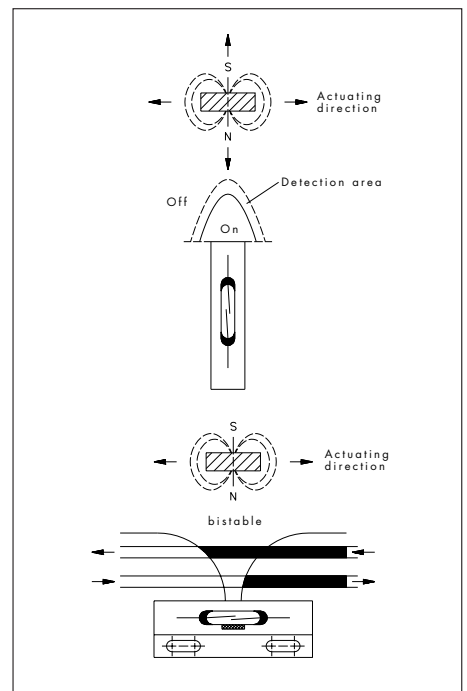
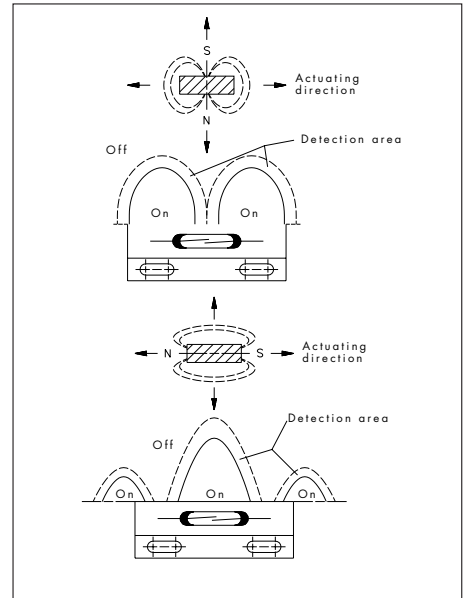

Switching distances

Refer to tables of this catalogue to identify which switching magnet may be used and therefore which minimum switching distance will be realised.

Temperature ranges

The standard version may be used in environments from -5°C to $+70^{\circ}\text{C}$. Special types are also available offering an extended operating temperature range of -40°C to $+150^{\circ}\text{C}$.

Electrical life

To maintain the long operational life of the electrical contacts, it is important to ensure the maximum supply voltage and maximum switching current are not exceeded. The following graphs show the load values for different contacts.

Guidelines for reed contact protection

The values for current, performance and voltage specified in the catalogue are valid only for resistive loads. Very often however, these loads will be used in conjunction with inductive or capacitive components when it is advisable to protect the reed contacts against voltage and current spikes. Whilst it is not possible to recommend a safe contact protection that applies to all load ranges (each individual case will require its own evaluation) we would like to present a general introduction to how reed contacts may be connected to different loads for improved operation.

1. Inductive loads

In DC voltage applications, contact protection is realised relatively easily with the help of a reverse polarity diode connected in parallel to the load. The diode polarity is selected so that it will block the normal operating voltage applied but will short-circuit any reverse voltage resulting from the switch being opened. (Note: these reverse voltage peaks can significantly exceed the normal operating voltage.)

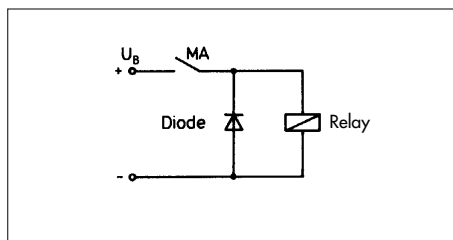

Suppression of reverse voltage peaks with a reverse polarity diode

In AC voltage applications, two solutions may be applied.

1) Voltage peaks induced by switching off inductive loads are suppressed by connecting a Voltage Dependent Resistor (VDR) in parallel to the reed contact.

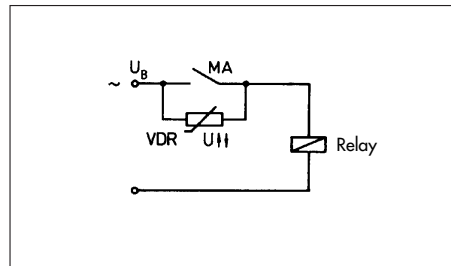

Suppression of reverse voltage peaks with a VDR

2) A Resistive/Capacitive (RC) element is connected in parallel to the contact, thus being in series with the load (vice versa is also possible).

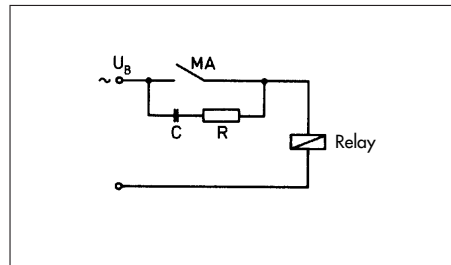

Suppression of reverse voltage peaks with RC network

2. Capacitive loads

In contrast to inductive loads, increased making currents can occur in connection with capacitive loads and lamp loads. If charged capacitors are switched (including inherent cable capacities), a sudden discharge occurs that can damage and even weld contacts closed. The intensity of this discharge depends on the capacity and length of the cable leading to the switch but may be decreased by inserting a series resistor. The size of the resistor is determined by the characteristics of the corresponding switching circuit.

It should however be as large as possible to reduce the discharge current to a permissible value to ensure reliable contact protection. These considerations are also valid for charging capacitors.

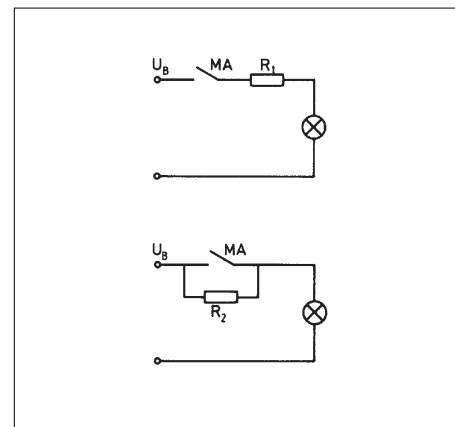
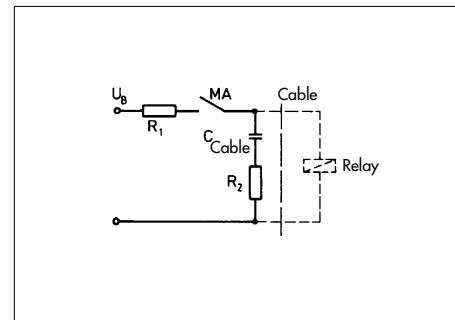

Contact protection with resistors

Using the selection matrix

To assist the user in selecting the right sensor for their application, Bernstein developed the following selection matrix. The individual fields match those in the product index to allow rapid selection of the most suitable sensor starting with the model description. By not using detailed technical descriptions the selection is considerably simplified. The corresponding output diagrams are shown on page 223.



Selection guide electromechanical magnetic switches in threaded and smooth barrels



Model	Switching capacity $S/I_{max.}$	Switching voltage $U_{max.}$	Switching distance S_{an}	Output	Housing material	Connection
MA-30 ø 6 x 28 mm	10 VA/0.5 A	250 V	19 mm	N.O.	plastic PA 6.6	cable
	5 VA/0.25 A	100 V	19 mm	change over		
MA-46 ø 6.5 x 40 mm	20 VA/0.5 A	250 V	18 mm	N.O.	plastic PA 6	cable
	20 VA/1 A	150 V	on request	change over		
MA-06 ø 12 x 86 mm	100 VA/3 A	250 V	7 mm	N.O.	aluminium	cable
	60 VA/1 A		10 mm	change over		
	250 VA/5 A		18 mm	bistable		
MA-16 ø 12 x 86 mm	100 VA/3 A	250 V	7 mm	N.O.	stainless steel	cable
	60 VA/1 A		12 mm	change over		
MA-26 ø 12 x 92 mm	100 VA/3 A	250 V	7 mm	N.O.	plastic PA 6	cable
	60 VA/1 A		12 mm	change over		
MA-36 ø 13 x 108 mm	250 VA/5 A	250 V	13 mm	bistable	plastic PA 6.6	cable
MA-04 ø 15.5 x 145 mm	80 VA/1 A	250 V	6 mm	change over	plastic PC	plug
MA-08 M 8 x 1 x 32 mm (Cable) M 8 x 1 x 40 mm (Plug)	10 VA/3 A	250 V	18 mm	N.O.	stainless steel	cable
	20 VA/1 A	100 V	13 mm	change over		
		30 V		plug		
MA-18 M 12 x 1 x 60 mm	10 VA/0.5 A	250 V	18 mm	N.O.	brass, nickel-plated	cable
	60 VA/1 A		12 mm	change over		
MA-28 M 12 x 1 x 60 mm	60 VA/1 A	250 V	15 mm	N.O.	plastic PA	cable
MA-23 M 12 x 1 x 80 mm	100 VA/3 A	250 V	6 mm	N.O.	brass, nickel-plated	cable
MA-33 M 12 x 1 x 80 mm	100 VA/3 A	250 V	7 mm	N.O.	plastic PA 6	cable
	60 VA/1 A		10 mm	change over		
	250 VA/5 A		22 mm	bistable		
MA-17 Pg 9 x 60 mm	30 VA/0.5 A	250 V	12 mm	change over	plastic PA 6	cable
MA-43 Pg 9 x 80 mm	60 VA/1 A	250 V	17 mm	change over	brass, nickel-plated	cable



Overview electromechanical magnetic switches in smooth barrels

Smooth barrels	MA-30, Ø 6 x 28 mm PA 6.6		MA-46, Ø 6.5 x 39 mm PA 6		MA-06, Ø 12 x 86 mm Al		
							
Switching distance (S _{an})	19 mm	19 mm	18 mm	on request	7 mm	10 mm	18 mm
Referring magnet (page)	T-62N/S (212)	T-62N/S (212)	T-62N/S (212)		T-62N/S (212)	T-62N/S (212)	T-62N/S (212)
Switching capacity (diagr.-no.)	10 VA (4)	5 VA (2)	20 VA (7)	20 VA (6)	100 VA (11)	60 VA (9)	250 VA (12)
Max. switching voltage	250 V	100 V	250 V	150 V	250 V	250 V	250 V
Switching function	N.O.	change over	N.O.	change over	N.O.	change over	bistable
Special features	Standard	Standard	Standard	Standard	Standard	Standard	Standard
Designation	MAK-3012-B-1	MAK-3013-X-1	MAK-4612-A-2	MAK-4613-3	MAA-0612-F-1	MAA-0613-L-1	MAA-0614-P-1
Part number	631.1230.571	631.0330.572	631.0246.500	641.0346.336	631.4206.246	631.6306.248	631.0406.554
Smooth barrels	MA-06, Ø 12 x 86 mm Al		MA-16, Ø 12 x 86 mm Stainless steel 1.4305		MA-16, Ø 12 x 86 mm Stainless steel 1.4305		
							
Switching distance (S _{an})	16 mm	10 mm	7 mm	12 mm	7 mm		
Referring magnet (page)	T-62N/S (212)	T-62N/S (212)	T-62N/S (212)	T-62N/S (212)	T-62N/S (212)		
Switching capacity (diagr.-no.)	60 VA (9)	60 VA (9)	100 VA (11)	60 VA (9)	100 VA (11)		
Max. switching voltage	250 V	250 V	250 V	250 V	250 V		
Switching function	N.O.	change over	N.O.	change over	N.O.		
Special features	Temp. range -40°C...+150°C	Temp. range -40°C...+150°C	Standard	Standard	Temp. range -40°C...+150°C		
Designation	MAA-0612-NT-4	MAA-0613-LT-1	MAN-1612-F-3	MAN-1613-L-1	MAN-1612-FT-8		
Part number	641.0206.399	631.6306.004	631.4216.476	631.6316.259	631.4216.585		
Smooth barrels	MA-26, Ø 12 x 92 mm PA 6		MA-36, Ø 13 x 108 mm PA 6.6		MA-04, Ø 15.5 x 145 mm PC		
							
Switching distance (S _{an})	7 mm	12 mm	13 mm		6 mm		
Referring magnet (page)	T-62N/S (212)	T-62N/S (212)	T-62N/S (212)		T-62N/S (212)		
Switching capacity (diagr.-no.)	100 VA (11)	60 VA (9)	250 VA (12)		80 VA (10)		
Max. switching voltage	250 V	250 V	250 V		250 V		
Switching function	N.O.	change over	bistable		change over		
Special features	Standard	Standard	Standard		plug Amphenol		
Designation	MAK-2612-F-1	MAK-2613-L-1	MAK-3614-P-2		MAK-0413-M-5		
Part number	631.4226.423	631.6326.426	631.0436.553		631.7304.313		

Overview electromechanical magnetic switches in threaded barrels

Threaded barrels	MA-08, M8 x 1 x 32 mm Stainless steel 1.4305		MA-08, M8 x 1 x 39 mm Stainless steel 1.4305		MA-18, M12 x 1 x 60 mm CuZn39Pb3	
						
Switching distance (S_{an})	18 mm	13 mm	13 mm		18 mm	12 mm
Referring magnet (page)	T-62N/S (212)	T-62N/S (212)	T-62N/S (212)		T-62N/S (212)	T-62N/S (212)
Switching capacity (diagr.-no.)	10 VA (4)	10 VA (3)	20 VA (5)		10 VA (4)	60 VA (9)
Max switching voltage	250 V	100 V	30 V		250 V	250 V
Switching function	N.O.	change over	change over		N.O.	change over
Special features	Standard	Standard	plug Ø 6.5		Standard	Standard
Designation	MAN-0812-B-1	MAN-0813-Y-1	MAN-0813-STK		MAM-1812-B-1	MAM-1813-L-1
Part number	631.1208.596	631.0308.597	631.0308.595		631.1218.294	631.6318.002



Threaded barrels	MA-28, M12 x 1 x 60 mm PA		MA-23, M12 x 1 x 80 mm CuZn39Pb3		MA-33, M12 x 1 x 80 mm PA 6		
							
Switching distance (S_{an})	15 mm		7 mm		7 mm	10 mm	22 mm
Referring magnet (page)	T-62N/S (212)		T-62N/S (212)		T-62N/S (212)	T-62N/S (212)	T-62N/S (212)
Switching capacity (diagr.-no.)	60 VA (9)		100 VA (11)		100 VA (11)	60 VA (9)	250 VA (12)
Max switching voltage	250 V		250 V		250 V	250 V	250 V
Switching function	N.O.		N.O.		N.O.	change over	bistable
Special features	Standard		Standard		Standard	Standard	Standard
Designation	MAK-2812-L-3		MAM-2312-F-1		MAK-3312-F-2	MAK-3313-L-1	MAK-3314-P-2
Part number	641.6228.260		631.4223.268		631.4233.002	631.6333.005	641.0433.350

Threaded barrels	MA-17, Pg 9 x 60 mm PA 6		MA-43, Pg 9 x 80 mm CuZn39Pb3	
				
Switching distance (S_{an})	12 mm		17 mm	
Referring magnet (page)	T-62N/S (212)		T-62N/S (212)	
Switching capacity (diagr.-no.)	30 VA (8)		60 VA (9)	
Max switching voltage	250 V		250 V	
Switching function	N.O.		change over	
Special features	Standard		Standard	
Designation	MAK-1713-K-1		MAM-4313-L-2	
Part number	631.5317.001		631.6343.544	



Selection guide electromechanical magnetic switches in rectangular housings

Model	Switching capacity $S/I_{max.}$	Switching voltage $U_{max.}$	Switching distance S_{an}	Output	Housing material	Connection
MA-11 28.6 x 6.4 x 18 mm	10 VA/0.5 A	250 V	10 mm	N.O.	plastic PA 6.6	cable
	3 VA/0.25 A	130 V	8 mm	change over		
	10 VA/0.5 A	250 V	25 mm	bistable		
MA-01 45 x 9 x 13 mm	10 VA/0.5 A	250 V	10 mm	N.O.	plastic PA 6.6	cable
MA-45 45 x 9 x 25.5 mm	10 VA/0.5 A	250 V	10 mm	N.O.	plastic PA 6.6	cable
	60 VA/1 A		5 mm	change over		
MA-13 68 x 30 x 15 mm	10 VA/0.5 A	250 V	18 mm	N.O.	plastic PC	cable
	60 VA/1 A		12 mm	change over		
MA-02 80 x 15 x 20 mm	100 VA/3 A	250 V	21 mm	N.O.	plastic PA 6	cable
	30 VA/0.5 A		18 mm	change over		
	250 VA/5 A		20 mm	bistable		
MA-12 80 x 15 x 20 mm	100 VA/3 A	250 V	21 mm	N.O.	plastic PA 6.6	cable
	60 VA/1 A		24 mm	change over		
			25 mm	bistable		
MA-44 80 x 15 x 30 mm	100 VA/3 A	250 V	19 mm	N.O.	plastic PA 6.6	plug
	80 VA/1 A		22 mm	change over		
	250 VA/5 A		20 mm	bistable		
MA-32 85 x 24 x 26 mm	250 VA/5 A	250 V	16 mm	bistable	plastic PBT	cable plug
MA-42 88 x 13 x 25 mm	100 VA/3 A	250 V	25 mm	N.O.	plastic PA 6.6	cable
	80 VA/1 A		28 mm	change over		
	250 VA/5 A		20 mm	bistable		
MA-03 105 x 25.5 x 58 mm	100 VA/3 A	250 V	10 mm	N.O.	aluminium die casting	screw termination
	80 VA/1 A		10 mm	change over		
	250 VA/5 A		15 mm	bistable		

Overview electromechanical magnetic switches in rectangular housings

Rectangular housings	MA-11, 28.6 x 6.4 x 18 mm PA 6.6			MA-01, 45 x 9 x 13 mm PA 6.6			MA-45, 45 x 9 x 25.5 mm PA 6.6	
								
Switching distance (S_{an})	10 mm	8 mm	25 mm	10 mm			10 mm	5 mm
Referring magnet (page)	TK-11-11 (229)	TK-11-11 (229)	T-67N/S	TK-11-01 (229)			TK-45 (229)	TK-45 (229)
Switching capacity (diagr.-no.)	10 VA (4)	3 VA (1)	10 VA (4)	10 VA (4)			10 VA (4)	60 VA (9)
Max. switching voltage	250 V	130 V	250 V	250 V			250 V	250 V
Switching function	N.O.	change over	bistable	N.O.			N.O.	change over
Special features	Standard	Standard	Standard	Standard			Standard	Standard
Designation	MAK-1112-B-1	MAK-1113-1.5	MAK-1114-B-5	MAK-0112-B-1			MAK-4512-B-1	MAK-4513-L-1
Part number	631.1211.541	641.0311.368	631.1411.603	631.1201.288			631.1245.539	631.6345.540
Rectangular housings	MA-13, 68 x 30 x 15 mm PC			MA-02, 80 x 15 x 20 mm PA 6.6			MA-02, 80 x 15 x 20 mm GDAISi 12	
								
Switching distance (S_{an})	8 mm			21 mm	18 mm	20 mm	10 mm	30 mm
Referring magnet (page)	T-62N/S (212)			TK-21-02 (229)	TK-21-02 (229)	T-62N/S	T-62N/S (212)	T-62N/S (212)
Switching capacity (diagr.-no.)	60 VA (9)			100 VA (11)	30 VA (8)	250 VA (12)	100 VA (11)	60 VA (9)
Max. switching voltage	250 V			250 V	250 V	250 V	250 V	250 V
Switching function	N.O.			N.O.	change over	bistable	N.O.	change over
Special features	Standard			Standard	Standard	Standard	Temp. range -40°C...+150°C	Temp. range -40°C...+150°C
Designation	MAK-1313-L-1			MAK-0212-F-1	MAK-0213-K-1	MAK-0214-P-3	MAA-0212-FT-5	MAA-0213-LT-1
Part number	631.6313.004			631.4202.204	631.5302.309	641.9402.397	631.4202.522	631.6302.389
Rectangular housings	MA-12, 80 x 15 x 20 mm PA 6.6			MA-44, 80 x 15 x 30 mm PA 6.6			MA-32, 85 x 24 x 26 mm PBT	
								
Switching distance (S_{an})	21 mm	24 mm	25 mm	19 mm	22 mm	20 mm	15 mm	16 mm
Referring magnet (page)	TK-21-12 (229)	TK-21-12 (229)	T-62N/S (212)	TK-44 (229)	TK-44 (229)	T-62N/S (212)	T-67N/S	T-62N/S (212)
Switching capacity (diagr.-no.)	100 VA (11)	60 VA (9)	60 VA (9)	100 VA (11)	80 VA (10)	250 VA (12)	100 VA (11)	250 VA (12)
Max. switching voltage	250 V	250 V	250 V	250 V	250 V	250 V	250 V	250 V
Switching function	N.O.	change over	bistable	N.O.	change over	bistable	bistable	bistable
Special features	Standard	Standard	Standard	Standard	Standard	Standard	Standard	Standard
Designation	MAK-1212-F-1	MAK-1213-L-1	MAK-1214-L-2	MAK-4412-F-1	MAK-4413-M-1	MAK-4414-P-2	MAK-3214-F-3	MAK-3214-P-1
Part number	631.4212.217	631.6312.220	641.0412.143	631.4244.536	631.7344.538	631.0444.562	631.4432.609	631.0432.598

Overview electromechanical magnetic switches in rectangular housings

Rectangular housings	MA-32, 85 x 24 x 26 mm PBT			MA-42, 88 x 13 x 25 mm PA 6.6			MA-03, 100 x 29.5 x 58 mm GK-AlSi 12		
									
Switching distance (S_{an})	15 mm	16 mm		25 mm	22 mm	20 mm	10 mm	10 mm	15 mm
Referring magnet (page)	T-62N/S	T-62N/S (212)		TK-42 (213)	TK-42 (213)	T-62N/S (212)	TA-31 (214)	TA-31 (214)	T-62N/S (212)
Switching capacity (diagr.-no.)	100 VA (11)	250 VA (12)		100 VA (11)	80 VA (10)	250 VA (12)	100 VA (11)	80 VA (10)	250 VA (12)
Max. switching voltage	250 V	250 V		250 V	250 V	250 V	250 V	250 V	250 V
Switching function	bistable	bistable		N.O.	change over	bistable	N.O.	change over	bistable
Special features	plug flat plug 6.3	plug flat plug 4.8		Standard	Standard	Standard	Standard	Standard	Standard
Designation	MAK-3214-F-STK 6.3	MAK-3214-P-STK 4.8		MAK-4212-F-1	MAK-4213-M-1	MAK-4214-P-1	MAA-0312-F	MAA-0313-M	MAA-0314-P
Part number	631.4432.612	631.0432.590		631.4242.533	631.7342.535	631.0442.534	631.4203.232	631.7303.312	631.9403.532

Technical data standard versions electromechanical magnetic switches

Switching current	see output diagram
Temperature range	-5 °C...+70 °C
Protection class (IEC 529, EN 60 529)	IP 67
Repeatable accuracy	≈ ± 0.1 mm
Mech. operational life	> 3 x 10 ⁸ switching cycles

Output diagrams electromechanical magnetic switches

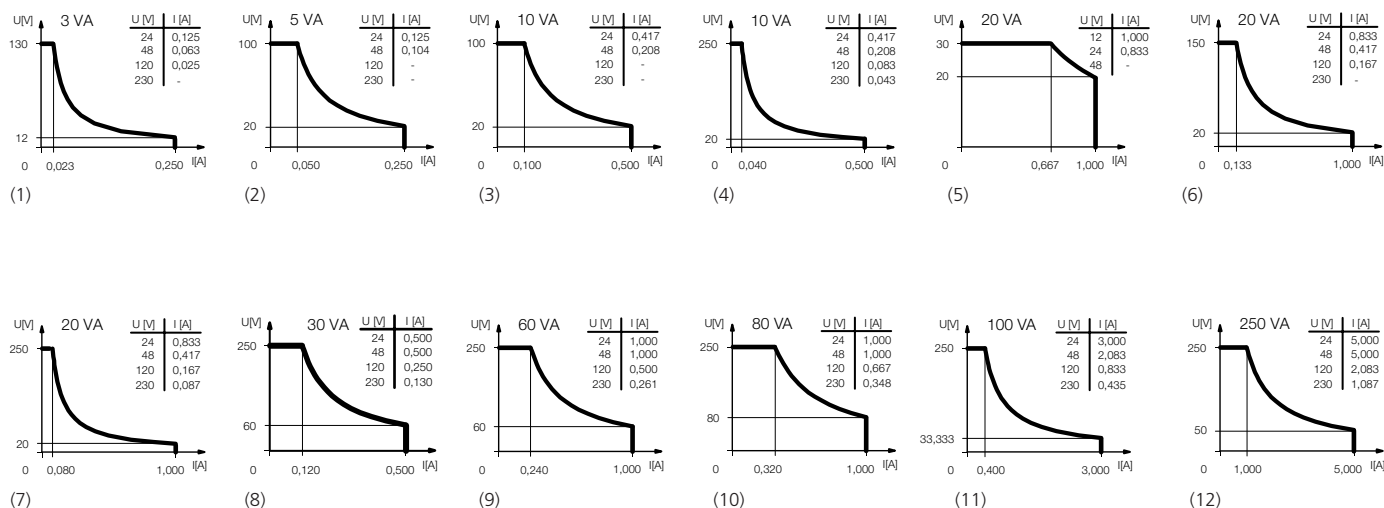

Dimension diagrams magnetic switches

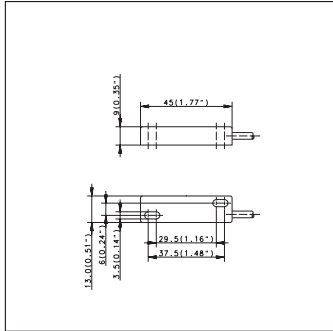

MA-01 Page 202

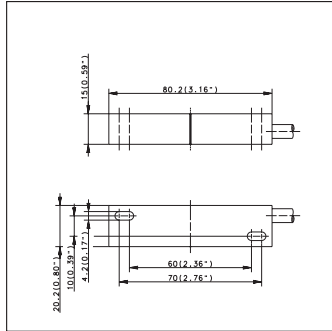

MA-02 Page 202

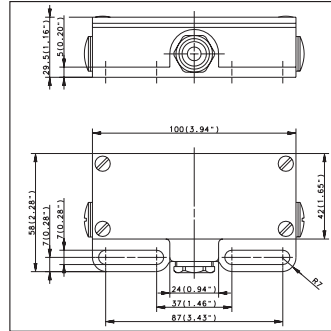

MA-03 Page 203

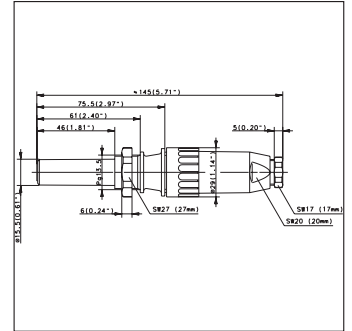

MA-04 Page 199

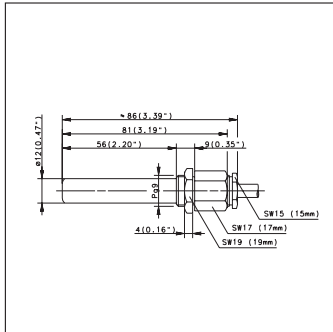

MA-06 Page 199

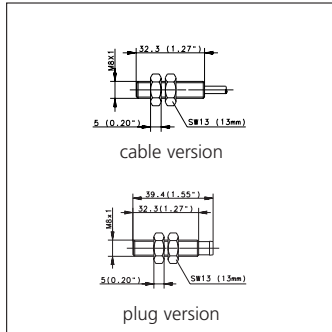

MA-08 Page 200

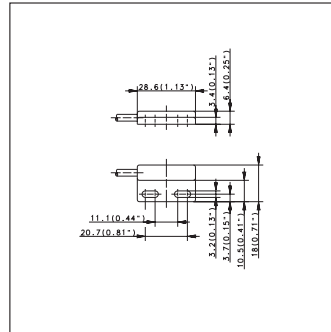

MA-11 Page 202

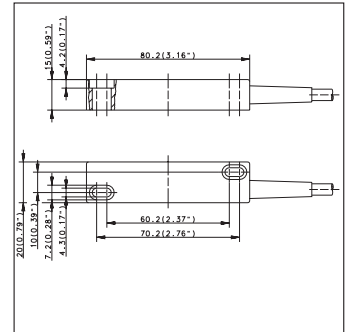

MA-12 Page 202

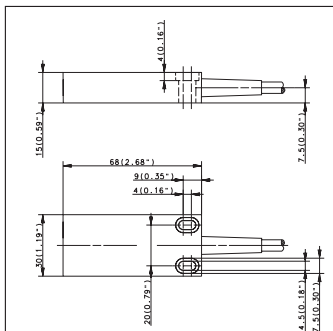

MA-13 Page 202

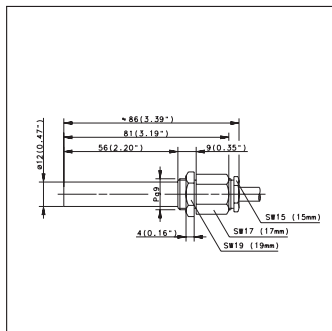

MA-16 Page 199

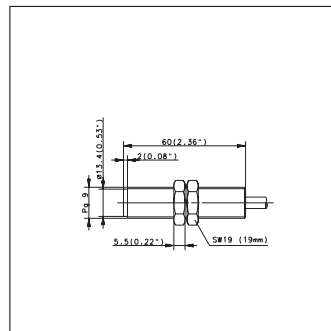

MA-17 Page 200

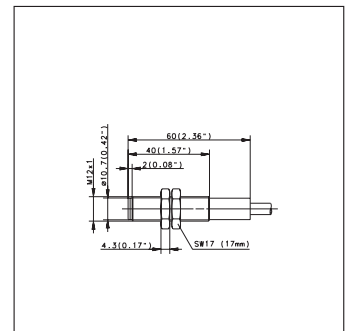

MA-18 Page 200

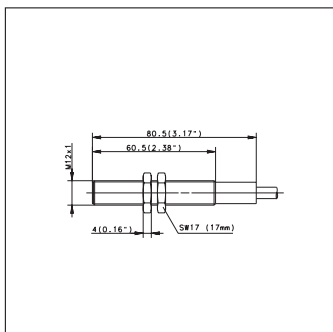

MA-23 Page 200

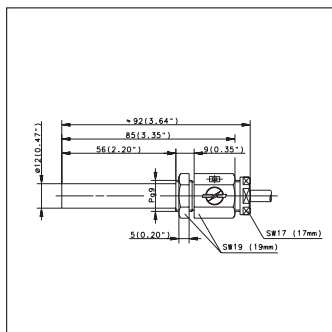

MA-26 Page 199

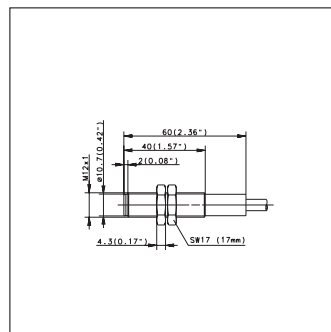

MA-28 Page 200

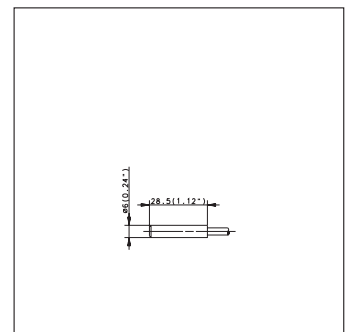

MA-30 Page 199

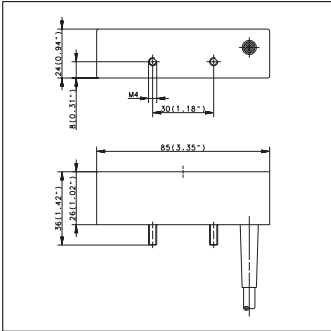

MA-32 (cable)

Page 202

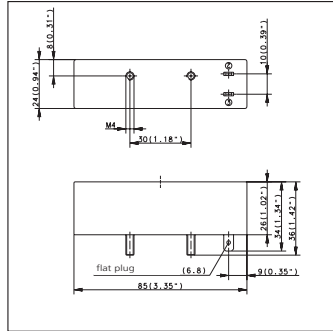

MA-32 (plug)

Page 203

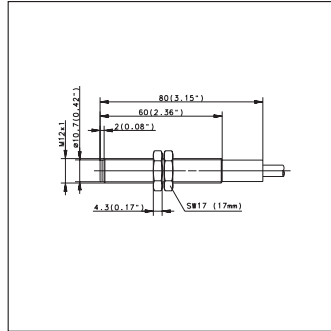

MA-33

Page 200

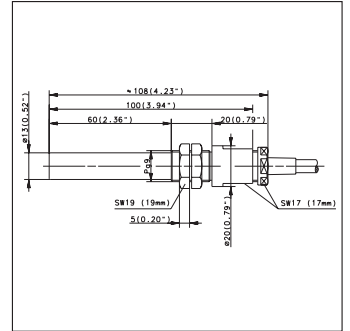

MA-36

Page 199

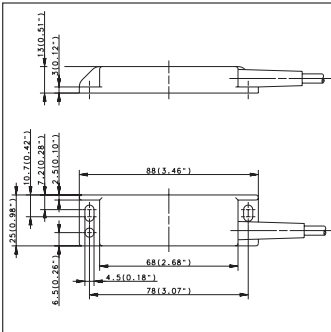

MA-42

Page 203

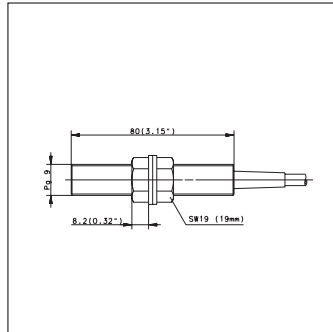

MA-43

Page 200

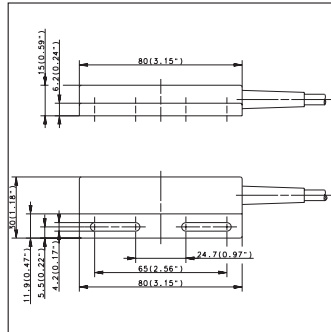

MA-44

Page 202

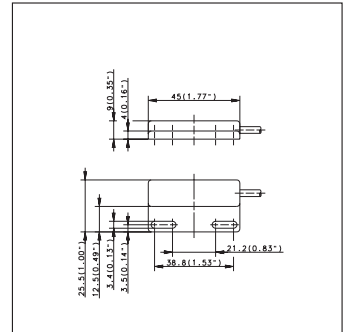

MA-45

Page 202

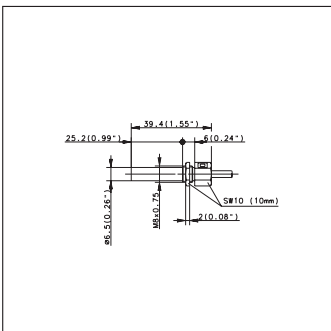

MA-46

Page 199

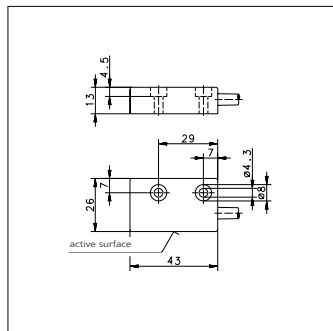

MA-52

Page 207

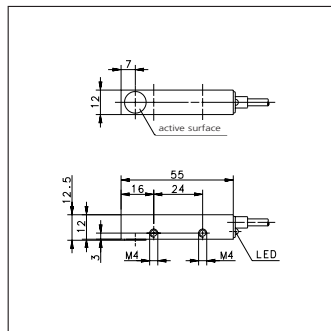

MA-55

Page 207

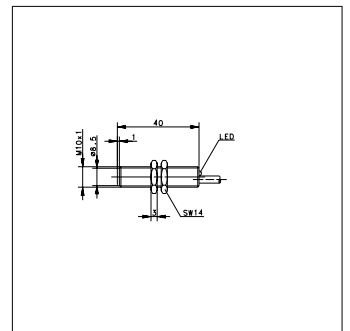

MA-61

Page 206

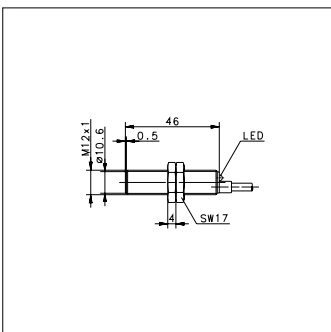

MA-62

Page 206

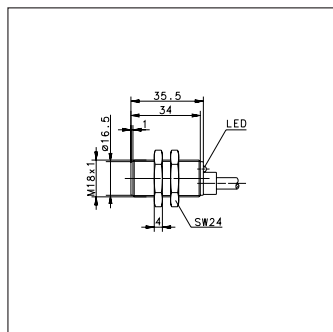

MA-63

Page 206

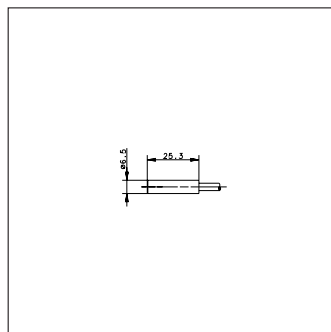

MA-70

Page 206

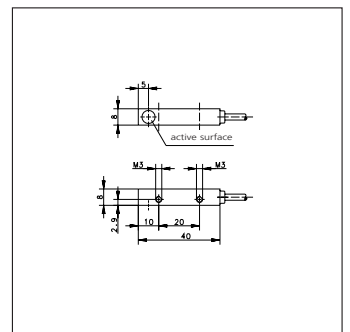

MA-80

Page 207

Magnets

1. Hard Ferrite Magnets

Barium and strontium hard ferrites are economical, reliable components that are also used in automation, control and measurement applications. If operated in higher temperature ranges, the specified switching distance will decrease by a factor of 0.2% per 1°C.

Chemical characteristics:

Ferrite magnets are oxide ceramics. They are made from approx. 80% iron oxide and 20% barium- or strontium oxide. The magnets are resistant to a large number of chemicals including solvents, dyes and weak acids. If strong organic and inorganic acids (e.g. hydrochloric, sulphuric and hydrofluoric acid) are used, their resistance is basically determined by the temperature, concentration and reaction time of the medium. In general, the resistance should first be determined using longterm tests.

Mechanical characteristics:

Due to their ceramic character, ferrites are brittle and are sensitive to shock and bending loads.



2. Rare-earth magnets

Permanent magnets that are made from samarium cobalt and neodymium iron boron are high-performance and high-quality components that are especially used in drive and control engineering.

If used in higher temperature ranges, the specified switching distance has to be decreased by a factor of 0.02% per 1°C.

Chemical characteristics:

All rare-earth magnets are metallic materials and show the corresponding characteristics associated with these materials (e.g. the polished shine immediately after being processed). The magnets will oxidise in moist surroundings and acidic environments may decompose them. Conversely, the magnets are extremely resistant to alkaline environments. In water with a pH-value of 7, rare-earth magnets will show only slight surface oxidation but otherwise are resistant.

Mechanical characteristics:

Minor chips may occur if rare-earth magnets are submitted to impact stress. They respond very sensitively to vibrations and may become demagnetised.

3. Plastic magnets

Plastic-bound permanent magnets have an interesting cost-performance ratio and can be produced in a large variety of shapes. Sprayed magnets are typical composite materials. The magnetic powder is embedded in thermoplastics (polyamides), allowing the most diverse shapes to be created.

Chemical characteristics:

Surface corrosion can rarely be found on plastic-bound magnets. For this reason, they can be used in most application fields without additional coating.

Mechanical characteristics:

Plastic magnets can be submitted at any time to bending and vibrations without breaking or chipping.

Application in explosion-hazardous surroundings

Magnets must not be handled in explosion-hazardous surroundings since they can cause sparks. Grit and chips from rare earth magnets are self-igniting and burn off with very high temperatures. They should therefore only be machined using a lot of water and never in dry conditions since even dried grinding dust can ignite.

Strong magnetic fields

Strong magnetic fields can interfere or even damage electronic or mechanical equipment. This includes cardiac pacemakers. Appropriate safety clearances are specified in the corresponding manuals or may be requested from the manufacturers.

Radioactive radiation

Permanent magnets must not be submitted to long term radioactive radiation or they may lose their magnetisation.

General stability

Rare earth magnets must be stored in dry conditions in order to avoid oxidation. They are not suitable for all environments since they are also partially soluble.

Effects on persons

There are no known side-effects caused by touching magnet materials.

Magnet shapes

Rectangular, circular and cylindrical magnets are the most common shapes of permanent magnets. In addition to these standard shapes, permanent magnets may be manufactured in many other shapes. The shape is in most cases designated during the pressing of the magnet, since any later shaping can only be performed using complex diamond tools. Holes and openings can only be inserted in line with the pressing direction.

Magnetisation direction

Magnetisation in alignment with the formed magnetic crystals is preferred since this allows the highest magnetic values to be achieved.

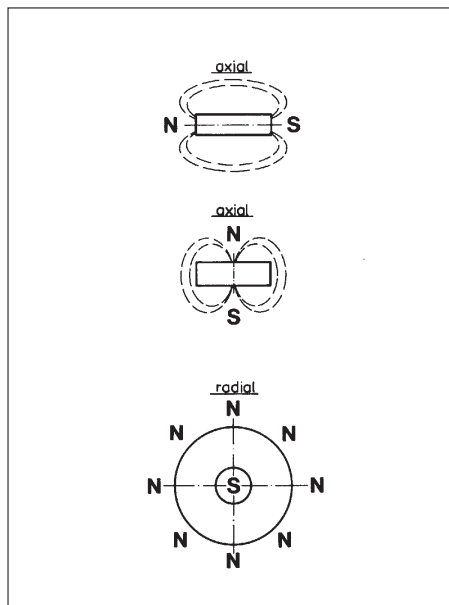

The preferred direction is achieved by submitting the magnetic powder to a strong external magnetic field (coil) during the pressing process. As magnets have no preferred direction the magnetisation direction and type can be selected freely.

Instructions for mounting a magnetic switch-system on ferromagnetic materials

If magnetic limit switches and their corresponding magnets are mounted on magnetisable material (Fe, etc.), the nominal distance may be reduced. To ensure error-free operation, a minimum gap of 15 mm between the magnetic switch and any material which can be magnetised should be maintained as a guide value. The same applies to magnets.

Applications

- counting
- position indication in lifts
- end-stop switches in pneumatic and hydraulic installations
- indication on claps, sliders and valves
- conveyors in high-bay shelving
- position detection in textile, packaging and meat-cutting machines
- run-time and down-time monitoring of machines
- control of machine tools
- level control of liquids (see page 240 ff. for more details)

Accessories

Magnets without encapsulation

Magnets without encapsulation

T-75



T-06N/S

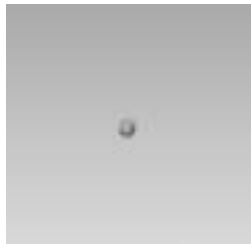

T-61N/S



T-67N/S



Magnet material	Rare-earth	Neodym-Eisen-Bor (NdFeB)	Bariumferrite	Bariumferrite
Temperature range (in relation to magnetic switch application)	-40 °C...+150 °C -40 °F...+302 °F	-40 °C...+150 °C -40 °F...+302 °F	-40 °C...+150 °C -40 °F...+302 °F	-40 °C...+150 °C -40 °F...+302 °F
Temperature coefficient	0.2 %/K	0.2 %/K	0.2 %/K	0.2 %/K
Housing material	-	-	-	-
Part number	630.1175.057	630.1106.065	630.1261.035	630.1167.054

All dimensions in mm (inch)

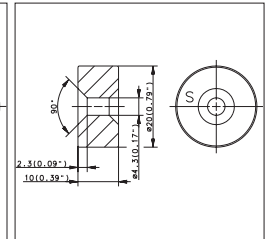
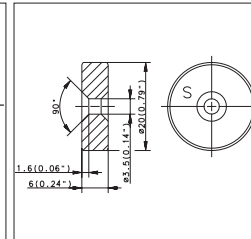
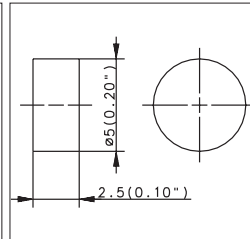
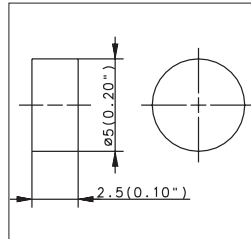

Marking:
slit on north pole side

Magnets without encapsulation

T-62N/S



T-69N/S



T-68N

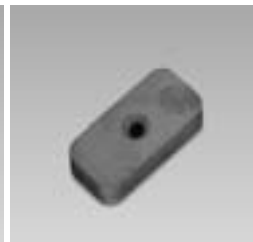

T-68S

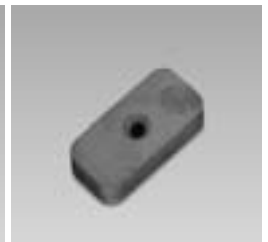

Magnet material	Bariumferrite	Bariumferrite	Bariumferrite	Bariumferrite
Temperature range (in relation to magnetic switch application)	-40 °C...+150 °C -40 °F...+302 °F	-40 °C...+150 °C -40 °F...+302 °F	-40 °C...+150 °C -40 °F...+302 °F	-40 °C...+150 °C -40 °F...+302 °F
Temperature coefficient	0.2 %/K	0.2 %/K	0.2 %/K	0.2 %/K
Housing material	-	-	-	-
Part number	630.1262.039	630.1269.031	630.1268.028	630.1368.033

All dimensions in mm (inch)

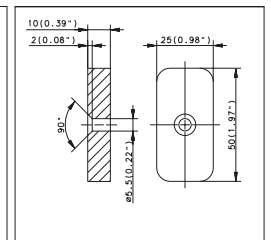
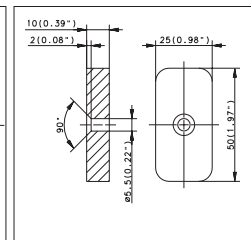
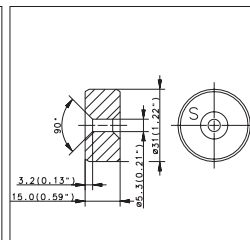
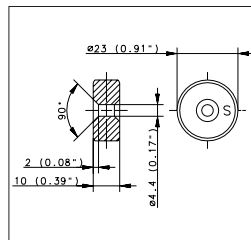

90° chamfering
on north pole side

90° chamfering
on south pole side

Accessories

Magnets in plastic housings

Magnets in plastic housings

TK-11-11



TK-11-01



TK-21-02



TK-21-12



Magnet material	AINiCo-500	AINiCo-500	AINiCo-500	AINiCo-500
Temperature range (in relation to magnetic switch application)	-20 °C...+80 °C -4 °F...+176 °F	-20 °C...+80 °C -4 °F...+176 °F	-20 °C...+80 °C -4 °F...+176 °F	-20 °C...+80 °C -4 °F...+176 °F
Temperature coefficient	0.2 %/K	0.2 %/K	0.2 %/K	0.2 %/K
Housing material	PA 6.6	PA 6.6	PA 6.6	PA 6.6
Part number	630.2111.047	630.3111.001	630.3121.002	630.2121.030

All dimensions in mm (inch)

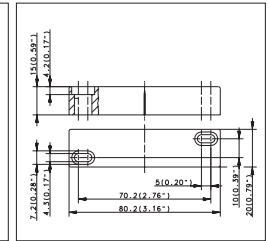
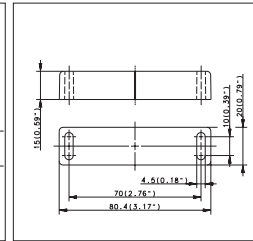
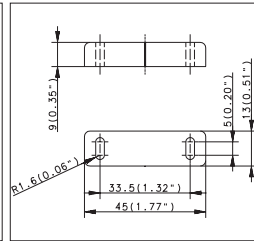
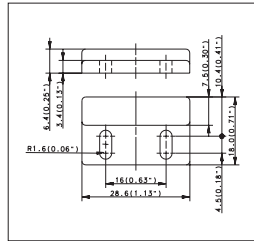

Magnets in plastic housings

TK-45



TK-42



TK-44



Magnet material	AINiCo-500	AINiCo-500	AINiCo-500	
Temperature range (in relation to magnetic switch application)	-20 °C...+80 °C -4 °F...+176 °F	-20 °C...+80 °C -4 °F...+176 °F	-20 °C...+80 °C -4 °F...+176 °F	
Temperature coefficient	0.2 %/K	0.2 %/K	0.2 %/K	
Housing material	PA 6.6	PA 6.6	PA 6.6	
Part number	630.2145.048	630.2142.049	630.2144.050	

All dimensions in mm (inch)

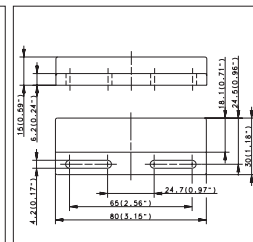
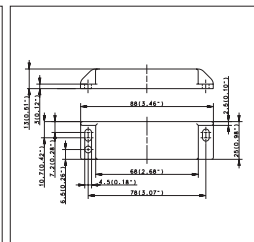
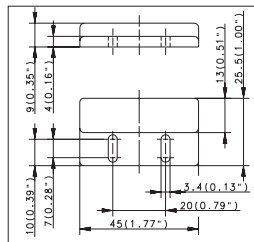

Accessories

Magnets in metal housings

Mounting brackets

Magnets in metal housings

TK-50



TK-57N

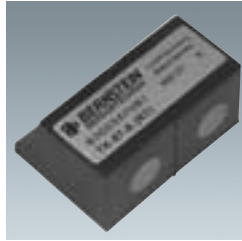

TK-57S



Magnet material	Bariumferrit	Bariumferrit	Bariumferrit
Temperature range	-20 °C...+80 °C	-20 °C...+80 °C	-20 °C...+80 °C
(in relation to magnetic switch application)	-4 °F...+176 °F	-4 °F...+176 °F	-4 °F...+176 °F
Temperature coefficient	0.2 %/K	0.2 %/K	0.2 %/K
Housing material	PA 6.6	PBT	PBT
Part number	630.2100.053	630.2257.060	630.2357.061

All dimensions in mm (inch)

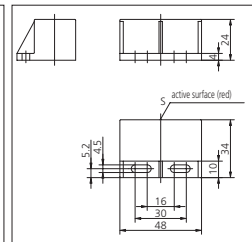
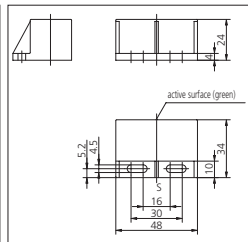
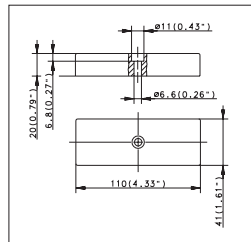

Magnets in metal housing

TA-21-02



TA-31



TA-33



Magnet material	AlNiCo-500	AlNiCo-500	Bariumferrit
Temperature range	-40 °C...+150 °C	-20 °C...+80 °C	-20 °C...+80 °C
(in relation to magnetic switch application)	-40 °F...+302 °F	-4 °F...+176 °F	-4 °F...+176 °F
Temperature coefficient	0.2 %/K	0.2 %/K	0.2 %/K
Housing material	Al	Al	Al
Part number	630.5121.064	630.3131.005	630.3133.034

All dimensions in mm (inch)

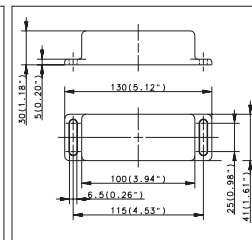
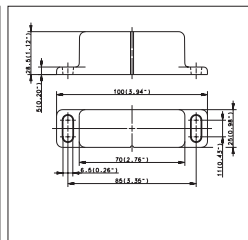
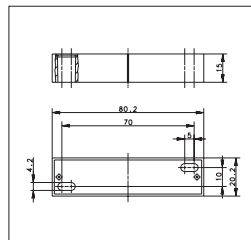

Accessories

Miniature snap-in connectors

Miniature snap-in connectors

Terminal code

- 1 = brown
- 2 = black
- 3 = blue



GDK-R06US/S00-2.5PU



GDK-R06US/S00-5PU



WDK-R06US/S00-2.5PU



WDK-R06US/S00-5PU



Material of cable sleeve	PUR	PUR	PUR	PUR
Material of coupling	PA 12	PA 12	PA 12	PA 12
Material of body	POM	POM	POM	POM
Operating voltage	60 VAC/75 VDC	60 VAC/75 VDC	60 VAC/75 VDC	60 VAC/75 VDC
Current-carrying capacity	3A	3A	3A	3A
Temperature range	-25 °C...+90 °C -13 °F...+194 °F	-25 °C...+90 °C -13 °F...+194 °F	-25 °C...+90 °C -13 °F...+194 °F	-25 °C...+90 °C -13 °F...+194 °F
Cable length	2.5 m	5 m	2.5 m	5 m
Cable structure	3 x 0.25 mm ²	3 x 0.25 mm ²	3 x 0.25 mm ²	3 x 0.25 mm ²
Protection class after installation	IP67/NEMA 4	IP67/NEMA 4	IP67/NEMA 4	IP67/NEMA 4
Part number	413.9100.219	413.9100.220	413.9100.221	413.9100.222
Dimension diagrams				

Mounting brackets

BWN-M06NI/40 x 47

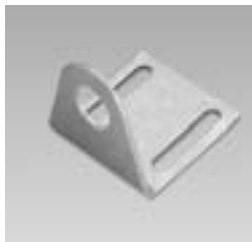

BWN-M06NI/27 x 38



BWN-M36NI



Material	Niro 1.4301	Niro 1.4301	Niro 1.4301
for models	MA-06, MA-16, MA-26, MA-15	MA-06, MA-16, MA-26, MA-15	MA-06, MA-16, MA-26, MA-15
Part number	410.2802.001	410.2802.002	490.4700.035
Dimension diagrams			