

Switches with a lever height of 5.5mm, directly mountable onto set product.

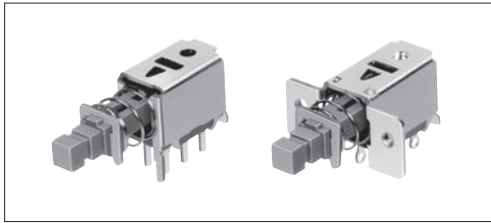

Typical Specifications

Items		Specifications
Rating (max.) / (min.) (Resistive load)		0.2A 30V DC / 50 μA 3V DC
Contact resistance (Initial / After operating life)		20mΩ max. / 40mΩ max.
Operating force		3 ± 1.5N
Operating life	Without load	10,000cycles
	With load	10,000cycles (0.2A 30V DC)

Product Line

Changeover timing	Travel (mm)	Total travel (mm)	Mounting method	Poles	Operation	Terminal type	Minimum order unit (pcs.)		Product No.	Drawing No.
							Japan	Export		
Non shorting	2.5	3.5	PC board	2	Latching	For PC board	100	3,500	SPPJ222200	1
					Momentary				SPPJ223200	
			M2-screw		Latching	For Le ad		2,500	SPPJ225800	2
					Momentary				SPPJ226400	

Note

Other varieties are also available. Please inquire.

Packing Specifications

Bulk

Product No.	Number of packages (pcs.)		Export package measurements (mm)
	1 case / Japan	1 case / export packing	
SPPJ222200 SPPJ223200	700	3,500	400 × 270 × 290
SPPJ225800 SPPJ226400	500	2,500	

Dimensions

Unit:mm

No.	Style	PC board mounting hole dimensions (Viewed from the direction A)
1	<p>For PC board</p>	

Detector

Slide

Push

Rotary

Encoders

Power

Dual-in-line
Package Type

TACT Switch™

Horizontal
Type

Vertical
Type

- Detector
- Slide
- Push**
- Rotary
- Encoders
- Power
- Dual-in-line Package Type
- TACT Switch™

- Horizontal Type**
- Vertical Type

Dimensions

Unit:mm

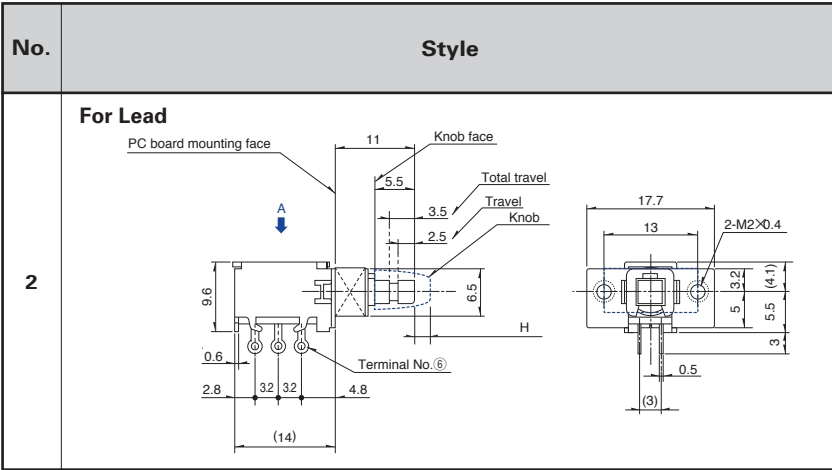

Actuator Configuration at Front Edge

Unit:mm

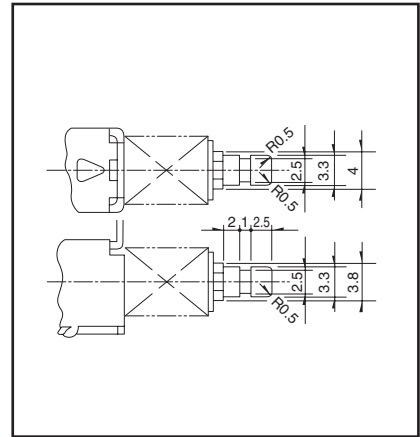

Terminal Configuration

Unit:mm

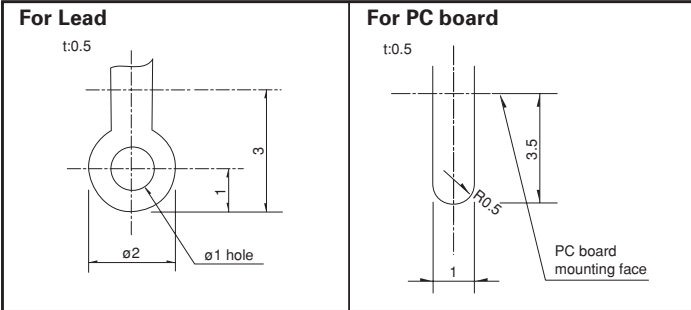

Circuit Diagram (Viewed from Direction A)

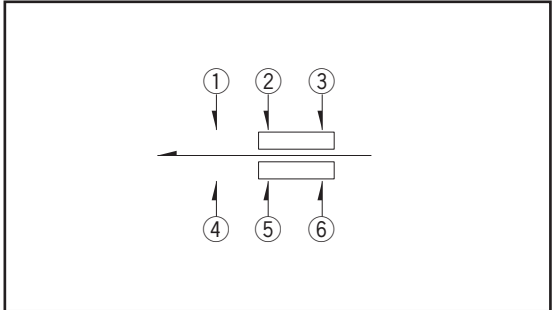

Attached Parts Please specify required knob.

Unit:mm

Knob outline drawing	Model	Knob attachment height (H)
<p>Square knob</p> <p>Color:Black</p>	UE201011	(5)
<p>Round knob</p> <p>Color:Black</p>	UE200011	(9)





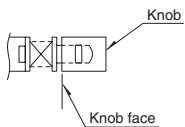













Notes

1. Other knob varieties are also available. Please inquire.
2. We recommend the use of adhesive to secure the knob when mounting onto switches.



Push Switches

List of Varieties

Series		Horizontal					Vertical				
		SPPJ3	SPPJ2	SPUJ※1	SPUP※1	SPUN	SPUN ^{medium current} ※1	SPEG	SPEJ	SPEH	
Photo											
Dimensions (mm)	W	5 or 6.6	7.2	7.5		10		7.2	7	6	
	D	12		15.2 22.7		24 36		8.39	7	6	
	H	8.3	9.6	8.8	10.3	13		3.5	5.95	5	
Travel (mm)		2.5		2	1.5 2	2.5		—	1.7	—	
Total travel (mm)		3.5		3	2.5 3	3.5		1.1	1.7	1 1.6	
Number of poles		1 2	2	2 4				1	2	1	
Operating temperature range		-40°C to +85°C		-10°C to +60°C				-40°C to +85°C		-40°C to +90°C	
Automotive use		●	●	—	—	—	—	—	●	●	
Life cycle											
Rating (max.) (Resistive load)		0.2A 30V DC		0.1A 30V DC			1A 25V DC	1mA 5V DC	0.2A 14V DC	50mA 16V DC	
Rating (min.) (Resistive load)		50μA 3V DC					1A 25V DC	50μA 3V DC	—	10μA 1V DC	
Durability	Operating life without load	10,000cycles 40mΩ max.				30,000cycles 40mΩ max.	100,000cycles 40mΩ max.	30,000cycles 500mΩ max.	10,000cycles 150mΩ max.	100,000cycles 400mΩ max.	
	Operating life with load (at max. rated load)	10,000cycles 40mΩ max.						5,000cycles 40mΩ max.	30,000cycles 500mΩ max.	10,000cycles 150mΩ max.	100,000cycles 400mΩ max.
Electrical performance	Initial contact resistance	20mΩ max.						200mΩ max.	150mΩ max.	200mΩ max.	
	Insulation resistance	100MΩ min. 500V DC						3MΩ min. 100V DC	100MΩ min. 500V DC	100MΩ min. 100V DC	
	Voltage proof	500V AC for 1minute						100V AC for 1minute	500V AC for 1minute	250V AC for 1minute	
Mechanical performance	Terminal strength	5N for 1minute						0.5N for 1minute	—	—	
	Actuator strength	Operating direction	50N	30N	50N			49N		50N	
		Pulling direction	—	—	50N			—		—	
Environmental performance	Cold	-40±2°C for 96h	-20±2°C for 96h						-40±2°C for 500h	-40±2°C for 1000h	
	Dry heat	85±2°C for 96h						85±2°C for 500h		90±2°C for 1000h	
	Damp heat	40±2°C, 90 to 95%RH for 96h						60±2°C, 90 to 95%RH for 500h		60±2°C, 90 to 95%RH for 1000h	
Page		115	117	119	120	122	122	124	125	126	

- Push Switches Soldering Conditions 137
- Push Switches Cautions 138

Notes

1. ※1. The operating temperature range for automotive applications can be raised upon request. Please contact us for details.
2. ● indicates applicability to all products in the series.

Detector

Slide

Push

Rotary

Encoders

Power

Dual-in-line
Package Type

TACT Switch™

Horizontal
Type

Vertical
Type

Push Switches Soldering Conditions

Example of Reflow Soldering Condition

1. Heating method: Double heating method with infrared heater.
2. Temperature measurement: Thermocouple 0.1 to 0.2 φ CA (K) or CC (T) at soldering portion (copper foil surface).
A heat resisting tape should be used for fixed measurement.
3. Temperature profile

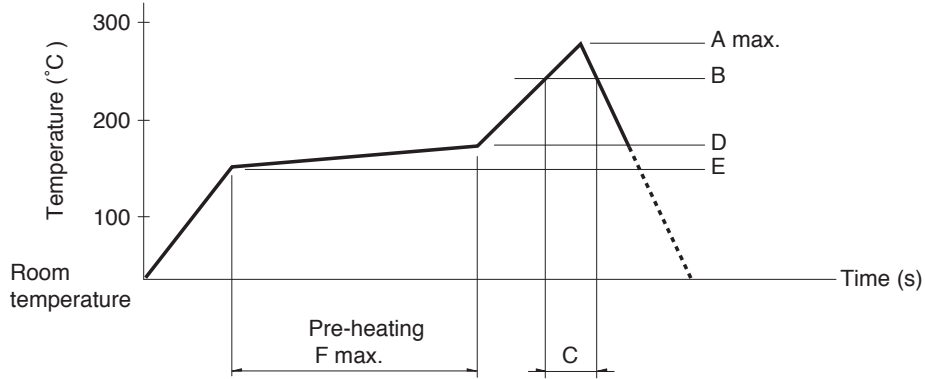

Series (Reflow type)	A (°C) 3s max.	B (°C)	C (s)	D (°C)	E (°C)	F (s)
SPEG	260	230	40	180	150	120
SPEJ						
SPEF						
SPEH						

Notes

1. The condition mentioned above is the temperature on the mounting surface of a PC board. There are cases where the PC board's temperature greatly differs from that of the switch, depending on the PC board's material, size, thickness, etc. The above-stated conditions shall also apply to switch surface temperatures.
2. Soldering conditions differ depending on reflow soldering machines. Prior verification of soldering condition is highly recommended.

Reference for Hand Soldering

Series	Soldering temperature	Soldering time
SPPJ3, SPPJ2, SPUN, SPPH4, SPPH1	350±5°C	3+1/0s
SPED2, SPED4	350±5°C	3±1s
SPEJ	350±5°C	4s max.
SPEG, SPPH2, SPEF	350±10°C	3s max.
SPEH	350°C max.	3s max.
SPUJ, SPUP	300±5°C	3+1/0s

Reference for Dip Soldering

(For PC board terminal types)

Series	Items		Dip soldering	
	Preheating temperature	Preheating time	Soldering temperature	Duration of immersion
SPPJ3	100°C max.	60s max.	260±5°C	5±1s
SPUN	100°C max.	60s max.	260±5°C	10±1s
SPUJ, SPUP, SPPH2, SPPH4	—		260±5°C	5±1s
SPPJ2, SPPH1, SPED2, SPED4, SPEF	—		260±5°C	10±1s

Detector

Slide

Push

Rotary

Encoders

Power

Dual-in-line
Package Type

TACT Switch™

Horizontal
Type

Vertical
Type