

NOTES:

- ELECTRICAL:
  - A. IMPEDANCE: 50Ω (NOMINAL)
  - B. FREQUENCY RANGE: 0-6 GHz
  - C. CONTACT RESISTANCE: CENTER: 20mΩ MAX.; MEASURED AT 10mA MAX. 25 mΩ MAX AFTER CYCLING  
OUTSIDE: 10mΩ MAX. 15 mΩ MAX AFTER CYCLING
  - D. INSULATION RESISTANCE: 500MΩ MIN.; MEASURED AT 100 VDC.
  - E. WITHSTANDIN VOLTAGE: NO LINE OR INSULATION BREAKDOWN: 200 VAC FOR 1 MIN.
  - F. V.S.W.R. : 1.3 MAX. AT DC TO 3GHz, 1.4 MAX. AT 3 TO 6GHz
  - G. TYPICAL INSERTION LOSS : .0018\*L\*√Frequency in GHz]+.087\*√Frequency in GHz]
- PHYSICAL:
  - A. FEMALE CONTACT HOLDING FORCE: 0.15N MIN. : MEASURED WITH A Ø0.475MM PIN GAUGE.
  - B. DURABILITY: 30 CYCLES
  - C. TEMPERATURE RANGE: -40°C TO +90°C.
  - D. AMC CONNECTOR MATING FORCE: 15N TYPICAL
  - E. AMC CONNECTOR DEMATING FORCE: 10N TYPICAL - 20N MAX
  - F. AMC INTERFACE IS FULLY COMPATIBLE WITH "U.FL" SERIES PRODUCT.
- MATERIALS AND FINISHES: (IN MICROMETERS)
  - CONNECTOR BODY: PHOSPHOR BRONZE, SILVER PLATED (0.76 MIN.) OVER COPPER (1 MIN)
  - CONNECTOR CENTER CONTACT: PHOSPHOR BRONZE, GOLD PLATED (0.076 MIN.) OVER NICKEL (2 MIN)
  - CONNECTOR INSULATOR: HIGH TEMP PLASTIC UL 94V-0, BLACK
  - CABLE JACKET: FEP
  - CABLE DIELECTRIC: FEP
  - CABLE CENTER CONDUCTOR: ANNEALED COPPER WIRE STRANDED, SILVER PLATED
  - CABLE OUTER CONDUCTOR: ANNEALED COPPER WIRE BRAID, TIN PLATED
- PACKAGING:
  - A. PACKAGED IN BAGS OF 100 PIECES

THIRD ANGLE PROJ.

REVISIONS

REV	DESCRIPTION	DATE	ECO	APPR
-	RELEASE TO MFG.	-----	-----	-----
E	REDRAWN, ADDED NOTE 1G,485 AND COD, ADD ORIENTAION AND COLORS	10/2/14	50005	EW
F	ADDED COLORS: ORANGE, YELLOW, BROWN	08-Jun-16	01067	JTS

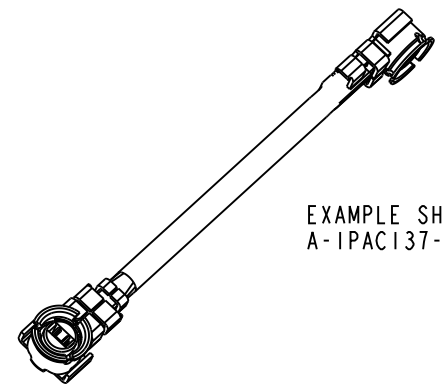

EXAMPLE SHOW :  
A-IPAC137-XXXZY

SCALE 3.000

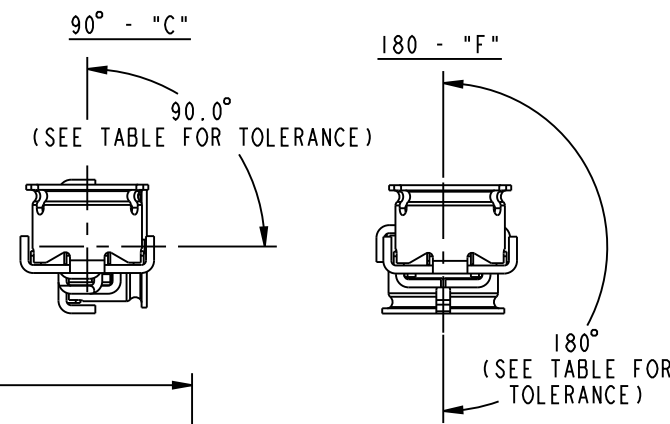

CABLE ASSEMBLY TOLERANCE		
OVERALL LENGTH L (mm)	STANDARD TOLERANCE (mm)	ORIENTATION TOLERANCE
35<L<100	± 4	±30°
100<L<200	± 4	±45°
200 < L 500	± 8	
500 < L 1000	± 12	
1000 < L	±1.5 %	

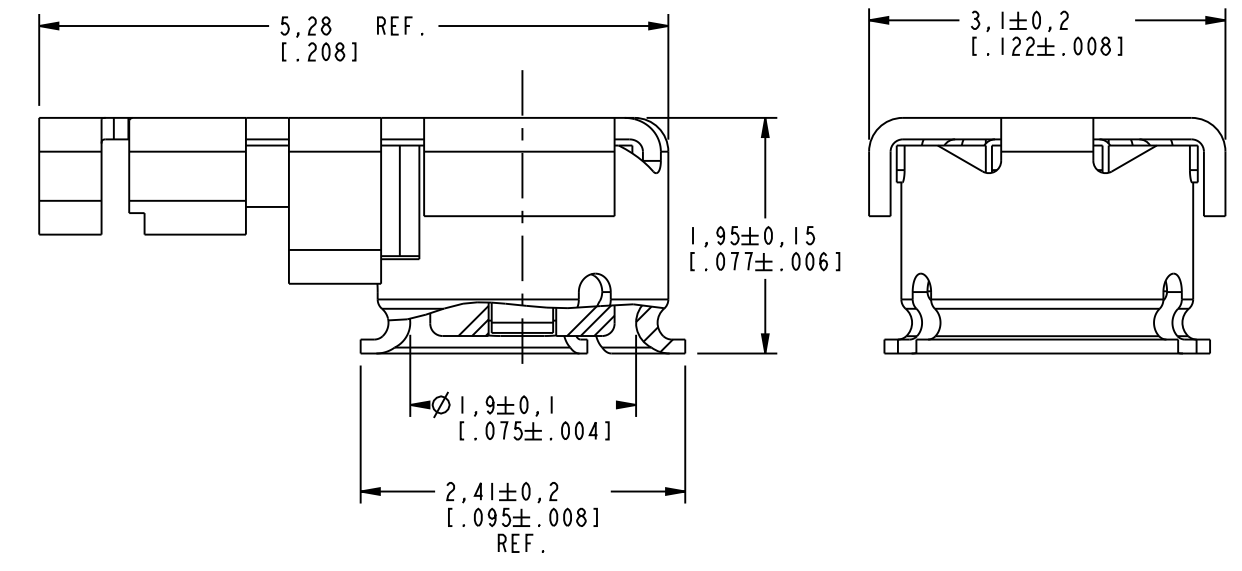
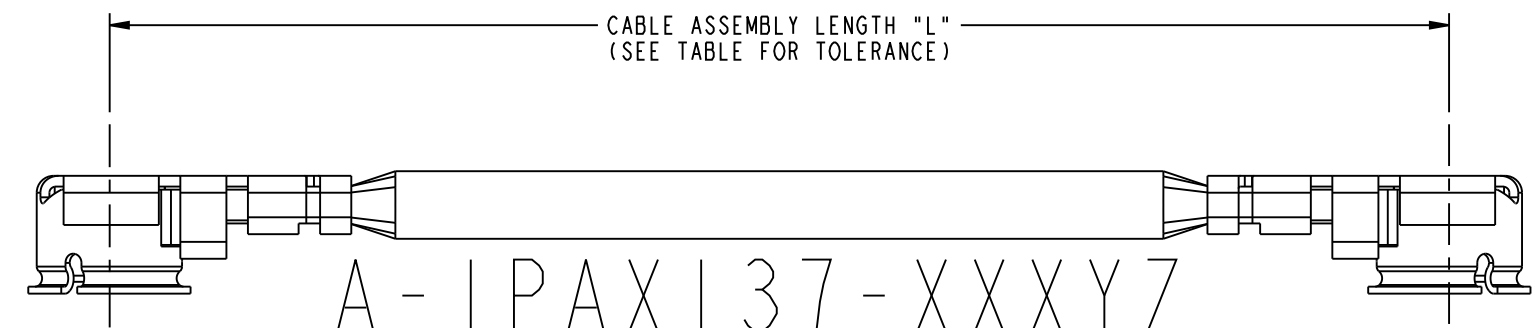

A-IPAX137-XXXZY

SERIES NAME (A=AMC) ———— AMC RIGHT ANGLE PLUG ————

ORIENTATION:  
C = 90° (CLOCKWISE)  
F = 180°  
- = 0°

NO. OF TERMINATED ENDS (1 OR 2)

CABLE COLOR:  
G=GRAY    A=ORANGE  
B=BLACK   Y=YELLOW  
W=WHITE   N=BROWN  
U=BLUE    E=GREEN  
R=RED

CABLE DIAMETER IN mm (137 = 1.37 mm)

CABLE ASSEMBLY LENGTH IN mm (SHORTEST LENGTH IS 35mm)

**CUSTOMER OUTLINE DRAWING**

ALL OTHER SHEETS ARE FOR INTERNAL USE ONLY

AMC RIGHT ANGLE PLUG

UNLESS OTHERWISE SPECIFIED, DIMENSIONS ARE IN METRIC AND TOLERANCES ARE: <0.5mm ±0.05mm    0.5 - 6mm ±0.1mm    6 - 30mm ±0.2mm    30 - 120mm ±0.3mm    ANGLES ±1° NOTICE - These drawings, specifications, or other data (1) are, and remain the property of Amphenol corp. (2) must be returned upon request; and (3) are confidential and not to be disclosed to any person other than those to whom they are given by Amphenol Corp. the furnishing of these drawings, specifications, or other data by Amphenol Corp., or to any other person to anyone for any purpose is not to be regarded by implication or otherwise in any manner licensing, granting rights to permitting such holder or any other person to manufacture, use or sell any product, process or design, patented or otherwise, that may in any way be related to or disclosed by said drawings, specifications, or other data.	MATERIAL	DRAWN	DATE	TITLE	Amphenol RF www.amphenolrf.com DRAWING NO. A-IPAX137-XXXZY ITEM NO. A-IPAX137-XXXZY PART NO. A-IPAX137-XXXZY
	-	E WANKOFF	19-May-14		
	REFERENCE	ENGINEER	DATE	SCALE: 8.0:1.0 SHEET 2 OF 2	
	EAR # 1434 AND	E WANKOFF	19-May-14	DWG SIZE B REV F	
CONFIGURATION LEVEL: In Work	APPROVED	DATE			
FINISH	K. CAPOZZI	10/2/14			