

REV.	DATE	DESCRIPTION
A	04/28/97	CHANGE GOLD PLATING SPEC.

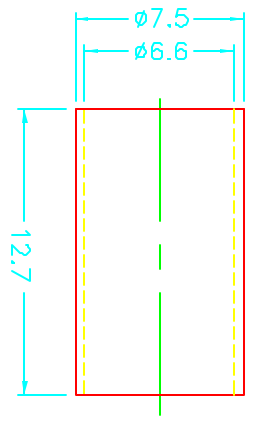

- NOTES: FINISH (PLATING THICKNESS IN MICRO-INCHES)
1. NICKEL PL. 100 MIN. OVER COPPER PL. 50 MIN.
 2. GOLD PL. 15 MIN. OVER NICKEL PL. 50 MIN. OVER COPPER PL. 50 MIN.
 3. TEFLON MIL-P-19468.

DESCRIPTION	MATERIAL	FINISH	DIMENSIONS ARE IN MILLIMETERS UNLESS OTHERWISE SPECIFIED TOLERANCES ARE		APPROVALS	DATE	TITLE			REV.
1 BODY	BRASS	NICKEL	0.5-8 = ± 0.2	DRAWN	G.R.S.	04/28/97	BNC CRIMP PLUG (VPM2000 CABLE- 75ohms)			A
2 INSULATOR	TEFLON	NATURAL	6-30 = ± 0.4	CHECKED			Connector Corporation			
3 CONTACT PIN	BRASS	GOLD	30-120 = ± 0.6	ISSUED			112956			
4 FERRULE	BRASS	NICKEL	120-315 = ± 1				112956.DWG			
5			315-1000 = ± 1.6				112956			
6			1000-2000 = ± 2.4				112956			
7							112956			
8							112956			

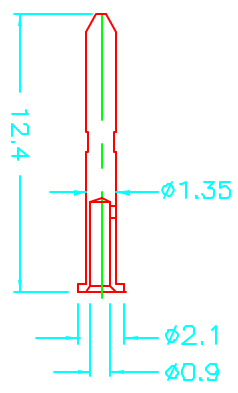
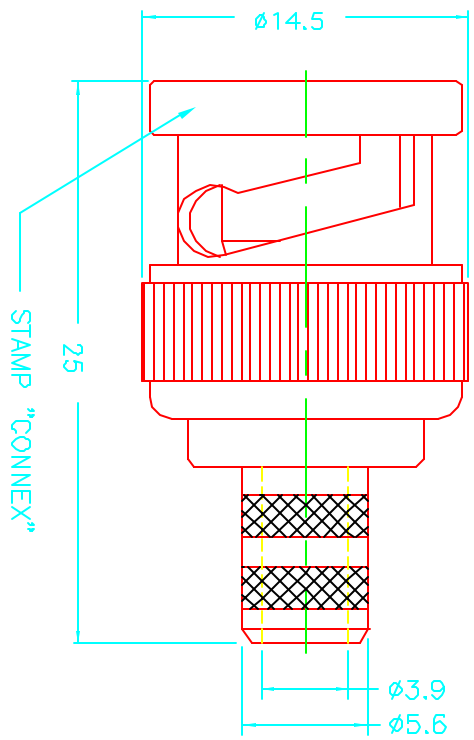
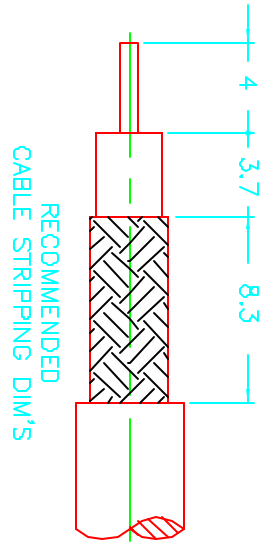

Connector Corporation

BNC CRIMP PLUG
(VPM2000 CABLE- 75ohms)

SCALE 3:1 PART NO. 112956 SHEET 1 OF 1