

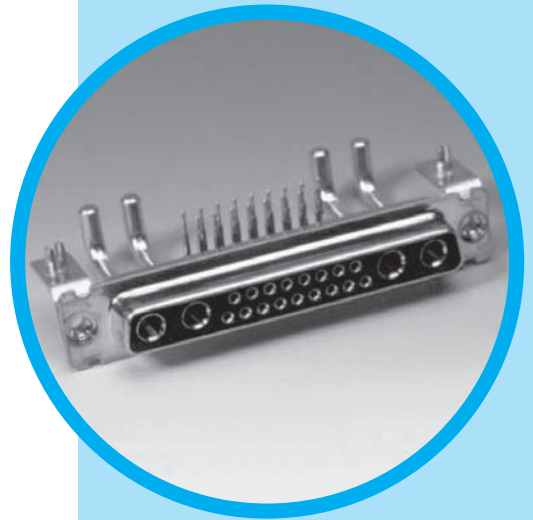

TW

Hybrid D'Sub series



CONTENT

Specifications

- Connectors according to: MIL C24308 - NFC93425 - HE507

Materials and plating		Electrical Data	
Shells	Steel-Tin plating	Current rating	
Insulators	High temperature black thermoplastic	Signal contacts	7.5 A. with 10 A. peak
Signal contacts	Female: machined bronze	Power contacts	
Material	Male: machined brass	PCB terminations	10 to 40 A.
Plating finish	Flash, 15µ" Au over 79µ" Ni min. or 30µ" Au over 79µ" Ni min.	Solder cup terminations	10 to 40 A.
Shielded contacts	Female: machined bronze	Crimp terminations	10 to 40 A.
Material	Male: machined brass	Shielded contacts	0.5 A.
Plating		Voltage rating	
Inner conductor	15µ" Au or 30µ" Au over 79µ" Ni	Signal and power contacts	300 V.R.M.S. at 50 Hz
Outer ring	Flash Au over 79µ" Ni	Shielded contacts	150 V.R.M.S. at 50 Hz
Terminations	Tinned	Shielded contacts	
Except solder cup and crimp terminations	30µ" Au	Frequency range	0-1 GHz
Power contacts	Female: machined bronze	Attenuation	0.2dB
Material	Male: machined brass	V. S. W. R.	1.4(+0.04/GHz)
Plating		Characteristic impedance	50 Ohms
Contacts	Flash, 15µ" Au or 30µ" Au over 79µ" Ni	Dielectric withstanding voltage	≥ 1000 V.R.M.S. at 50Hz
Terminations	Tinned	Insulation resistance	≥ 5000 M Ohms at 500 VDC
Except solder cup and crimp terminations	15µ" Au	Contact resistance	≤ 5m Ohms
Brackets	Steel-Tin plating	Shell resistance (electrical grounding)	≤ 1m Ohm
Front jackscrews	Brass-Tin plating		
Rear clinch nuts	Brass-Tin plating		
Boardlocks	Bronze-Tin plating		
Stand-off	Brass-Tin plating		

Climatic Data		Mechanical data	
Operating temperature	-55°C +155°C (with peak of 180°C)	Shells	With or without dimples
Damp heat	56 days (40°C -95% RH)	Contact retention force in dielectric material	> 40N
Salt spray	48 hours	Maximum mating and unmating force	
		With dimples	E size = 70 N A size = 80 N B size = 100 N C size = 150 N D size = 180 N
		Without dimples	E size = 30 N A size = 50 N B size = 80 N C size = 120 N D size = 160 N
		Compatible with process	
		IR - Air convection	260°C for 20s.
		Resistance to solder iron heat	260°C for 30s.
		Mating cycles	100 (class III) 200 (class II) 500 (class I)

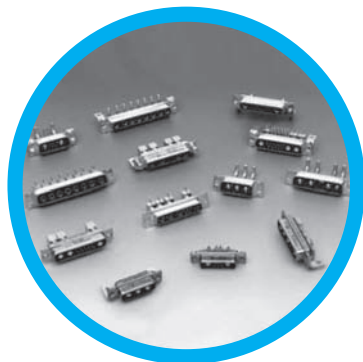

DESCRIPTION

Amphenol D'Sub TW Hybrid Series permits a mix of contacts including signal, power, shielded, high voltage and fiber optics in the same housing with different contacts arrangements.

This economic series was first developed from our military series, and has improved features:

- new contacts
- new high temperature black thermoplastic insert
- PCB configurations come preloaded with fixed contacts and brackets.

These connectors are supplied with screw machined contacts fixed in the insulator.

A complete range of housings are also available for cable application.

A full series of arrangements compatible with reflow process

APPLICATIONS

- Commercial
- Medical
- Industrial
- Telecom
- Any application requiring optimization of space



Amphenol





















TW / E1

Shell and contact plating

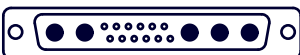
CLASS 3 Flash Gold Signal & Power		CLASS 2 .4um(15u") Signal, Power, Coax		CLASS 1 .76um(30u") Signal, Power Coax	
Type	Shell + Plating	Type	Shell + Plating	Type	Shell + Plating
76	Tin plated shell Plug or Socket	77	Tin plated shell Plug or Socket	177	Tin plated shell Plug or Socket
716	Tin plated shell with grounding dimples-plug only	717	Tin plated shell with grounding dimples-plug only	777	Tin plated shell with grounding dimples-plug only

Housing arrangement

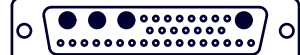
Male front view

Arrangement... Shell size.....	 2W2 E	 P2W2 E	 P3W3 E
Arrangement... Shell size.....	 5W1 A	 7W2 A	 11W1 A
Arrangement... Shell size.....	 3W3 A	 5W5 B	 9W4 B
Arrangement... Shell size.....	 13W3 B	 17w2 B	 21W1 B
Arrangement... Shell size.....	 27W2 C	 13W6 C	 17W5 C
Arrangement... Shell size.....	 21WA4 C	 8W8 C	 25W3 C
Arrangement... Shell size.....	 24W7 D	 36W4 D	 43W2 D

Shell size dimensions

Rear view

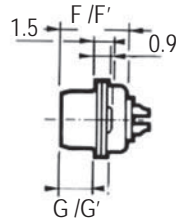
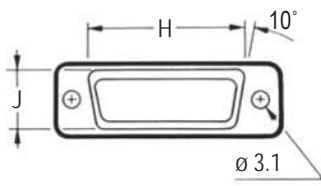

Front view

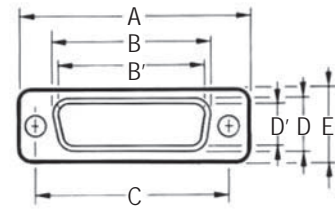

Shell size	Contact P: Pin S: Socket	A ±0.25 (±.010)	B 0/-0.20 (0/- .008)	B' +0.20/0 (+.008/0)	C ±0.10 (±.004)	D 0/-0.25 (0/- .010)	D' +0.25/0 (+.010/0)	E ±0.20 (±.008)	F +0.05/-0.20 (+.002/- .008)	F' +0.10/-0.20 (+.004/- .008)	G +0.10/-0.20 (+.004/- .008)	G' ±0.10 (±.004)	H +0.10/-0.40 (+.004/- .016)	J 0/-0.50 (0/- .020)
E	P	30.7 (1.209")		16.8 (.661")	25.0 (.984")		8.2 (.323")	12.4 (.488")		10.9 (.429")		5.9 (.232")	19.4 (.764")	11.0 (.433")
	S		16.4 (.646")			8.0 (.315")			11.1 (.437")		6.2 (.244")			
A	P	39.0 (1.535")		25.1 (.988")	33.3 (1.311")		8.2 (.323")	12.4 (.488")		10.9 (.429")		5.9 (.232")	27.7 (1.091")	11.0 (.433")
	S		24.8 (.976")			8.0 (.315")			11.1 (.437")		6.2 (.244")			
B	P	52.9 (2.083")		38.8 (1.528")	47.0 (1.850")		8.2 (.323")	12.4 (.488")		11.0 (.433")		5.8 (.228")	41.4 (1.630")	11.0 (.433")
	S		38.5 (1.513")			8.0 (.315")			11.1 (.437")		6.2 (.244")			
C	P	69.2 (2.724")		55.3 (2.177")	63.5 (2.500")		8.2 (.323")	12.4 (.488")		11.0 (.433")		5.8 (.228")	57.9 (2.280")	11.0 (.433")
	S		54.9 (2.161")			8.0 (.315")			11.1 (.437")		6.2 (.244")			
D	P	66.8 (2.630")		52.7 (2.075")	61.1 (2.406")		11.0 (.433")	15.2 (.598")		11.0 (.433")		5.8 (.228")	55.5 (2.185")	13.8 (.543")
	S		52.5 (2.067")			10.9 (.429")			11.1 (.437")		6.2 (.244")			

Panel cutouts

Optimal cutout for rear mounting

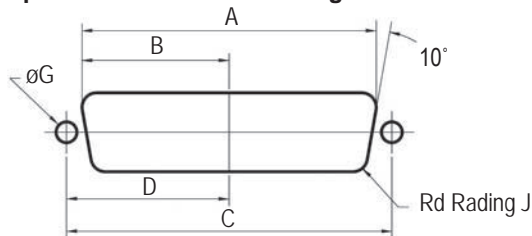

Standard cutout

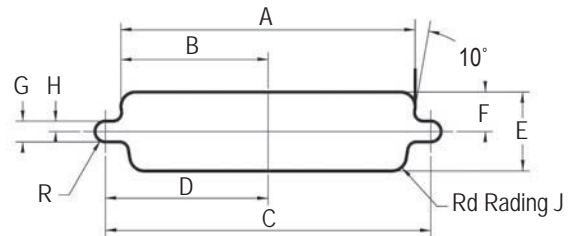

Shell size	Mounting method	A ±0.20 (±.008)	B ±0.20 (±.008)	C ±0.20 (±.008)	D ±0.20 (±.008)	E ±0.20 (±.008)	F ±0.20 (±.008)	G ±0.20 (±.008)	H ±0.20 (±.008)	J ±0.20 (±.008)
E	Front	22.2 (.874")	11.1 (.437")	25.0 (.984")	12.5 (.492")	13.0 (.512")	6.5 (.256")	3.0 (.118")	1.5 (.059")	2.1 (.083")
	Rear	20.5 (.807")	10.2 (.402")							3.4 (.134")
A	Front	30.5 (1.201")	15.3 (.602")	33.3 (1.311")	16.7 (.657")	13.0 (.512")	6.5 (.256")	3.0 (.118")	1.5 (.059")	2.1 (.083")
	Rear	28.8 (1.134")	14.4 (.567")							3.4 (.134")
B	Front	44.3 (1.744")	22.1 (.870")	47.0 (1.850")	23.5 (.925")	13.0 (.512")	6.5 (.256")	3.0 (.118")	1.5 (.059")	2.1 (.083")
	Rear	42.5 (1.673")	21.3 (.839")							3.4 (.134")
C	Front	60.7 (2.390")	30.4 (1.197")	63.5 (2.500")	31.7 (1.248")	13.0 (.512")	6.5 (.256")	3.0 (.118")	1.5 (.059")	2.1 (.083")
	Rear	59.1 (2.327")	29.5 (1.161")							3.4 (.134")
D	Front	58.3 (2.295")	29.2 (1.150")	61.1 (2.406")	30.6 (1.205")	15.8 (.622")	7.9 (.311")	3.0 (.118")	1.5 (.059")	2.1 (.083")
	Rear	56.3 (2.217")	28.2 (1.110")							3.4 (.134")

Straight connector footprint

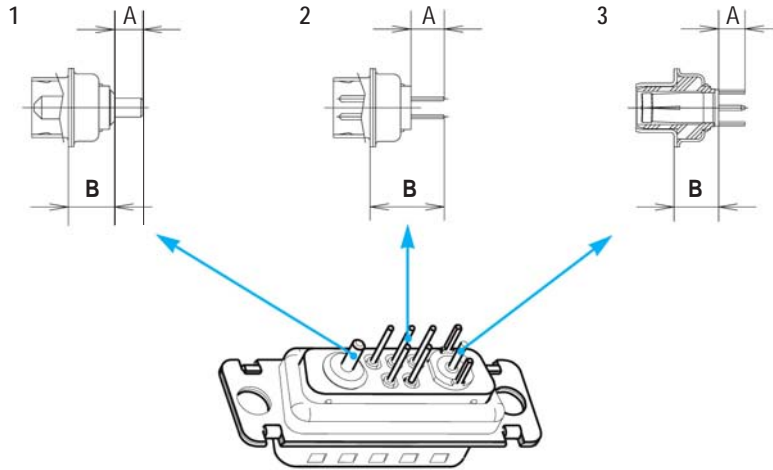

Signal tail 0.6 mm Dia. (.024")
 1.6 mm (.063")PCB
 For other PCB thickness: consult factory.

Description		Dimensions	
		a	b
Power 3.2mm(.126") tail dia	1	4.80 mm (.189")	7.2 mm (.283")
Power 2.0mm(.078") tail dia	1	4.80 mm (.189")	7.2 mm (.283")
Shielded	3	4.00 mm (.157")	7.2 mm (.283")
Signal	2	5.30 mm (.209")	11.50 mm (.453")

Straight contact combinations

Arrangement with signal contacts

Arrangement without signal contacts
 2W2 - 3W3 - 5W5 - 8W8

See above dimensions	Size 8 and 20 Contacts	See above dimensions	Size 8 Contacts
P 3SY	Power 3.2 mm DIA. (.126") (20 to 40 A) and signal	P 3Y	Power only 3.2 mm DIA. (.126") (20 to 40 A)
P 2SY	Power 2 mm DIA. (.078") (10 to 20 A) and signal	P 2Y	Power only 2 mm DIA. (.078") (10 to 20 A)
CSY	Shielded and signal	CY	Shielded only
SY	Signal only		
No reference	Signal (Size 20) with solder cup terminations <i>Housing preloaded with contacts</i>		

Right angle connector footprint

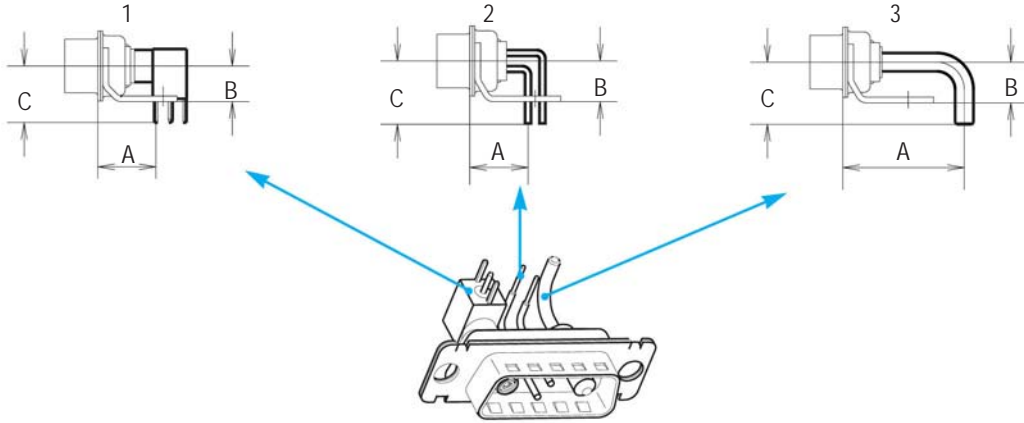

Signal tail 0.6 mm Dia. (.0236")
 1.6 mm (.063") PCB
 For other PCB thickness: consult factory.

Description	Europe			Mix			MIL			
	a	b	c	a	b	c	a	b	c	
Shielded	1	-	-	-	-	-	-	-	-	
Signal	2	10.30mm (.406")	7.20mm (.283")	11.20mm (.441")	10.30mm (.406")	6.30mm (.248")	9.50mm (.374")	8.10mm (.319")	6.30mm (.248")	9.50mm (.374")
Power 2.0mm(.078") tail dia	3	11.57mm (.456")	7.20mm (.283")	10.50mm (.413")	11.57mm (.456")	6.30mm (.248")	9.50mm (.374")	9.52mm (.375")	6.30mm (.248")	9.50mm (.374")
Power 3.2mm(.126") tail dia	3	21.46mm (.845")	7.20mm (.283")	10.50mm (.413")	21.46mm (.845")	6.30mm (.248")	9.50mm (.374")	21.46mm (.845")	6.30mm (.248")	9.50mm (.374")

Note: above dimensions correspond to sizes E to C. Consult factory for D sizes.
 Connector comes equipped with contacts and brackets.

Right angle contacts combinations

Arrangement with signal contacts

Arrangement without signal contacts
 2W2 - 3W3 - 5W5 - 8W8

European footprint	Mixed footprint	MIL (U.S.) footprint	Size 8 and 20 Contacts	European footprint	Mixed footprint	MIL (U.S.) footprint	Size 8 contacts only
EP3SV	HP3SV	MP3SV	Power 3.2 mm DIA. (.126") (20 to 40 A) and signal	EP3V	HP3V	MP3V	Power only 3.2 mm DIA. (.126") (20 to 40 A)
EP2SV	HP2SV	MP2SV	Power 2 mm DIA. (.078") (10 to 20 A) and signal	EP2V	HP2V	MP2V	Power only 2.0 mm DIA. (.078") (10 to 20 A)
-	HCSV	MCSV	Shielded and signal	-	HCV	MCV	Shielded only
ESV	HSV	MSV	Signal only				

Mounting options

Right angle version

Connectors come equipped with metal brackets

BLANK: 3.10mm (.122") dia mounting hole

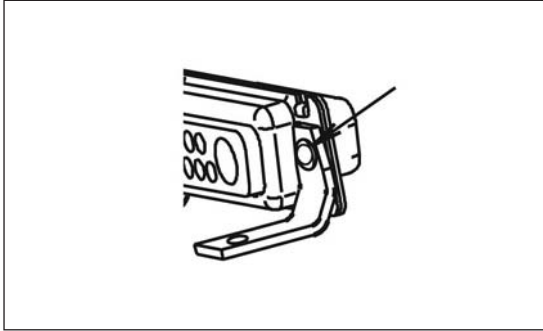

RM6: metal brackets + boardlock

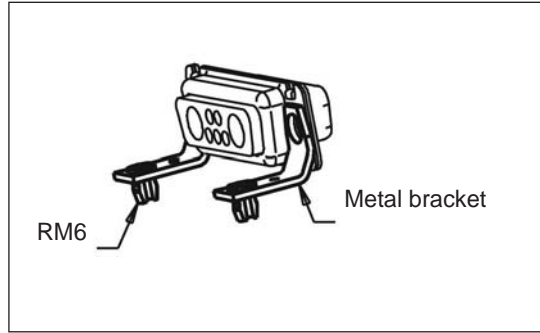

Straight version

BLANK: 3.10mm (.122") dia mounting hole

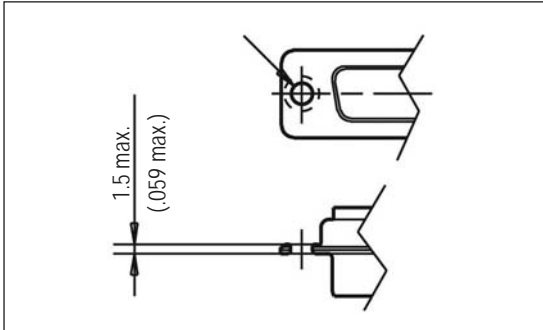

RM54: 4-40 threaded

RM53: M3 threaded

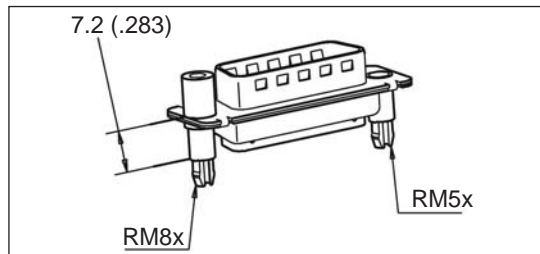

RM84: 4-40 threaded

RM83: M3 threaded

A514: blind mating system

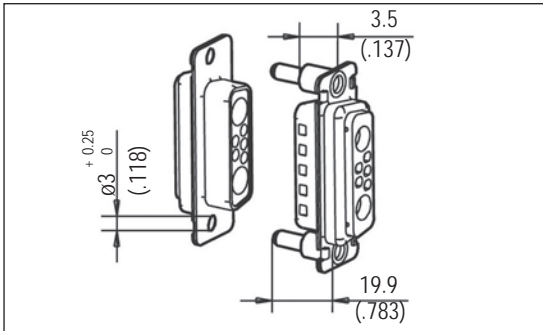

FM: float mounting system

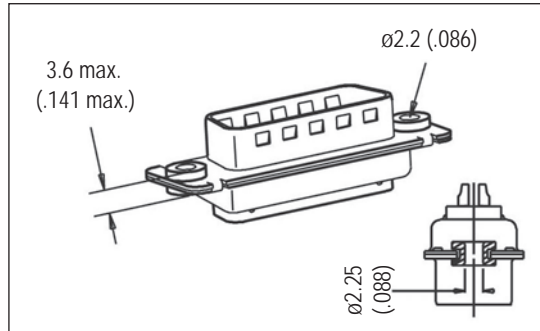

Straight and right angle version

4R: 4-40 rear nut

3R: M3 rear nut

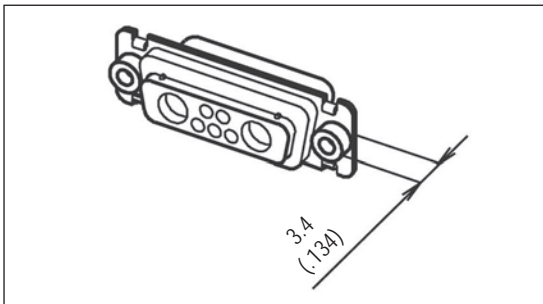

4F: 4-40 front female screwlock

3F: M3 front female screwlock

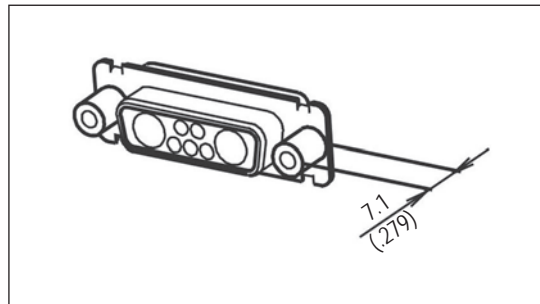

High power contacts

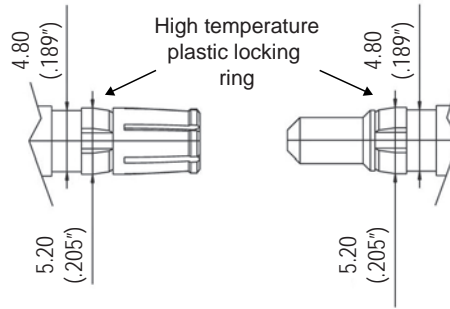

Solder cup version

Technical drawings of solder cup version contacts. The left drawing shows a side view with dimensions 22 (.866"), ϕA , and ϕB . The right drawing shows a top view with dimensions 22 (.866"), ϕA , and ϕB . A third drawing shows a side view of the solder cup with a dimension of 16 (.622").

P/N		Current	Dimensions	
Plug	Socket		A mm (inch)	B mm (inch)
L 17DM 53745-8	L 17DM 53744-7	10 to 20 Amp.	1.80 (.071")	2.55 (.100")
L 17DM 53745-7	L 17DM 53744-6	20 to 30 Amp.	2.80 (.110")	3.70 (.145")
L 17DM 53745-1	L 17DM 53744-1	30 to 40 Amp.	4.80 (.189")	5.60 (.220")

Trim dimensions: 7.5 mm (.295")

Crimp version

Technical drawings of crimp version contacts. The left drawing shows a side view with dimensions 22 (.866"), ϕA , and ϕB . The right drawing shows a top view with dimensions 22 (.866"), ϕA , and ϕB . A third drawing shows a side view of the crimp with a dimension of 16 (.622").

P/N		Current	Dimensions	
Plug	Socket		A mm (inch)	B mm (inch)
L 17DM 53745-208	L 17DM 53744-207	10 to 20 Amp.	1.80 (.071")	2.55 (.100")
L 17DM 53745-207	L 17DM 53744-206	20 to 30 Amp.	2.80 (.110")	3.70 (.145")
L 17DM 53745-201	L 17DM 53744-201	30 to 40 Amp.	4.80 (.189")	5.60 (.220")

Trim dimensions: 7.5 mm (.295")

Contact plating	Part number option
Flash Gold	17DMxxxxx-x G
0.4 μ m(15 μ " Au	Standard part number as above
0.76 μ m(30 μ " Au	17DMxxxxx-x C309

Straight shielded contacts

Crimp ferrule and inner solder

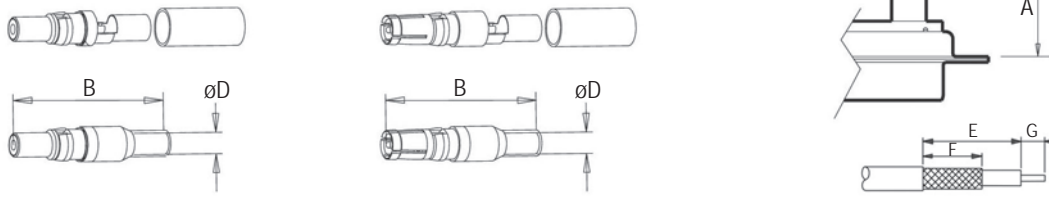

Type	P/N	Dimensions (inch)			Cable - RG	Trim dimensions (inch)		
		A Max	B	D		E	F	G
plug	L17DM 53740	18.8 (740")	23.6 (.929")	1.0 (.039")	178 B/U	7.9 (.311")	6.3 (.248")	2 (.078")
plug	L17DM 53740-1	18.8 (740")	23.6 (.929")	1.7 (.066")	179 B/U 316 B/U	7.9 (.311")	6.3 (.248")	2 (.078")
plug	L17DM 53740-3	21.5 (846")	23.6 (.929")	2.8 (.110")	180 B/U	9.5 (.374")	7.9 (.311")	2 (.078")
plug	L17DM 53740-5	21.5 (846")	23.6 (.929")	3.2 (.126")	58 C/U	9.5 (.374")	7.9 (.311")	2 (.078")
socket	L17DM 53742	18.8 (740")	23.6 (.929")	1.0 (.039")	178 B/U	7.9 (.311")	6.3 (.248")	2 (.078")
socket	L17DM 53742-1	18.8 (740")	23.6 (.929")	1.7 (.066")	179 B/U 316 B/U	7.9 (.311")	6.3 (.248")	2 (.078")
socket	L17DM 53742-3	21.5 (846")	23.6 (.929")	2.8 (.110")	180 B/U	9.5 (.374")	7.9 (.311")	2 (.078")
socket	L17DM 53742-5	21.5 (846")	23.6 (.929")	3.2 (.126")	58 C/U	9.5 (.374")	7.9 (.311")	2 (.078")

Ferrule and inner solder

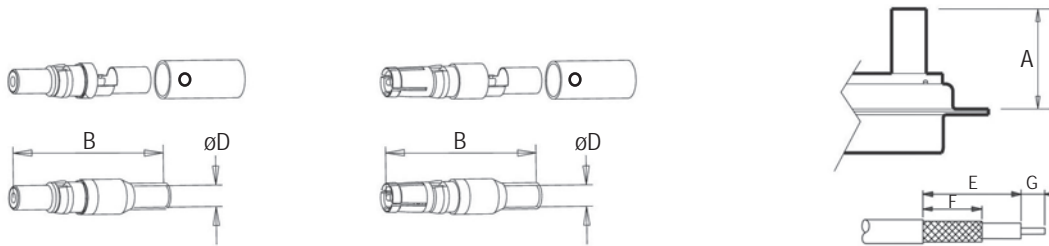

Type	P/N	Dimensions (inch)			Cable - RG	Trim dimensions (inch)		
		A Max	B	D		E	F	G
short plug	L17DM 53740-5000	17.0 (669")	21.8 (.858")	1.0 (.039")	178 B/U	7.9 (.311")	6.3 (.248")	2 (.078")
plug	L17DM 53740-5001	18.8 (740")	23.6 (.929")	1.7 (.066")	179 B/U 316 B/U	7.9 (.311")	6.3 (.248")	2 (.078")
plug	L17DM 53740-5002	21.5 (846")	26.3 (1.035")	2.8 (.110")	180 B/U	9.5 (.374")	7.9 (.311")	2 (.078")
plug	L17DM 53740-5005	21.5 (846")	26.3 (1.035")	3.2 (.126")	58 C/U	9.5 (.374")	7.9 (.311")	2 (.078")
plug	L17DM 53740-5008	18.8 (740")	23.6 (.929")	1.0 (.039")	178 B/U	7.9 (.311")	6.3 (.248")	2 (.078")
short socket	L17DM 53742-5000	17.0 (669")	21.8 (.858")	1.0 (.039")	178 B/U	7.9 (.311")	6.3 (.248")	2 (.078")
socket	L17DM 53742-5001	18.8 (740")	23.6 (.929")	1.7 (.066")	179 B/U 316 B/U	7.9 (.311")	6.3 (.248")	2 (.078")
socket	L17DM 53742-5002	21.5 (846")	26.3 (1.035")	2.8 (.110")	180 B/U	9.5 (.374")	7.9 (.311")	2 (.078")
socket	L17DM 53742-5004	21.5 (846")	26.3 (1.035")	3.2 (.126")	58 C/U	9.5 (.374")	7.9 (.311")	2 (.078")
socket	L17DM 53742-5006	18.8 (740")	23.6 (.929")	1.0 (.039")	178 B/U	7.9 (.311")	6.3 (.248")	2 (.078")

Right angled shielded contact

Crimp ferrule and inner solder

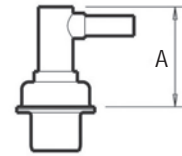
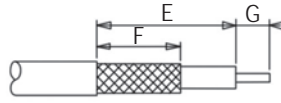
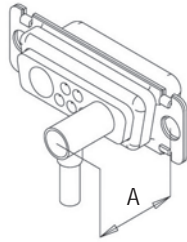

Type	P/N	Dimensions (inch)			Cable - RG	Trim dimensions (inch)		
		A Max	B	D		E	F	G
plug	L17DM 53741	13.5 (.531")	18.6 (.732")	1.0 (.039")	178 B/U	9.5 (.374")	5.9 (.232")	1.6 (.062")
plug	L17DM 53741-1	13.5 (.531")	18.6 (.732")	1.7 (.066")	179 B/U 316 B/U	9.5 (.374")	5.9 (.232")	1.6 (.062")
plug	L17DM 53741-3	13.5 (.531")	18.6 (.732")	2.8 (.110")	180 B/U	10.7 (.421")	7.9 (.311")	2.4 (.094")
plug	L17DM 53741-4	13.5 (.531")	18.6 (.732")	3.2 (.126")	58 C/U	10.7 (.421")	7.9 (.311")	2.4 (.094")
socket	L17DM 53743-2	13.5 (.531")	18.6 (.732")	1.0 (.039")	178 B/U	9.5 (.374")	5.9 (.232")	1.6 (.062")
socket	L17DM 53743-3	13.5 (.531")	18.6 (.732")	1.7 (.066")	179 B/U 316 B/U	9.5 (.374")	5.9 (.232")	1.6 (.062")
socket	L17DM 53743-5	13.5 (.531")	18.6 (.732")	2.8 (.110")	180 B/U	10.7 (.421")	7.9 (.311")	2.4 (.094")
socket	L17DM 53743-6	13.5 (.531")	18.6 (.732")	3.2 (.126")	58 C/U	10.7 (.421")	7.9 (.311")	2.4 (.094")

Ferrule and inner solder

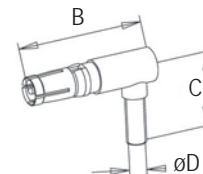
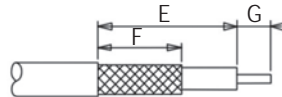
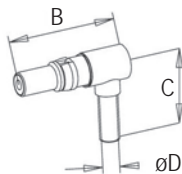

Type	P/N	Dimensions (inch)			Cable - RG	Trim dimensions (inch)		
		A Max	B	D		E	F	G
plug	L17DM 53741-5000	13.5 (.531")	18.6 (.732")	1.0 (.039")	178 B/U	9.5 (.374")	5.9 (.232")	1.6 (.062")
plug	L17DM 53741-5001	13.5 (.531")	18.6 (.732")	1.7 (.066")	179 B/U 316 B/U	9.5 (.374")	5.9 (.232")	1.6 (.062")
plug	L17DM 53741-5003	13.5 (.531")	18.6 (.732")	2.8 (.110")	180 B/U	10.7 (.421")	7.9 (.311")	2.4 (.094")
plug	L17DM 53741-5004	13.5 (.531")	18.6 (.732")	3.2 (.126")	58 C/U	10.7 (.421")	7.9 (.311")	2.4 (.094")
socket	L17DM 53743-5000	13.5 (.531")	18.6 (.732")	1.0 (.039")	178 B/U	9.5 (.374")	5.9 (.232")	1.6 (.062")
socket	L17DM 53743-5001	13.5 (.531")	18.6 (.732")	1.7 (.066")	179 B/U 316 B/U	9.5 (.374")	5.9 (.232")	1.6 (.062")
socket	L17DM 53743-5003	13.5 (.531")	18.6 (.732")	2.8 (.110")	180 B/U	10.7 (.421")	7.9 (.311")	2.4 (.094")
socket	L17DM 53743-5004	13.5 (.531")	18.6 (.732")	3.2 (.126")	58 C/U	10.7 (.421")	7.9 (.311")	2.4 (.094")

Crimping tool

Hand crimp tool

227-0944 (without dies) (M 22 520/5-01)

RG cables	MIL reference	Amphenol P/N	dim. between 2 at surface	
			cavity A	cavity B
RG 58 C/U	M 22 520/5-05	227 1221-05	5.41	-
RG 178 B/U	M 22 520/5-03	227 1221-03	-	2.67
RG 179 B/U	M 22 520/5-03	227 1221-03	3.25	-
RG 180 B/U	M 22 520/5-05	227 1221-05	-	4.52

Extraction & crimping tools

Extraction tool for sizes 8 cts

L17D429SP



Crimping tool for all sizes

L17D479SP



Cabling instructions for shielded contacts

Straight crimp shielded contacts:

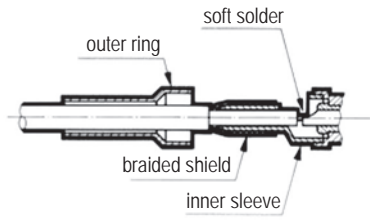

inner solder contact outer crimp contact

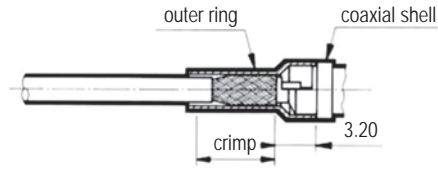

Right angle crimp shielded contacts:

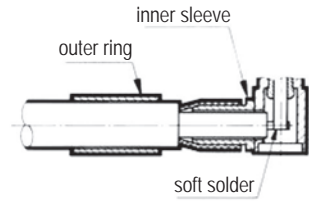

inner solder contact outer crimp contact

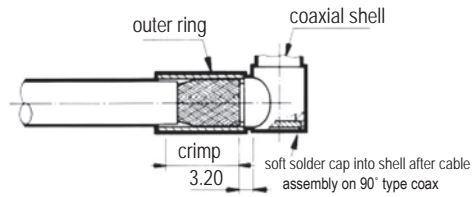

Assembly method

- Slide the outer ring over the cable jacket. Trim the cable according to the recommended dimensions.
- Insert the cable dielectric and the center conductor inside the inner sleeve.
- Solder the central conductor to the shielded center contacts.
- Slide the outer ring towards the inner sleeve and recover the braid.
- Using crimp hand tool equipped with the appropriate dies, crimp in the area defined.

Solder straight shielded contacts:

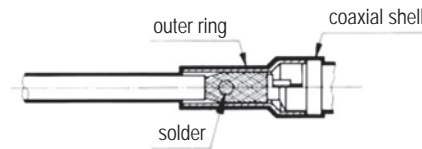
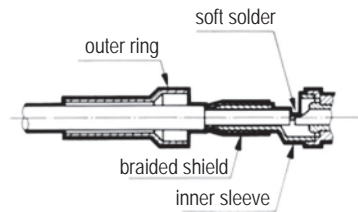

Solder right angle shielded contacts:

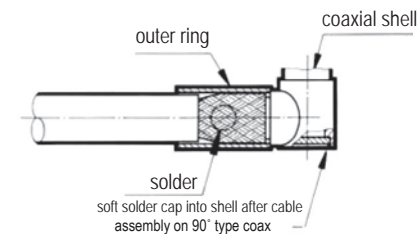
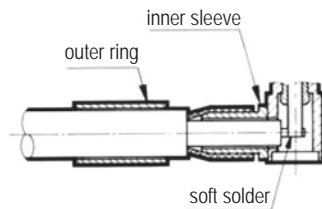

Assembly method

- Slide the outer ring over the cable jacket. Trim the cable according to the recommended dimensions.
- Insert the cable dielectric and the center conductor inside the inner sleeve.
- Solder the central conductor to the shielded center contacts.
- Slide the outer ring towards the inner sleeve and recover the braid.
- Solder by introducing metal through the outer ring hole.

How to build your part number

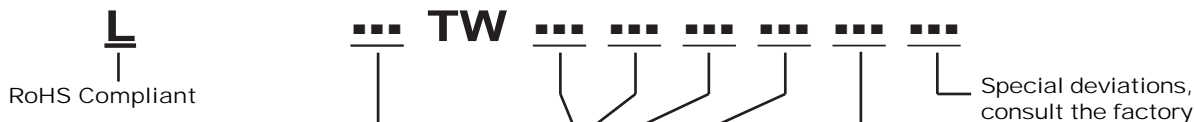

Shell & Contact Plating Options		
Shell		Contact Plating
Tinned	Tinned +Dimples*	
76	716	Flash Gold**
77	717	0.4µm(15µ") Au
77	717	0.76µm(30µ") Au

* Plug only
** Signal and Power contacts only

Shell Size and Configuration				
E2W2	*P2W2	E5W1	A3W3	*P3W3
A7W2	A11W1	B5W5	B9W4	B13W3
B17W2	B21W1	C8W8	C13W6	C17W5
C21WA4	C25W3	C27W2	D24W7	D36W4
D43W2	♦ Keyed housing			

When choosing VF or VFM panel mount options, either H (4-40) or G (M3) must be used for rear threaded insert.
Example: E H 5W1

Gender	
P	= Plug (Pin)
S	= Socket

PCB Mounting Options	
<u>Straight</u>	
BLANK	= 3.1mm(.122") clear hole
RM53	= M3 threaded standoff with boardlocks
RM54	= 4-40 threaded standoff with boardlocks
RM83	= Fixed M3 front screwlock + stand-off & boardlocks
RM84	= Fixed 4-40 front screwlock + stand-off & boardlocks
<u>Right Angle</u>	
BLANK	= 3.1mm(.122") clear hole
RM6	= Metal bracket + boardlocks

Panel Mounting Options	
BLANK	= 3.1mm(.122") clear hole
3F	= M3 fixed front screwlock
3R	= M3 rear threaded insert
4F	= 4-40 fixed front screwlock
3R	= 4-40 rear threaded insert
VFM	= M3 removable front screwlock (use H or G for rear threaded insert)
VF	= 4-40 removable front screwlock (use H or G for rear threaded insert)
FM	= Float mount bushing
A514	= Blind mate guide pin

Terminations

Straight PCB & Solder-cup

- BLANK = Solder-cup signal contacts only
- P3SY = 20~40Amp power & signal mix
- P2SY = 10~20Amp power & signal mix
- CSY = Coax & signal mix
- SY = Signal only
- P3Y = 20~40Amp power only (2W2, 3W3, 5W5, 8W8)
- P2Y = 10~20Amp power only (2W2, 3W3, 5W5, 8W8)
- CY = Coax only (2W2, 3W3, 5W5, 8W8)

Right Angle PCB

- MP3SV = US footprint, 20~40Amp power & signal mix
- MP2SV = US footprint, 10~20Amp power & signal mix
- MCSV = US footprint, coax & signal mix
- MSV = US footprint, signal only
- MP3V = US footprint, 20~40Amp power only (2w2, 3W3, 5W5, 8W8)
- MP2V = US footprint, 10~20Amp power only (2w2, 3W3, 5W5, 8W8)

Right Angle PCB cont.

- MCV = US footprint, coax only (2W2, 3W3, 5W5, 8W8)
- EP3SV = European footprint, 20~40Amp power & signal mix
- EP2SV = European footprint, 10~20Amp power & signal mix
- ESV = European footprint, signal only
- EP3V = European footprint, 20~40Amp power only (2W2, 3W3, 5W5, 8W8)
- EP2V = European footprint, 10~20Amp power only (2W2, 3W3, 5W5, 8W8)
- HP3SV = Mixed footprint, 20~40Amp power & signal mix
- HP2SV = Mixed footprint, 10~20Amp power & signal mix
- HCSV = Mixed footprint, coax & signal mix
- HSV = Mixed footprint, signal only
- HP3V = Mixed footprint, 20~40Amp power only (2W2, 3W3, 5W5, 8W8)
- HP2V = Mixed footprint, 10~20Amp power only (2W2, 3W3, 5W5, 8W8)
- HCV = Mixed footprint, coax only (2W2, 3W3, 5W5, 8W8)

Example: L717 TW B9W4 S MP3V 4F RM6

