

ABB AP

Catalogue No. AC1240

AC1240

DISCONNECT SWITCHES



Disconnect Switches  
Fusible Non-fusible Enclosed  
Cam switches

Printed in Canada (March 2010)  
Subject to modification.



**ABB**  
2117, 32e Avenue  
Lachine, QC H8T 3J1  
Tel: 514-420-3100  
Toll free: 1-800-567-0283  
Fax: 514-420-3137

Website: [www.abb.ca](http://www.abb.ca)

**ABB**

**ABB**

**ABB**

# Disconnect switches



## Disconnect Switches

- Compact, heavy duty

### SwitchLine

Non-fusible disconnect switches .....1.1 - 1.54

### PowerLine

Fusible disconnect switches .....2.1 - 2.39

### SafeLine

Enclosed disconnect switches .....3.1 - 3.12

### Cam switches

OM, ON, OL cam switches .....4.1 - 4.54

This catalog is published for information purposes only and is not all inclusive. For additional information on products or technical information, consult ABB. The installation and use of ABB products should be in accordance with the provisions of the Canadian Electrical Code and/or other local codes or industry standards that are pertinent to the particular end use. Installation or use not in accordance with these codes and standards could be hazardous to personnel and/or equipment.

## Quick Information

Put a checkmark in the boxes below and fax it to your nearest ABB office to receive more information.

Please fill in the following information (or attach a business card).

Name \_\_\_\_\_

Company \_\_\_\_\_

Address \_\_\_\_\_

City \_\_\_\_\_ Prov. \_\_\_\_\_ Postal Code \_\_\_\_\_

Telephone \_\_\_\_\_ Fax \_\_\_\_\_

### Control Products

- AC & DC Contactors
- Cam Switches
- Definite Purpose Contactors
- Drive Contactors
- Electronic Timers
- Lighting Contactors
- Limit Switches
- Magnetic Starters
- Manual Motor Starters
- PLC
- Pushbuttons, Stacklights and Beacons
- Relays
- Safety and Monitoring Relays
- Softstarters
- Wiring Ducts

### Circuit Protective Devices

- Arc Guard Monitor
- Disconnect Switches, Fusible and Non-Fusible
- Low Voltage Power Circuit Breakers
- Molded Case Circuit Breakers
- Supplementary Protectors

### Power Quality Products

- Active Filter
- Anti-Resonance Capacitor Banks
- Automatic Capacitor Banks
- Dynacomp
- Fixed Capacitor Banks
- Harmonic Filter (shunt)
- Individual Capacitors
- Surge Capacitor

### Entrelec Products

- Analog Converters
- Digital Converters
- Industrial pluggable relays & Optos
- Logic Control relay
- Overvoltage protection
- PCB connectors
- PLB connectors
- PLC's Pre-wiring system
- Power Blocks
- Power Supplies
- Remote Input/Output
- Rotary switches
- Terminal Blocks
- Timers & Monitoring (Entrelec & SSAC)

#### Eastern Region

ABB Inc.  
**Head Office**  
 2117, 32e Avenue  
 Lachine, QC H8T 3J1  
 Tel: 514-420-3100  
 Toll free: 1-800-567-0283  
 Fax: 514-420-3137

#### Central Region

ABB Inc.  
 201 Westcreek Blvd.  
 Brampton, ON L6T 5S6  
 Tel.: +1 905-460-3000  
 Toll free: 1-866-460-3300  
 Fax: +1 905-460-3395

#### Mid-West Region

ABB Inc.  
**Blackfoot Corporate Centre**  
 1110, 4411 - 6th Street SE  
 Calgary, AB T2G 4E8  
 Tel: +1 403-278-7111  
 Toll free: 1-866-222-8368  
 Fax: +1 403-278-8232

## Quick product finder

Catalogue number	Page	Catalogue number	Page	Catalogue number	Page
CXBY67121	2.8	FJ4001-3P	3.8	NF1001-6P	3.6
CXBY68100	1.16	FJ4001-4P	3.9	NF1002-3P	3.5
CXBY68140	1.16	FJ4001-6P	3.9	NF1002-3T	3.6
CXBY68362	2.11	FJ4002-2P	3.9	NF1002-4P	3.6
CXBY68674	2.11	FJ4002-3P	3.8	NF1002-6P	3.6
CXBY68794	2.11	FJ4002-4P	3.9	NF1004-3P	3.5
CXBY68989	1.16	FJ4002-6P	3.9	NF1004-3T	3.6
CXBY68998	1.16	FJ4004-2P	3.9	NF1004-4P	3.6
DSK8TL	1.9 - 1.21	FJ4004-3P	3.8	NF1004-6P	3.6
DSK8TM	1.9 - 1.21	FJ4004-4P	3.9	NF100X-3P	3.5
EOT16U3P3-1S	3.4	FJ4004-6P	3.9	NF100X-3T	3.6
EOT16U3P3-S	3.4	FJ400X-2P	3.9	NF100X-4P	3.6
EOT16U4P4-1P	3.4	FJ400X-3P	3.8	NF100X-6P	3.6
EOT16U4P4-P	3.4	FJ400X-4P	3.9	NF12001-2P	3.6
EOT32U3P3-1S	3.4	FJ400X-6P	3.9	NF12001-3P	3.5
EOT32U3P3-S	3.4	FJ6001-2P	3.9	NF12001-3T	3.6
EOT32U4P4-1P	3.4	FJ6001-3P	3.8	NF12001-4P	3.6
EOT32U4P4-P	3.4	FJ6001-4P	3.9	NF12001-6P	3.6
EOT45U3P3-1S	3.4	FJ6001-6P	3.9	NF12002-2P	3.6
EOT45U3P3-S	3.4	FJ6002-2P	3.9	NF12002-3P	3.5
EOT45U4P4-1P	3.4	FJ6002-3P	3.8	NF12002-3T	3.6
EOT45U4P4-P	3.4	FJ6002-4P	3.9	NF12002-4P	3.6
FJ1001-2P	3.9	FJ6002-6P	3.9	NF12002-6P	3.6
FJ1001-3P	3.8	FJ6004-2P	3.9	NF12004-2P	3.6
FJ1001-4P	3.9	FJ6004-3P	3.8	NF12004-3P	3.5
FJ1001-6P	3.9	FJ6004-4P	3.9	NF12004-3T	3.6
FJ1002-2P	3.9	FJ6004-6P	3.9	NF12004-4P	3.6
FJ1002-3P	3.8	FJ600X-2P	3.9	NF12004-6P	3.6
FJ1002-4P	3.9	FJ600X-3P	3.8	NF1200X-2P	3.6
FJ1002-6P	3.9	FJ600X-4P	3.9	NF1200X-3T	3.6
FJ1004-2P	3.9	FJ600X-6P	3.9	NF1200X-4P	3.6
FJ1004-3P	3.8	FJ601-3P	3.8	NF1200X-6P	3.6
FJ1004-4P	3.9	FJ601-4P	3.9	NF161-3P	3.4
FJ1004-6P	3.9	FJ601-6P	3.9	NF161-3S	3.4
FJ100X-2P	3.9	FJ602-3P	3.8	NF161-3T	3.6
FJ100X-3P	3.8	FJ602-4P	3.9	NF161-4P	3.6
FJ100X-4P	3.9	FJ602-6P	3.9	NF161-6P	3.6
FJ100X-6P	3.9	FJ604-3P	3.8	NF162-3P	3.4
FJ2001-2P	3.9	FJ604-4P	3.9	NF162-3S	3.4
FJ2001-3P	3.8	FJ604-6P	3.9	NF162-3T	3.6
FJ2001-4P	3.9	FJ60X-2P	3.9	NF162-4P	3.6
FJ2001-6P	3.9	FJ60X-3P	3.8	NF162-6P	3.6
FJ2002-2P	3.9	FJ60X-4P	3.9	NF164-3P	3.4
FJ2002-3P	3.8	FJ60X-6P	3.9	NF164-3T	3.6
FJ2002-4P	3.9	FL8001-2P	3.9	NF164-4P	3.6
FJ2002-6P	3.9	FL8001-3P	3.8	NF164-6P	3.6
FJ2004-2P	3.9	FL8001-4P	3.9	NF16X-3P	3.4
FJ2004-3P	3.8	FL8001-6P	3.9	NF16X-3T	3.6
FJ2004-4P	3.9	FL8002-2P	3.9	NF16X-4P	3.6
FJ2004-6P	3.9	FL8002-3P	3.8	NF16X-6P	3.6
FJ200X-2P	3.9	FL8002-4P	3.9	NF2001-2P	3.6
FJ200X-3P	3.8	FL8002-6P	3.9	NF2001-3C	3.6
FJ200X-4P	3.9	FL8004-2P	3.9	NF2001-3P	3.5
FJ200X-6P	3.9	FL8004-3P	3.8	NF2001-4P	3.6
FJ301-3P	3.8	FL8004-4P	3.9	NF2001-6P	3.6
FJ301-4P	3.9	FL8004-6P	3.9	NF2002-2P	3.6
FJ301-6P	3.9	FL800X-2P	3.9	NF2002-3C	3.6
FJ302-3P	3.8	FL800X-3P	3.8	NF2002-3P	3.5
FJ302-4P	3.9	FL800X-4P	3.9	NF2002-4P	3.6
FJ302-6P	3.9	FLSWM5X8AY	1.16	NF2002-6P	3.6
FJ304-3P	3.8	FPMH3.5X12X-TX15	1.21	NF2004-2P	3.6
FJ304-4P	3.9	FPMH5X14X-TORX	1.21	NF2004-3C	3.6
FJ304-6P	3.9	L200A8RB	4.16	NF2004-3P	3.5
FJ30X-3P	3.8	MWS3PB	4.19	NF2004-4P	3.6
FJ30X-4P	3.9	NF1001-3P	3.5	NF2004-6P	3.6
FJ30X-6P	3.9	NF1001-3T	3.6	NF200X-2P	3.6
FJ4001-2P	3.9	NF1001-4P	3.6	NF200X-3C	3.6

## Quick product finder

Catalogue number	Page	Catalogue number	Page	Catalogue number	Page
NF200X-4P	3.6	NF600X-6P	3.6	OESAZD48	2.8
NF200X-6P	3.6	NF601-3P	3.5	OESA-ZD54	2.11
NF301-3P	3.5	NF601-3T	3.6	OESAZD55	2.8
NF301-3T	3.6	NF601-4P	3.6	OESA-ZK98	2.11
NF301-4P	3.6	NF601-6P	3.6	OESA-ZL79	2.15
NF301-6P	3.6	NF602-3P	3.5	OESA-ZS36	2.11
NF302-3P	3.5	NF602-3T	3.6	OESA-ZW1	1.18 - 2.12
NF302-3T	3.6	NF602-4P	3.6	OESA-ZW2	1.18 - 1.22 - 2.12
NF302-4P	3.6	NF602-6P	3.6	OESA-ZX125	2.15
NF302-6P	3.6	NF604-3P	3.5	OESA-ZX167	1.17 - 1.21 - 2.12
NF304-3P	3.5	NF604-3T	3.6	OESA-ZX171	2.9
NF304-3T	3.6	NF604-4P	3.6	OESA-ZX196	2.15
NF304-4P	3.6	NF604-6P	3.6	OESAZX1-J4T6	2.15
NF304-6P	3.6	NF60X-3P	3.5	OESAZX1-J6T6	2.15
NF30X-3P	3.5	NF60X-3T	3.6	OESAZX1-L8T6	2.15
NF30X-3T	3.6	NF60X-4P	3.6	OESAZX1-S10	2.19
NF30X-4P	3.6	NF60X-6P	3.6	OESAZX1-S10/4	2.19
NF30X-6P	3.6	NF631-3P	3.4	OESAZX1-S11	2.19
NF321-3P	3.4	NF631-3S	3.4	OESAZX1-S11/4	2.19
NF321-3S	3.4	NF632-3P	3.4	OESAZX1-S2	2.19
NF322-3P	3.4	NF632-3S	3.4	OESAZX1-S2/4	2.19
NF322-3S	3.4	NF634-3P	3.4	OESAZX1-S3	2.19
NF324-3P	3.4	NF63X-3P	3.4	OESAZX1-S3/4	2.19
NF32X-3P	3.4	NF8001-2P	3.6	OESAZX1-S4	2.19
NF4001-2P	3.6	NF8001-3P	3.5	OESAZX1-S4/4	2.19
NF4001-3C	3.6	NF8001-3T	3.6	OESAZX1-S5	2.19
NF4001-3P	3.5	NF8001-4P	3.6	OESAZX1-S5/4	2.19
NF4001-4P	3.6	NF8001-6P	3.6	OESAZX1-S6	2.19
NF4001-6P	3.6	NF8002-2P	3.6	OESAZX1-S6/4	2.19
NF4002-2P	3.6	NF8002-3P	3.5	OESAZX1-S7	2.19
NF4002-3C	3.6	NF8002-3T	3.6	OESAZX1-S7/4	2.19
NF4002-3P	3.5	NF8002-4P	3.6	OESAZX1-S8	2.19
NF4002-4P	3.6	NF8002-6P	3.6	OESAZX1-S8/4	2.19
NF4002-6P	3.6	NF8004-2P	3.6	OESAZX1-S9	2.19
NF4004-2P	3.6	NF8004-3P	3.5	OESAZX1-S9/4	2.19
NF4004-3C	3.6	NF8004-3T	3.6	OESA-ZX204	2.15
NF4004-3P	3.5	NF8004-4P	3.6	OESAZX2-S2	2.19
NF4004-4P	3.6	NF8004-6P	3.6	OESAZX2-S2/4	2.19
NF4004-6P	3.6	NF800X-2P	3.6	OESAZX2-S3	2.19
NF400X-2P	3.6	NF800X-3T	3.6	OESAZX2-S3/4	2.19
NF400X-3C	3.6	NF800X-4P	3.6	OESAZX2-S4	2.19
NF400X-4P	3.6	NF800X-6P	3.6	OESAZX2-S4/4	2.19
NF400X-6P	3.6	OA1G01	1.14 - 3.4	OESAZX2-S5	2.19
NF451-3P	3.4	OA1G01AU	1.14	OESAZX2-S5/4	2.19
NF451-3S	3.4	OA1G10	1.14 - 1.21 - 2.9 - 2.11 - 2.15 - 3.4	OESAZX2-S6	2.19
NF452-3P	3.4	OA1G10AU	1.14	OESAZX2-S6/4	2.19
NF452-3S	3.4	OA2G11	1.14	OESA-ZX88	2.15
NF454-3P	3.4	OA3G01	1.14 - 1.21 - 2.9 - 2.11 - 2.15	OESC250K03	1.26
NF45X-3P	3.4	OA4B1C	2.9	OESC250K04	1.26
NF6001-2P	3.6	OA7G10	1.14	OESC250K04N2	1.26
NF6001-3C	3.6	OAZX1	1.14	OESC400K04N2	1.26
NF6001-3P	3.5	OBEA01	1.14	OESC500K03	1.26
NF6001-4P	3.6	OBEA-01AU	1.14	OESC500K04	1.26
NF6001-6P	3.6	OBEA10	1.14	OETL-NF1600	1.9 - 1.19
NF6002-2P	3.6	OBEA-10AU	1.14	OETL-NF1600-2	1.19
NF6002-3C	3.6	OEA28	1.21 - 2.11 - 2.15	OETL-NF1600-4	1.19
NF6002-3P	3.5	OES200J3-S	2.17	OETL-NF1600P	1.8 - 1.9
NF6002-4P	3.6	OES200R03	2.19	OETL-NF2000	1.9 - 1.19
NF6002-6P	3.6	OES200R04	2.19	OETL-NF2000-2	1.19
NF6004-2P	3.6	OES400J3-S	2.17	OETL-NF2000-4	1.19
NF6004-3C	3.6	OES400R03	2.19	OETL-NF2000P	1.8 - 1.9
NF6004-3P	3.5	OES400R04	2.19	OETL-NF200A-S	1.24
NF6004-4P	3.6	OES600R03	2.19	OETL-NF400-S	1.24
NF6004-6P	3.6	OES600R04	2.19	OETL-NF600A-S	1.24
NF600X-2P	3.6	OES800R03	2.19	OETL-ZK19	1.17 - 2.12
NF600X-3C	3.6	OES800R04	2.19	OETL-ZW12	1.22 - 2.16
NF600X-4P	3.6	OESAZD28	2.8	OETL-ZW13	1.22 - 2.16

## Quick product finder

Catalogue number	Page	Catalogue number	Page	Catalogue number	Page
OETL-ZW15	1.22 - 2.16	OHY65L6E011	1.12	OL200A2RB	4.16
OETL-ZW16	1.17 - 2.12	OHY80J6	1.12 - 1.20 - 1.24 - 2.10 - 2.17	OL200A3RB	4.16
OETL-ZW5	1.23 - 2.15	OHY80L6	1.12 - 1.20 - 2.10	OL200A4RB	4.16
OETL-ZW9	1.22 - 2.16	OHYS2AJ	1.12	OL200A6RB	4.16
OETL-ZX119	2.15	OHYS2AJE011	1.12	OL200P012RB	4.26
OETL-ZX58	1.17	OHYS2PJ	1.12	OL200PW36RB	4.21
OETL-ZX74	1.24 - 2.17	OHYS2RJ	1.12	OL200PW48RB	4.21
OETL-ZX95	1.17 - 1.21 - 2.12 - 2.15	OHYS3AH1	1.12	OL200SDRB	4.26
OEZKL1	1.21	OHYS3PH	1.12	OL200SO21RB	4.22
OEZKL2	1.21	OHYS3RH	1.12	OL200SO31RB	4.22
OEZNP1	1.14	OHYS7	1.16	OL200U1RB	4.18
OFM240	2.11 - 2.15	OHZX10	1.17 - 1.20 - 2.10	OL200U2RB	4.18
OFM600	2.11 - 2.15	OHZX11	1.17	OL200U3RB	4.18
OFMZX2	2.11 - 2.15	OHZX12	1.17	OL200U4RB	4.18
OFMZX4	2.15	OHZX13	1.17	OL200UC3RB	4.20
OFS240	2.11	OHZX3	1.21	OL200UC4RB	4.20
OFS600	2.11	OHZX5	1.16	OL200WS1RB	4.19
OHB13	1.16	OHZX6	1.17	OL200WS2RB	4.19
OHB145J12	1.9 - 1.20 - 1.24 - 2.7 - 2.14 - 2.17	OL125A1RB	4.16	OL200WS36RB	4.21
OHB145L12	1.20 - 2.14	OL125A2RB	4.16	OL200WS3RB	4.19
OHB175J12	1.20 - 2.14	OL125A3RB	4.16	OL200WS48RB	4.21
OHB175L12	1.20 - 2.14	OL125A4RB	4.16	OL200WS4RB	4.19
OHB2/1	1.16	OL125A6RB	4.16	OL406PBS12326	4.26
OHB200J12	1.9 - 1.20	OL125A8RB	4.16	OL40A1KBA	4.16
OHB3RH	1.12	OL125P012RB	4.26	OL40A1PBA	4.16
OHB4	2.10	OL125PW36RB	4.21	OL40A2KBA	4.16
OHB45J6	1.12	OL125PW48RB	4.21	OL40A2PBA	4.16
OHB65J6	1.9 - 1.12 - 1.24 - 2.7 - 2.8 - 2.10 - 2.17	OL125SDRB	4.26	OL40A3KBA	4.16
OHB65J6E011	1.12	OL125SO21RB	4.22	OL40A3PBA	4.16
OHB65L6	1.12 - 2.8	OL125SO31RB	4.22	OL40A4KBA	4.16
OHB65L6E011	1.12	OL125U1RB	4.18	OL40A4PBA	4.16
OHB80J6	1.9 - 1.12 - 1.20 - 1.24 - 2.7 - 2.10 - 2.17	OL125U2RB	4.18	OL40A6PBA	4.16
OHB80J8	1.24	OL125U3RB	4.18	OL40A8PBA	4.16
OHB80L6	1.12 - 1.20 - 2.10	OL125U4RB	4.18	OL40AU31PB	4.29
OHB95J12	1.9	OL125UC3RB	4.20	OL40AU32PB	4.29
OHBS11	1.16	OL125UC4Rb	4.20	OL40P12PB	4.26
OHBS12	1.16	OL125WS1RB	4.19	OL40PW36PB	4.21
OHBS2AJ	1.9 - 1.12	OL125WS2RB	4.19	OL40PW48PB	4.21
OHBS2AJE011	1.12	OL125WS36RB	4.21	OL40SDPB	4.26
OHBS2AJEH	1.12	OL125WS3RB	4.19	OL40SO101PB	4.25
OHBS2PJ	1.9 - 1.12	OL125WS48RB	4.21	OL40SO111PB	4.25
OHBS2PJEH	1.12	OL125WS4RB	4.19	OL40SO21PB	4.22
OHBS2RJ	1.9 - 1.12	OL160A1RB	4.16	OL40SO22PB	4.22
OHBS3AH1	1.12	OL160A2RB	4.16	OL40SO23PB	4.22
OHBS3PH	1.12	OL160A3RB	4.16	OL40SO24PB	4.22
OHBS5	2.8	OL160A4RB	4.16	OL40SO26PB	4.22
OHBS7	1.16	OL160A6RB	4.16	OL40SO31PB	4.22
OHF1C12	1.25 - 2.18	OL160A8RB	4.16	OL40SO32PB	4.22
OHF1C4	1.25 - 2.18	OL160P012RB	4.26	OL40SO33PB	4.22
OHG145J12	1.20 - 2.14	OL160PW36RB	4.21	OL40SO34PB	4.22
OHG65J6	1.12 - 2.8 - 2.10	OL160PW48RB	4.21	OL40SO35PB	4.22
OHG80J6	1.12 - 1.20	OL160SDRB	4.26	OL40SO41PB	4.23
OHGS2AJ	1.12	OL160SO21RB	4.22	OL40SO42PB	4.23
OHM125L12	1.20 - 2.14	OL160SO31RB	4.22	OL40SO43PB	4.23
OHM175L12	1.20 - 2.14	OL160U1RB	4.18	OL40SO51PB	4.23
OHM275L12	1.20 - 2.14	OL160U2RB	4.18	OL40SO52PB	4.23
OHM65L6	1.12 - 1.20 - 2.8 - 2.10	OL160U3RB	4.18	OL40SO61PB	4.24
OHRS2	1.16	OL160U4RB	4.18	OL40SO62PB	4.24
OHY125J12	2.14	OL160UC3RB	4.20	OL40SO63PB	4.24
OHY145J12	1.20 - 1.24 - 2.14 - 2.17	OL160UC4RB	4.20	OL40SO71PB	4.24
OHY145L12	1.20 - 2.14	OL160WS1RB	4.19	OL40SO81PB	4.24
OHY175J12	1.20 - 2.14	OL160WS2RB	4.19	OL40SO91PB	4.25
OHY175L12	1.20 - 2.14	OL160WS36RB	4.21	OL40ST101PB	4.25
OHY45J6	1.12	OL160WS3RB	4.19	OL40ST111PB	4.25
OHY65J6	1.12 - 1.24 - 2.8 - 2.10 - 2.17	OL160WS48RB	4.21	OL40ST121PB	4.25
OHY65J6E011	1.12	OL160WS4RB	4.19	OL40ST301PB	4.26
OHY65L6	1.12 - 2.8	OL200A1RB	4.16	OL40ST31PB	4.23

## Quick product finder

Catalogue number	Page	Catalogue number	Page	Catalogue number	Page
OL40ST32PB	4.23	OL80SO31RB	4.22	OMA6PBA	4.16
OL40ST33PB	4.23	OL80U1RB	4.18	OMAU31PB	4.29
OL40ST34PB	4.23	OL80U2RB	4.18	OMF101	4.32
OL40ST36PB	4.23	OL80U3RB	4.18	OMFB72	4.32
OL40ST38PB	4.23	OL80U4RB	4.18	OMFG72	4.32
OL40ST41PB	4.23	OL80UC3RB	4.20	OMFY101	4.32
OL40ST42PB	4.23	OL80UC4RB	4.20	OMK95	4.33
OL40ST43PB	4.23	OL80W2RB	4.26	OMNX80	4.33
OL40ST51PB	4.23	OL80WC1RB	4.20	OMPB1	4.31
OL40ST52PB	4.23	OL80WC2RB	4.20	OMPG1	4.31
OL40ST61PB	4.24	OL80WC3RB	4.20	OMPR1	4.31
OL40ST62PB	4.24	OL80WC4RB	4.20	OMPRY1	4.31
OL40ST63PB	4.24	OL80WS1RB	4.19	OMSA2PB	4.27
OL40ST71PB	4.24	OL80WS2RB	4.19	OMSE158PB	4.27
OL40ST81PB	4.24	OL80WS36RB	4.21	OMSE2PB	4.27
OL40ST91PB	4.25	OL80WS3RB	4.19	OMSEA10PB	4.27
OL40U1KB	4.18	OL80WS48RB	4.21	OMSO21PB	4.22
OL40U1PB	4.18	OL80WS4RB	4.19	OMSO22PB	4.22
OL40U2KB	4.18	OLF130	4.32	OMSO23PB	4.22
OL40U2PB	4.18	OLF64	4.32	OMSO24PB	4.22
OL40U3KB	4.18	OLF90	4.32	OMSO31PB	4.22
OL40U3PB	4.18	OLFB64	4.32	OMSO32PB	4.22
OL40U4KB	4.18	OLFC130	4.32	OMSO33PB	4.22
OL40U4PB	4.18	OLFC64	4.32	OMSO34PB	4.22
OL40U5PB	4.18	OLFC90	4.32	OMSO41PB	4.23
OL40U6PB	4.18	OLFG64	4.32	OMSO42PB	4.23
OL40UC3PB	4.20	OLFY130	4.32	OMSO43PB	4.23
OL40UC4PB	4.20	OLFY64	4.32	OMSO51PB	4.23
OL40UR139PB	4.27	OLFY90	4.32	OMSO52PB	4.23
OL40URR1PB	4.18	OLR2B	4.31	OMST31PB	4.22
OL40URR2PB	4.18	OLR2G	4.31	OMST32PB	4.22
OL40URR3PB	4.18	OLR2R	4.31	OMST33PB	4.22
OL40URR5PB	4.18	OLR3B	4.31	OMST34PB	4.22
OL40V30PB	4.28	OLR3G	4.31	OMST41PB	4.23
OL40V32PB	4.28	OLR3R	4.31	OMST42PB	4.23
OL40V3PB	4.28	OLZ12	4.32	OMST43PB	4.23
OL40VN30PB	4.28	OLZ1601L2	4.33	OMST51PB	4.23
OL40VN3PB	4.28	OLZ1601L4	4.33	OMST52PB	4.23
OL40W2PB	4.26	OLZ1601L6	4.33	OMU1KB	4.18
OL40W3PB	4.26	OLZ2RB	4.31	OMU1PB	4.18
OL40WC1PB	4.20	OLZ2RR	4.31	OMU2PB	4.18
OL40WC2PB	4.20	OLZ332RB	4.31	OMU3KB	4.18
OL40WC3PB	4.20	OLZ332RRY	4.31	OMU3PB	4.18
OL40WC4PB	4.20	OLZ3DB	4.31	OMU4PB	4.18
OL40WS10PB	4.19	OLZ3DR	4.31	OMURR1PB	4.18
OL40WS1PB	4.19	OLZ3RB	4.31	OMURR3PB	4.18
OL40WS2PB	4.19	OLZ3RR	4.31	OMV30PB	4.28
OL40WS36PB	4.21	OLZ401L2	4.33	OMV32PB	4.28
OL40WS3PB	4.19	OLZ401L4	4.33	OMV3PB	4.28
OL40WS48PB	4.21	OLZ401L6	4.33	OMVN30PB	4.28
OL40WS4PB	4.19	OLZ652	4.32	OMVN3PB	4.28
OL40WS5PB	4.19	OLZ653	4.32	OMWC1PB	4.20
OL40WS6PB	4.19	OMA01KBA	4.17	OMWC2PB	4.20
OL40WS7PB	4.19	OMA01PBA	4.17	OMWC3PB	4.20
OL40WS8PB	4.19	OMA02PBA	4.17	OMWC4PB	4.20
OL40WS9PB	4.19	OMA03KBA	4.17	OMWS1PB	4.19
OL80A1RB	4.16	OMA03PBA	4.17	OMWS2PB	4.19
OL80A2RB	4.16	OMA04PBA	4.17	OMWS4PB	4.19
OL80A3RB	4.16	OMA05PBA	4.17	OMX99	4.32
OL80A4RB	4.16	OMA06PBA	4.17	OMXB1	4.31
OL80A6RB	4.16	OMA1KBA	4.16	OMXNB1	4.31
OL80A8RB	4.16	OMA1PBA	4.16	ON6PBS5487	4.26
OL80PO12RB	4.26	OMA2PBA	4.16	ONA01KBA	4.17
OL80PW36RB	4.21	OMA3KBA	4.16	ONA01MA	4.17
OL80PW48RB	4.21	OMA3PBA	4.16	ONA01PBA	4.17
OL80SDRB	4.26	OMA4PBA	4.16	ONA02MA	4.17
OL80SO21RB	4.22	OMA5PBA	4.16	ONA02PBA	4.17

## Quick product finder

Catalogue number	Page	Catalogue number	Page	Catalogue number	Page
ONA03KBA	4.17	ONSE158PB	4.27	ONU6PB	4.18
ONA03MA	4.17	ONSE2PB	4.27	ONUC3PB	4.20
ONA03PBA	4.17	ONSEA10M	4.27	ONUC4PB	4.20
ONA04PBA	4.17	ONSEA10PB	4.27	ONUR139M	4.27
ONA05PBA	4.17	ONSEA1PB	4.27	ONUR139PB	4.27
ONA06MA	4.17	ONSO101PB	4.25	ONURR1M	4.18
ONA06PBA	4.17	ONSO111PB	4.25	ONURR1PB	4.18
ONA1EKB	4.54	ONSO21M	4.22	ONURR2PB	4.18
ONA1EPB	4.54	ONSO21PB	4.22	ONURR3PB	4.18
ONA1EZB	4.54	ONSO22M	4.22	ONURR5PB	4.18
ONA1KBA	4.16	ONSO22PB	4.22	ONV30M	4.28
ONA1MA	4.16	ONSO23PB	4.22	ONV30PB	4.28
ONA1PBA	4.16	ONSO24PB	4.22	ONV32PB	4.28
ONA2EPB	4.54	ONSO26PB	4.22	ONV3M	4.28
ONA2EZB	4.54	ONSO31M	4.22	ONV3PB	4.28
ONA2KBA	4.16	ONSO31PB	4.22	ONVA21PB	4.29
ONA2MA	4.16	ONSO32PB	4.22	ONVN30M	4.28
ONA2PBA	4.16	ONSO33PB	4.22	ONVN30PB	4.28
ONA3EKB	4.54	ONSO34PB	4.22	ONVN3M	4.28
ONA3EPB	4.54	ONSO35PB	4.22	ONVN3PB	4.28
ONA3EZB	4.54	ONSO41PB	4.23	ONW2PB	4.26
ONA3KBA	4.16	ONSO42PB	4.23	ONW3EPB	4.54
ONA3MA	4.16	ONSO43PB	4.23	ONW3PB	4.26
ONA3PBA	4.16	ONSO51M	4.23	ONWC1PB	4.20
ONA4EPB	4.54	ONSO51PB	4.23	ONWC2PB	4.20
ONA4EZB	4.54	ONSO52PB	4.23	ONWC3PB	4.20
ONA4PBA	4.16	ONSO61PB	4.24	ONWC4PB	4.20
ONA5PBA	4.16	ONSO62PB	4.24	ONWS10PB	4.19
ONA6MA	4.16	ONSO63PB	4.24	ONWS1M	4.19
ONA6PBA	4.16	ONSO71PB	4.24	ONWS1PB	4.19
ONA8PBA	4.16	ONSO81PB	4.24	ONWS2M	4.19
ONAU31M	4.29	ONSO91PB	4.25	ONWS2PB	4.19
ONAU31PB	4.29	ONST101PB	4.25	ONWS36PB	4.21
ONAU32PB	4.29	ONST111PB	4.25	ONWS3M	4.19
ONAU32PB	4.29	ONST121PB	4.25	ONWS3PB	4.19
ONAV12PB	4.29	ONST301M	4.26	ONWS48PB	4.21
ONBC0110PB	4.30	ONST301PB	4.26	ONWS4M	4.19
ONBC0112PB	4.30	ONST31M	4.22	ONWS4PB	4.19
ONBC070PB	4.30	ONST31PB	4.22	ONWS5PB	4.19
ONBC070PB	4.30	ONST32PB	4.22	ONWS6PB	4.19
ONBC071PB	4.30	ONST33PB	4.22	ONWS7PB	4.19
ONBC071PB	4.30	ONST34PB	4.22	ONWS8PB	4.19
ONBC072PB	4.30	ONST41PB	4.23	ONWS9PB	4.19
ONBC090PB	4.30	ONST42PB	4.23	ONX30	4.33
ONBC091PB	4.30	ONST43PB	4.23	ONX99	4.32
ONBC092PB	4.30	ONST51PB	4.23	ONXB1	4.31
ONF101	4.32	ONST52PB	4.23	ONZ10L2	4.33
ONFB72	4.32	ONST61PB	4.24	ONZ10L4	4.33
ONFC101	4.32	ONST62PB	4.24	ONZ10L6	4.33
ONFG72	4.32	ONST63PB	4.24	ONZ11	4.32
ONFM101	4.32	ONST71PB	4.24	ONZ20B	4.31
ONFY101	4.32	ONST81PB	4.24	ONZ20RY	4.31
ONK95	4.33	ONST91PB	4.25	ONZ331PB	4.31
ONP12PB	4.26	ONU1EPB	4.54	ONZ331PRY	4.31
ONPB1	4.31	ONU1KB	4.18	ONZ45P	4.32
ONPG1	4.31	ONU1M	4.18	ONZ74	4.33
ONPLB1	4.31	ONU1PB	4.18	OS100B12	2.22
ONPLG1	4.31	ONU2EPB	4.54	OS100B22N1	2.22
ONPLR1	4.31	ONU2M	4.18	OS100F12	2.21
ONPLRY1	4.31	ONU2PB	4.18	OS100F22N1	2.21
ONPR1	4.31	ONU3KB	4.18	OS100J02	2.10
ONPRY1	4.31	ONU3M	4.18	OS100J03	2.10
ONPW36PB	4.21	ONU3PB	4.18	OS100J03-FC	2.18
ONPW48PB	4.21	ONU4KB	4.18	OS100J12	2.7 - 2.10
ONSA2PB	4.27	ONU4M	4.18	OS100J12P	2.7
ONSDPB	4.26	ONU4PB	4.18	OS100-J1T6	2.11
ONSE158M	4.27	ONU5PB	4.18	OS100J22F	2.10

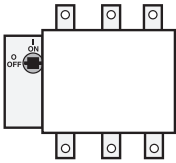

OS100JS30 .....	2.17	OS600J03P .....	2.7	OSS200G1L/3 .....	2.11
OS125B12 .....	2.22	OS600J04 .....	2.14	OSS200G1L/4 .....	2.11
OS125B22N1 .....	2.22	OS600J12 .....	2.14	OSS200G1S/3 .....	2.11
OS125D12 .....	2.20	OS600J30 .....	2.14	OSS200G1S/4 .....	2.11
OS125D22F .....	2.20	OS60J12 .....	2.7 - 2.10	OSV200BK .....	2.10
OS125F12 .....	2.21	OS60J12-FC .....	2.18	OSZ1 .....	2.11
OS125F22N1 .....	2.21	OS60J12P .....	2.7	OSZ2 .....	2.11
OS160B12 .....	2.22	OS60J22F .....	2.10	OSZ4 .....	2.9
OS160B22N1 .....	2.22	OS60JS30 .....	2.17	OT100E3-FC .....	1.25
OS160D12 .....	2.20	OS630B12P .....	2.22	OT100F3 .....	1.9 - 1.11
OS160D22F .....	2.20	OS630B22N2P .....	2.22	OT100F3C .....	1.11 -
OS200B12P .....	2.22	OS630D12P .....	2.20	OT100F3P .....	1.8 - 1.9
OS200B22N2P .....	2.22	OS630D22N2P .....	2.20	OT100F3S .....	1.8 - 1.9
OS200D12P .....	2.20	OS63B12 .....	2.22	OT100F6 .....	1.11
OS200D22N2P .....	2.20	OS63B22N1 .....	2.22	OT100FT3 .....	1.9 - 1.11
OS200J02 .....	2.10	OS63D12 .....	2.20	OT100FT3P .....	1.8 - 1.9
OS200J03 .....	2.7 - 2.10	OS63D22F .....	2.20	OT100FT3S .....	1.8
OS200J03-FC .....	2.18	OS63F12 .....	2.21	OT1200U02 .....	1.19
OS200J03P .....	2.7	OS63F22N1 .....	2.21	OT1200U03 .....	1.9 - 1.19
OS200J04 .....	2.10	OS63X12 .....	2.23	OT1200U03P .....	1.8 - 1.9
OS200J12 .....	2.10	OS63X22F .....	2.23	OT1200U04 .....	1.19
OS200-J2T6 .....	2.11	OS63X22N11 .....	2.23	OT1200U12 .....	1.19
OS200J30 .....	2.10	OS63XS30 .....	2.23	OT160E2 .....	1.11
OS20FB12A1 .....	2.22	OS63XS40F .....	2.23	OT160E3 .....	1.9 - 1.11
OS20FB22A1N1 .....	2.22	OS63XS40N11 .....	2.23	OT160E3-FC .....	1.25
OS250B12P .....	2.22	OS800B12P .....	2.22	OT160E3P .....	1.8 - 1.9
OS250B22N2P .....	2.22	OS800B22N2P .....	2.22	OT160ET3 .....	1.8 - 1.9 - 1.11
OS250D12P .....	2.20	OS800D12P .....	2.20	OT160ET3-2 .....	1.9 - 1.11
OS250D22N2P .....	2.20	OS800D22N2P .....	2.20	OT16F3 .....	1.9 - 1.10
OS25FF1210 .....	2.21	OS800L02 .....	2.14	OT16F3C .....	1.10
OS25FF2210N1 .....	2.21	OS800L03 .....	2.7 - 2.14	OT16F3P .....	1.8 - 1.9
OS30FACC12 .....	2.7 - 2.8	OS800L03P .....	2.7 - 2.14	OT16F3S .....	1.8 - 1.9
OS30FACC12-FC .....	2.18	OS800L04 .....	2.14	OT16F6 .....	1.10
OS30FACC12P .....	2.7	OS800L12 .....	2.14	OT16FT3 .....	1.9 - 1.10
OS30FACC22F .....	2.8	OSC16D301 .....	2.23	OT16FT3S .....	1.8 - 1.9
OS30FACCS30 .....	2.17	OSC16D401 .....	2.23	OT200U02 .....	1.19
OS30FAJ12 .....	2.7 - 2.8	OSC25F310 .....	2.23	OT200U03 .....	1.9 - 1.19
OS30FAJ12-FC .....	2.18	OSC25F410 .....	2.23	OT200U03C .....	1.19
OS30FAJ12P .....	2.7	OSC30ACC3 .....	2.23	OT200U03-FC .....	1.25
OS30FAJ22F .....	2.8	OSC30ACC4 .....	2.23	OT200U03P .....	1.8 - 1.9
OS30FAJS30 .....	2.17	OSC30AJ3 .....	2.23	OT200U04 .....	1.19
OS315B12P .....	2.22	OSC30AJ4 .....	2.23	OT200U04C .....	1.19
OS315B22N2P .....	2.22	OSC32B3A1 .....	2.23	OT200U12 .....	1.19
OS32FB12 .....	2.22	OSC32B3A2 .....	2.23	OT200U30 .....	1.19
OS32FB22N1 .....	2.22	OSC32B3E1 .....	2.23	OT25F3 .....	1.9 - 1.10
OS32FD12 .....	2.20	OSC32B3F1 .....	2.23	OT25F3C .....	1.10
OS32FD22F .....	2.20	OSC32B4A1 .....	2.23	OT25F3P .....	1.8 - 1.9
OS32FF1214 .....	2.21	OSC32B4A2 .....	2.23	OT25F3S .....	1.8 - 1.9
OS32FF2214N1 .....	2.21	OSC32B4E1 .....	2.23	OT25F6 .....	1.10
OS32M12 .....	2.23	OSC32B4F1 .....	2.23	OT25FT3 .....	1.9 - 1.10
OS32M22F .....	2.23	OSC32F314 .....	2.23	OT25FT3S .....	1.8 - 1.9
OS32M22N11 .....	2.23	OSC32F414 .....	2.23	OT30E3-FC .....	1.25
OS32MS30 .....	2.23	OSC35D302 .....	2.23	OT30F3 .....	1.9 - 1.11
OS32MS40F .....	2.23	OSC35D402 .....	2.23	OT30F3C .....	1.11
OS32MS40N11 .....	2.23	OSC50F3 .....	2.23	OT30F3P .....	1.8 - 1.9
OS400B12P .....	2.22	OSC50F4 .....	2.23	OT30F3S .....	1.8 - 1.9
OS400B22N2P .....	2.22	OSC60J3 .....	2.11 - 2.23	OT30F6 .....	1.11
OS400D12P .....	2.20	OSC60J4 .....	2.23	OT30FT3 .....	1.9 - 1.11
OS400D22N2P .....	2.20	OSC63B3 .....	2.23	OT30FT3P .....	1.8 - 1.9
OS400J02 .....	2.14	OSC63B4 .....	2.23	OT30FT3S .....	1.8 - 1.9
OS400J03 .....	2.7 - 2.14	OSC63D3 .....	2.23	OT400U02 .....	1.19
OS400J03P .....	2.7	OSC63D4 .....	2.23	OT400U03 .....	1.9 - 1.19
OS400J04 .....	2.14	OSC63F3 .....	2.23	OT400U03C .....	1.19
OS400J12 .....	2.14	OSC63F4 .....	2.23	OT400U03P .....	1.8 - 1.9
OS400J30 .....	2.14	OSNF100-S .....	1.24	OT400U04 .....	1.19
OS50F12 .....	2.21	OSNF30-S .....	1.24	OT400U04C .....	1.19
OS50F22N1 .....	2.21	OSNF60-S .....	1.24	OT400U12 .....	1.19
OS600J02 .....	2.14	OSS160T1 .....	2.11	OT400U30 .....	1.19
OS600J03 .....	2.7 - 2.14	OSS160T3 .....	2.11	OT40F3 .....	1.9 - 1.10



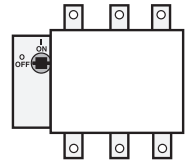

OT40F3C .....	1.10	OTPN80FP .....	1.15	EXP12X535 .....	1.20 - 2.14
OT40F3P .....	1.8 - 1.9	OTPS125FD .....	1.15	EXP12X625 .....	1.20
OT40F3S .....	1.8 - 1.9	OTPS125FP .....	1.15	EXP6X130 .....	1.9 - 1.13
OT40F6 .....	1.10	OTPS160EP .....	1.15	EXP6X150 .....	1.13 - 1.20 - 2.7 - 2.10
OT40FT3 .....	1.9 - 1.10	OTPS40FDN1 .....	1.15	EXP6X170 .....	1.13
OT40FT3S .....	1.8 - 1.9	OTPS40FDN2 .....	1.15	EXP6X210 .....	1.9 - 1.13 - 1.20 - 1.24 - 2.7 - 2.8 - 2.10 - 2.17
OT600U02 .....	1.19	OTPS40FPN1 .....	1.15 - 3.4	EXP6X265 .....	1.13
OT600U03 .....	1.9 - 1.19	OTPS40FPN2 .....	1.15 - 3.4	EXP6X290 .....	1.13 - 1.20 - 2.8 - 2.10
OT600U03C .....	1.19	OTPS60FP .....	1.15	EXP6X360 .....	1.13 - 1.20 - 2.8 - 2.10
OT600U03P .....	1.8 - 1.9	OTPS80FD .....	1.15	EXP6X400 .....	1.13
OT600U04 .....	1.19	OTPS80FP .....	1.15 - 3.4	EXP6X430 .....	1.13 - 1.20 - 2.8 - 2.10
OT600U04C .....	1.19	OTS125T1 .....	1.15	EXP6X500 .....	1.13
OT600U12 .....	1.19	OTS125T3 .....	1.15	EXP6X700 .....	1.13 - 1.20
OT600U30 .....	1.19	OTS1600G1L/3 .....	1.21	EXP8X240 .....	1.24
OT60E3-FC .....	1.25	OTS1600G1S/4 .....	1.21	OXS6X130 .....	1.13
OT60F3 .....	1.9 - 1.11	OTS160T1 .....	1.15	OXS6X180 .....	1.9 - 1.13
OT60F3C .....	1.11	OTS160T3 .....	1.15	OXS6X250 .....	1.13
OT60F3P .....	1.8 - 1.9	OTS250G1L/3 .....	1.21	OXS6X330 .....	1.13
OT60F3S .....	1.8 - 1.9	OTS250G1S/3 .....	1.21	OXS6X455 .....	1.13
OT60F6 .....	1.11	OTS400G1L/3 .....	1.21	OXS6X85 .....	1.13
OT60FT3 .....	1.9 - 1.11	OTS400G1S/3 .....	1.21	OXT20x210 .....	1.17
OT60FT3P .....	1.8 - 1.9	OTS403 .....	2.15	OZXA-1200 .....	1.9 - 1.21
OT60FT3S .....	1.8 - 1.9	OTS40T1 .....	1.15	OZXA-200 .....	1.9 - 1.21 - 2.7 - 2.10 - 2.18
OT63F3 .....	1.9 - 1.10	OTS40T3 .....	1.15	OZXA-206S .....	2.18
OT63F3C .....	1.10	OTS603 .....	2.15	OZXA-206T .....	1.21
OT63F3P .....	1.8 - 1.9	OTS63T1 .....	1.15	OZXA-24 .....	1.24 - 2.7 - 2.10 - 2.17 - 2.18
OT63F3S .....	1.8 - 1.9	OTS63T3 .....	1.15	OZXA-25 .....	1.24 - 2.17
OT63F6 .....	1.10	OTS800G1L/3 .....	1.21	OZXA-26 .....	1.24 - 2.17
OT63FT3 .....	1.9 - 1.10	OTS800G1S/3 .....	1.21	OZXA-27 .....	1.24
OT63FT3S .....	1.8 - 1.9	OTV250EK .....	1.20	OZXA-28 .....	1.21
OT800U02 .....	1.19	OTV400EK .....	1.20	OZXA-33 .....	1.21 - 2.14
OT800U03 .....	1.9 - 1.19	OTV800EK .....	1.20	OZXA-400 .....	1.9 - 1.21 - 2.7 - 2.14
OT800U03P .....	1.8 - 1.9	OTZC13 .....	1.20	OZXA-402 .....	1.21 - 2.14
OT800U04 .....	1.19	OTZC14 .....	1.20	OZXA-406 .....	1.21
OT800U12 .....	1.19	OTZC23 .....	1.20	OZXA-800 .....	1.9 - 1.21 - 2.7 - 2.14
OT800U30 .....	1.19	OTZC24 .....	1.20	OZXK-1 .....	1.21 - 1.26 - 2.15
OT80F3 .....	1.9 - 1.10	OTZC33 .....	1.20	OZXK-2 .....	1.21 - 1.26 - 2.15
OT80F3C .....	1.10	OTZC34 .....	1.20	OZXK-3 .....	1.21 - 1.26 - 2.15
OT80F3P .....	1.8 - 1.9	OTZC43 .....	1.20	VP3G6 .....	4.54
OT80F3S .....	1.8 - 1.9	OTZC44 .....	1.20	YASDA-33 .....	2.14
OT80F6 .....	1.10	OTZS1 .....	1.16	YASDA-34 .....	1.20
OT80FT3 .....	1.9 - 1.10	OTZS2 .....	1.16	YASDA-8 .....	1.9 - 1.20 - 2.14
OT80FT3S .....	1.8 - 1.9	OTZW10 .....	1.18 - 1.22 - 2.12		
OTC36NPT3/4 .....	4.54	OTZW17 .....	1.18		
OTC46M25 .....	4.54	OTZW24 .....	1.18		
OTPD125FP .....	1.15	OTZW25 .....	1.18 - 1.22 - 2.12		
OTPD40FP .....	1.15	OTZW26 .....	1.18 - 1.22 - 2.12		
OTPD60FP .....	1.15	OTZW8 .....	1.18		
OTPD80FD .....	1.15	OWC6DSH1 .....	2.9		
OTPD80FP .....	1.15	OWC6DSH2 .....	2.9		
OTPE125FD .....	1.15	OWM6DS1 .....	2.9		
OTPE125FP .....	1.15	OWM6DS2 .....	2.9		
OTPE160EP .....	1.15	OWP6DS1 .....	2.9		
OTPE40FD .....	1.15	OWP6DS2 .....	2.9		
OTPE40FP .....	1.15	OXC1L108 .....	1.25 - 2.18		
OTPE80FD .....	1.15	OXC1L36 .....	1.25 - 2.18		
OTPE80FP .....	1.15	OXC1L48 .....	1.25 - 2.18		
OTPL125FD .....	1.15	OXC1L60 .....	1.25 - 2.18		
OTPL125FP .....	1.15	OXC1L72 .....	1.25 - 2.18		
OTPL40FD .....	1.15	OXC1L84 .....	1.25 - 2.18		
OTPL40FP .....	1.15 - 3.4	OXC1L96 .....	1.25 - 2.18		
OTPL80FD .....	1.15	OXN250 .....	1.21 - 2.11		
OTPL80FP .....	1.15 - 3.4	OXN400 .....	1.21		
OTPN125FD .....	1.15	OXN600 .....	1.21		
OTPN125FP .....	1.15	EXP12X250 .....	2.14		
OTPN160EP .....	1.15	EXP12X280 .....	1.9 - 1.20 - 2.7 - 2.14		
OTPN40FD .....	1.15	EXP12X325 .....	1.9 - 1.20 - 1.24 - 2.14 - 2.17		
OTPN40FP .....	1.15	EXP12X395 .....	1.20 - 2.14		
OTPN80FD .....	1.15	EXP12X465 .....	1.20 - 2.14		



# SwitchLine Non-fusible Disconnect switches



## SwitchLine

Non-fusible disconnect switches

Compact, Heavy duty

16A – 2000A, 600V

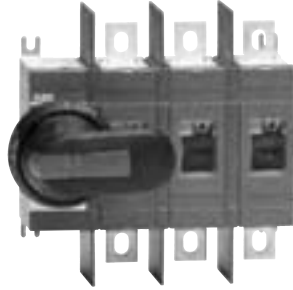

OT200U

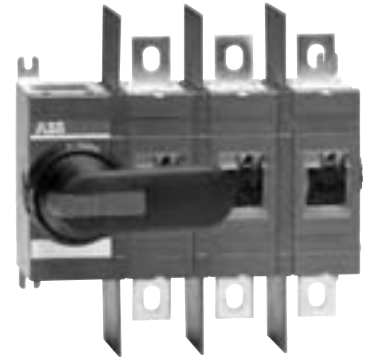

OT400U

ABB SwitchLine includes 16 different amperage sizes from 16A to 2000A. The basic construction provides flexibility, safety, and high performance in an extremely compact size. ABB SwitchLine is a perfect choice for all switching applications from industrial motor control to construction safety switches.

### Index

Overview .....	1.2 – 1.3
General information.....	1.4 – 1.7
<b>Non-fusible disconnect switches for North America and the world: CSA, UL, IEC, CE</b>	
Complete Switches .....	1.8
Individual components:	
16A – 125A DIN rail and door mounted switches .....	1.10
200A – 2000A switches .....	1.19
Technical information .....	1.28
Auxiliary contact timing diagrams .....	1.34
Approximate dimensions .....	1.36



# Overview

## Non-fusible disconnect switches

### OT16F3 – OT100F3



OT16F3 OT25F3 OT40F3



OT63F3 OT80F3



OT30F3 OT60F3 OT100F3

Catalog number	3 pole	OT16F3	OT25F3	OT40F3	OT63F3	OT80F3	OT30F3	OT60F3	OT100F3
<b>General purpose amp rating</b>	<b>A</b>	<b>16</b>	<b>25</b>	<b>40</b>	<b>60</b>	<b>80</b>	<b>30</b>	<b>60</b>	<b>100</b>
Catalog reference	Page #	1.10	1.10	1.10	1.10	1.10	1.11	1.11	1.11
Approvals <sup>①</sup>									
	2 pole	—	—	—	—	—	—	—	—
	3 pole	CSA C22.2 No.14	CSA C22.2 No.14	CSA C22.2 No.14	CSA C22.2 No.14	CSA C22.2 No.14	CSA C22.2 No.4	CSA C22.2 No.4	CSA C22.2 No.4
	4 pole	CSA C22.2 No.14	CSA C22.2 No.14	CSA C22.2 No.14	CSA C22.2 No.14	CSA C22.2 No.14	CSA C22.2 No.4	CSA C22.2 No.4	CSA C22.2 No.4
<b>Technical ratings</b>									
<b>CSA,UL<sup>②</sup></b>									
Max operating voltage	V	600	600	600	600	600	600	600	600
Max horsepower rating									
Three phase									
	208V HP	3	7.5	10	15	20	10	20	25
	240V HP	5	7.5	10	15	20	10	20	30
	480V HP	10	15	20	30	40	20	40	50
	600V HP	10	20	25	30	40	30	40	50
Single phase									
	120V HP	1	1.5	2	2	2	2	3	5
	240V HP	2	3	5	7.5	10	5	7.5	15
<b>Technical ratings</b>									
<b>IEC<sup>③</sup></b>									
Rated insulation and operational voltage, AC20 and DC20 <sup>④</sup>	V	750	750	750	750	750	750	750	750
Rated thermal current, I <sub>th</sub>									
AC 20/DC 20 open	A	25	32	40	63	80	40	63	115
AC 20/DC 20 enclosed	A	25	32	40	63	80	40	63	115
AC 21A ≤ 500V	A	16	25	40	63	80	40	63	100
690V	A	16	25	40	63	80	40	63	100
Rated operational power AC23									
400/415V	kW	7.5	9	11	22	37	15	18.5	37
690V	kW	7.5	9	11	15	18.5	15	15	37
<b>Physical characteristics</b>									
Weight <sup>④</sup> 3 pole	Kg	0.11	0.11	0.11	0.27	0.27	0.36	0.36	0.36
Dimension 3 pole									
	H mm	68	68	68	91	91	100	100	100
	W mm	35	35	35	53	53	70	70	70
	D mm	56	56	56	72	72	75	75	75
<b>Accessories</b>									
Terminal lug kit		Integral	Integral	Integral	Integral	Integral	Integral	Integral	Integral
Terminal shroud		•	•	•	•	•	•	•	•
Auxiliary contact		•	•	•	•	•	•	•	•
Handle CSA/UL/NEMA type									
Type 1, 3R, 12		•	•	•	•	•	•	•	•
Type 1, 3R, 4, 4X, 12		•	•	•	•	•	•	•	•
Handle type									
Selector		•	•	•	•	•	•	•	•
Pistol		•	•	•	•	•	•	•	•
Conversion kits									
6 pole		•	•	•	•	•	•	•	•
Transfer		•	•	•	•	•	•	•	•
Bypass		•	•	•	•	•	•	•	•
Mechanical interlock		•	•	•	•	•	•	•	•
Electrical interlock		—	—	—	—	—	—	—	—

• = Available  
— = Not available

**CSA approved, UL listed, IEC rated, CE marked**

① CSA 22.2 No.4 (UL98) —CSA File #LR58077, UL File # E101914, CSA 22.2 No. 14 (UL508) —CSA File #LR58247, UL File # E63822

② For complete technical information please see page 1.28 – 1.35.

③ 1000V, IEC 408.

④ Switch only

# Overview

## Non-fusible disconnect switches

### OT160E3 – OETL-NF2000

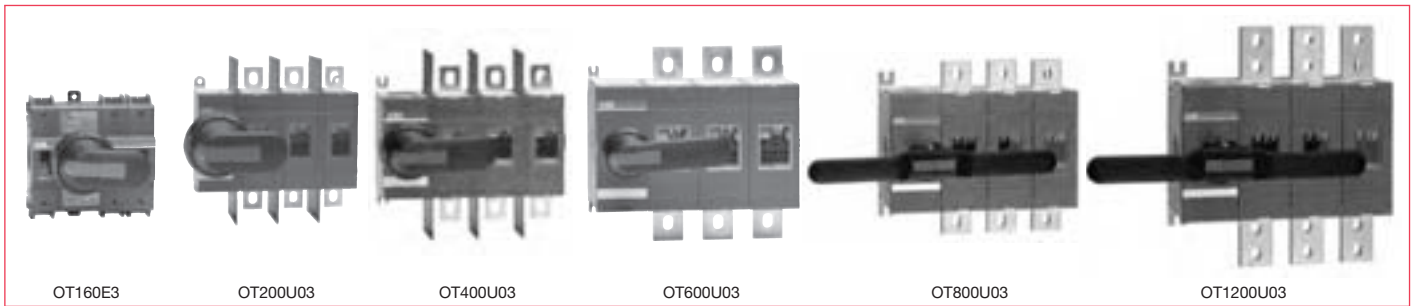

Catalog number	3 pole	OT160E3	OT200U03	OT400U03	OT600U03	OT800U03	OT1200U03	OETL-NF1600	OETL-NF2000	
<b>General purpose amp rating</b>	<b>A</b>	<b>125</b>	<b>200</b>	<b>400</b>	<b>600</b>	<b>800</b>	<b>1200</b>	<b>1600</b>	<b>2000</b>	
Catalog reference	Page #	1.11	1.19	1.19	1.19	1.19	1.19	1.19	1.19	
<b>Approvals<sup>①</sup></b>	2 pole 3 pole 4 pole	CSA C22.2 No.4 CSA C22.2 No.4 CSA C22.2 No.4	CSA C22.2 No.4 CSA C22.2 No.4 CSA C22.2 No.4	CSA C22.2 No.4 CSA C22.2 No.4 CSA C22.2 No.4	CSA C22.2 No.4 CSA C22.2 No.4 CSA C22.2 No.4	CSA C22.2 No.4 CSA C22.2 No.4 CSA C22.2 No.4	CSA C22.2 No.4 CSA C22.2 No.4 CSA C22.2 No.4	CSA C22.2 No.4 CSA C22.2 No.4 IEC	CSA C22.2 No.4 CSA C22.2 No.4 IEC	
<b>Technical ratings</b> <b>CSA, UL<sup>②</sup></b>										
Max operating voltage	V	600	600	600	600	600	600	600	480	
Max horsepower rating										
Three phase										
200 – 208V	HP	30	60	100	150	200	—	—	—	
240V	HP	40	75	125	200	250	—	—	—	
480V	HP	75	150	250	450	500	—	—	—	
600V	HP	100	200	350	500	500	—	—	—	
Single phase										
120V	HP	7.5	—	—	—	—	—	—	—	
240V	HP	20	—	—	—	—	—	—	—	
<b>Technical ratings</b> <b>IEC<sup>③</sup></b>										
Rated insulation and operational voltage. AC20 and DC20 <sup>④</sup>	V	750	1000	1000	1000	1000	1000	1000	1000	
Rated thermal current, I <sub>th</sub>										
AC 20/DC 20 open	A	200	250	400	800	1000	1600	2500	2500	
AC 20/DC 20 enclosed	A	160	250	400	800	1000	1600	2300	2300	
AC 21A 500V	A	160	250	400	800	1000	1600	2500	2500	
AC 21A 690V	A	160	250	400	800	1000	1600	2500	2500	
Rated operational power AC23										
400/415V	kW	75	140	220	400	450	560	400	400	
690V	kW	75	240	390	800	800	800	—	—	
<b>Physical characteristics</b>										
Weight <sup>⑤</sup>	3 pole	Kg	1.1	1.2	2.2	5.2	15.2	15.2	37	37
Dimension	3 pole	H mm W mm D mm	127 126 74	170 170 84	220 221 105	250 266 139	372 334 141	372 334 141	636 468 271	636 468 271
<b>Accessories</b>										
Terminal lug kit		Integral	OZXA-200	OZXA-400	OZXA-800	OZXA-1200	OZXA-1200	DSK8TL	DSK8TM	
Terminal shroud		•	•	•	•	•	•	—	—	
Auxiliary contact		•	•	•	•	•	•	•	•	
Handle CSA/UL/NEMA type										
Type 1, 3R, 12		•	•	•	•	•	•	•	•	
Type 1, 3R, 4, 4X, 12		•	•	•	•	•	•	•	•	
Handle type										
Selector		—	—	—	—	—	—	—	—	
Pistol		•	•	•	•	•	•	•	•	
Conversion kits										
6 pole		•	•	•	•	•	•	—	—	
Transfer		•	•	•	•	•	•	—	—	
Bypass		•	•	•	•	•	•	—	—	
Mechanical interlock		•	•	•	•	•	•	•	•	
Electrical interlock		—	•	•	•	•	•	•	•	

• = Available  
— = Not available

**CSA approved, UL listed, IEC rated, CE marked**

① CSA 22.2 No.4 (UL98) —CSA File #LR58077, UL File # E101914 , CSA 22.2 No. 14 (UL508) —CSA File #LR58247, UL File # E63822

② For complete technical information please see page 1.28 – 1.35.

③ 1000V, IEC 408.

④ Switch only



# Enhanced range of non-fusible disconnect switches

From 16 to 2000 A, 600 V

The non-fusible disconnect switches are suitable for diverse applications, in motor control centers, in switchboards and as main switches in various equipments and machines. From single to 8-poles front operated switches with pistol handle or direct mounted handle. For installation in enclosures, side operated switches and combination switches for change-over, bypass, reversing etc.

- Mountable on DIN rails or base plates and on the door, both by snap-on and screw fitting
- Snap-on mounting of accessories

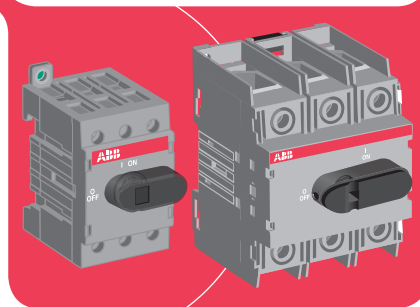
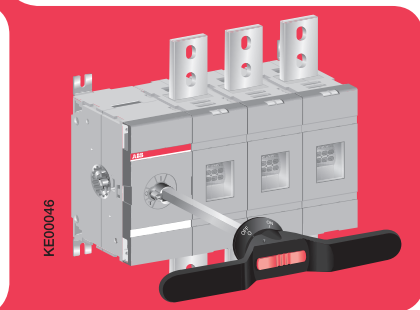
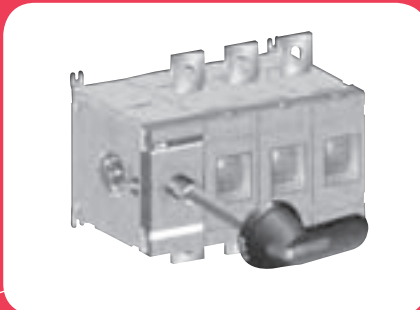
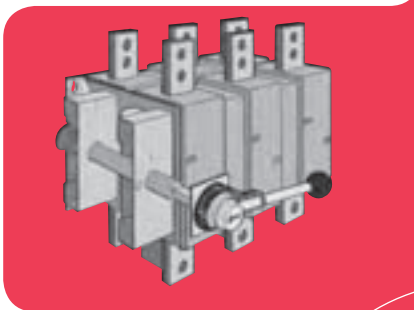
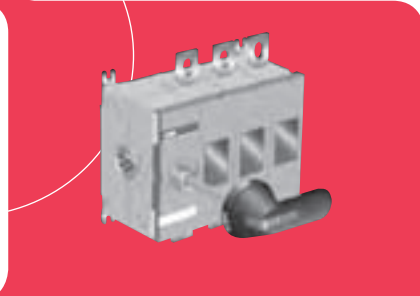
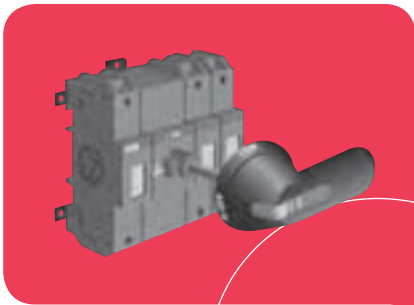

# The most compact disconnect (isolation) solution

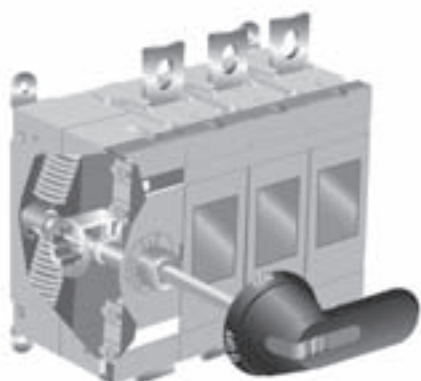

Optimally designed, the OT disconnect switch offers an advanced and compact solution, providing you with added value.

- The new double-sided spring construction in combination with fewer components made an innovative and compact design of the operation mechanism possible.
- The uniquely short current path enabled a small-sized contact construction.

## High performance despite the small size

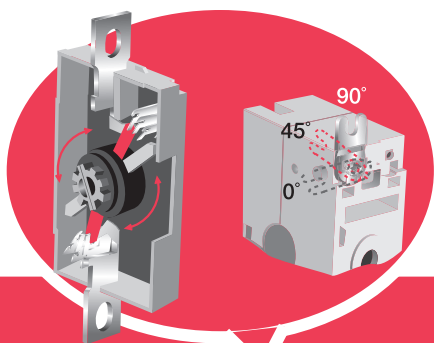

The powerful new construction, with its quick-make and quick-break operation features and two contact points instead of one, adds value to and enhances the performance of the disconnect switches.

- The OT range offers you improved power ratings, the highest on the market. Full  $I_{th}$  ratings can be used both in open air and in enclosures, without having to derate or enlarge the box.
- User-friendly and flexible, the OT disconnect switch provides you with full horse power ratings for all the voltages, even up to 600 V.

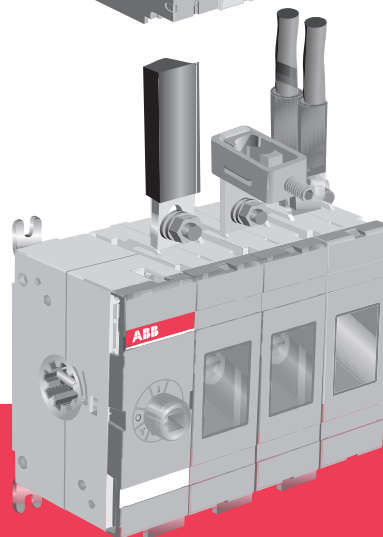
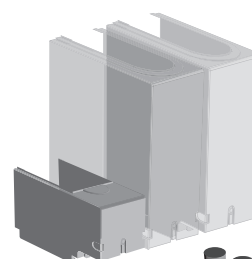

The OT disconnect switch is easy to use and a snap to install according to your choice: horizontally or vertically - even in the ceiling! The adjustable mounting feet allow both top and side mounting of the switch.

ABB's disconnect switch range meets disconnect and isolation requirements more effectively than ever, maximizing the benefits and optimizing your use of assets.

OT16F...OT100F

- 1 Disconnect switch
- 2 Extended shaft
- 3 Terminal clamp
- 4 Fourth pole, N-and PE-terminals
- 5 Auxiliary contact
- 6 Terminal shroud
- 7 Shaft alignment ring
- 8 Legend plate
- 9 Selector type handle
- 10 Handle knob
- 11 Pistol type handle
- 12 Conversion kit
- 13 Labelling accessories
- 14 Cam attachment for interlocking

OT16FT...OT100FT

- 1 Disconnect switch
- 2 Terminal clamp
- 3 Fourth pole, N-and PE-terminals
- 4 Auxiliary contact
- 5 Terminal shroud
- 6 Legend plate
- 7 Selector type handle
- 8 Pistol type handle

502066A



OT160

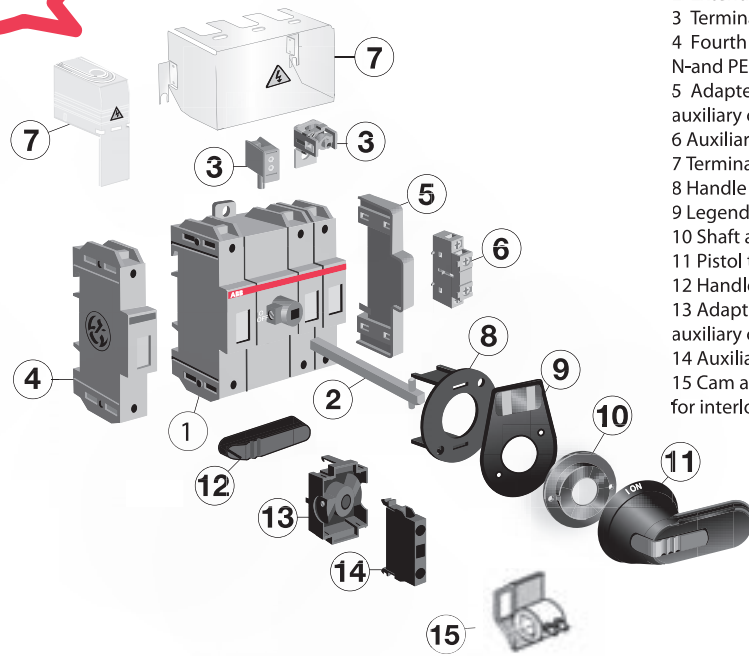

- 1 Disconnect switch
- 2 Extended shaft
- 3 Terminal clamp
- 4 Fourth pole, N-and PE-terminals
- 5 Adapter for auxiliary contact blocks
- 6 Auxiliary contact
- 7 Terminal shroud
- 8 Handle support
- 9 Legend plate
- 10 Shaft alignment ring
- 11 Pistol type handle
- 12 Handle knob
- 13 Adapter for auxiliary contact blocks
- 14 Auxiliary contact
- 15 Cam attachment for interlocking

- 1 Disconnect switch
- 2 Extended shaft
- 3 Terminal clamp
- 4 Fourth pole
- 5 Module for auxiliary contact
- 6 Auxiliary contact
- 7 Terminal shroud
- 8 Pistol type handle
- 9 Direct mounting type handle
- 10 Labelling accessories
- 11 Detachable neutral link

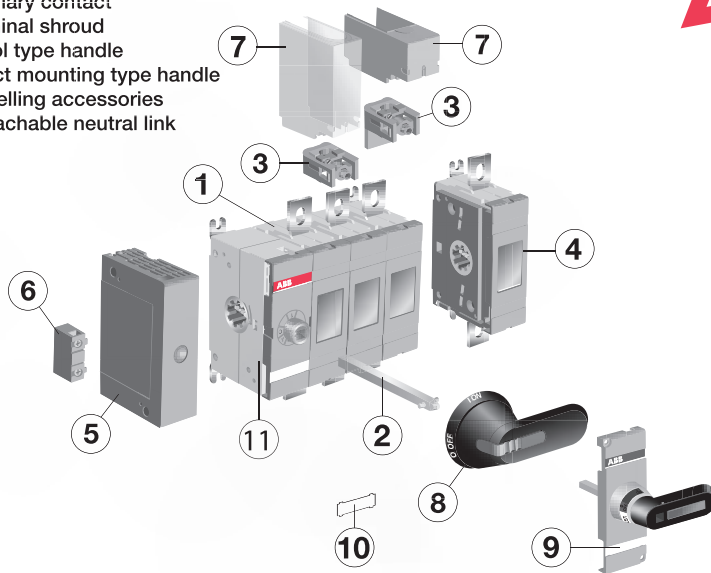

OT200... 1200

S02069A



## Complete switches

### Non-fusible disconnect switches

16A – 2000A, 600V, 3 pole<sup>①</sup>

Each kit includes:  
 1 three pole<sup>①</sup> switch  
 1 handle  
 1 shaft

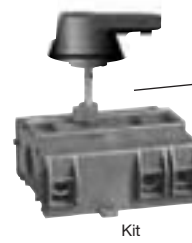

handle  
 shaft<sup>②</sup>  
 switch  
 terminal lug kit<sup>③</sup>

#### Complete switches, base & DIN rail mounted, selector handles

CSA general purpose amp rating	CSA standard C22.2 No.	Maximum horsepower rating						Complete switches catalog number	List price
		Single phase			Three phase				
		120V	240V	200V – 208V	240V	480V	600V		
16	14	1	2	3	5	10	10	OT16F3S	
25	14	1.5	3	7.5	7.5	15	20	OT25F3S	
40	14	2	5	10	10	20	25	OT40F3S	
60	14	2	7.5	15	15	30	30	OT63F3S	
80	14	2	10	20	20	40	40	OT80F3S	
30	4	2	5	10	10	20	30	OT30F3S	
60	4	3	7.5	20	20	40	40	OT60F3S	
100	4	5	15	25	30	50	50	OT100F3S	

#### Complete switches, base & DIN rail mounted, pistol handles<sup>®</sup>

CSA general purpose amp rating	CSA standard C22.2 No.	Maximum horsepower rating						Complete switches catalog number	List price
		Single phase		Three phase					
		120V	240V	200V – 208V	240V	480V	600V		
16	14	1	2	3	5	10	10	OT16F3P	
25	14	1.5	3	7.5	7.5	15	20	OT25F3P	
40	14	2	5	10	10	20	25	OT40F3P	
60	14	2	7.5	15	15	30	30	OT63F3P	
80	14	2	10	20	20	40	40	OT80F3P	
30	4	2	5	10	10	20	30	OT30F3P	
60	4	3	7.5	20	20	40	40	OT60F3P	
100	4	5	15	25	30	50	50	OT100F3P	
125	4	7.5	20	30	40	75	100	OT160E3P	
200	4	—	40	60	75	150	200	OT200U03P <sup>®</sup>	
400	4	—	—	100	125	250	350	OT400U03P <sup>®</sup>	
600	4	—	—	150	200	400	500	OT600U03P <sup>®</sup>	
800	4	—	—	200	250	500	500	OT800U03P <sup>®</sup>	
1200	4	—	—	—	—	—	—	OT1200U03P <sup>®</sup>	
1600	4	—	—	—	—	—	—	OETL-NF1600P <sup>®</sup>	
2000	4	—	—	—	—	—	—	OETL-NF2000P <sup>®</sup>	

#### Complete switches, door mounted

CSA general purpose amp rating	CSA standard C22.2 No.	Maximum horsepower rating						Complete switches catalog number	List price
		Single phase		Three phase					
		120V	240V	200V – 208V	240V	480V	600V		
16	14	1	2	3	5	10	10	OT16FT3S	
25	14	1.5	3	7.5	7.5	15	20	OT25FT3S	
40	14	2	5	10	10	20	25	OT40FT3S	
60	14	2	7.5	15	15	30	30	OT63FT3S	
80	14	2	10	20	20	40	40	OT80FT3S	
30	4	2	5	10	10	20	30	OT30FT3S	
60	4	3	7.5	20	20	40	40	OT60FT3S	
100	4	5	15	25	30	50	50	OT100FT3S	
30	4	2	5	10	10	20	30	OT30FT3P	
60	4	3	7.5	20	20	40	40	OT60FT3P	
100	4	5	15	25	30	50	50	OT100FT3P	
125	4	7.5	20	30	40	75	100	OT160ET3	

① Four poles are available — please refer to accessories page.

② Shaft is not required with door mounted switch, except OT160ET3.

③ Terminal lug kit are sold separately, see accessories page 1.21.

④ Maximum operating voltage 480V.

# Components list for non-fusible disconnect switches 16A – 2000A, 600V, 3 pole<sup>①</sup>



Each kit includes:  
1 three pole<sup>②</sup> switch  
1 handle  
1 shaft

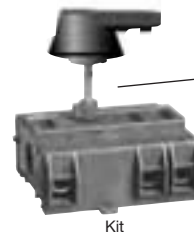

handle<sup>②</sup>  
shaft  
switch  
terminal lug kit<sup>③</sup>

## Components for base & DIN rail mounted switches with selector handles

Complete switches catalog number	Switch	Handle <sup>②</sup>				Shaft			Terminal lugs <sup>③</sup>		
	Catalog number	NEMA type	Marking	De-feat-able	Catalog number	Mounting depth <sup>④</sup> (mm)	Length (mm)	Catalog number	Wire size	Wire type	Catalog number
OT16F3S	OT16F3	1,3R,12	O/I & OFF/ON	Y	OHBS2AJ	190 – 205	180	OXS6X180	#18 – #8	Cu	Integral
OT25F3S	OT25F3	1,3R,12	O/I & OFF/ON	Y	OHBS2AJ	190 – 205	180	OXS6X180	#18 – #8	Cu	Integral
OT40F3S	OT40F3	1,3R,12	O/I & OFF/ON	Y	OHBS2AJ	190 – 205	180	OXS6X180	#18 – #8	Cu	Integral
OT63F3S	OT63F3	1,3R,12	O/I & OFF/ON	Y	OHBS2AJ	205 – 220	180	OXS6X180	#14 – #1	Cu	Integral
OT80F3S	OT80F3	1,3R,12	O/I & OFF/ON	Y	OHBS2AJ	205 – 220	180	OXS6X180	#14 – #1	Cu	Integral
OT30F3S	OT30F3	1,3R,12	O/I & OFF/ON	Y	OHBS2AJ	212.5 – 215	180	OXS6X180	#14 – #4	Cu	Integral
OT60F3S	OT60F3	1,3R,12	O/I & OFF/ON	Y	OHBS2AJ	212.5 – 215	180	OXS6X180	#14 – #4	Cu	Integral
OT100F3S	OT100F3	1,3R,12	O/I & OFF/ON	Y	OHBS2AJ	212.5 – 215	180	OXS6X180	#8 – 1/0	Cu	Integral

## Components for base & DIN rail mounted switches with pistol handles

Complete switches catalog number	Switch	Handle <sup>②</sup>				Shaft			Terminal lugs <sup>③</sup>		
	Catalog number	NEMA type	Marking	De-feat-able	Catalog number	Mounting depth <sup>④</sup> (mm)	Length (mm)	Catalog number	Wire size	Wire type	Catalog number
OT16F3P	OT16F3	1,3R,12	O/I & OFF/ON	Y	OHB65J6	175 – 190	170	OSP6X210	#18 – #8	Cu	Integral
OT25F3P	OT25F3	1,3R,12	O/I & OFF/ON	Y	OHB65J6	175 – 190	170	OSP6X210	#18 – #8	Cu	Integral
OT40F3P	OT40F3	1,3R,12	O/I & OFF/ON	Y	OHB65J6	175 – 190	170	OSP6X210	#18 – #8	Cu	Integral
OT63F3P	OT63F3	1,3R,12	O/I & OFF/ON	Y	OHB65J6	195 – 205	170	OSP6X210	#14 – #1	Cu	Integral
OT80F3P	OT80F3	1,3R,12	O/I & OFF/ON	Y	OHB65J6	195 – 205	170	OSP6X210	#14 – #1	Cu	Integral
OT30F3P	OT30F3	1,3R,12	O/I & OFF/ON	Y	OHB65J6	197.5 – 205	170	OSP6X210	#14 – #4	Cu	Integral
OT60F3P	OT60F3	1,3R,12	O/I & OFF/ON	Y	OHB65J6	197.5 – 205	170	OSP6X210	#14 – #4	Cu	Integral
OT100F3P	OT100F3	1,3R,12	O/I & OFF/ON	Y	OHB65J6	197.5 – 205	170	OSP6X210	#8 – 1/0	Cu	Integral
OT160E3P	OT160E3	1,3R,12	O/I & OFF/ON	Y	OHB65J6	185 – 215	210	OSP6X210	#8 – 1/0	Cu	Integral
OT200U03P	OT200U03	1,3R,12	O/I & OFF/ON	Y	OHB80J6	220 – 320	210	OSP6X210	#6 – 300 kcmil	Cu/Al	OZXA-200
OT400U03P	OT400U03	1,3R,12	O/I & OFF/ON	Y	OHB145J12	260 – 370	280	OSP12X280	#2 – 600 kcmil	Cu/Al	OZXA-400
OT600U03P	OT600U03	1,3R,12	O/I & OFF/ON	Y	OHB145J12	260 – 370	280	OSP12X280	(2)#2 – 600 kcmil	Cu/Al	OZXA-800
OT800U03P	OT800U03	1,3R,12	O/I & OFF/ON	Y	OHB200J12P	295 – 390	280	OSP12X280	(4)#2 – 600 kcmil	Cu/Al	OZXA-1200
OT1200U03P	OT1200U03	1,3R,12	O/I & OFF/ON	Y	OHB200J12P	295 – 390	280	OSP12X280	(4)#2 – 600 kcmil	Cu/Al	OZXA-1200
OETL-NF1600P	OETL-NF1600	1,3R,4,4X,12	OFF/ON	—	YASDA-8	340 – 585	325	OSP12X325	(4)#1/0 – 750 kcmil	Cu/Al	OZXA-28
OETL-NF2000P	OETL-NF2000	1,3R,4,4X,12	OFF/ON	—	YASDA-8	340 – 585	325	OSP12X325	(6)#1/0 – 750 kcmil	Cu/Al	OZXA-28/2

## Components for door mounted switches

Complete switches catalog number	Switch	Handle <sup>②</sup>				Shaft			Terminal lugs <sup>③</sup>		
	Catalog number	NEMA type	Marking	De-feat-able	Catalog number	Mounting depth (mm)	Length (mm)	Catalog number	Wire size	Wire type	Catalog number
OT16FT3S	OT16FT3	1,3R,12	O/I & OFF/ON	—	OHBS2PJ	No shaft required	No shaft required	No shaft required	#18 – #8	Cu	Integral
OT25FT3S	OT25FT3	1,3R,12	O/I & OFF/ON	—	OHBS2PJ				#18 – #8	Cu	Integral
OT40FT3S	OT40FT3	1,3R,12	O/I & OFF/ON	—	OHBS2PJ				#18 – #8	Cu	Integral
OT63FT3S	OT63FT3	1,3R,12	O/I & OFF/ON	—	OHBS2RJ	No shaft required	No shaft required	No shaft required	#14 – #1	Cu	Integral
OT80FT3S	OT80FT3	1,3R,12	O/I & OFF/ON	—	OHBS2RJ				#14 – #1	Cu	Integral
OT30FT3S	OT30FT3	1,3R,12	O/I & OFF/ON	—	OHBS2RJ	No shaft required	No shaft required	No shaft required	#14 – #4	Cu	Integral
OT60FT3S	OT60FT3	1,3R,12	O/I & OFF/ON	—	OHBS2RJ				#14 – #4	Cu	Integral
OT100FT3S	OT100FT3	1,3R,12	O/I & OFF/ON	—	OHBS2RJ				#8 – #1/0	Cu	Integral
OT30FT3P	OT30FT3	1,3R,12	O/I & OFF/ON	—	OHB65J6	Include OHZX6 adapter	No shaft required	No shaft required	#14 – #4	Cu	Integral
OT60FT3P	OT60FT3	1,3R,12	O/I & OFF/ON	—	OHB65J6				#14 – #4	Cu	Integral
OT100FT3P	OT100FT3	1,3R,12	O/I & OFF/ON	—	OHB65J6				#8 – 1/0	Cu	Integral
OT160ET3	OT160ET3-2	1,3R,12	O/I & OFF/ON	—	OHB65J6	—	130	OSP6X130	#8 – 1/0	Cu	Integral

① Other pole configurations available; please see individual components.

② All handles are black and accept three padlocks. For other handles please see individual components.

③ Terminal lug kit for OT/OETL switches are sold separately, see accessories page 1.21.

④ Mounting depth is the distance from the outside of door to the disconnect switch mounting plate. Shaft can be cut to desired length.



# 16A – 80A

## Manual motor controllers

### Base & DIN rail mounted, door mounted

For a complete assembly, please select one of each:

- 1 switch
- 1 handle
- 1 shaft<sup>①</sup>



OT40F3



OXPEX210



OHB65J6

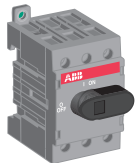

OT16-OT40F3

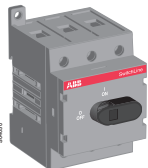

OT63-80F3



OT16F6

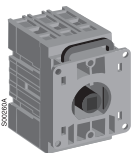

OT16-OT40FT3

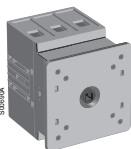

OT63-OT80FT3

### Base and DIN rail mounted, 16 – 80 Amp switches, 600V, 3 pole<sup>②</sup>

CSA general purpose amp rating	CSA standard C22.2 No.	Maximum horsepower rating						Terminal lugs		Catalog number	List price
		Single phase		Three phase				Wire size	Wire type		
		120V	240V	200V	240V	480V	600V				
16	14	1	2	3	5	10	10	#18 – #8	Cu	OT16F3 OT25F3 OT40F3	
25	14	1.5	3	7.5	7.5	15	20				
40	14	2	5	10	10	20	25				
60	14	2	7.5	15	15	30	30	#14 – #1	Cu	OT63F3 OT80F3	
80	14	2	10	20	20	40	40				

### 16 – 80 Amp switches- 600V, 6 pole

CSA general purpose amp rating	CSA standard C22.2 No.	Maximum horsepower rating						Terminal lugs		Catalog number	List price
		Single phase		Three phase				Wire size	Wire type		
		120V	240V	200V	240V	480V	600V				
16	14	1	2	3	5	10	10	#18 – #8	Cu	OT16F6 OT25F6 OT40F6	
25	14	1.5	3	7.5	7.5	15	20				
40	14	2	5	10	10	20	25				
60	14	2	7.5	15	15	30	30	#14 – #1	Cu	OT63F6 OT80F6	
80	14	2	10	20	20	40	40				

### 16 – 80 Amp switches- 600V, 3 pole change-over switches

CSA general purpose amp rating	CSA standard C22.2 No.	Maximum horsepower ratings						Terminal lugs		Catalog number	List price
		Single phase		Three phase				Wire size	Wire type		
		120V	240V	200V	240V	480V	600V				
16	14	1	2	3	5	10	10	#18 – #8	Cu	OT16F3C OT25F3C OT40F3C	
25	14	1.5	3	7.5	7.5	15	20				
40	14	2	5	10	10	20	25				
60	14	2	7.5	15	15	30	30	#14 – #1	Cu	OT63F3C OT80F3C	
80	14	2	10	20	20	40	40				

### Door mounted, 16 – 80 Amp switches, 600V, 3 pole<sup>①②</sup>

CSA general purpose amp rating	CSA standard C22.2 No.	Maximum horsepower rating						Terminal lugs		Catalog number	List price
		Single phase		Three phase				Wire size	Wire type		
		120V	240V	200V	240V	480V	600V				
16	14	1	2	3	5	10	10	#18 – #8	Cu	OT16FT3 OT25FT3 OT40FT3	
25	14	1.5	3	7.5	7.5	15	20				
40	14	2	5	10	10	20	25				
60	14	2	7.5	15	15	30	30	#14 – #1	Cu	OT63FT3 OT80FT3	
80	14	2	10	20	20	40	40				

① Door mounted switches do not require shafts  
 ② A snap on fourth pole may be added — please reference accessories pg 1.14.

# 30A – 125A

## Non-fusible disconnect switches

### Base & DIN rail mounted, door mounted



For a complete assembly,  
please select one of each:

- 1 switch
- 1 handle
- 1 shaft<sup>①</sup>

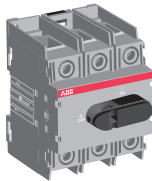
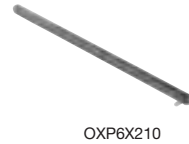

### Base and DIN rail mounted, 30 – 100 Amp switches, 600V, 3 pole<sup>②</sup>

CSA general purpose amp rating	CSA standard C22.2 No.	Maximum horsepower rating						Terminal lugs		Catalog number	List price
		Single phase		Three phase				Wire size	Wire type		
		120V	240V	200V	240V	480V	600V				
30	4	2	5	10	10	20	30	#14 – #4	Cu	OT30F3 OT60F3 OT100F3	
60	4	3	7.5	20	20	40	40	#14 – #4			
100	4	5	15	25	30	50	50	#8 – 1/0			

### 30 – 100 Amp switches- 600V, 6 pole

CSA general purpose amp rating	CSA standard C22.2 No.	Maximum horsepower rating						Terminal lugs		Catalog number	List price
		Single phase		Three phase				Wire size	Wire type		
		120V	240V	200V	240V	480V	600V				
30	4	2	5	10	10	20	30	#14 – #4	Cu	OT30F6 OT60F6 OT100F6	
60	4	3	7.5	20	20	40	40	#14 – #4			
100	4	5	15	25	30	50	50	#8 – 1/0			

### 30 – 100 Amp switches- 600V, 3 pole change-over switches

CSA general purpose amp rating	CSA standard C22.2 No.	Maximum horsepower ratings						Terminal lugs		Catalog number	List price
		Single phase		Three phase				Wire size	Wire type		
		120V	240V	200V	240V	480V	600V				
30	4	2	5	10	10	20	30	#14 – #4	Cu	OT30F3C OT60F3C OT100F3C	
60	4	3	7.5	20	20	40	40	#14 – #4			
100	4	5	15	25	30	50	50	#8 – 1/0			

### Door mounted, 30 – 100 Amp switches, 600V, 3 pole<sup>①②</sup>

CSA general purpose amp rating	CSA standard C22.2 No.	Maximum horsepower rating						Terminal lugs		Catalog number	List price
		Single phase		Three phase				Wire size	Wire type		
		120V	240V	200V	240V	480V	600V				
30	4	2	5	10	10	20	30	#14 – #4	Cu	OT30FT3 OT60FT3 OT100FT3	
60	4	3	7.5	20	20	40	40	#14 – #4			
100	4	5	15	25	30	50	50	#8 – 1/0			

### Base & DIN rail mounted, 125 Amp switches, 600V

CSA general purpose amp rating	CSA standard C22.2 No.	Maximum horsepower rating						Terminal lugs		Catalog number	List price
		Single phase		Three phase				Wire size	Wire type		
		120V	240V	200V	240V	480V	600V				
<b>2 pole</b> 125	—	—	—	—	—	—	—	#8 – 1/0	Cu	OT160E2	
<b>3 pole</b> 125	4	7.5	20	30	40	75	100	#8 – 1/0	Cu	OT160E3	

### 125 Amp Door mounted switch, 600V, 3 pole

CSA general purpose amp rating	CSA standard C22.2 No.	Maximum horsepower rating						Terminal lugs		Catalog number	List price
		Single phase		Three phase				Wire size	Wire type		
		120V	240V	200V	240V	480V	600V				
125	4	7.5	20	30	40	75	100	#8 – 1/0	Cu	OT160ET3-2	

① Door mounted switches do not require shafts, except OT160ET3-2  
 ② A snap on fourth pole may be added — please reference accessories pg 1.14.

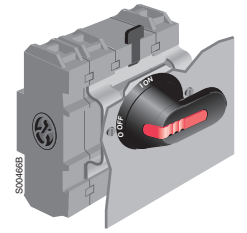
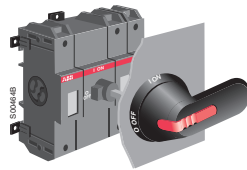



# Handles

for 16A – 125A non-fusible disconnect switches  
Base & DIN rail mounted

## Selector handles — for use with shafts (□ 6 x 6 mm)

NEMA type	IEC type	Color	Marking	Defeatable	Padlockable	Dim. (mm <sup>2</sup> )	Catalog number	List price
<b>All marked both O/I &amp; Off/On</b>								
1	IP54	Blk	O/I & OFF/ON	—	Yes	48	OHBS3AH1 <sup>①</sup>	
1	IP54	Red/Yel	O/I & OFF/ON	—	Yes	48	OHYS3AH1 <sup>①</sup>	
1, 3R,12	IP65	Blk	O/I & OFF/ON	Yes	Yes	65	OHBS2AJ	
1, 3R,12	IP65	Grey	O/I & OFF/ON	Yes	Yes	65	OHGS2AJ	
1, 3R,12	IP65	Red/Yel	O/I & OFF/ON	Yes	Yes	65	OHYS2AJ	
1, 3R,12	IP65	Blk	I / O / II	Yes	Yes	65	OHBS2AJE011	
1, 3R,12	IP65	Red/Yel	I / O / II	Yes	Yes	65	OHYS2AJE011	
1, 3R,12	IP65	SS HASP	O/I & OFF/ON	Yes	Yes	65	OHBS2AJEH	

## Round Padlockable handles

Padlockable in 0-position, max 3 padlocks with max 8 mm hasp diameter.

NEMA type	IEC type	Color	Marking	Defeatable	Padlockable	Dim. (mm <sup>2</sup> )	Catalog number	List price
NEMA 4X	IP65	Black	OFF/ON	Yes	Yes	66x66	OZ331PB	
NEMA 4X	IP65	Red/Yel	OFF/ON	Yes	Yes	66x66	OZ331PRY	
<b>Handles with door coupling in ON-position, Shaftalignment ring for OZ371P handle</b>								
NEMA 4X	IP65	Black	OFF/ON	No	Yes	66x66	OZ371PB	
NEMA 4X	IP65	Red/Yel	OFF/ON	No	Yes	66x66	OZ371PRY	

## Selector handles, Door mounted switches

NEMA type	IEC type	Color	Marking	Defeatable	Padlockable	Dim. (mm <sup>2</sup> )	Catalog number	List price
<b>All marked both O/I &amp; Off/On</b>								
<b>Snap-on mounting — for use on OT16FT3 – OT40FT3</b>								
1	IP54	Blk	O/I & OFF/ON	—	Yes	48	OHBS3PH	
1	IP54	Red/Yel	O/I & OFF/ON	—	Yes	48	OHYS3PH	
1,3R,12	IP65	Blk	O/I & OFF/ON	—	Yes	65	OHBS2PJ	
1,3R,12	IP65	Red/Yel	O/I & OFF/ON	—	Yes	65	OHYS2PJ	
1, 3R,12	IP65	SS HASP	O/I & OFF/ON	—	Yes	65	OHBS2PJEH	

## Screw mounting — for use on OT16FT3 – OT80FT3

NEMA type	IEC type	Color	Marking	Defeatable	Padlockable	Dim. (mm <sup>2</sup> )	Catalog number	List price
1	IP54	Blk	O/I & OFF/ON	—	Yes	48	OHBS3RH	
1	IP54	Red/Yel	O/I & OFF/ON	—	Yes	48	OHYS3RH	
1,3R,12	IP65	Blk	O/I & OFF/ON	—	Yes	65	OHBS2RJ	
1,3R,12	IP65	Red/Yel	O/I & OFF/ON	—	Yes	65	OHYS2RJ	

## Pistol handles — for use with shafts (□ 6 x 6 mm) <sup>②</sup> padlockable with three padlocks in OFF-position, door interlock in ON-position.

NEMA type	IEC type	Color	Marking	Defeatable	Padlockable	Shaft size (mm <sup>2</sup> )	Catalog number	List price
1, 3R, 12	IP65	Black	O/I & Off/On	Yes	Yes	6	OHB45J6	
		Red/Yel	O/I & Off/On	Yes	Yes	6	OHY45J6	
		Black	O/I & Off/On	Yes	Yes	6	OHB65J6	
		Grey	O/I & Off/On	Yes	Yes	6	OHG65J6	
		Red/Yel	O/I & Off/On	Yes	Yes	6	OHY65J6	
		Black	O/I & Off/On	Yes	Yes	6	OHB80J6	
		Grey	O/I & Off/On	Yes	Yes	6	OHG80J6	
		Red/Yel	O/I & Off/On	Yes	Yes	6	OHY80J6	
1, 3R, 4, 4X,12	IP66	Black	O/I & Off/On	Yes	Yes	6	OHB65L6	
		Red/Yel	O/I & Off/On	Yes	Yes	6	OHY65L6	
		Black	O/I & Off/On	Yes	Yes	6	OHB80L6	
		Red/Yel	O/I & Off/On	Yes	Yes	6	OHY80L6	
1, 3R, 4, 4X,12	IP65	SS	O/I & Off/On	Yes	Yes	6	OHB65L6	
1, 3R, 12	IP65	Black	I / O / II	Yes	Yes	6	OHB65J6E011	
		Red/Yel	I / O / II	Yes	Yes	6	OHY65J6E011	
1, 3R, 4, 4x, 12	IP66	Black	I / O / II	Yes	Yes	6	OHB65L6E011	
		Red/Yel	I / O / II	Yes	Yes	6	OHY65L6E011	

<sup>①</sup> Not suitable for use with OT30F3, OT60F3, OT100F3

<sup>②</sup> Plastic pistol grip handle with stainless steel hasp, add suffix EH. ex.: OHB65SJ6EH

# Shafts

for 16A – 125A non-fusible disconnect switches  
Base & DIN rail mounted



### Shafts — for use with OH selector handles (□ 6 x 6 mm)



Mounting depth<sup>Ⓢ</sup> in mm

Shaft length (mm)	OT16F3 OT25F3 OT40F3		OT63F3 OT80F3		OT30F3 OT60F3 OT100F3	Catalog number	List price
	OH_3_	OH_2_	OH_3	OH_2_	OH_2_		
85	105 – 125	90 – 110	125 – 140	110 – 125	100 – 125	OXS6X85 OXS6X130 OXS6X180 OXS6X250 OXS6X330 OXS6X455	
130	150 – 170	135 – 155	170 – 185	155 – 170	145 – 170		
180	200 – 220	185 – 205	220 – 235	205 – 220	195 – 220		
250	270 – 290	255 – 275	290 – 305	275 – 290	265 – 290		
330	350 – 370	335 – 355	370 – 385	355 – 370	345 – 370		
455	475 – 495	460 – 480	495 – 510	480 – 495	470 – 495		

### Shafts — for use with pistol handles (□ 6 x 6 mm)



Mounting depth<sup>Ⓢ</sup> in mm

Shaft length (mm)	OT16F3 OT25F3 OT40F3		OT63F3 OT80F3		OT30F3 OT60F3 OT100F3	Catalog number	List price
150	155 – 170		175 – 185		160 – 185	OXP6X150 OXP6X170 OXP6X265 OXP6X400 OXP6X500 OXP6X700	
170	175 – 190		195 – 205		180 – 205		
265	270 – 285		290 – 300		275 – 300		
400	405 – 420		425 – 435		410 – 435		
500	505 – 520		525 – 535		510 – 535		
700	705 – 720		725 – 735		710 – 735		

<sup>Ⓢ</sup> Mounting depth is the distance from the outside of door to the disconnect switch mounting plate. Shaft can be cut to desired length.



# Accessories

for 16A – 125A non-fusible disconnect switches  
Base & DIN rail mounted, door mounted

## Base and DIN rail mounted switches

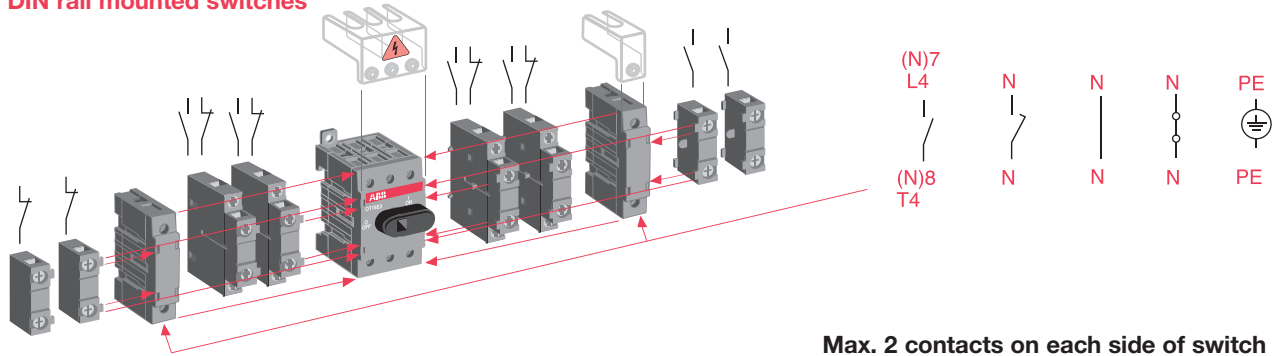

## Auxiliary contacts — snap-on mounting

Description	For use on:	AC thermal amp rating	AC rated voltage	Catalog number	List price
1 N.O. mounts on right side (2 max)	OT16F(T)3 - OT100F(T)3 OT16F3C - OT100F3C	10	600	OA1G10	
1 N.O. Gold plated	OT16F(T)3 - OT100F(T)3	10	600	OA1G10AU	
1 N.O. mounts on left side (2 max)	OT16F3C - OT100F3C	10	600	OA7G10	
1 N.C. mounts on left side (2 max)	OT16F(T)3 - OT100F(T)3 OT16F3C - OT100F3C	10	600	OA1G01	
1 N.C. Gold plated	OT16F(T)3 - OT100F(T)3	10	600	OA1G01AU	
1 N.C. mounts on right side (2 max)	OT16F3C - OT100F3C	10	600	OA8G01	
1 N.O. + 1 N.C. mounts on left or right hand side of switch	OT16F3 - OT100F3	10	600	OA2G11 <sup>①</sup>	

① OT16\_40: max. 2NO+2NC, OT63...100: max 4NO+4NC

## Auxiliary contacts top mounted<sup>②</sup>

- OEZNP1 mounting base required to mount auxiliary contacts (order separately) max 6 aux. blocks. Early break type

Description	For use on:	AC thermal amp rating	AC rated voltage	Catalog number	List price
1 N.O.	OT160E3	10	600	OBEA10	
1 N.C.		10	600	OBEA01	
1 N.O. gold plated		10	600	OBEA-10AU	
1 N.C. gold plated		10	600	OBEA-01AU	
Mounting base on top	OBEA_			OEZNP1	

## Auxiliary contacts side mounted<sup>②</sup>

- Accepts four contacts maximum (2 blocks/side)

Description	For use on:	AC thermal amp rating	AC rated voltage	Catalog number	List price
1 N.O. + 1 N.C.	OT160E3	10	600	OA2G11	
	Mounting base required for OA2G11			OAZX1	

② When using OBEA\_ auxiliary contacts, mounting base OEZNP1 is required, and when using OA2G11, mounting base OAZX1 is required.



# Accessories

for 16A – 125A non-fusible disconnect switches  
Base & DIN rail mounted, door mounted



OTP\_40\_



OTP\_80\_



OTP\_125\_

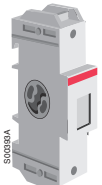

OTP\_160EP

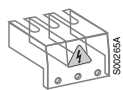

OTS\_T3



OTS\_T1

### Power poles — Only one power pole per switch, mounts on left or right side of switch

Description	For use on:	AC thermal amp rating	AC rated voltage	Catalog number	List price
 Fourth pole	OT16F3 – OT40F3	40	600	OTPS40FPN1*	
	OT16F3 – OT40F3	40	600	OTPS40FPN2*	
	OT63F3 – OT80F3	80	600	OTPS80FP	
	OT30F3 – OT60F3	60	600	OTPS60FP	
	OT100F3 OT160E3, ET3	100 125	600 600	OTPS125FP OTPS160EP	
 Late-break/early-make	OT16F3 – OT40F3	40	600	OTPL40FP	
	OT63F3 – OT80F3	80	600	OTPL80FP	
	OT30F3, OT60F3	60	600	OTPL60FP	
	OT100F3	100	600	OTPL125FP	
 Fourth pole	OT16FT3 – OT40FT3	40	600	OTPS40FDN1	
	OT16FT3 – OT40FT3	40	600	OTPS40FDN2	
	OT63FT3 – OT80FT3	80	600	OTPS80FD	
	OT30FT3, OT60FT3	60	600	OTPS60FD	
	OT100FT3	100	600	OTPS125FD	
 Late-break/early-make	OT16FT3 – OT40FT3	40	600	OTPL40FD	
	OT63FT3 – OT80FT3	80	600	OTPL80FD	
	OT30FT3, OT60FT3, OT100FT3	60 100	600 600	OTPL60FD OTPL125FD	

\* N1 = On the left side of the switch N2 = On the right side of the switch

### Terminal poles — Switch accepts one terminal pole per side, mounts on left or right side of switch

Description	For use on:	AC thermal amp rating	AC rated voltage	Catalog number	List price
 Solid neutral Base & DIN rail mounted	OT16F3 – OT40F3	40	600	OTPN40FP	
	OT63F3 – OT80F3	80	600	OTPN80FP	
	OT30F3, OT60F3, OT100F3	60 100	600 600	OTPN125FP OTPN160EP	
	OT160E3, ET3	125	600		
 Detachable neutral Base & DIN rail mounted	OT16F3 – OT40F3	40	600	OTPD40FP	
	OT63F3 – OT80F3	80	600	OTPD80FP	
	OT30F3, OT60F3	60	600	OTPD60FP	
	OT100F3	100	600	OTPD125FP	
 Ground terminal Base & DIN rail mounted	OT16F3 – OT40F3	40	600	OTPE40FP	
	OT63F3 – OT80F3	80	600	OTPE80FP	
	OT30F3, OT60F3	60	600	OTPE60FP	
	OT100F3 OT160E3, ET3	100 125	600 600	OTPE125FP OTPE160EP	
 Solid neutral Door mounted	OT16FT3 – OT40FT3	40	600	OTPN40FD	
	OT63FT3 – OT80FT3	80	600	OTPN80FD	
	OT30FT3, OT60FT3, OT100FT3	60 100	600 600	OTPN125FD	
 Detachable neutral Door mounted	OT63FT3 – OT80FT3	80	600	OTPD80FD	
 Ground terminal Door mounted	OT16FT3 – OT40FT3	40	600	OTPE40FD	
	OT63FT3 – OT80FT3	80	600	OTPE80FD	
	OT30FT3, OT60FT3	60	600	OTPE60FD	
	OT100FT3	100	600	OTPE125FD	

### Terminal shrouds — snap on mounting for line or load side

Description	For use on:	Catalog number	List price
3 pole includes one shroud for line or load side	OT16F3 – OT40F3, -FT3 OT63F3 – OT80F3, -FT3 OT30F3, OT60F3, OT100F3, -FT3 OT160E3	OTS40T3 OTS63T3 OTS125T3 OTS160T3	
For 1 to 4-pole switches, shroud for single pole and for fourth	OTP_40F- OTP_80F- OTP_60F, OTP_125F OT160E	OTS40T1 OTS63T1 OTS125T1 OTS160T1	

\*\* All disconnects are IP20 touch safe as standard. Terminal shrouds provide an additional level of protection.



## Accessories

for 16A – 125A non-fusible disconnect switches  
Base & DIN rail mounted

### Replacement Knob – mounts directly to switch; no shaft necessary.

UL/NEMA type	Color	For use on :	Length (MM)	Padlockable	Catalog number	List price
1	Black	OT16...40	25	–	CXBY68989	
1	Black	OT63... 80,OT30,60,100	35	–	CXBY68998	
1	Black	OT63-80, OT30-100	40	Yes	OHBS2	
1	Black	OT16 - OT40	–	Yes	OHBS12	
1	Black	OT160	72	–	OHB13	
1	Black	OT80 - OT100	–	Yes	OHB2/1	
Metal collar		OT16 - OT100	–	–	OTZS1	
Metal collar		OT160	–	–	OTZS2	
Red knob for locking shaft in place **re-use original set screw **		OT160	–	–	CXBY68100	
Set screw ①		OT16- OT100	–	–	FLSWM5X8AY	

(1) Set screw for use with knob or collar, to be ordered separately.  
Red/Yellow handles are available by substituting the OHB prefix with OHY.

### Modular adapter cover – for OT16, OT25, OT40

Item	For use on :	Length (inches)	Padlockable	Catalog number	List price
Adapter cover grey	OT16, OT25, OT40	–	Yes	OHBS7	
Adapter cover yellow	OT16, OT25, OT40	–	Yes	OHYS7	

A padlock can be used with the adapter cover.

### Locking clip – (replacement part)

Description	For use on :	Catalog number	List price
Door mounted switch handle locking clip	OT16, OT25, OT40	CXBY68140	

### Handle support – (for direct mounting on the switch mechanism for OH\_65, 80 handles)

Description	For use on:	Catalog number	List Price
Handle Support	OT160E3	OHZX5	



OHRS2



OHBS11



OHBS12



OTZS1



OHY7



CXBY68140



OHZX5

# Accessories for 16A - 100A Non-fusible disconnect switches

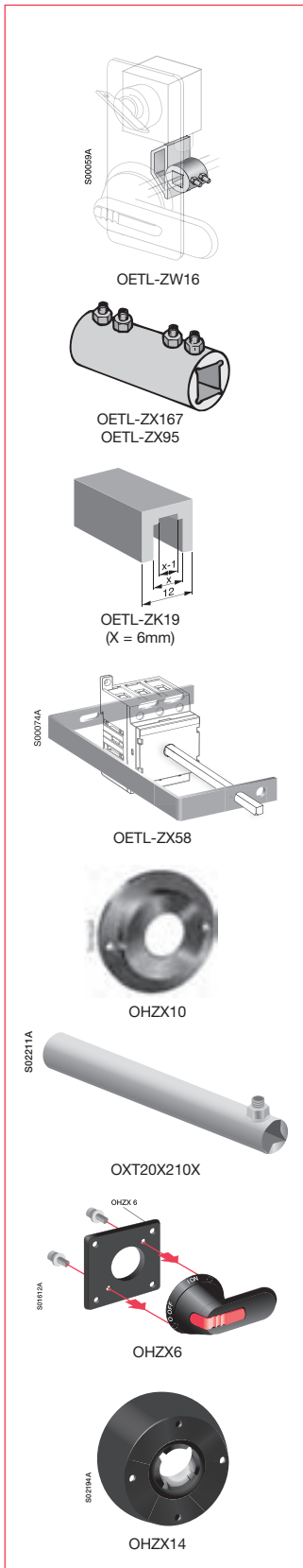

## Locking accessories

Description	For use on:	Catalog number	List price
<b>Cam attachment</b> for Kirk Key interlock. The interlock is not included.	6 & 8mm shafts	OETL-ZW16	

## Shaft extension couplers

Description	For use on:	Catalog number	List price
Joins two shafts together for applications where extended length is required	for 6mm shafts for 12mm shafts	OESA-ZX167 OETL-ZX95	

## Shaft adapter

Description	For use on:	Catalog number	List price
Adapts one end of a 6mm shaft to 12mm. The adapter can be placed inside the extension coupler OETLZX95	6mm shafts	OETL-ZK19	

## Stainless steel hasp

Description	For use on:	Catalog number	List price
Replacement stainless steel hasp	Selector handle Pistol handle	OHZX12 OHZX13	

## Shaft support

Description	For use on:	Catalog number	List price
Shaft support	OT16F3 – OT100F3	OETL-ZX58	

## Pistol handle adapter, door mounted switches

Description	For use on:	Catalog number	List price
Adapter piece for pistol handle	OT30FT3, OT60FT3, OT100FT3	OHZX6	

## Shafts alignment ring, improves the handle operation if a handle and a shaft have been poorly aligned

Description	For use on:	Catalog number	List price
Pistol Handles	OH_45, 65, 80, 125, 145, 175J, L	OHZX10	
Selector Handles	OH_2, 3, AH, AJ	OHZX11	

(1) fits all pistol grip handles, mounts on the inside of the enclosure door with provided hardware.

## Shaft tube

Description	For use on:	Catalog number	List price
Supporting 12mm shafts longer than 280mm	12mm shafts	OXT20X210X	

## Extension ring for pistol type handles

Description	For use on:	Catalog number	List price
Black	OHB_	OHZX14	



# Accessories for 16A - 200A Non-fusible disconnect switches



OTZW8



OESA-ZW2

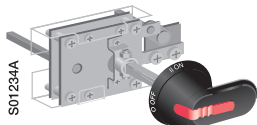

OESA-ZW1

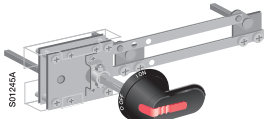

OTZW17

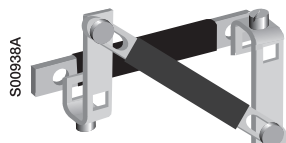

OTZW24

### Conversion mechanisms

- For use with Base and DIN rail mounted switches only
- Switches are not included

Description	For use on:	Catalog number	List price
6 or 8 pole	OT16F3 - OT100F3	OTZW8	
Transfer		OESA-ZW1	
Bypass		OTZW17	
Mechanical Interlock		OTZW24	
6 or 8 pole	OT160E3 - OT200U3	OESA-ZW2	
Transfer		OTZW25	
By pass		OTZW26	
Mechanical Interlock		OTZW10	

Conversion kit type	To be ordered separately		Included in conversion kit delivery		The standard handle or shaft of one of the combined switches can be used	
	Shaft	Handle	Shaft	Handle	Shaft	Handle
<b>6 and 8-pole switches</b>						
OESA-ZW2	-	-	x (2 pcs)	OHB145J12	-	-
<b>Change-over switches</b>						
OESAZW1	-	-	x (2 pcs)	OHB80J6E011	-	-
OTZW25	-	-	x (2 pcs)	OHB95J12E011	-	-
<b>By-pass switches</b>						
OETLZW17	-	-	x (3 pcs)	OHB80J6E011	-	-
OETLZW26	-	-	x (3 pcs)	OHB95J12E011	-	-
<b>Mechanical interlock</b>						
OTZW24	-	-	-	-	x	x
OTZW10	-	-	-	-	x	x

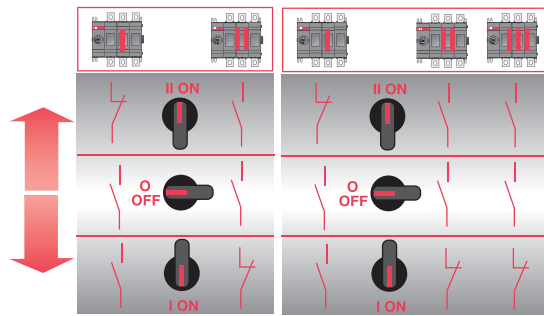

Change-over switches      By-pass switches

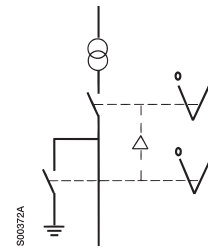

Mechanical interlock

S01233A

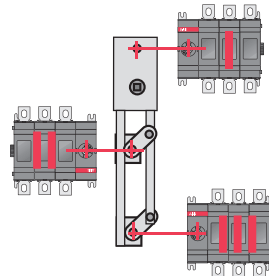

Change-over switches

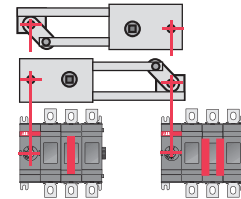

Change-over switches

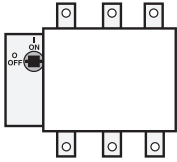

## 200A – 2000A Non-fusible disconnect switches



For a complete assembly,  
please select one of each:

- 1 switch
- 1 handle
- 1 shaft
- 1 terminal lug kit



OT200U03



OXP6X210



OHB80J6



OZXA-200

### 200 Amp switches, 600V

CSA general purpose amp rating	CSA standard C22.2 No.	Maximum horsepower rating					Catalog number	List price	
		Three phase							
		200V	208V	240V	480V	600V			
<b>2 pole</b>	200	4	30/1Ph	40/1Ph	40/1Ph	—	—	OT200U02	
<b>3 pole</b>	200	4	60	60	75	150	200	OT200U03	
	200	4	60	60	75	150	200	OT200U12	
	200	4	60	60	75	150	200	OT200U30	
<b>4 pole</b>	200	4	60	60	75	150	200	OT200U04	

### 400 – 800 Amp switches, 600V

CSA general purpose amp rating	CSA standard C22.2 No.	Maximum horsepower rating					Catalog number	List price	
		Three phase							
		200V	208V	240V	480V	600V			
<b>2 pole</b>	400	4	—	—	—	—	—	OT400U02	
	600	4	—	—	—	—	—	OT600U02	
	800	4	—	—	—	—	—	OT800U02	
<b>3 pole</b>	400	4	100	100	125	250	350	OT400U03	
	400	4	100	100	125	250	350	OT400U12	
	400	4	100	100	125	250	350	OT400U30	
	600	4	150	150	200	400	500	OT600U03	
	600	4	150	150	200	400	500	OT600U12	
	600	4	150	150	200	400	500	OT600U30	
	800	4	200	200	250	500	500	OT800U03	
	800	4	200	200	250	500	500	OT800U12	
	800	4	200	200	250	500	500	OT800U30	
<b>4 pole</b>	400	4	100	100	125	250	350	OT400U04	
	600	4	150	150	200	400	500	OT600U04	
	800	4	200	200	250	500	500	OT800U04	

### 1200 – 2000 Amp switches, 600V <sup>Ⓢ</sup> Maximum operating voltage: 480V

CSA general purpose amp rating	CSA standard C22.2 No.	Maximum horsepower rating					Catalog number	List price	
		Three phase							
		200V	208V	240V	480V	600V			
<b>2 pole</b>	1200	4	The Canadian Electric Code does not specify HP ratings for switches this large. Please select a switch based on 115% of application FLA. For example: a motor with an FLA of 800A would require a 1200A switch: 800A x 115% = 920A, the closest higher rated switch is 1200A.					OT1200U02	
	1600	4						OETL-NF1600-2	
	2000	4						OETL-NF2000-2 <sup>Ⓢ</sup>	
<b>3 pole</b>	1200	4	The Canadian Electric Code does not specify HP ratings for switches this large. Please select a switch based on 115% of application FLA. For example: a motor with an FLA of 800A would require a 1200A switch: 800A x 115% = 920A, the closest higher rated switch is 1200A.					OT1200U03	
	1200	4						OT1200U12	
	1600	4						OETL-NF1600	
<b>4 pole</b>	—	—	The Canadian Electric Code does not specify HP ratings for switches this large. Please select a switch based on 115% of application FLA. For example: a motor with an FLA of 800A would require a 1200A switch: 800A x 115% = 920A, the closest higher rated switch is 1200A.					OT1200U04	
	—	—						OETL-NF1600-4	
	—	—						OETL-NF2000-4 <sup>Ⓢ</sup>	

### 200 – 1200 Amp change-over switches – bridging bars on page 1.14 to be ordered separately

CSA general purpose amp rating	CSA standard C22.2 No.	Maximum horsepower rating					Catalog number	List price	
		Three phase							
		200V	208V	240V	480V	600V			
<b>3 pole</b>	200	4	60	60	75	150	200	OT200U03C	
	400	4	100	100	125	250	350	OT400U03C	
	600	4	150	150	200	400	500	OT600U03C	
	800	—	200	200	250	500	500	OT800U03C	
	1200	—	—	—	—	—	—	OT1200U03C	
<b>4 pole</b>	200	4	60	60	75	150	200	OT200U04C	
	400	4	100	100	125	250	360	OT400U04C	
	600	4	150	150	200	400	500	OT600U04C	
	800	—	200	200	250	500	500	OT800U04C	
	1200	—	—	—	—	—	—	OT1200U04C	

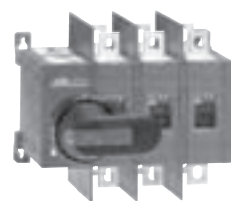

OT200U03CP



## 200A – 2000A Non-fusible disconnect switches

### Pistol handles — for use with (□ 6 x 6 mm) OT200 ②

NEMA type	IEC type	Color	Length mm	Marking	Defeatable	Padlockable	Catalog number	List price
1, 3R, 12	IP65	Blk	80	O/I & Off/On	Yes	Yes	OHB80J6	
1, 3R, 12	IP65	Grey	80	O/I & Off/On	Yes	Yes	OHG80J6	
1, 3R, 12	IP65	R/Y	80	O/I & Off/On	Yes	Yes	OHY80J6	
1, 3R, 4, 4X, 12	IP66	Blk	80	O/I & Off/On	Yes	Yes	OHB80L6	
1, 3R, 4, 4X, 12	IP66	R/Y	80	O/I & Off/On	Yes	Yes	OHY80L6	
1, 3R, 4, 4X, 12	IP66	SS	65	O/I & Off/On	Yes	Yes	OHM65L6	

### Shafts — for use with pistol handles (□ 6 x 6 mm)

Shaft length mm	Mounting depth <sup>①</sup> in mm	Catalog number	List price
150	129 – 194	EXP6X150	
210	189 – 254	EXP6X210	
290	269 – 334	EXP6X290	
360	339 – 404	EXP6X360	
430	409 – 474	EXP6X430	
700	675 – 705	EXP6X700	

### Pistol handles — for use with shafts (□ 12 x 12 mm) OT400...OETL-NF2000 ②

NEMA type	IEC type	Color	Length in mm	Marking	Defeatable	Padlockable	Catalog number	List price
1,3R,12	IP65	Blk	145	O/I & Off/On	Yes	Yes	OHB145J12	
1,3R,12	IP65	Grey	145	O/I & Off/On	Yes	Yes	OHG145J12	
1,3R,12	IP65	R/Y	145	O/I & Off/On	Yes	Yes	OHY145J12	
1,3R,12	IP65	Blk	175	O/I & Off/On	Yes	Yes	OHB175J12	
1,3R,12	IP65	R/Y	175	O/I & Off/On	Yes	Yes	OHY175J12	
1,3R,12	IP65	Blk	2 x 200	O/I & Off/On	Yes	Yes	OHB200J12P	
1,3R,4,4X	IP65	Blk	2 x 200	O/I & Off/On	Yes	Yes	OHB200L12P	
1,3R,4,4X	IP65	SS	2 x 200	O/I & Off/On	Yes	Yes	OHM200L12P	
1,3R,4,4X,12	IP66	Blk	145	O/I & Off/On	Yes	Yes	OHB145L12	
1,3R,4,4X,12	IP66	R/Y	145	O/I & Off/On	Yes	Yes	OHY145L12	
1,3R,4,4X,12	IP66	Blk	175	O/I & Off/On	Yes	Yes	OHB175L12	
1,3R,4,4X,12	IP66	R/Y	175	O/I & Off/On	Yes	Yes	OHY175L12	
1,3R,4,4X,12	IP65	Metal	220	Off/On	—	Yes	YASDA-8	
1,3R,4,4X,12	IP66	SS	125	O/I & Off/On	Yes	Yes	OHM125L12	
1,3R,4,4X,12	IP66	SS	175	O/I & Off/On	Yes	Yes	OHM175L12	
1,3R,4,4X,12	IP66	SS	275	O/I & Off/On	Yes	Yes	OHM275L12	

### Shafts — for use with pistol handles (□ 12 x 12 mm)

Shaft length mm	Mounting depth <sup>①</sup> in mm	Catalog number	List price
For use on:	OT400, 600	OT800U03 - OT1200U03	OETL-NF1600,2000
280	260-340	295-390	—
325	305-385	350-435	350-435
395	375-455	410-505	410-505
465	445-525	480-575	480-575
535	515-595	550-645	550-645
625	605-685	640-735	640-735
			EXP12X280
			EXP12X325
			EXP12X395
			EXP12X465
			EXP12X535
			EXP12X625

### Shafts alignment ring — for use on :

Description	For use on:	Catalog number	List price
Pistol Handles	OH_45...275J5...12	OHZX10	

### Direct Mounted Handle

Description	For use on:	Catalog number	List price
Padlockable with 3 padlocks in O-position	OT200	OTV250EK	
Includes shaft and mechanism	OT400	OTV400EK	
	OT600	OTV800EK	
	OT800-OT1200	OTV1000EK	
Mounts on shaft	OETL-NF1600, 2000	YASDA-34	

### Replacement Parts

Accessory Type	Description	For use on:	Catalog number	List price
Metal Collar	for locking shaft in place	OT200	OTZS2	
Set Screw	Set screw for use with knob or collar	OT200	FLSWM5X6X	

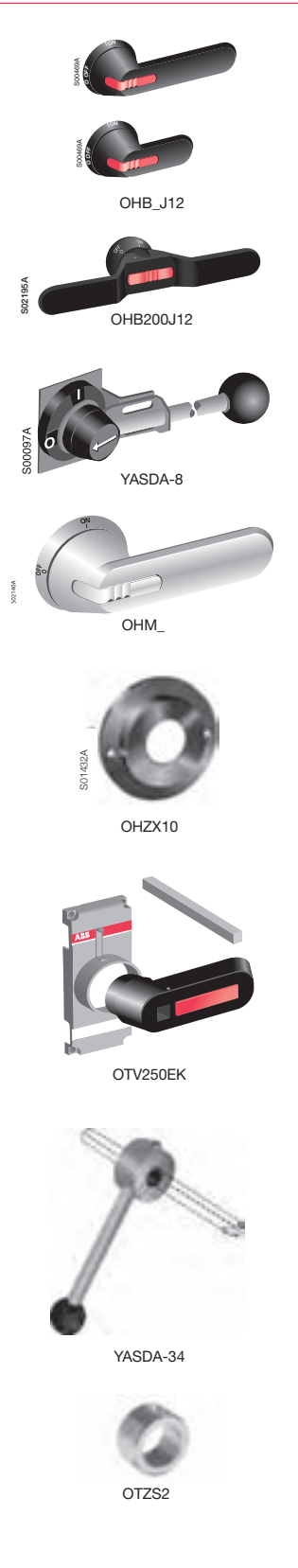

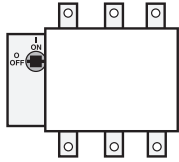

## Accessories for 200- 1200A Non-fusible disconnect switches



OHB\_

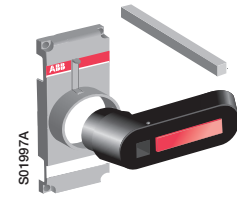

OTV\_

### Handles, door mounting

Plastic I - 0 - II handle, NEMA 1, 12, 3R and IP65, padlockable with three padlocks in 0-position, door interlock in I- and II-position and when padlocked.

Suitable for switches	Colour	Shaft diam. [mm]	Catalog number	List Price
OT200U_C	black	6	OHB80J6E011	
OT400U_C	black	12	OHB145J12E011	
OT600U_C	black	12	OHB145J12E011	

Plastic I - 0 - II handle, IP65, padlockable with three padlocks in I- , 0- and II-position, door interlock in I- and II-position and when padlocked.

Suitable for switches	Colour	Shaft diam. [mm]	Catalog number	List Price
OT200U_C	black	6	OHB80J6E311	
OT400U_C	black	12	OHB145J12E311	
OT600U_C	black	12	OHB145J12E311	

★ – Coil voltage

Pistol type handle, plastic, IP65, Nema type 1, 3R, 12. Indication I-O-II. Door interlock in I- and II-position and when padlocked. Padlocking possibility with three padlocks, bail dia ? 5...10 mm. Padlockable in the 0-position

Suitable for switches	Colour	Shaft diam. [mm]	Catalog price	List
OT400U_C	black	12	OHB200J12PE011	
OT600U_C	black	12	OHB200J12PE011	

### Handles, direct mounting

Plastic I - 0 - II handle, padlockable with three padlocks in 0-position. Includes a shaft and a mechanism cover. Types -ECMK include also microswitches.

Suitable for switches	Colour	Shaft diam. [mm]	Catalog price	List
OT200U_C	black	shaft included	OTV250ECK	
OT400U_C	black	shaft included	OTV400ECK	
OT600U_C	black	shaft included	OTV800ECK	

Metallic handles, IP65, Nema types 1, 3R, 4, 4X, 12. Indication I - 0 - II. Padlockable with 3 padlocks in OFF- position, door interlock in I- and II- position.

Handle length [mm]	Colour	Shaft diam. [mm]	Catalog price	List
220	Metal	12	YASDA21	
320	Metal	12	YASDA6	

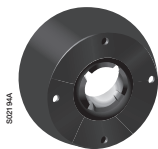

OHZX14

### Extension ring for pistol type handles

Description	For use on:	Catalog number	List price
Black	OHB_	OHZX14	



## Accessories for 200 – 2000A Non-fusible disconnect switches



OZXA-200

OZXA-400

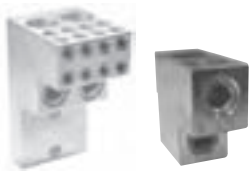

OZXA-32

OZXA-800

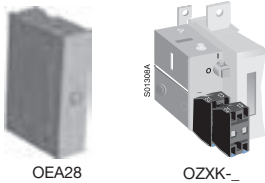

OEA28

OZXK-  
S01308A



OTS-L

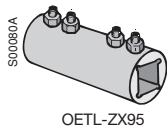

OETL-ZX95

### Terminal lug kits

For use on:	Wire size	Wire type	Terminal lugs per kit	Kit catalog number	List price
OT200	#4 – 300 kcmil	Cu/Al	6	OZXA-200	
	(6)#14 – #6 AWG	Cu/Al	3	OZXA-206T	
OT400	#2 – 600 kcmil	Cu/Al	6	OZXA-400	
	(2) #2 – 300 kcmil	Cu/Al	6	OZXA-402	
	(6) #14 – #6 AWG	Cu/Al	3	OZXA-406	
	(2) #4 – 500 kcmil	Cu/Al	6	OZXA-33	
OT600	(2) #2 – 600 kcmil	Cu/Al	6	OZXA-800	
OT800, OT1200	(4) #2 – 600 kcmil	Cu/Al	6	OZXA-1200	
OETL-NF1600	(4) #1/0 – 750 kcmil	Cu/Al	6	DSK8TL	
OETL-NF2000	(6) #1/0 – 750 kcmil	Cu/Al	6	DSK8TM	
OETL-NF800,NF1200,NF1600	(8) 2/0+(2)#2 – 600 kcmil	Cu/Al	3	OZXA-32	

### Auxiliary contacts

Description	For use on:	AC thermal amp rating	AC rated voltage	Catalog number <sup>①</sup>	List price
1 N.O. 1 N.C. Module for aux. contacts	OT200-1200	10	600	OA1G10	
		10	600	OA3G01	
		10	600	OEA28	
1 N.O. + 1 N.C. 2 N.O. + 2 N.C. 4 N.O. + 4 N.C.	OETL-NF1600 & OETL-NF2000	10	600	OZXK-1	
		10	600	OZXK-2	
		10	600	OZXK-3	

① Mounting on the side of the switch: max. 8 auxiliary contact blocks with the OEA28 module

Mounting under the mechanism cover: OT200: Max. 4 test contacts or 2 test contacts + 2 test indication contacts.

OT400-600: Max. 4 test contacts + 4 test indication contacts. OT800-1200: Max 4 test indication contacts + 8 test contacts. The test contacts can be used as standard auxiliary contacts as well.

### Detachable neutral links

Description	For use on:	AC thermal amp rating	AC rated voltage	Catalog number	List price
Mounting separately on baseplate protected construction	OT200	200	600	OXN250	
	OT400	400	600	OXN400	
	OT600	600	600	OXN800T	

### Terminal shrouds (Snap-on mounting, grey plastic, IP30) ② For both line and load sides

For use on:	Lug type	Qty per pkg	Quantity for full protection (pcs.) <sup>②</sup>	Catalog number	List price
OT200U03	OZXA-200	3 x 1P	2	OTS250G1L/3	
OT200U12	OZXA-200	3 x 1P	2	OTS250G1L/3	
OT400U03	OZXA-400	1 x 3P	2	OTS403	
OT400U03	OZXA-402	1 x 3P	2	OTS403	
OT400U03	OZXA-33	3 x 1P	2	OETL-ZX94	
OT600U03	OZXA-800	3 x 1P	2	OTS603	
OT800 -1200	OZXA-800	3 x 1P	2	OTS1600G1L/3	
OT800 -1200	OZXA-1200	3 x 1P	2	OTS1600G1L/3	

### Shaft extension coupler

Description	For use on:	Catalog number	List price
Joins two shafts together for applications where extended length is required	6mm shafts	OESA-ZX167	
	12mm shafts	OETL-ZX95	

### Mounting feet

Description	For use on:	Catalog number	List price
Mounting feet Screw	OT200	OEZKL1 FPMH3.5X12X-TX15	
Mounting feet Screw	OS200/400, OT400/600	OEZKL2 FPMH5X14X-TORX	
Mounting feet	OT800	OZXE14	



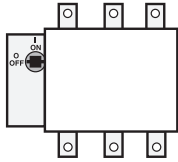

# Accessories for 400- 1200A Non-fusible disconnect switches

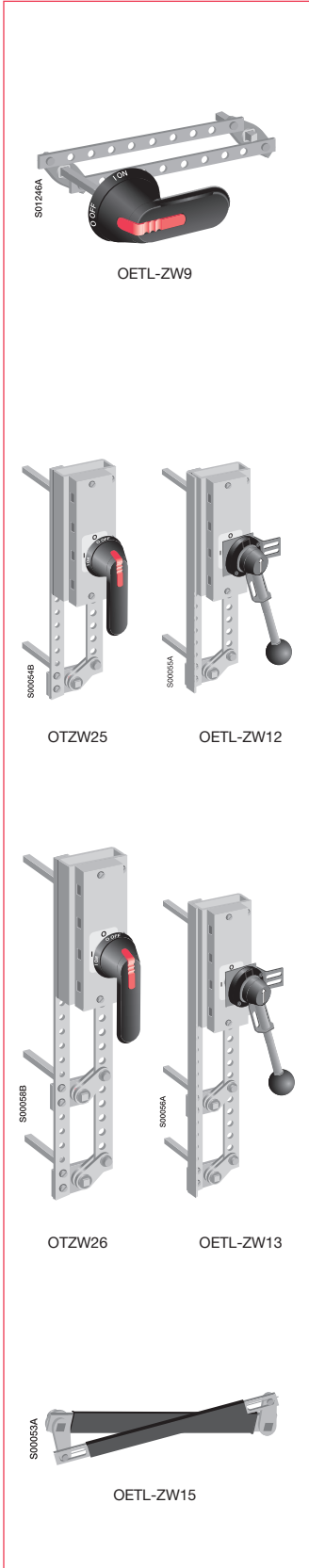

### Conversion mechanisms

- For use with Base and Din rail mounted switches only
- Switches are not included

Description	For use on:	Catalog number	List price
6 or 8 pole Transfer Bypass	OT400, OT600	OETL-ZW9 OETL-ZW12 OETL-ZW13	
Mechanical interlock	OT400, OT1200	OETL-ZW15	

Conversion kit type	To be ordered separately		Included in conversion kit delivery		The standard handle or shaft of one of the combined switches can be used	
	Shaft	Handle	Shaft	Handle	Shaft	Handle
<b>6 and 8-pole switches</b>						
OETL-ZW9 for OT	-	-	-	-	x	x
OETL-ZW9 for OETL	-	YASDA7	-	-	x	-
<b>Change-over switches</b>						
OETL-ZW12	-	-	x (2 pcs)	YASDA21 (metallic)	-	-
<b>By-pass switches</b>						
OETL-ZW13	-	-	x (3 pcs)	YASDA6	-	-
<b>Mechanical interlock</b>						
OETL-ZW15	-	-	-	-	x	x

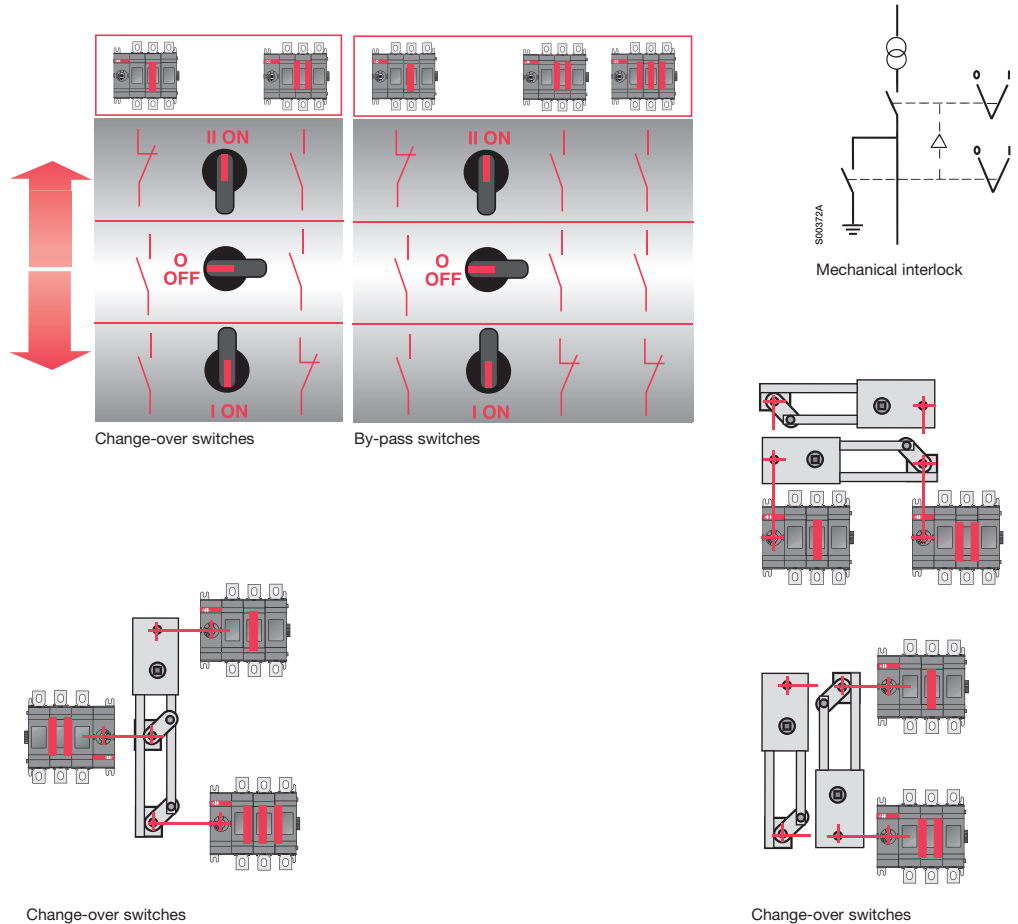



## Accessories for 200- 1200A Non-fusible disconnect switches

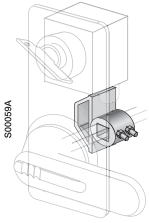

500059A

OETL-ZW5

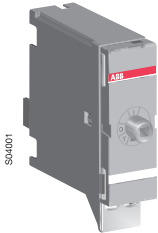

504401

OTZT1



504403

OTZT3



OTZC\_

### Locking accessories

Description	For use on:	Catalog number	List price
<b>Cam attachment for Kirk Key, interlock.</b> For adapting to the interlock system The interlock is not included.	12mm shafts	OETL-ZW5	

### Phase separators

Description	For use on:	Catalog number	List price
Grey plastic plate for maintaining 1" clearance between the phases without terminal shrouds. Snap-on mounting. The package includes 6 plates.	OT600 OT800-OT1200	OTB800/6 OTB1600/6	

### Mechanism interlock kits & Electrical interlocks

Non-fusible disconnect switches 200A- 1200A can be interlocked in the OFF position using padlocks and by using a mechanical interlock kit mounted on the mechanism. The diameter of the lock ball can be max dia. 8 mm.

Description	For use on:	Catalog number	List price
Interlocking in the OFF position	OT200 OT400 OT600 OT800-1200	OTZT1A OTZT2A OTZT3A OTZT4A	
Interlocking in the OFF & ON positions	OT200 OT400 OT600 OT800-1200	OTZT1L OTZT2L OTZT3L OTZT4L	

### Bridging bars

The bridging bars provide a connection link either on the incoming or outgoing side of the switch.

Suitable for switches	Number of poles	Catalog number	List price
OT200U_C	3	OTZC13	
	4	OTZC14	
OT400U_C	3	OTZC23	
	4	OTZC24	
OT600U_C	3	OTZC33	
	4	OTZC34	
OT800U_C	3	OTZC43	
	4	OTZC44	

- ① Mounting depth is the distance from the outside of the door to the disconnect switch mounting plate. Shaft can be cut to desired length.  
② Plastic pistol grip handle with stainless steel hasp, add suffix EH

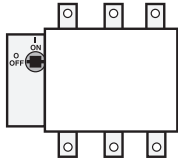

## Other configurations

### Side operated

### 30A – 800A



For a complete assembly,  
please select one of each:

- 1 switch
- 1 handle
- 1 shaft
- 1 terminal lug kit

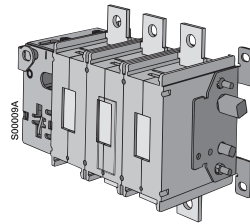

OETL-NF200A-S

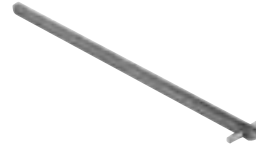

OXP8X240



OHB80J8TE00S



OSNF30-S



OHY\_J\_

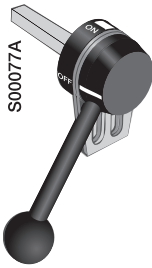

OETL-ZX74



OXP5X170  
OXP8X240  
OXP12X325



OZXA-24



OZXA-25



OZXA-26



OZXA-27

### Side operated switches — 3 pole

CSA general purpose amp rating	IEC AC21 amp rating	Maximum horsepower rating					Catalog number	List price
		Three phase						
		200V	208V	240V	480V	600V		
30	32	5	7.5	7.5	15	20	OSNF30-S	
60	63	15	15	15	30	50	OSNF60-S	
100	125	25	25	30	60	75	OSNF100-S	
200	250	60	60	75	150	200	OETL-NF200A-S	
400	630	100	100	125	250	350	OETL-NF400-S	
600	800	150	150	200	400	500	OETL-NF600A-S	

### Handles

UL/NEMA type	Color	Length mm	Marking	Defeatable	Padlockable	Catalog number	List price
<b>For use with OSNF30-S</b>							
1, 12, 3R	Black	65	O/I & OFF/ON	Yes	Yes	OHB65J6	
1, 12, 3R	Red/Yel	65	O/I & OFF/ON	Yes	Yes	OHY65J6	
<b>For use with OSNF60-S — OSNF100-S</b>							
1, 12, 3R	Black	80	O/I & OFF/ON	Yes	Yes	OHB80J6	
1, 12, 3R	Red/Yel	80	O/I & OFF/ON	Yes	Yes	OHY80J6	
<b>For use with OETL-NF200A-S</b>							
1, 12, 3R	Black	80	O/I & OFF/ON	Yes	Yes	OHB80J8	
1, 12, 3R	Red/Yel	80	O/I & OFF/ON	Yes	Yes	OHY80J8	
<b>For use with OETL-400-S — OETL-NF600A-S</b>							
1, 12, 3R	Black	145	O/I & OFF/ON	Yes	Yes	OHB145J12	
1, 12, 3R	Red/Yel	145	O/I & OFF/ON	Yes	Yes	OHY145J12	
1, 12, 3R	Metal	145	OFF/ON	Yes	Yes	OETL-ZX74	

### Shafts

For use on :	Length mm	Description	Catalog number	List price
OSNF30-S	170	6 x 6mm	OXP6X170	
OSNF60-S – OSNF100-S	210	6 x 6mm	OXP6X210	
OETL-NF200A-S	240	8 x 8mm	OXP8X240	
OETL-NF400-S – OETL-NF600A-S	325	12 X 12mm	OXP12X325	

### Terminal lug kits

For use on:	Wire size	Weight	Wire type	Lugs per kit	Catalog number	List price
OSNF30-S	#18 – 8	—	Cu	—	Integral	
OSNF60-S	#14 – 4	—	Cu	—	Integral	
OSNF100-S	#14 – 2/0	0.43	Cu/Al	6	OZXA-24	
OETL-NF200A-S	#6 – 300 kcmil	0.93	Cu/Al	6	OZXA-25	
OETL-NF400-S	#2 – 600 kcmil	3.520	Cu/Al	6	OZXA-26	
OETL-NF600A-S	(2) #2 – 600 kcmil	4.62	Cu/Al	6	OZXA-27	



## Other configurations

### Flange operated disconnect switches

### Cable operated non-fusible

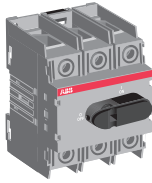

OT100F3



Switch



Handle



Cable



Lug kit (as required)



Operating mechanism



OHF1C12



OXC1L36



Operating mechanism

### Flange operated switches 30A- 200A – 3 pole

CSA general purpose amp rating	Maximum horsepower rating					Catalog number	List price
	Three phase						
	200V	208V	240V	480V	600V		
30	10	10	10	20	30	OT30F3	
60	20	20	20	40	40	OT60F3	
100	25	25	30	50	50	OT100E3	
125	30	30	40	75	100	OT160E3	
200	60	60	75	150	200	OT200U30	

### Operating mechanisms

For use with:	Catalog number	List price
OT30-100 OT160 OT200	MKCS1 MKCS3 MKCS4	

### Handles

CSA/NEMA type	Color	Lenght (mm)	Marking	Defeatable	Padlockable	Catalog number	List price
1, 3R, 12	Metal	175	O/I & Off/On	Yes	Yes	OHF1C12	
4, 4X	Metal	175	O/I & Off/On	Yes	Yes	OHF1C4	

### Cable

For use with:	Cable length (inches)	Catalog number	List price
OT30_ - OT400_	36	OXC1L36	
	48	OXC1L48	
	60	OXC1L60	
	72	OXC1L72	
	84	OXC1L84	
	96	OXC1L96	
	108	OXC1L108	

### Door hardware NEMA 12

Description	Catalog number	List price
Safety door latch, 2 point, door less than 40" high	KDH2R	
Safety door latch, 3 point, door less than 40" high	KDH3R	

① Terminal lug kits are on page 1.21



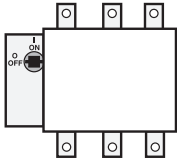

# CSA & UL Technical data for Non-fusible disconnect switches OT16F3 – OT160F3



## CSA & UL

Catalog number	3 pole	OT16F3	OT25F3	OT40F3	OT63F3	OT80F3	OT30F3	OT60F3	OT100F3	OT160E3
*Approvals <sup>①</sup>	2 pole 3 pole 4 pole	N/A CSA C22.2 No.14 CSA C22.2 No.14	N/A CSA C22.2 No.14 CSA C22.2 No.14	N/A CSA C22.2 No.14 CSA C22.2 No.14	N/A CSA C22.2 No.14 CSA C22.2 No.14	N/A CSA C22.2 No.14 CSA C22.2 No.14	N/A CSA C22.2 No.4 CSA C22.2 No.4	N/A CSA C22.2 No.4 CSA C22.2 No.4	N/A CSA C22.2 No.4 CSA C22.2 No.4	N/A CSA C22.2 No.4 CSA C22.2 No.4
<b>General purpose amp rating</b> -40°C to 40°C pf = 0.7 – 0.8	<b>A</b>	<b>16</b>	<b>25</b>	<b>40</b>	<b>60</b>	<b>80</b>	<b>30</b>	<b>60</b>	<b>100</b>	<b>125</b>
Max. operating voltage	V	600	600	600	600	600	600	600	600	600
<b>Max. horsepower rating/motor FLA current,</b> pf = 0.4 – 0.5										
Three phase	208V HP/A	3/10.6	7.5/24.2	10/31	15/46	20/60	10/31	20/60	25/75	30/88
	240V HP/A	5/15.2	7.5/22	10/28	15/42	20/54	10/28	20/54	30/80	40/104
	480V HP/A	10/14	15/21	20/27	30/40	40/52	20/27	40/52	50/65	75/96
	600V HP/A	15/11	20/22	25/27	30/32	40/41	30/32	40/41	50/52	100/99
Single phase	120V HP/A	1/16	1.5/20	2/24	2/24	2/24	2/24	3/34	5/56	7.5/80
	240V HP/A	2/13	3/19	5/31	7.5/40	10/58	5/31	7.5/40	15/68	20/88
<b>Short circuit rating with fuse</b>										
Fuse type CC	kA	10	10	10	—	—	—	—	—	—
Fuse type J	kA	10 10	10 10	10 10	100	—	100	—	50	100
Fuse type T	kA	10 10	10 10	10 10	100	—	100	—	50	—
Fuse type RK1	kA	10	—	10	—	—	—	—	—	—
Fuse type RK5	kA	5 5	5 5	5 5	10 5	—	10 5	—	—	—
Fuse type L	kA	—	—	—	—	—	—	—	—	—
Fuse type H	kA	—	—	—	—	5	—	5	—	—
Fuse size	A	30 60	30 60	30 60	100 150	—	100 150	—	60	150 200
Short circuit rating with MCCB	kA	—	—	—	—	—	—	—	—	25
<b>Endurances</b>										
Min. Electrical endurance, pf = 0.75 – 0.80 operation cycles		6000	6000	6000	6000	6000	6000	6000	6000	6000
Min. Electrical endurance, pf = 0.40 – 0.50 operation cycles		1000	1000	1000	1000	1000	1000	②	②	③
Mechanical endurance operations		20,000	20,000	20,000	20,000	20,000	20,000	20,000	20,000	16,000
<b>Physical characteristics</b>										
Weight, switches 3 pole	Kg	0.11	0.11	0.11	0.27	0.27	0.36	0.36	0.36	1.1
4 pole	Kg	0.15	0.15	0.15	0.35	0.35	0.5	0.5	0.5	1.3
Dimension, switches 3 pole	H mm	68	68	68	91	91	100	100	100	127
	W mm	35	35	35	53	53	70	70	70	126
	D mm	56	56	56	72	72	75	75	75	74
Shaft size — square □	mm	6 x 6	6 x 6	6 x 6	6 x 6	6 x 6	6 x 6	6 x 6	6 x 6	6 x 6
Switch operating torque for rotary 3 pole switches	lb. in.	8.8	8.8	8.8	10.5	10.5	17.5	17.5	17.5	52.5
<b>Terminal lug kits</b>										
Wire range	AWG	Not required #18 – #8	Not required #18 – #8	Not required #18 – #8	Not required #14 – #1	Not required #14 – #1	Not required #14 – #4	Not required #14 – #4	Not required #8 – 1/0	Not required #8 – 1/0
Torque:										
Wire tightening	lb. in.	7	7	7	18	18	55	55	55	70
Lug mounting	lb. in.	Integral	Integral	Integral	Integral	Integral	Integral	Integral	Integral	Integral
<b>Auxiliary contacts</b>										
NEMA ratings, AC		OA1G_ _ A600	OA1G_ _ A600	OA1G_ _ A600	OA1G_ _ A600	OA1G_ _ A600	OA1G_ _ A600	OA1G_ _ A600	OA1G_ _ A600	OBEA_ _ A600
AC rated voltage	VAC	600	600	600	600	600	600	600	600	600
AC thermal rated current	A	10	10	10	10	10	10	10	10	10
AC maximum volt-ampere making	VA	7200	7200	7200	7200	7200	7200	7200	7200	7200
AC maximum volt-ampere breaking	VA	720	720	720	720	720	720	720	720	720
NEMA ratings, DC		R300	R300	R300	R300	R300	R300	R300	R300	P600
DC rated voltage	VDC	300	300	300	300	300	300	300	300	600
DC thermal rated current	A	1	1	1	1	1	1	1	1	5
DC maximum make-break	VA	28	28	28	28	28	28	28	25	138
Torque:										
Wire tightening	lb. in.	7	7	7	7	7	7	7	7	7
Wire range	AWG	#18 – #14	#18 – #14	#18 – #14	#18 – #14	#18 – #14	#18 – #14	#18 – #14	#18 – #14	#18 – #14

① CSA Approved switches are also UL Listed.  
② UL98 overload test, 50 operations, pf 0.40 – 0.50 at 2x FLA.



# CSA & UL Technical data for Non-fusible disconnect switches OT200U03 – OETL-NF2000

## CSA & UL

Catalog number	3 pole	OT200U03	OT400U03	OT600U03	OT800U03	OT1200U03	OETL-NF1600	OETL-NF2000
Approvals <sup>①</sup>	2 pole 3 pole 4 pole	CSA C22.2 No.4 CSA C22.2 No.4 CSA C22.2 No.4	CSA C22.2 No.4 CSA C22.2 No.4 CSA C22.2 No.4	CSA C22.2 No.4 CSA C22.2 No.4 CSA C22.2 No.4	CSA C22.2 No.4 CSA C22.2 No.4 CSA C22.2 No.4	CSA C22.2 No.4 CSA C22.2 No.4 CSA C22.2 No.4	CSA C22.2 No.4 CSA C22.2 No.4 IEC	CSA C22.2 No.4 CSA C22.2 No.4 IEC
General purpose amp rating pf = 0.7 – 0.8	40°C <b>A</b>	<b>200</b>	<b>400</b>	<b>600</b>	<b>800</b>	<b>1200</b>	<b>1600</b>	<b>2000</b>
Max. operating voltage	V	600	600	600	600	600	600	480
Max. horsepower rating/Max. motor FLA current, pf = 0.4 – 0.5								
Three phase	208V HP/A 240V HP/A 480V HP/A 600V HP/A	60/178 75/192 150/180 200/192	100/286 125/312 250/302 350/336	150/416 200/480 450/515 500/472	200/528 250/602 500/590 500/576	— — — —	— — — —	— — — —
Single phase	120V HP/A 240V HP/A	— —	— —	— —	— —	— —	— —	— —
Short circuit rating with fuse								
Fuse type CC	kA	—	—	—	—	—	—	—
Fuse type J	kA	100 65	100	100	—	—	—	—
Fuse type T	kA	—	—	100	—	—	—	—
Fuse type RK1	kA	—	—	—	—	—	—	—
Fuse type RK5	kA	—	—	—	—	—	—	—
Fuse type L	kA	—	—	100	100	100	100	100
Fuse type H	kA	—	—	—	—	—	—	—
Fuse size	A	200 400	600	800	1200	1200	2000	2000
Short circuit rating with MCCB	kA	15	30	50	50	50	65	65
Endurances								
Min. Electrical endurance, pf = 0.75 – 0.80	operation cycles	6000	1000	1000	500	500	500	500
Min. Electrical endurance, pf = 0.40 – 0.50	operation cycles	②	②	②	②	②	②	②
Mechanical endurance	operations	20,000	16,000	10,000	6000	6000	6000	1200
Physical characteristics								
Weight, switches	3 pole Kg 4 pole Kg	1.2 1.5	2.2 2.8	5.2 6.5	15.2 19.5	15.2 22	37 68	37 68
Dimension, switches	3 pole H mm W mm D mm	170 170 84	220 221 105	250 266 139	372 334 141	372 334 141	636 468 271	636 468 271
Shaft size — square	mm	6 x 6	12 x 12	12 x 12	12 x 12	12 x 12	12 x 12	12 x 12
Switch operating torque for rotary 3 pole switches	lb. in.	62	142	184	184	184	438	438
Terminal lug kits		OZXA-200	OZXA-400	OZXA-800	OZXA-1200	OZXA-1200	OZXA-28	OZXA-28/2
Wire range	AWG	#4-300kcmil <sup>③</sup>	#2-600kcmil	(2)#2-600kcmil	(4)#2-600kcmil	(4)#2-600kcmil	(4)#2-600kcmil	(8)#2-600kcmil
Torque:								
Wire tightening	lb. in.	200	375	375	375	375	375	375
Lug mounting	lb. in.	75	240	240	240	240	230	230
Auxiliary contacts		OA1G-__	OA1G-__	OA1G-__	OA1G-__	OA1G-__	OZ XK-__	OZ XK-__
NEMA ratings, AC		A600	A600	A600	A600	A600	A600	A600
AC rated voltage	VAC	600	600	600	600	600	600	600
AC thermal rated current	A	10	10	10	10	10	10	10
AC maximum volt-ampere making	VA	7200	7200	7200	7200	7200	7200	7200
AC maximum volt-ampere breaking	VA	720	720	720	720	720	720	720
NEMA ratings, DC		P600	P600	P600	P600	P600	P600	P600
DC rated voltage	VDC	600	600	600	600	600	600	600
DC thermal rated current	A	5	5	5	5	5	5	5
DC maximum make-break	VA	138	138	138	138	138	138	138
Torque:								
Wire tightening	lb. in.	7	7	7	7	7	7	7
Wire range	AWG	#22 – #14	#22 – #14	#22 – #14	#22 – #14	#22 – #14	#22 – #14	#22 – #14

① CSA Approved switches are also UL Listed.

② CSA 22.2 No. 4 overload test, 50 operations, pf 0.40 – 0.50 at 2x FLA.

③ Multi-tap lug available, please see pg. 1.21.

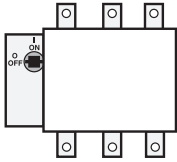

## IEC Technical data for Non-fusible disconnect switches OT16F3 – OT160F3



### IEC

Catalog number		3 pole	OT16F3	OT25F3	OT40F3	OT63F3	OT80F3	OT100F3	OT160E3
Rated insulation and operational voltage, AC20 and DC20		40°C V	750	750	750	750	750	750	750
Rated impulse withstand voltage		kV	8	8	8	8	8	8	12
Rated thermal current, I <sub>th</sub>									
AC 20/DC 20	open	A	25	32	40	63	80	115	200
	40°C enclosed	A	25	32	40	63	80	115	160
	60°C enclosed	A	25	32	40	63	80	115	160
Rated operational currents									
AC-22A	Up to 415 V	A	16	25	40	63	80	100	160
	440 - 500 V	A	16	25	40	63	80	100	160
	690 V	A	16	25	40	63	80	100	160
AC-23A	Up to 415 V	A	16	20	23	45	75	80	135
	440 - 500 V	A	16	20	23	45	58	60	125
	690 V	A	10	11	12	20	20	40	80
Rated operational currents/poles in series									
DC21A	48V	A	16/1	25/1	32/1	45/1	63/1	100/1	160/1
	110V	A	16/2	25/2	32/2	45/2	63/2	100/2	160/1
	220V	A	16/3	25/3	32/3	45/4	63/4	100/4	160/2
	440V	A	16/4	25/6	32/6	—	—	—	160/3
	750V	A	16/8	25/8	32/8	—	—	—	160/4
DC22A	48V	A	16/1	25/1	32/1	45/1	63/1	100/1	160/1
	110V	A	16/2	25/2	32/2	45/2	63/2	100/2	160/1
	220V	A	16/3	25/3	32/4	45/4	63/4	100/2	160/2
	440V	A	16/6	25/6	—	—	—	—	160/3
	750V	A	16/8	25/8	—	—	—	—	—
DC23A	48V	A	16/1	25/1	32/1	45/1	63/1	100/1	160/1
	110V	A	16/2	25/2	32/2	45/2	63/2	100/2	160/1
	220V	A	16/4	25/4	32/4	45/4	63/4	100/2	160/2
	440V	A	10/4	10/4	10/4	10/4	10/4	—	160/3
	750V	A	16/8	—	16/8	16/8	—	—	—
Rated operational power									
AC23A	230V	kW	3	4	5.5	11	22	22	45
	400/415V	kW	7.5	9	11	22	37	37	75
	500V	kW	7.5	9	11	22	37	37	75
	690V	kW	7.5	9	11	15	18.5	37	75
Short-circuit current		kA	50	50	50	50	50	50	100
with back-up fuses of size		A	25	32	40	63	80	100	200
Rated short-circuit making capacity, prospective peak value, I <sub>CM</sub> 690V		kA	0.7	0.7	0.7	1.4	2.1	3.6	12
Rated short time withstand current,									
RMS I <sub>CW</sub>	0.2s	kA	—	—	—	—	—	—	7
RMS I <sub>CW</sub>	1.0s	kA	0.5	0.5	0.5	1	1.5	2.5	4
AC breaking capacity									
pf = 0.35	≤415V	A	128	160	184	240	304	640	1080
	≤500V	A	128	160	184	240	256	480	1000
	≤690V	A	80	88	96	160	160	320	640
DC breaking capacity/poles in series									
L/R = 15ms	≤48V	A	64/1	100/1	128/1	180/1	252/1	400/1	640/1
	≤110V	A	64/2	100/2	128/2	180/2	180/2	400/2	640/1
	≤220V	A	64/3	100/4	128/4	180/4	180/4	252/4	640/2
	≤440V	A	40/4	40/4	40/4	40/4	40/4	—	640/3
	≤750V	A	64/8	64/8	64/8	—	—	—	—





## IEC Technical data

### for Non-fusible disconnect switches

### OT200 – OETL-NF2000

#### IEC

Catalog number	3 pole	OT200U03	OT400U03	OT600U03	OT800U03	OT1200U03	OETL-NF1600	OETL-NF2000
Rated insulation and operational voltage, AC20 and DC20	40°C V	1000	1000	1000	1000	1000	1000	1000
Rated impulse withstand voltage	kV	12	12	12	12	12	8	8
Rated thermal current, I <sub>th</sub>								
AC 20/DC 20	open A	250	400	800	1250	1600	2500	3150
	40°C enclosed A	250	400	800	1250	1600	2300	2300
	60°C enclosed A	—	—	—	1000	1250	1950	1950
Rated operational currents								
AC 22A	Up to 415 V A	250	400	800	1000	1600	2500	2500
	440 - 500 V A	250	400	800	1000	1600	2500	2500
	690 V A	250	400	800	800	1250	—	—
AC 23A	Up to 415 V A	250	400	800	800	1000	1600	1600
	440 - 500 V A	250	400	800	800	1000	—	—
	690 V A	250	400	800	650	650	—	—
Rated operational currents								
DC21A	48V A	250/1	400/2	800/2	—	—	2500/2	2500/2
	110V A	250/2	400/2	800/2	—	—	2500/2	2500/2
	220V A	250/2	400/2	800/2	—	—	2500/2	2500/2
	440V A	250/3	400/3	800/3	—	—	2500/3	2500/3
	750V A	250/4	—	—	—	—	—	—
DC22A	48V A	250/1	400/2	800/2	—	—	2500/2	2500/2
	110V A	250/2	400/2	800/2	—	—	2500/2	2500/2
	220V A	250/2	400/2	800/2	—	—	2500/2	2500/2
	440V A	250/3	400/3	800/3	—	—	—	—
	750V A	250/4	—	—	—	—	—	—
DC23A	48V A	250/1	630/2	—	—	—	—	—
	110V A	250/2	630/2	—	—	—	—	—
	220V A	250/2	630/2	—	—	—	—	—
	440V A	250/3	—	—	—	—	—	—
	750V A	250/4	—	—	—	—	—	—
Rated operational power								
AC23A	230V kW	75	110	—	—	250	250	250
	400/415V kW	132	220	450	560	400	400	400
	500V kW	170	280	560	710	450	450	450
	690V kW	240	390	800	800	—	—	—
Short-circuit current	kA	100	100	100	50	50	50	50
with back-up fuses of size	A	355	500	800	1000	1250	1600	2000
Rated short-circuit making capacity, prospective peak value, I <sub>cm</sub> 690V	kA	30	65	80	110	110	105	105
Rated short time withstand current,								
RMS I <sub>cw</sub>	0.2s kA	15	24	36	50	56	—	—
RMS I <sub>cw</sub>	1.0s kA	8	15	20	50	50	80	80
AC breaking capacity								
pf = 0.35	≤415V A	2000	3200	5760	10000	10000	6400	6400
	≤500V A	2000	3200	5600	10000	10000	6400	6400
	≤690V A	2000	3200	5600	6400	6400	4800	4800
DC breaking capacity								
	48V A	1000/2	—	—	—	—	—	—
	110V A	1000/2	—	—	—	—	—	—
	220V A	1000/2	1600/2	2000/2	1900/2	2600/2	2600/2	2600/2
	440V A	1000/3	1600/3	2000/3	—	—	—	—
	750V A	1000/4	—	—	—	—	—	—

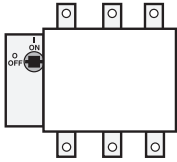

## Selecting switches per CEC & IEC



### Selecting switches per CEC

Section 28 of the Canadian Electric Code includes two methods for properly sizing disconnect switches:

#### 1. Single motor application

A properly sized disconnect switch for a single motor will:

- have an ampere rating greater than or equal to 115 percent of the rated motor full load current; or,
- have a HP rating greater than or equal to the rated motor HP (at applied voltage) if the disconnect switch under consideration is HP rated.

#### 2. Combination load application

A properly sized disconnect switch for a combination load will be selected by adding all the simultaneous individual loads in the circuit under consideration.

Using motor nameplate information, load information, and tables from section 28 of the CEC, determine one equivalent full load current and plus 15% of the largest motor determine an equivalent HP rating. Select a disconnect switch:

- greater than or equal to 115 percent of the equivalent full load current; and,
- greater than or equal to the equivalent HP rating.

### Selecting switches per IEC

#### Utilization categories

Nature of current	Utilization category		Typical applications
	Frequent operation	Infrequent operation	
Alternating current	AC-20A	AC-20B	<ul style="list-style-type: none"> <li>Connecting and disconnecting under no-load conditions</li> <li>Switching of resistive loads including moderate overloads (PF &gt; 0.95)</li> <li>Switching of mixed resistive and inductive loads, including moderate overloads (PF &gt; 0.65)</li> <li>Switching of motor loads or other highly inductive loads (PF &gt; 0.45 below 100A; PF &gt; 0.35 above 100A)</li> </ul>
	AC-21A	AC-21B	
	AC-22A	AC-22B	
	AC-23A	AC-23B	
Direct current	DC-20A	DC-20B	<ul style="list-style-type: none"> <li>Connecting and disconnecting under no-load conditions</li> <li>Switching of resistive loads including moderate overloads (L/R &lt; 1ms)</li> <li>Switching of mixed resistive and inductive loads, including moderate overloads e.g., shunt motors (L/R &lt; 2.5ms)</li> <li>Switching of highly inductive loads e.g., series motors (L/R &lt; 15ms)</li> </ul>
	DC-21A	DC-21B	
	DC-22A	DC-22B	
	DC-23A	DC-23B	
Mechanical endurance	Number of operations	Number of operations	
100A	10,000	2000	
315A	8000	1600	
>315A	2000	400	

•Category AC-23 includes occasional switching of individual motors. The switching of capacitors of tungsten filament lamps shall be subject to agreement between manufacturer and user.



## Use of CSA C22.2 No. 4 & No. 14 Disconnects According to CEC<sup>®</sup> Section 28

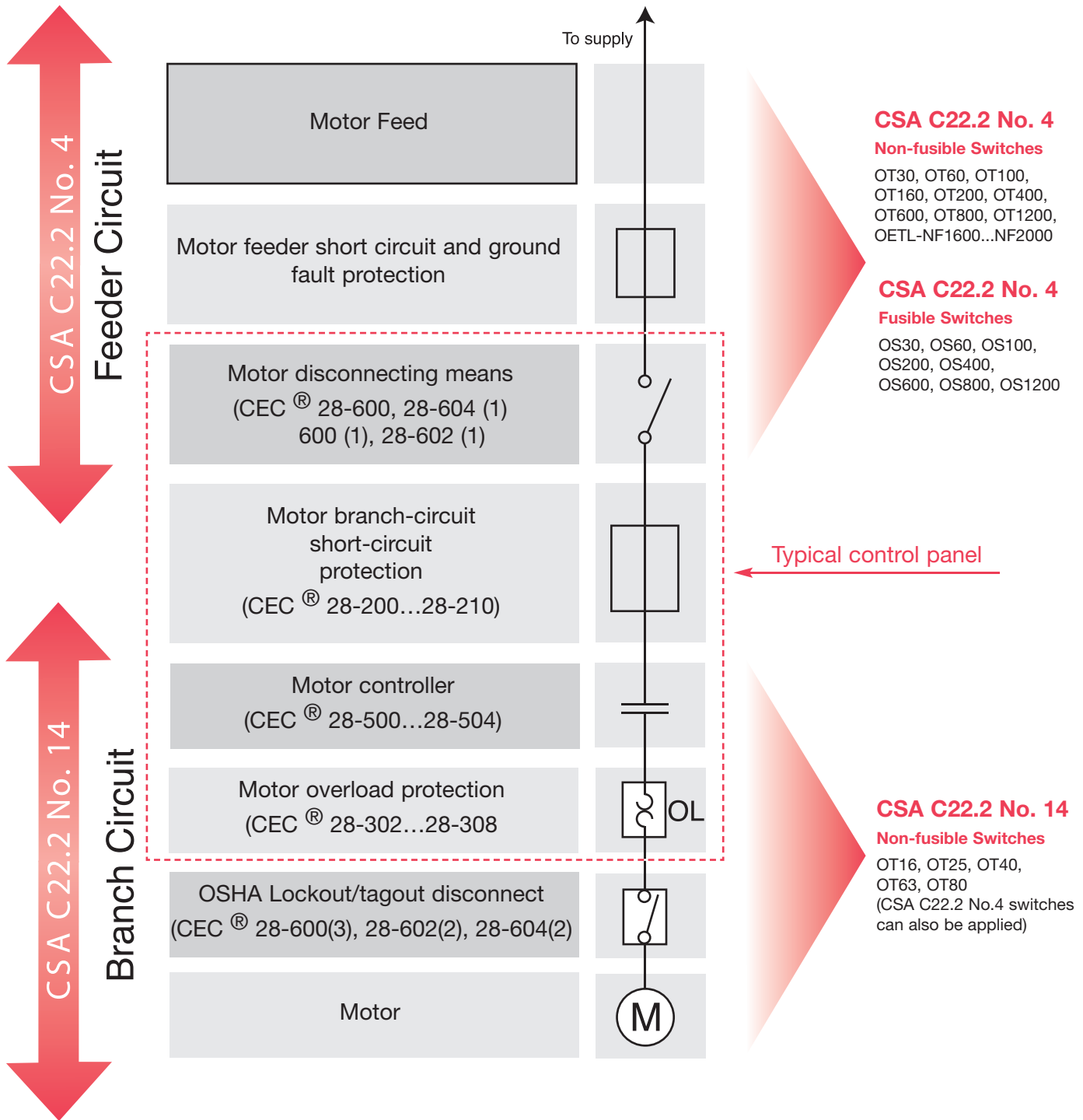

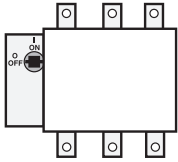

## Auxiliary contact timing diagrams OT16 – OT160



### Handle indications and functions

- The handle indicates the position of the contacts with complete reliability in all situations.  
If the contacts are welded together, the handle doesn't reach the OFF-position but remains between ON and OFF, maintaining the door interlock and padlocking is not possible to do.
- When operating the switch to the Test-position with a test handle the auxiliary contacts change position. The main contacts remain open.

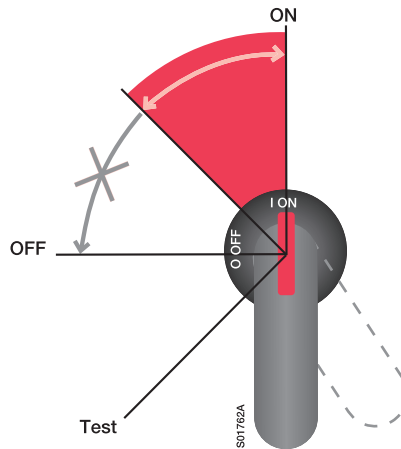

### ON and OFF-functions of main and auxiliary contacts

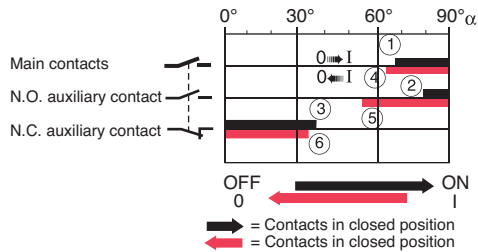

#### Contacts closing

- ① Main contacts close
- ② N.O. auxiliary contacts close
- ③ N.C. auxiliary contacts open

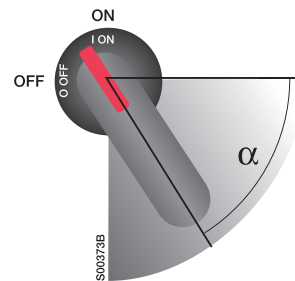

#### Contacts opening

- ④ Main contacts open
- ⑤ N.O. auxiliary contacts open
- ⑥ N.C. auxiliary contacts close

### OT16, OT25, OT40

Catalog number	Auxiliary contact	Contact configuration
OT16, OT25, OT40	OA1G10 OA1G01 OA2G11	1 N.O. 1 N.C. 1 N.O. & 1 N.C.

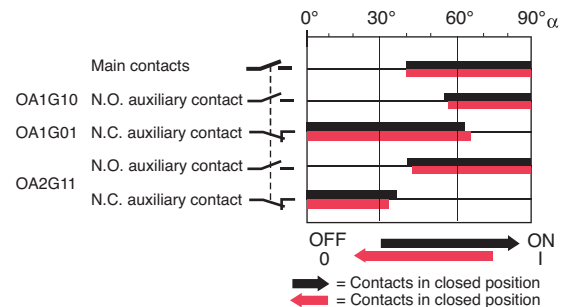



## Auxiliary contact timing diagrams for Non-fusible disconnect switches OT200 - OETL-NF2000

### OT63, OT80, OT30, OT60, OT100

Catalog number	Auxiliary contact	Contact configuration
OT63, OT80 OT30, OT60, OT100	OA1G10 OA1G01 OA2G11	1 N.O. 1 N.C. 1 N.O. & 1 N.C.

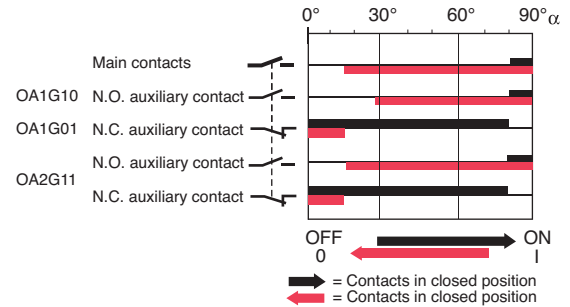

### OT160

Catalog number	Auxiliary contact	Contact configuration
OT160	OBEA10 OBEA01	1 N.O. 1 N.C.

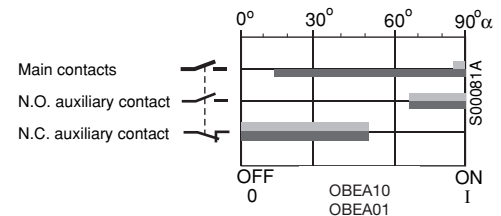

### OT200U03 – OT1200U03

Catalog number	Auxiliary contact	Contact configuration
OT200U03 – OT1200U03	OA1G10 OA3G01	1 N.O. 1 N.C.

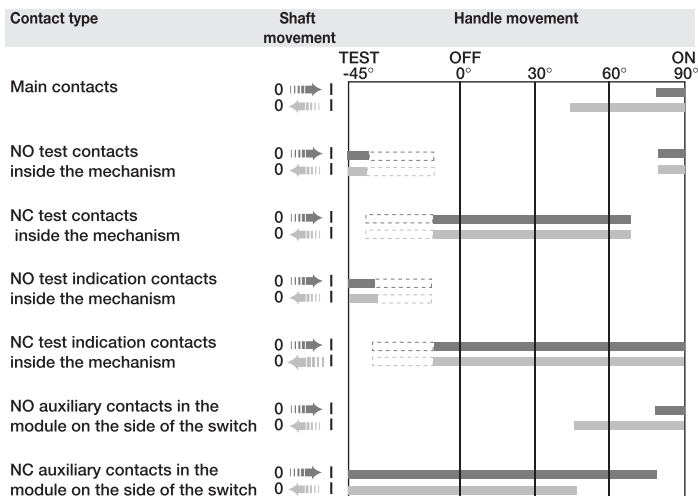

### OETL-NF1600 – OETL-NF2000

Catalog number	Auxiliary contact	Contact configuration
OETL-NF1600 – OETL-NF2000	OZXK-1 OZXK-2 OZXK-3	1 N.O. & 1 N.C. 2 N.O. & 2 N.C. 4 N.O. & 4 N.C.

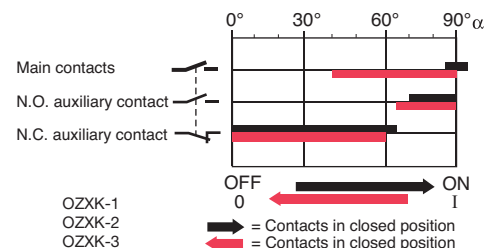

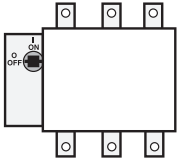

## Approximate dimensions

### Non-fusible disconnect switches

### OT16 – OT40



#### OT16F3 – OT40F3 — base & DIN rail mounted switch

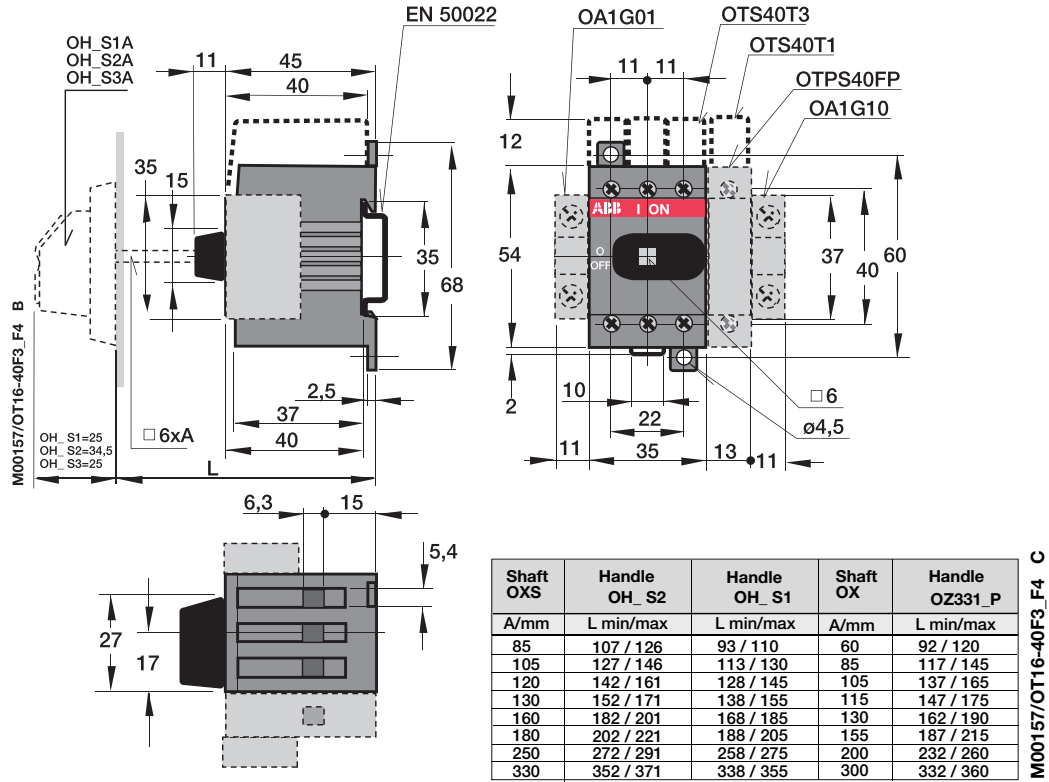

#### OT16FT3 – OT40FT3 — door mounted switch

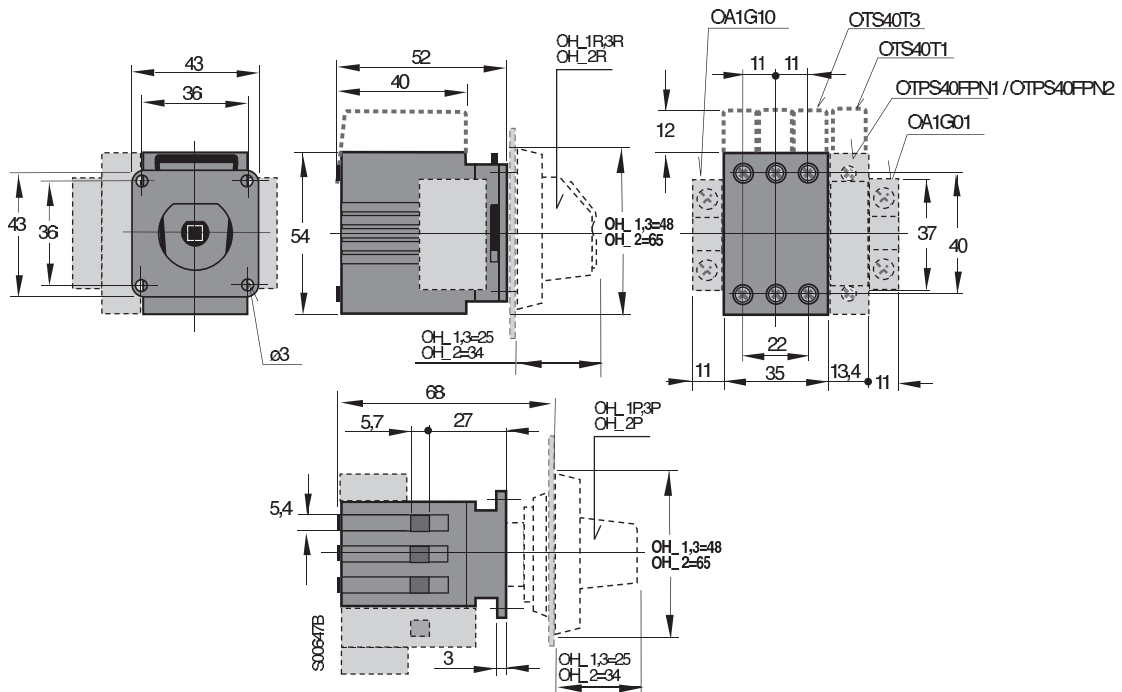

#### OT63F3 – OT80F3 — base & DIN rail mounted switch

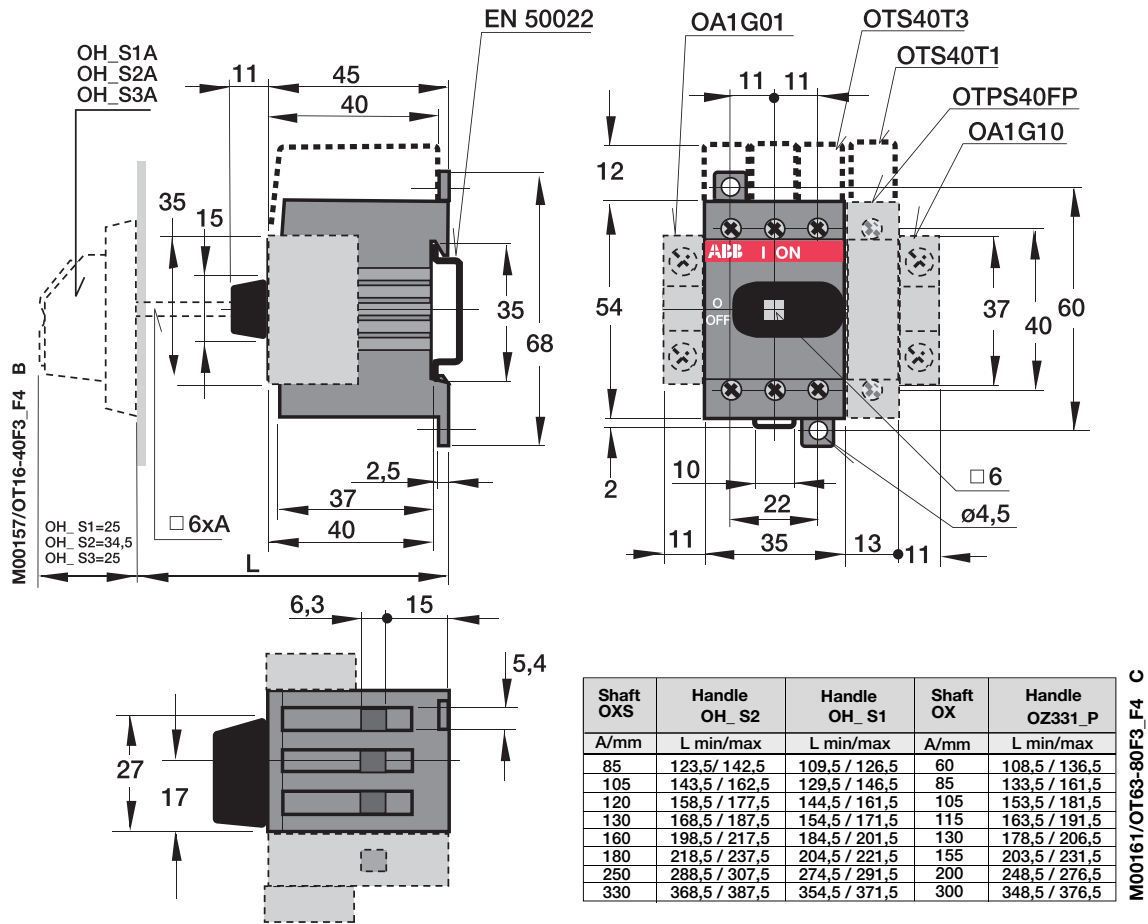

#### OT63FT3 – OT80FT3 – door mounted switch

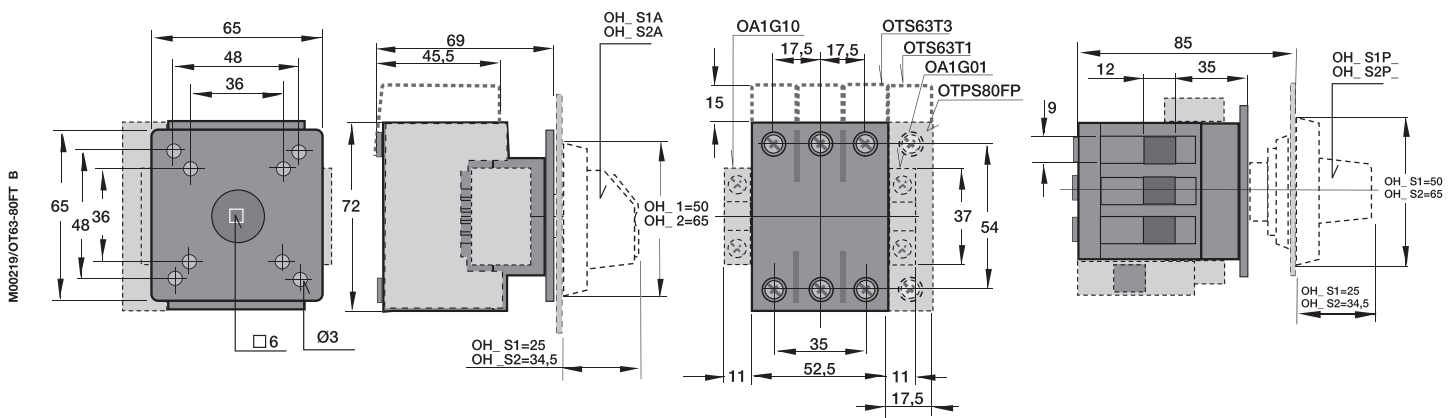

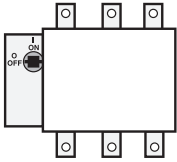

## Approximate dimensions Non-fusible disconnect switches OT30 – OT100



### OT30F3 – OT60F3 – OT100F3 – base & DIN rail mounted switch

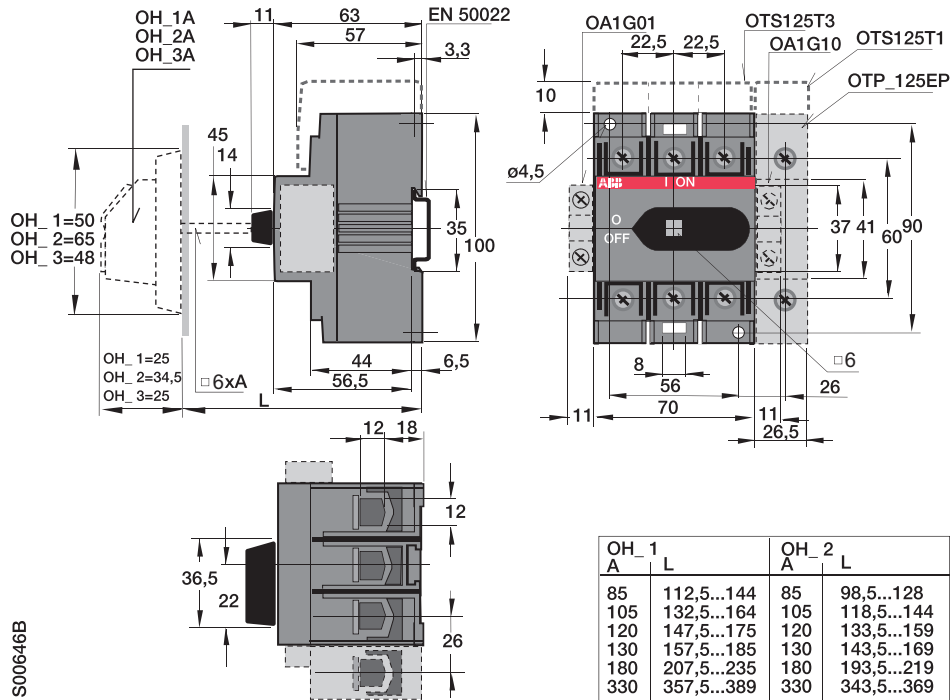

### OT30FT3 – OT60FT3 – OT100FT3 – door mounted switches

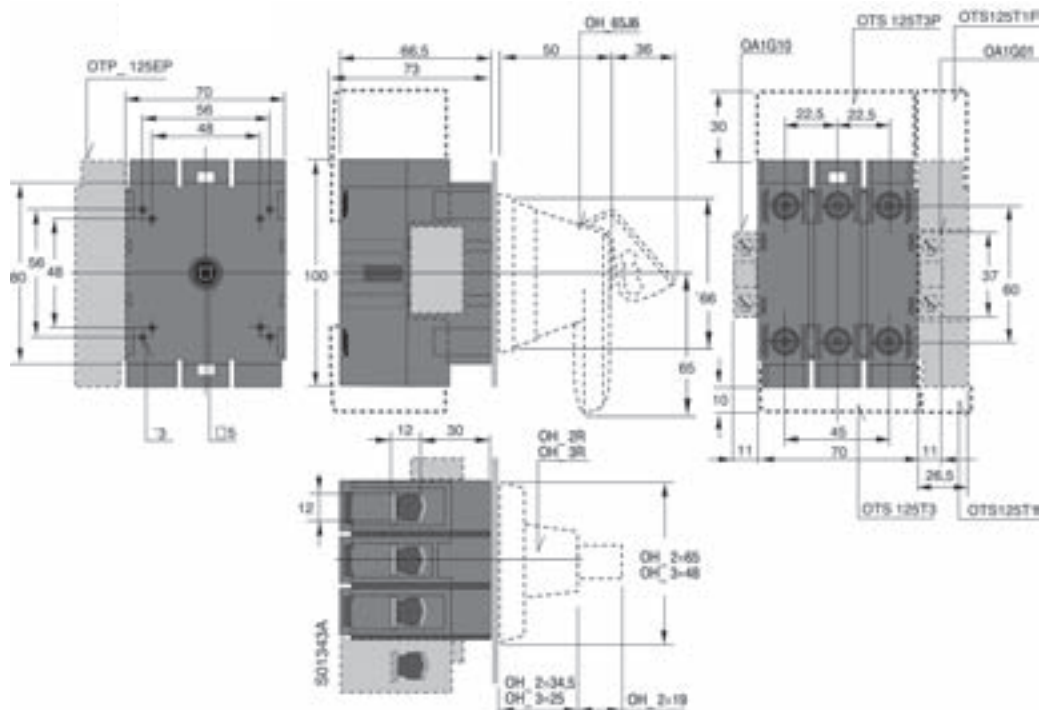





# Approximate dimensions Non-fusible disconnect switches OT160

← 00 → Millimeters

## OT160E3 — base & DIN rail mounted switch

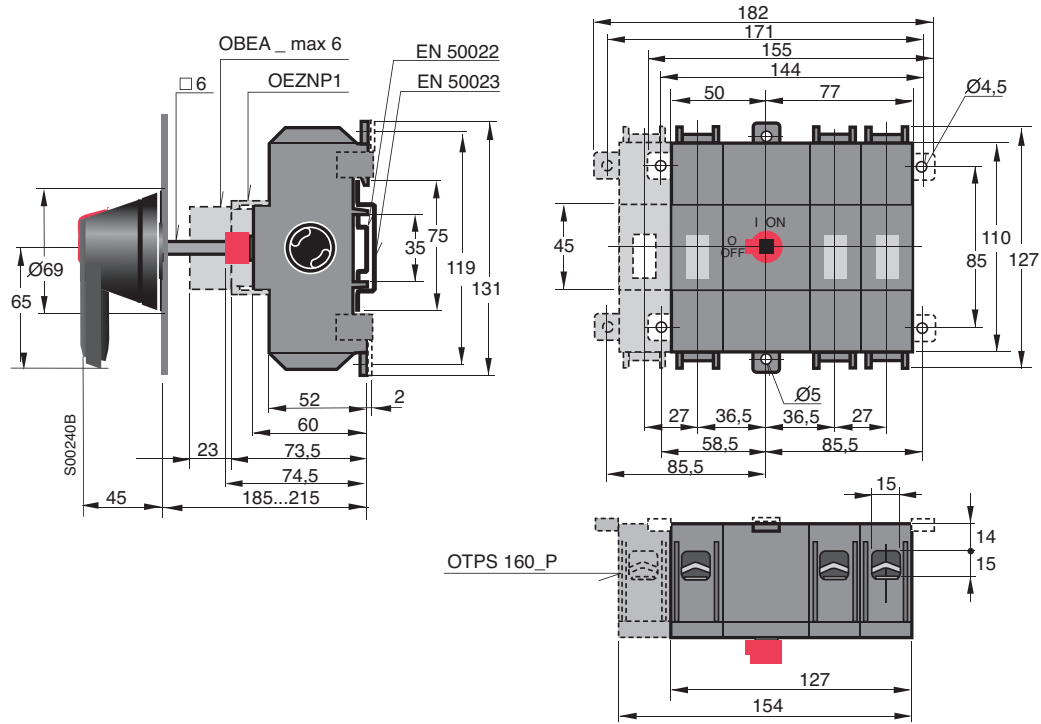

## OT160ET3 — Door mounted switch

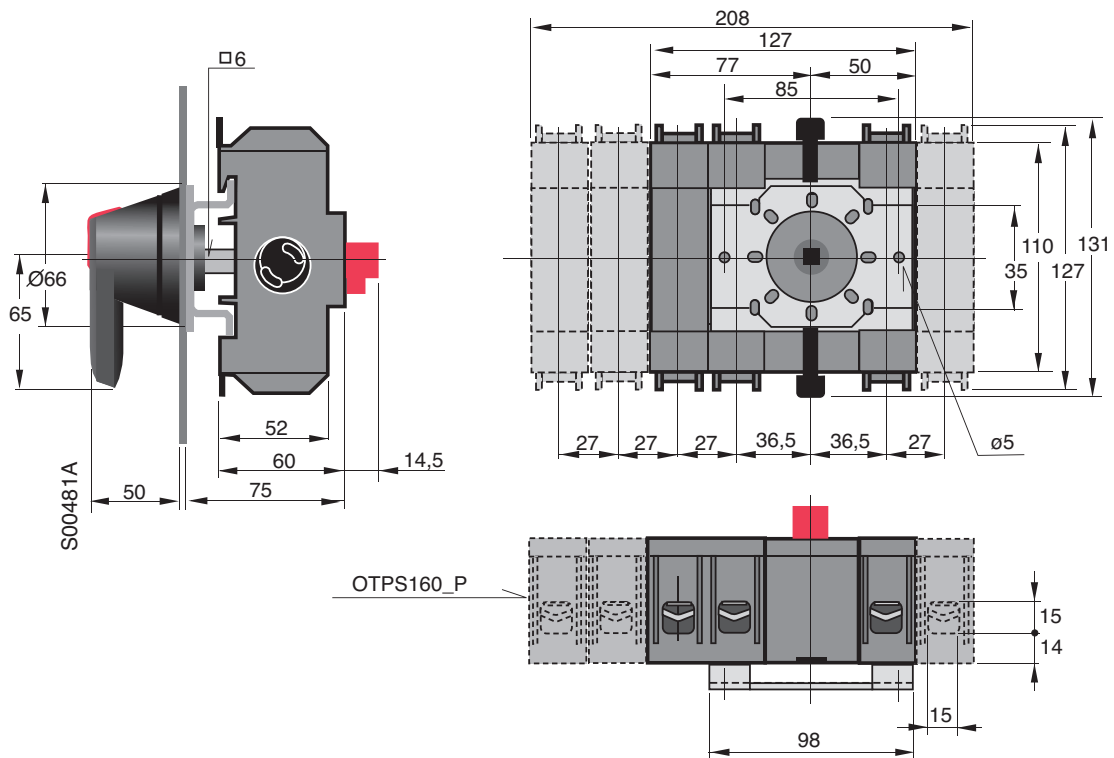

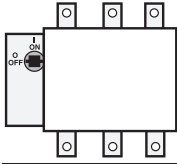

## Approximate dimensions OT16F6 & F8 – OT80F6 & F8 6-pole switches



### OT16, 25, 40F6 & F8 — 6 & 8 Pole switches

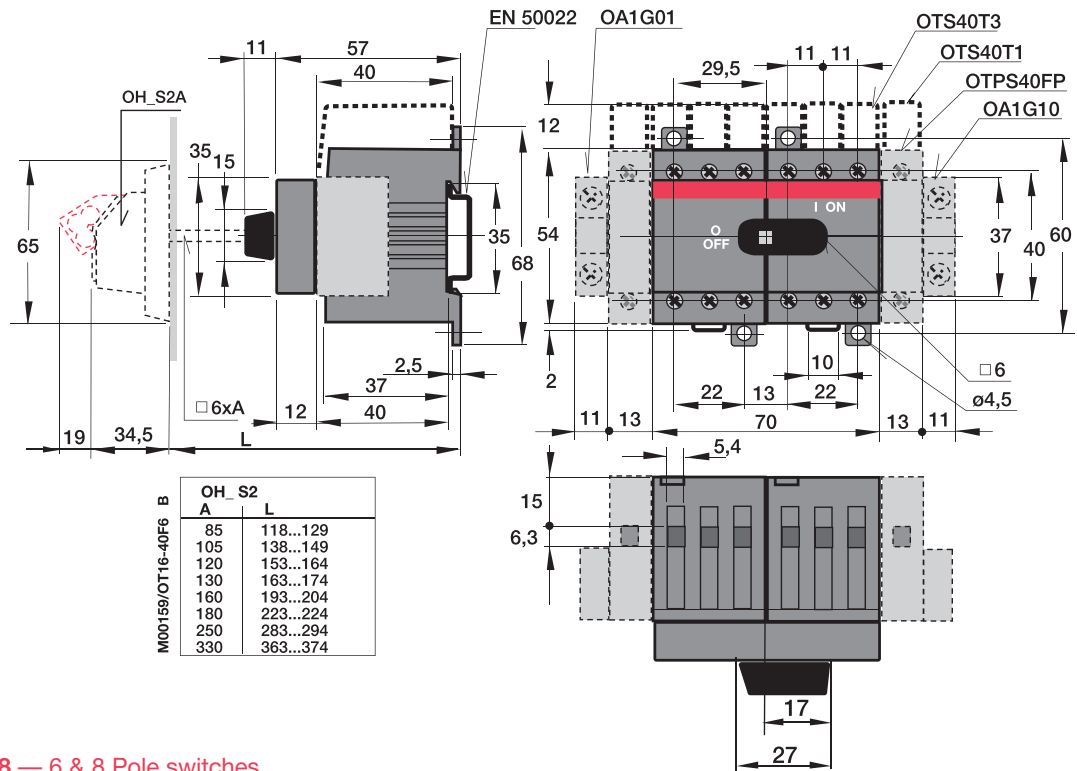

### OT63, 80F6 & F8 — 6 & 8 Pole switches

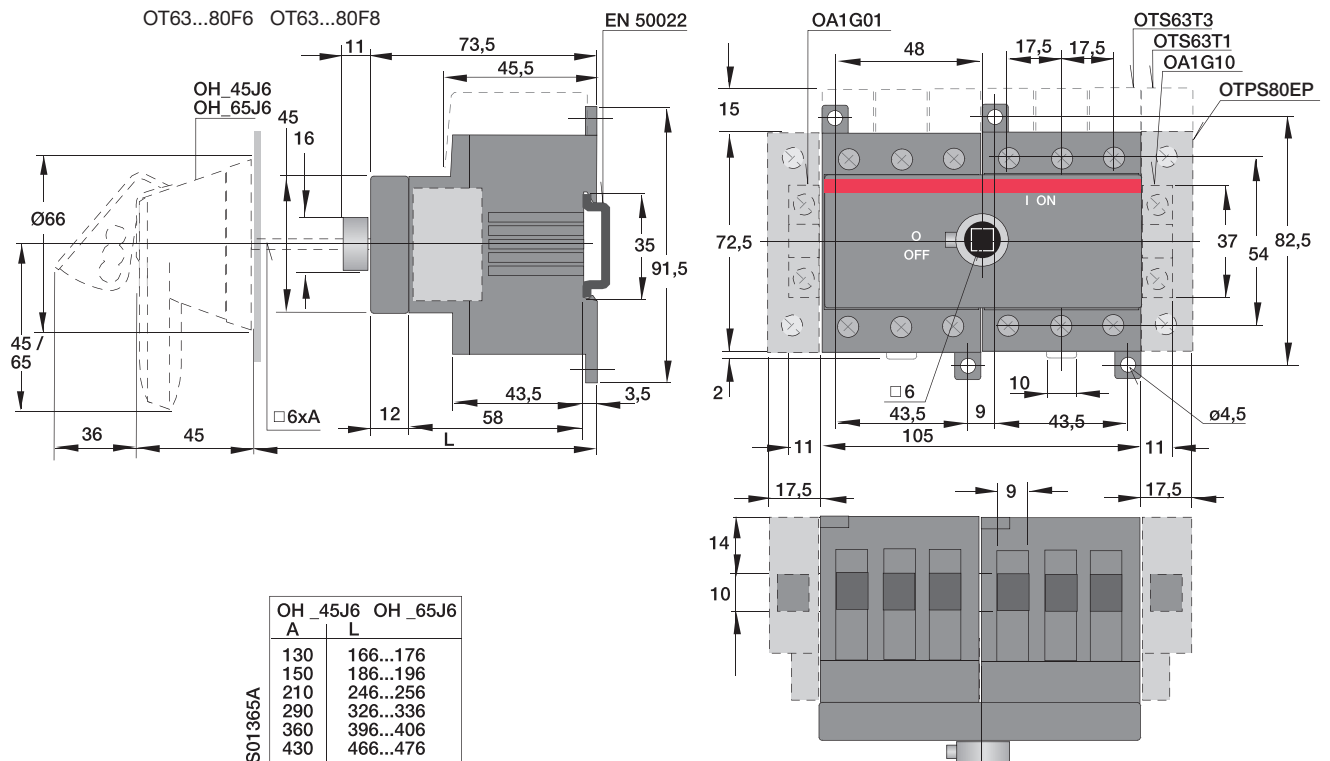



# Approximate dimensions OT16F3C & F4C – OT80F3C & F4C Change-over switches

← 00 → Millimeters

## OT16, 25, 40F3C & F4C – Transfer switches

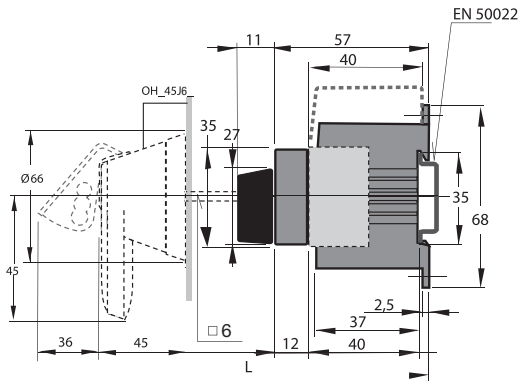

501306A	OH_45J5E311 Shaft OXP6x	L
	150	164...175
	170	184...195
	265	279...290
	400	414...425

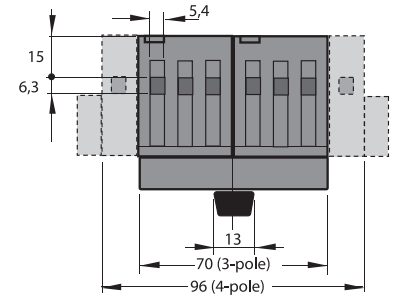
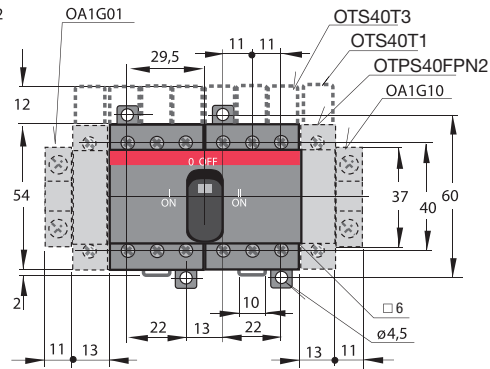

## OT63, 80F3C & F4C – Transfer switches

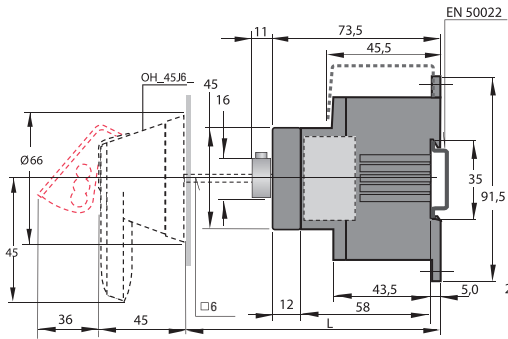

501298A	OH_45J5E311 Shaft OXP6x	L
	150	183...194
	170	203...214
	265	298...309
	400	433...444

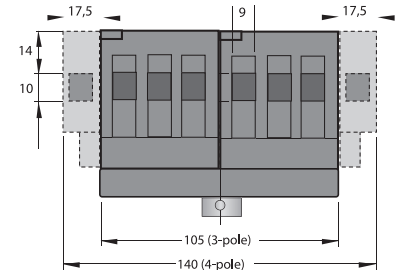
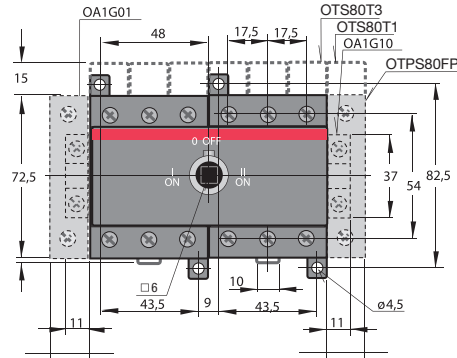

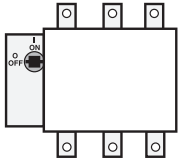

# Approximate dimensions

## OT30, 60, 100F6 & F8 – OT30, 60, 100F3C & F4C



### OT30, 60, 100F6 & F8 — 6 & 8 Pole switches

OT100...125F6 OT100...125F8

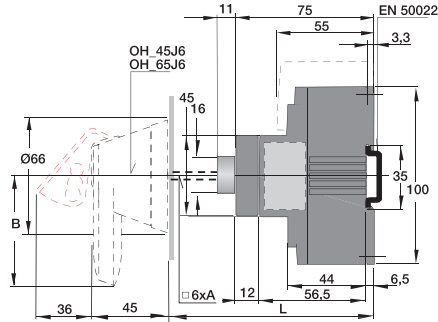

S01386A	OH_45J6	OH_65J6
	A	L
	130	165...175
	150	185...195
	210	245...255
	290	325...335
	360	395...405
	430	465...475

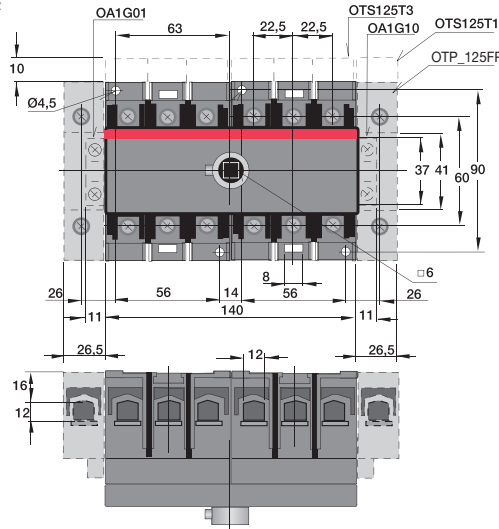

### OT30, 60, 100F3C & F4C

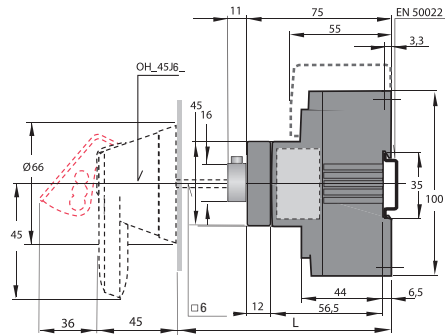

S01399A	OH_45J5E311	L
	Shaft OXP6x	
	150	192...206
	170	212...226
	265	307...321
	400	442...456

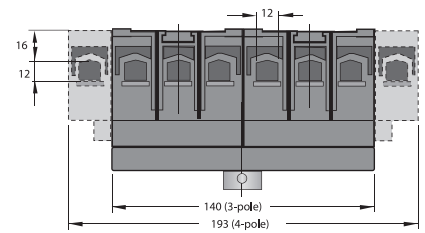
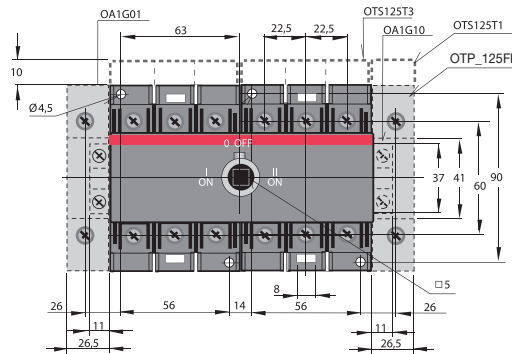



# Approximate dimensions

## Non-fusible disconnect switches

### OT200\_ & OT400\_

← 00 → Millimeters

#### OT200U\_P

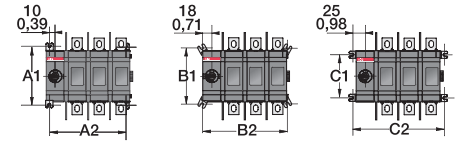
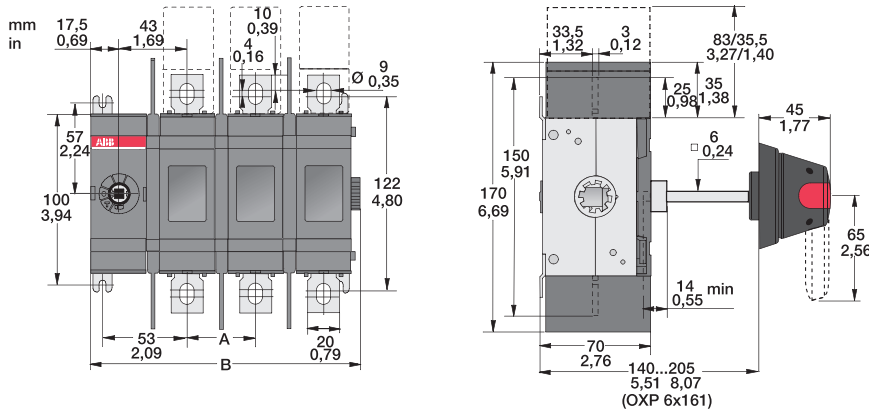

OT200				
	U01	U02	U03	U04
	mm / in	mm / in	mm / in	mm / in
A	-	43 / 1,69	43 / 1,69	43 / 1,69
B	83,5 / 3,24	126,5 / 4,98	169,5 / 6,67	212,5 / 8,37
A1	114 / 4,49	114 / 4,49	114 / 4,49	114 / 4,49
A2	63 / 2,48	106 / 4,17	149 / 5,87	192 / 7,56
B1	109,5 / 4,31	109,5 / 4,31	109,5 / 4,31	109,5 / 4,31
B2	79 / 3,11	122 / 4,80	165 / 6,50	208 / 8,19
C1	84 / 3,31	84 / 3,31	84 / 3,31	84 / 3,31
C2	93 / 3,66	136 / 5,35	179 / 7,05	222 / 8,74

#### OT400U\_P

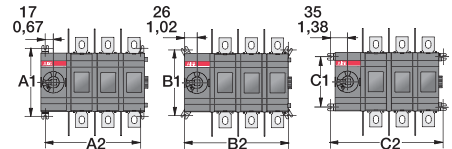
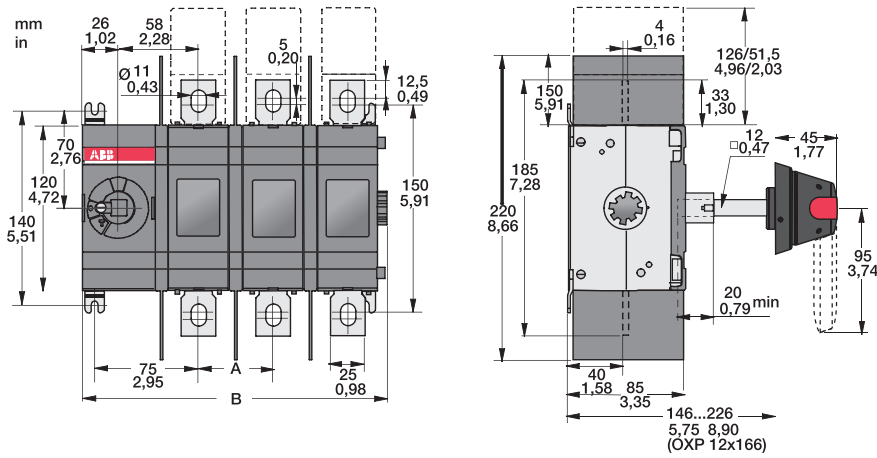

OT400				
	U01	U02	U03	U04
	mm / in	mm / in	mm / in	mm / in
A	-	54 / 2,13	54 / 2,13	54 / 2,13
B	113 / 4,45	167 / 6,58	221 / 8,70	275 / 10,83
A1	140 / 5,51	140 / 5,51	140 / 5,51	140 / 5,51
A2	88 / 3,47	142 / 5,59	196 / 7,72	250 / 9,84
B1	135 / 5,32	135 / 5,32	135 / 5,32	135 / 5,32
B2	106 / 4,17	160 / 4,17	214 / 8,43	268 / 10,55
C1	104 / 4,09	104 / 4,09	104 / 4,09	104 / 4,09
C2	124 / 4,88	178 / 7,01	232 / 9,13	286 / 11,27

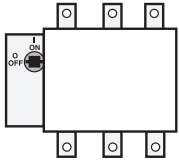

# Approximate dimensions

## Non-fusible disconnect switches

### OT600U\_P ... OT1200U\_P



#### OT600U\_P

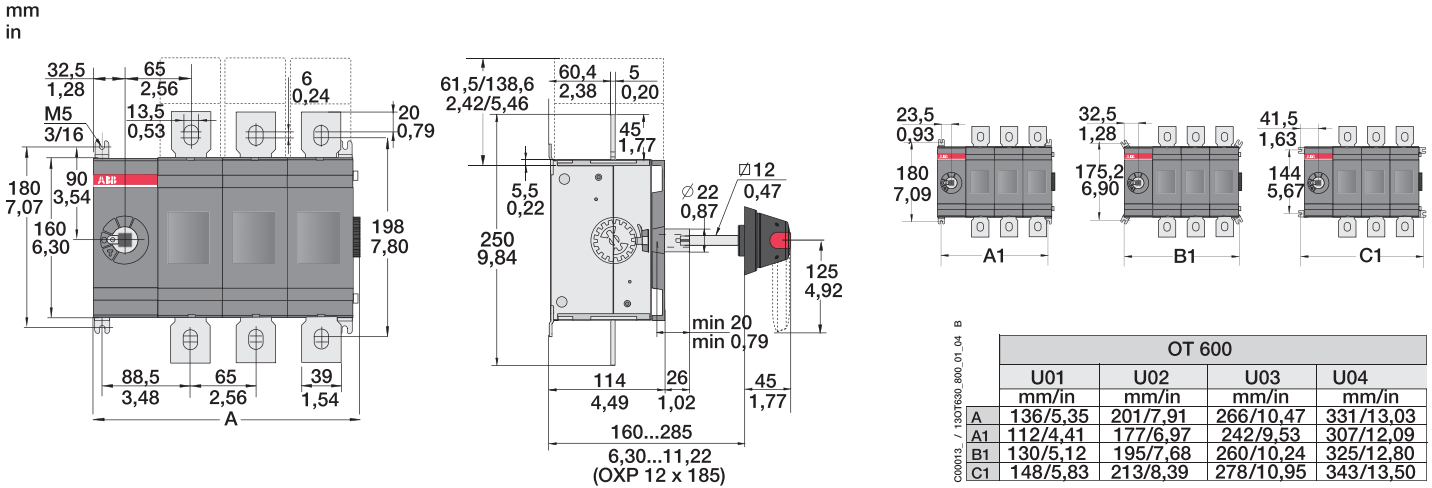

#### OT800U\_P, OT1200U\_P

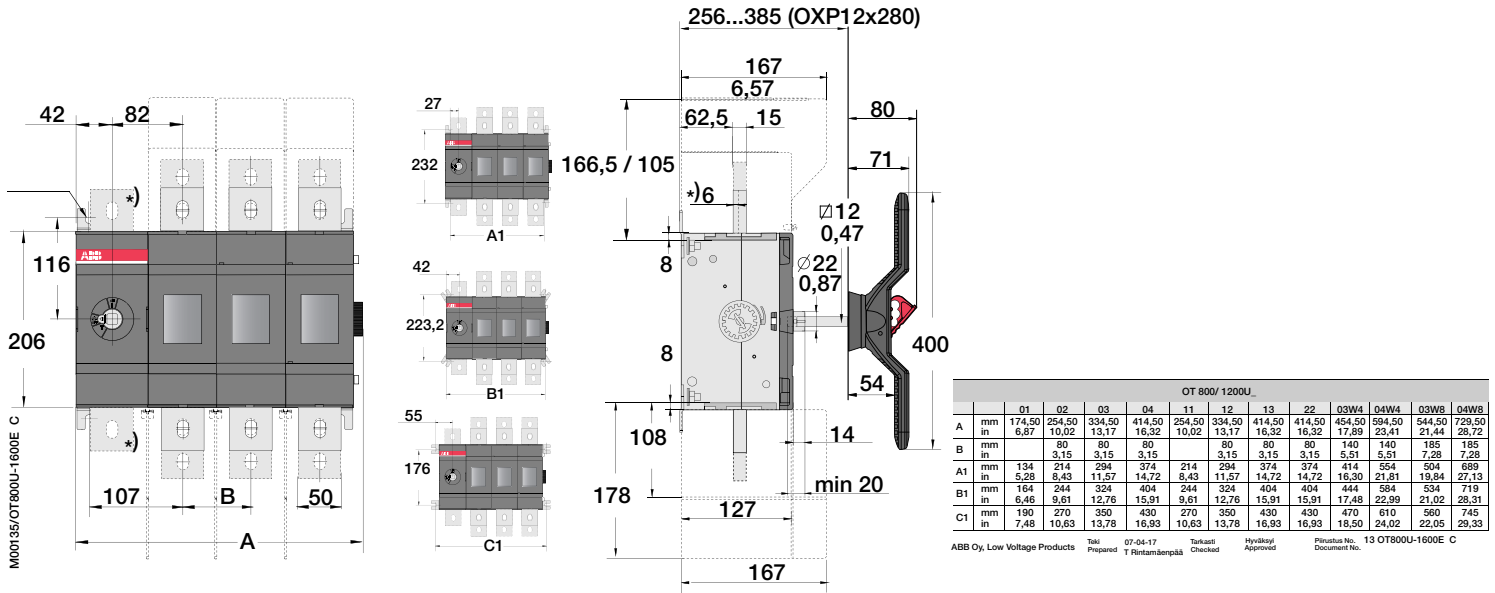



# SwitchLine

## Change-over switches OT200 - 600

### Dimension drawings

← 00 → Millimeters

#### OT200U03/04CP

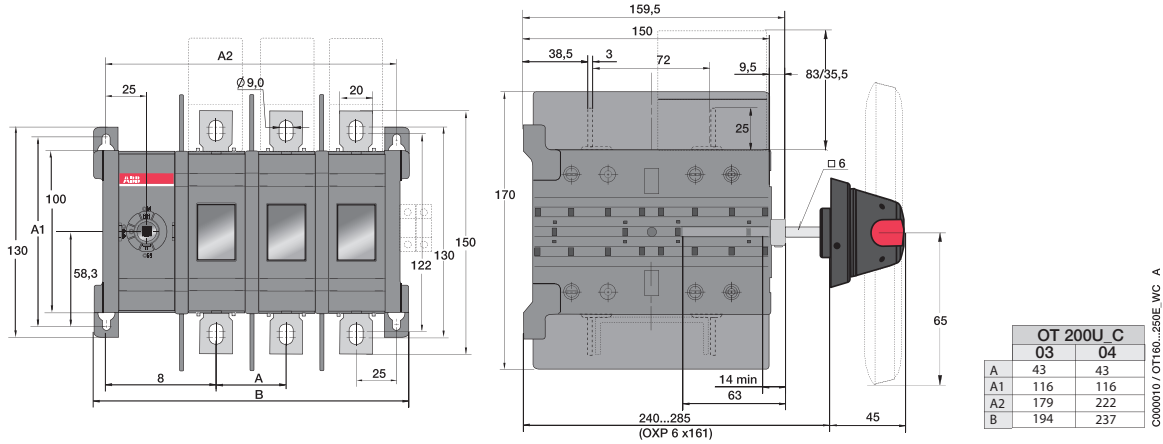

#### OT400U03/04CP

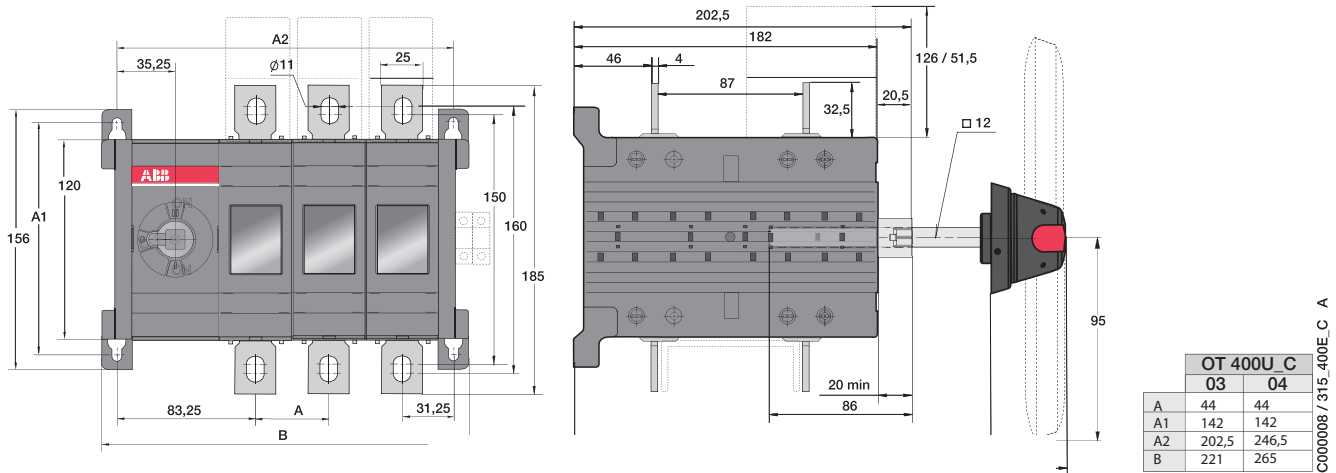

#### OT600U03/04CP

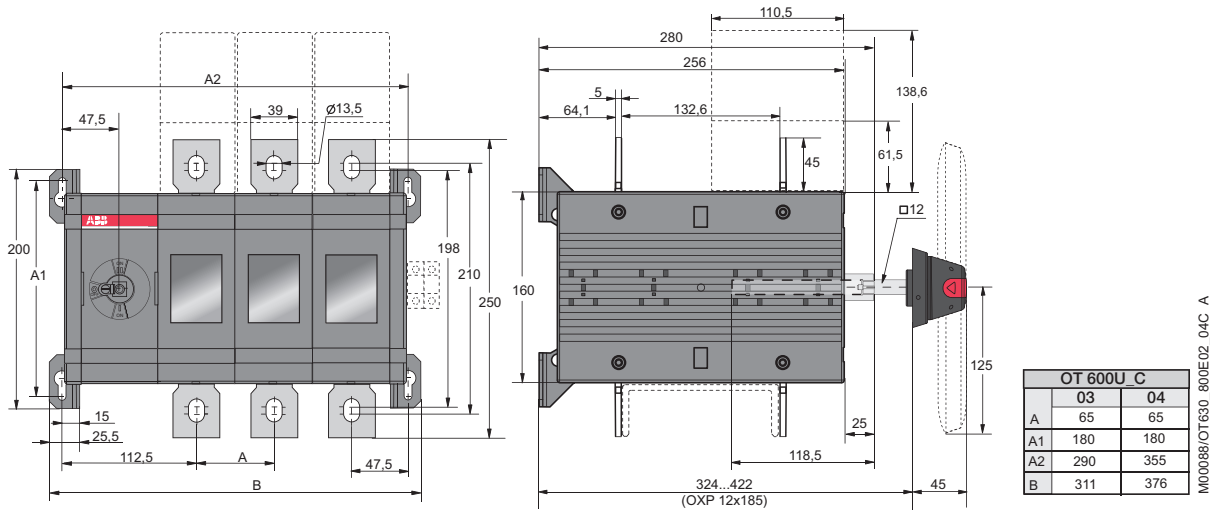

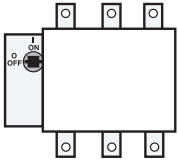

**Approximate dimensions**  
 Non-fusible disconnect switches  
 OETL-NF1600 & OETL-NF2000



**OETL-NF1600P and OETL-NF2000P**

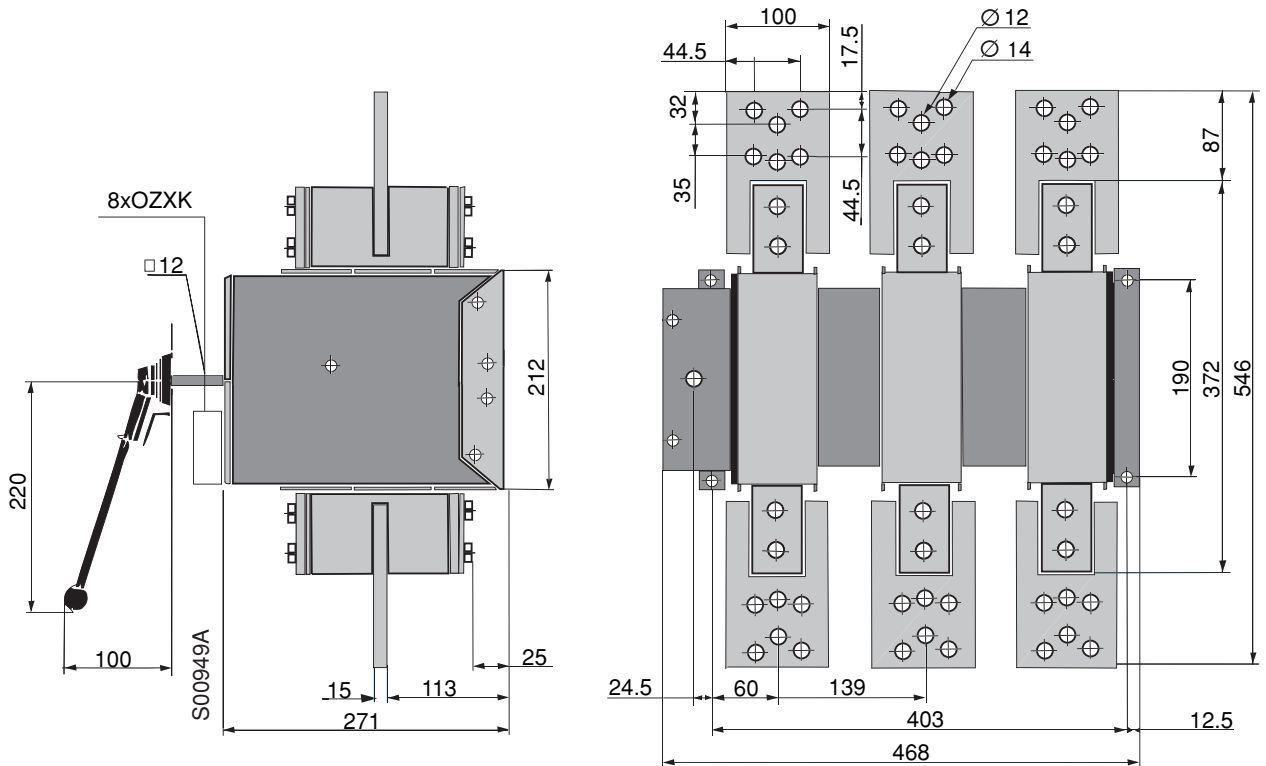





# Approximate dimensions OESC250 — OESC500

← 00 → Millimeters

## OESC250 – OESC500 – 3 pole

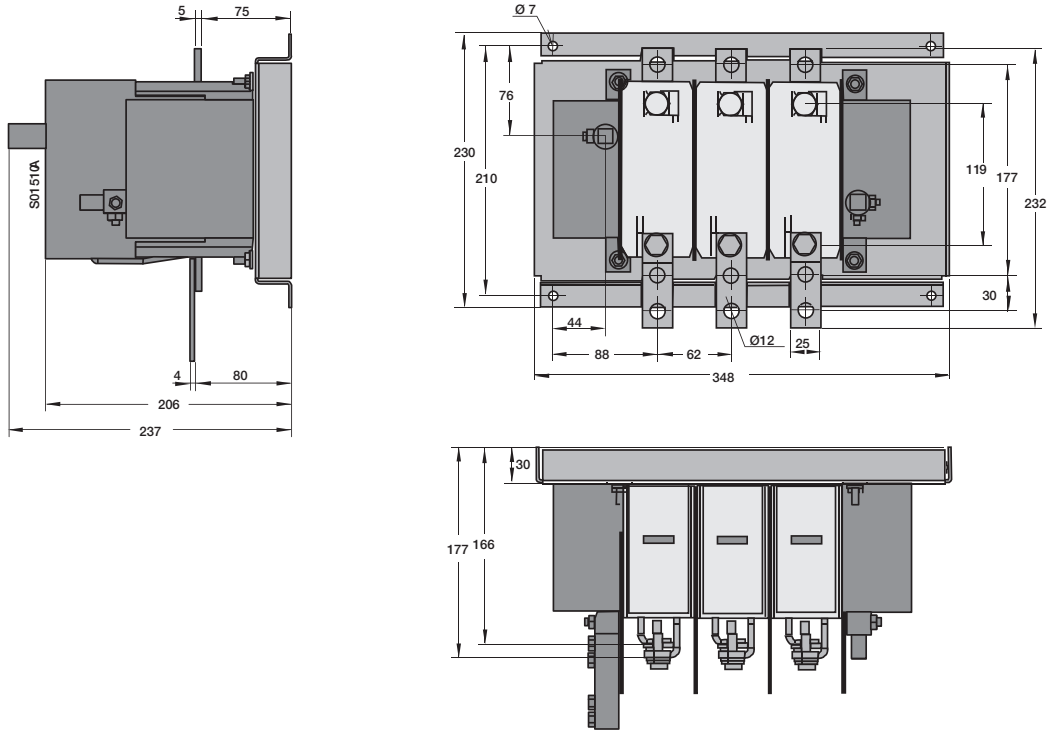

## OESC250 – OESC500 – 4 pole

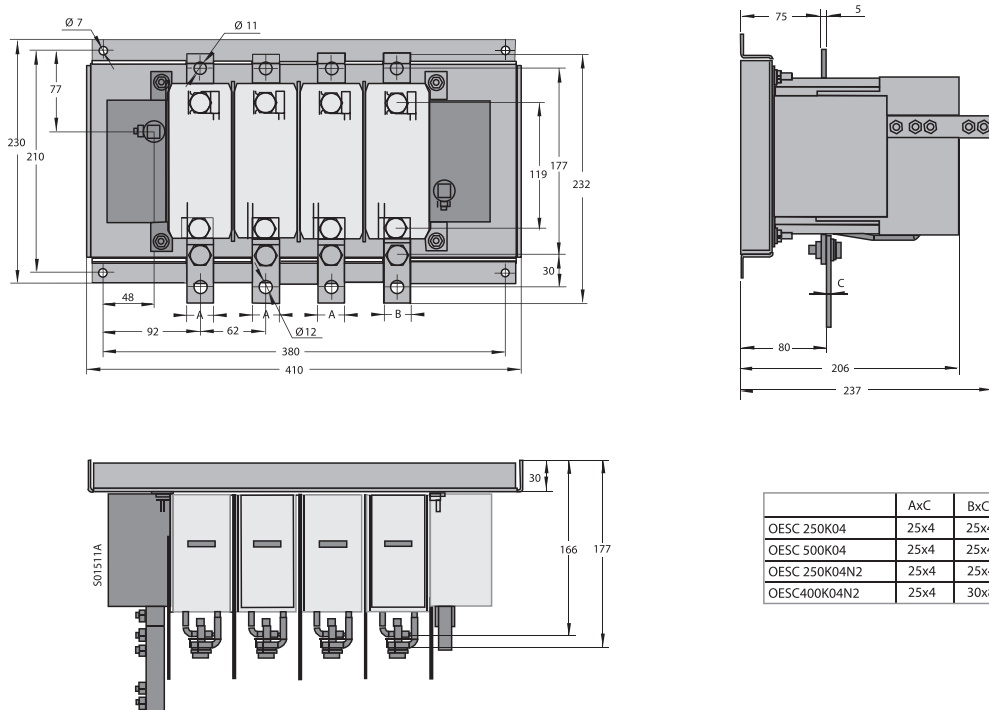

	AxC	BxC
OESC 250K04	25x4	25x4
OESC 500K04	25x4	25x4
OESC 250K04N2	25x4	25x4
OESC400K04N2	25x4	30x8

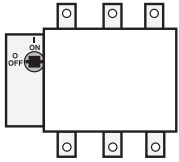

## Approximate dimensions Selector Handles



### Selector handles for base and DIN rail mounted switches

#### OH\_3A

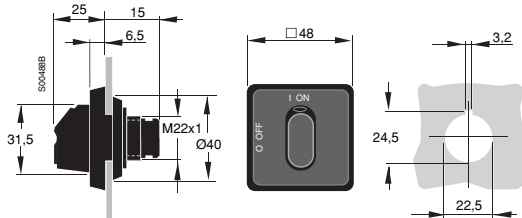

#### OH\_2A\_

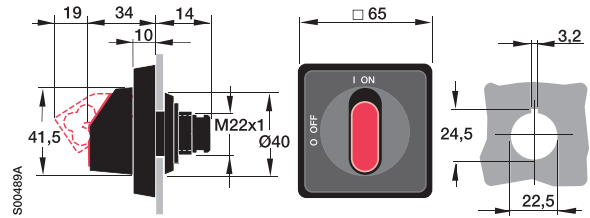

### Selector handles for door mounted switches (Snap-on mounting)

#### OH\_3P\_

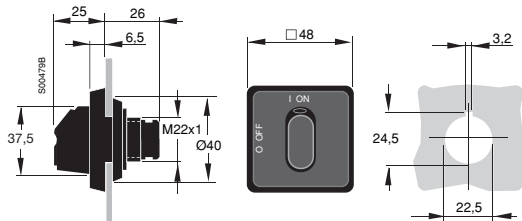

#### OH\_2P\_

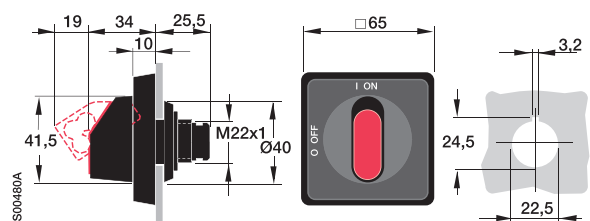

### Selector handles for door mounted switches (Snap-on mounting)

#### OH\_3R\_

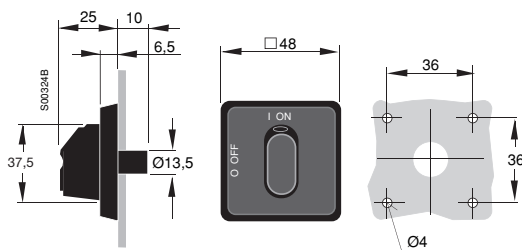

#### OH\_2R\_

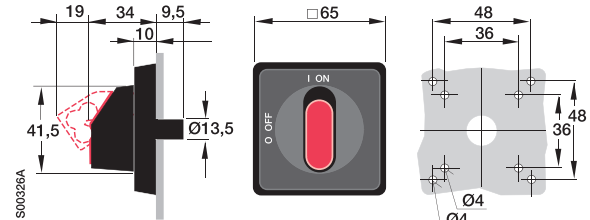



# Approximate dimensions Pistol Handles

← 00 → Millimeters

## Pistol handles

Plastic

Door drilling for  
OH\_-handles:

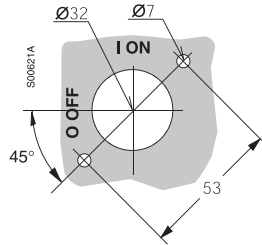
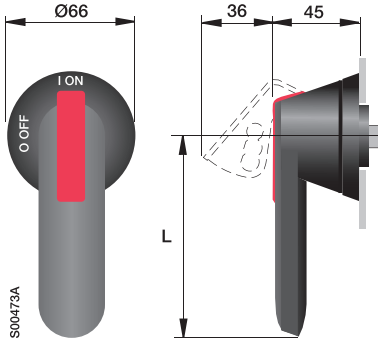

Handle type	Handle length (mm) L	Shaft (mm) B
OH_45J6	45	6
OH_65J6	65	6
OH_80J6	80	6
OH_125J12	125	12
OH_145J12	145	12
OH_175J12	175	12
OH_275J12	275	12

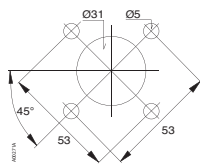
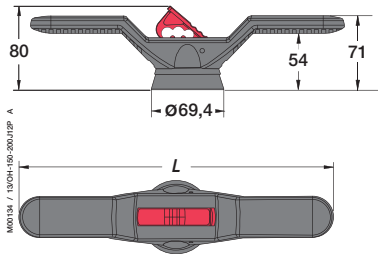

Type	L
OHB150J12	300
OHB200J12	400

## Minimum distance L, between the hinge and the rotating shaft

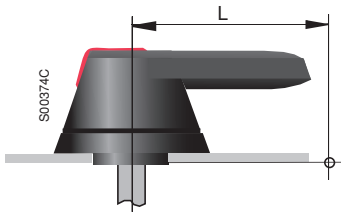

Switch size	Length L (mm)	Handle type
OT16...100	75	OH_2,OH_3
OT16...200	80	OH_65,80J_
OT400...600	150	OH_145J12
OT800...1200	150	OHB150J12P
OETL-NF1600..2000	220	YASDA-7, 8 OH_175J12

## Metallic handles

YASDA-6 (A=320 mm)  
YASDA-7, 8, 21 (A=220 mm)  
YASDA-24 (A=145 mm)

Door drilling for YASDA\_:

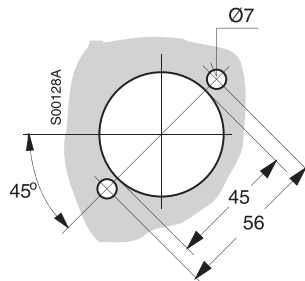
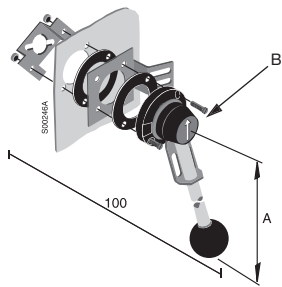

## Stainless Steel

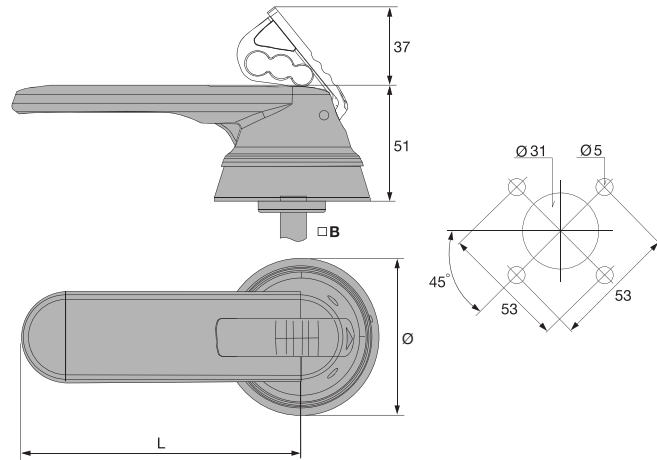

Handle type	OHM45L5	OHM65L6	OHM125L12	OHM175L12	OHM275L12
L	45	65	125	175	275
B	5	6	12	12	12

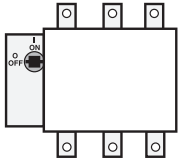

## Approximate dimensions Conversion mechanisms



### 6 or 8 pole switches

OTZW8

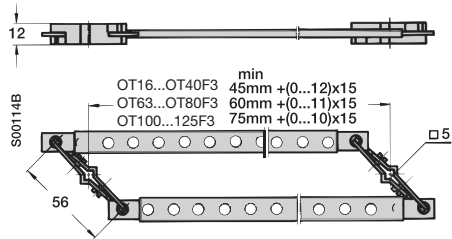

OETL-ZW9

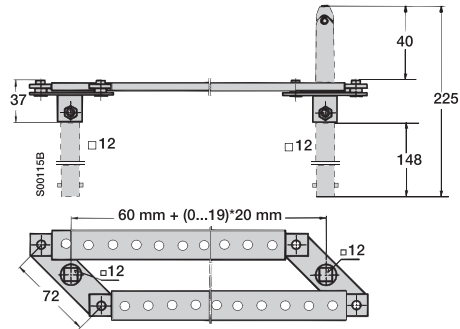

OESA-ZW2

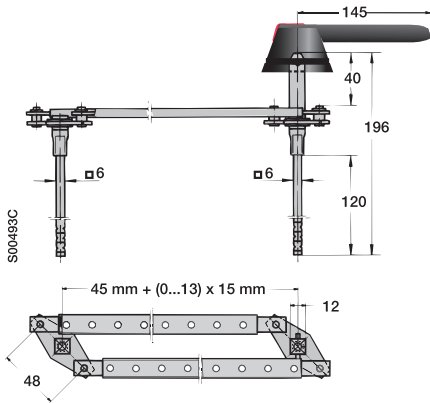

### Mechanical interlock

OETL-ZW15

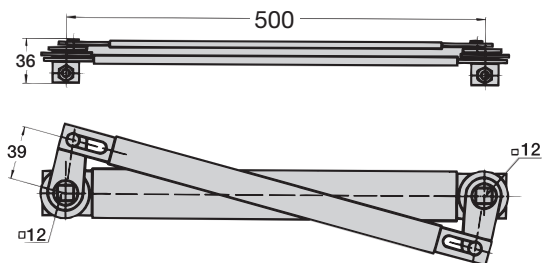

OTZW10  
OTZW24

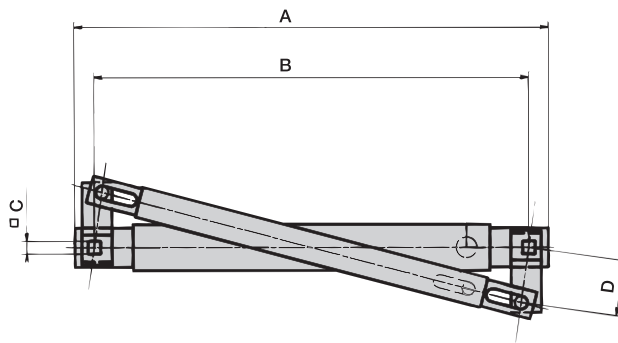

Type	A	B	C	D
OTZW10	206	190	6	30
OTZW24	114	100	5	25

### Change-over switches and by-pass switches

OTZW6, OESA-ZW1

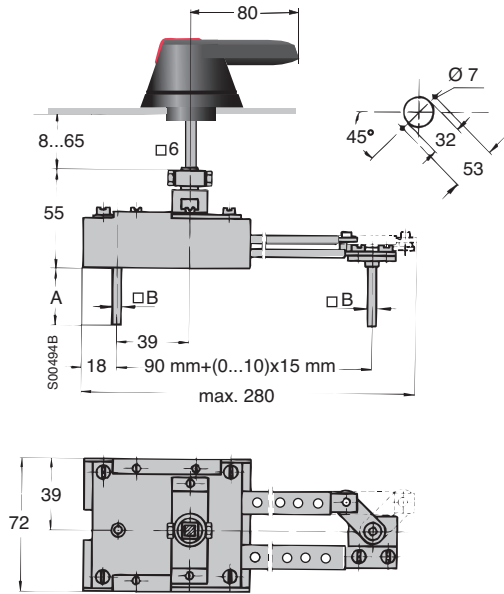

OESAZW1	A	B
OTZW6	116	6
	30	6

OTZW17

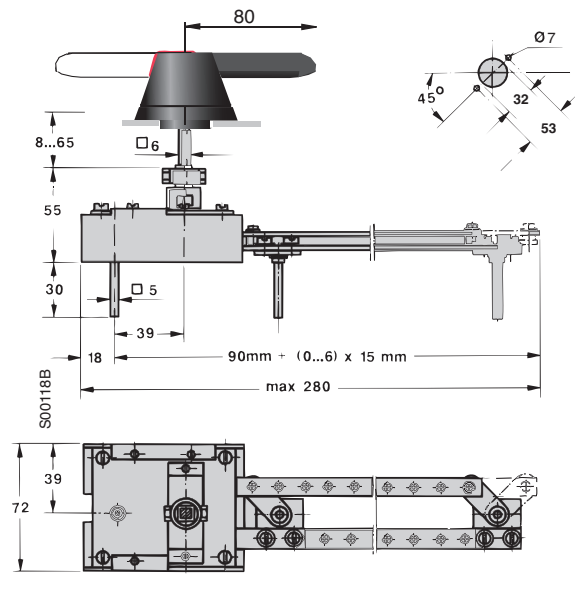

OETL-ZW12, 13

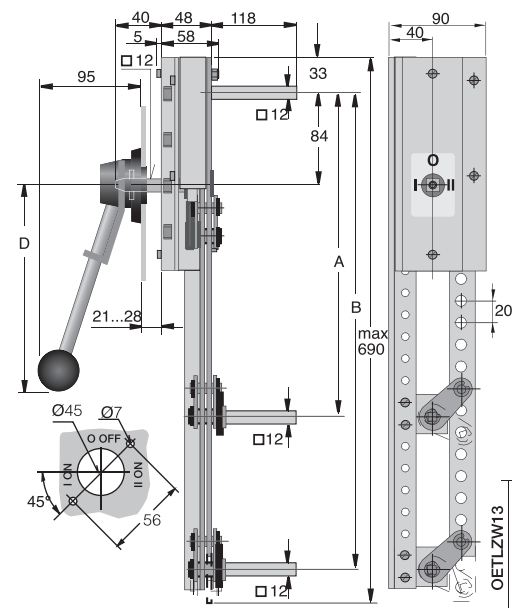

	A	B	D
OETLZW 12	210+(0...18)x20 mm	250+(0...18)x20 mm	220 mm
OETLZW 13	210+(0...18)x20 mm	250+(0...18)x20 mm	320 mm

OTZW25, OTZW26

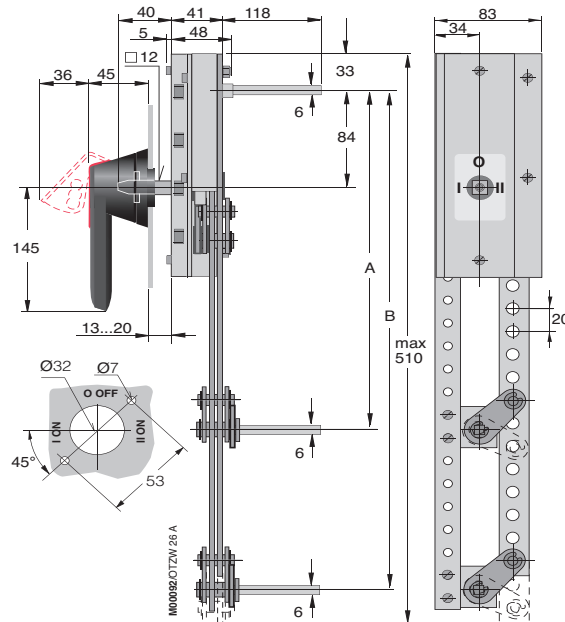

	A	B
OTZW 25	210+(0...18)x20 mm	210+(0...9)x20 mm
OTZW 26	210+(0...9)x20 mm	210+(0...9)x20 mm

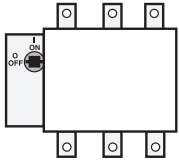

## Approximate dimensions Terminal lugs



**OZXA-200** — for use with 200A switches

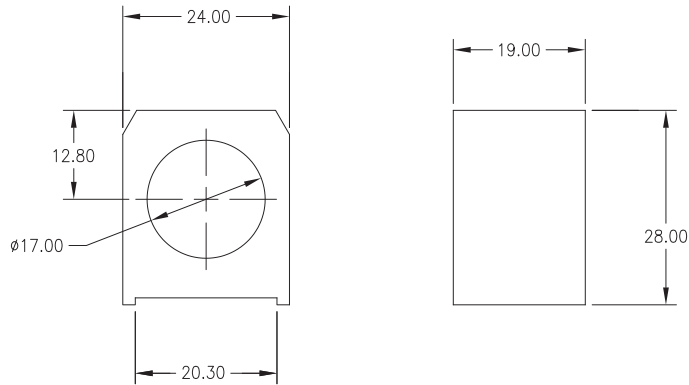

**OZXA-400** — for use with 400A switches

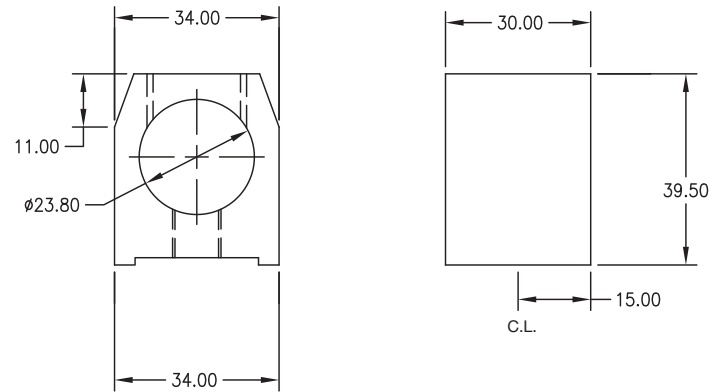

**OZXA-402** — for use with 400A switches

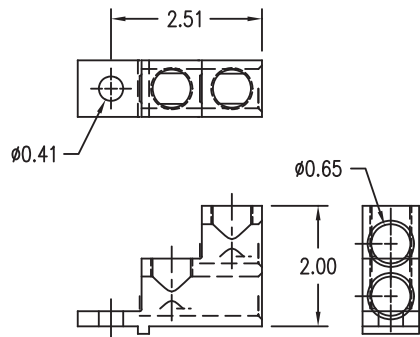

**OZXA-800** — for use with 600A switches

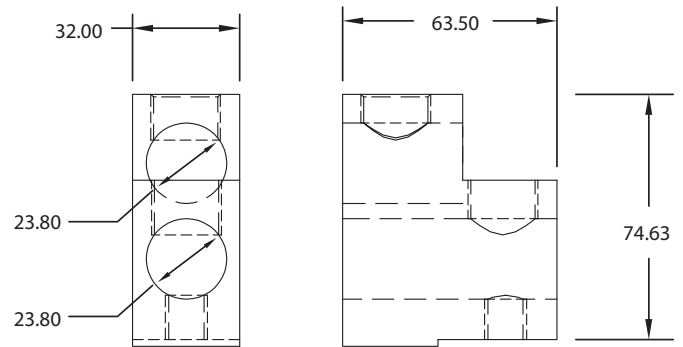

**OZXA-1200** — for use with 800A and 1200A switches

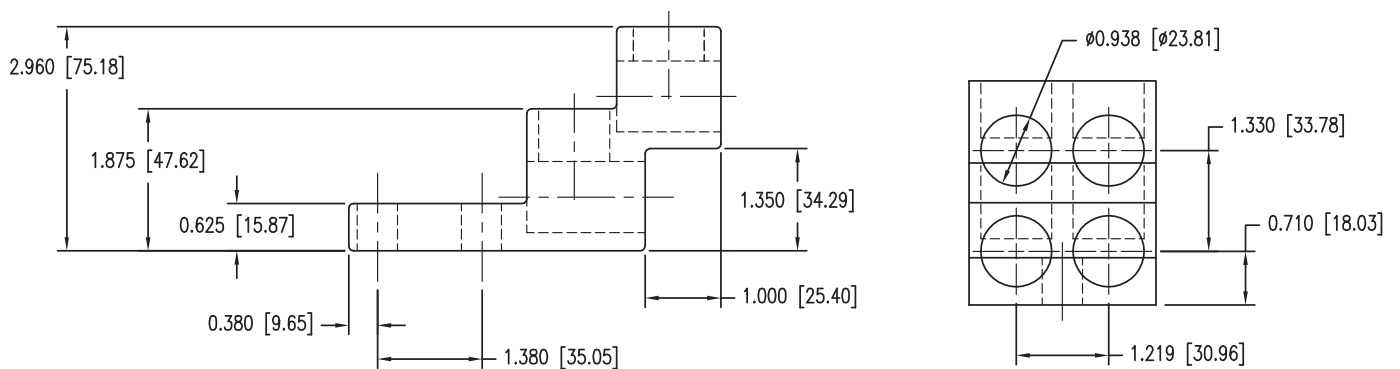



## Approximate dimensions Terminal lugs

← 00 → Millimeters

**DSK8TL and DSK8TM —for use with 1600A-2000A switches**

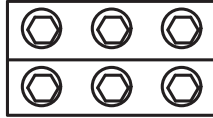
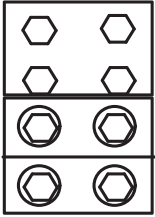

"L"

"M"

( 2500A LUGS SHOWN ON BREAKER )

FIGURE	LUG KIT CAT. NO.	LUG NO.	TEMP.	WIRE RANGE	WIRE TORQUE	MOUNTING TORQUE	WIRE SCREW SIZE
L	DSK8TL	D1922	90° C	1/0 - 750 kcmil (4)	500 lb-in	500 lb-in	1/2
M	DSK8TM	D3185, D3186, D3187	90° C	1/0 - 750 kcmil (6)	500 lb-in	500 lb-in	1/2

NOTE: Lugs are interchangeable and may be ordered as required by the installed wire gauge.







# PowerLine Fusible Disconnect switches



## PowerLine

Fusible disconnect switches

Compact, heavy duty

30A – 1200A, 600V



ABB PowerLine includes seven different amperage sizes from 30A to 1200A. All PowerLine fusible switches are designed to meet customer requirements in terms of high interrupting capacity and long electrical life while occupying little more panel space than the appropriate fuses. The basic construction provides flexibility and high performance in an extremely compact size. ABB PowerLine switches are a perfect choice to withstand the heat and humidity of the tropics, the extreme cold of the arctic and any rugged industrial environment you may have.

### Index

General information .....	2.2 – 2.5
Overview .....	2.6
<b>Fusible disconnect switches for North America and the world: CSA fuse class J,CC,L</b>	
Kits .....	2.7
Individual components:	
30A .....	2.8
60A – 200A.....	2.10
400A – 1200A.....	2.14
Technical information.....	2.25
Technical ratings	
Selecting switches	
Auxiliary contact timing diagrams	
Approximate dimensions	

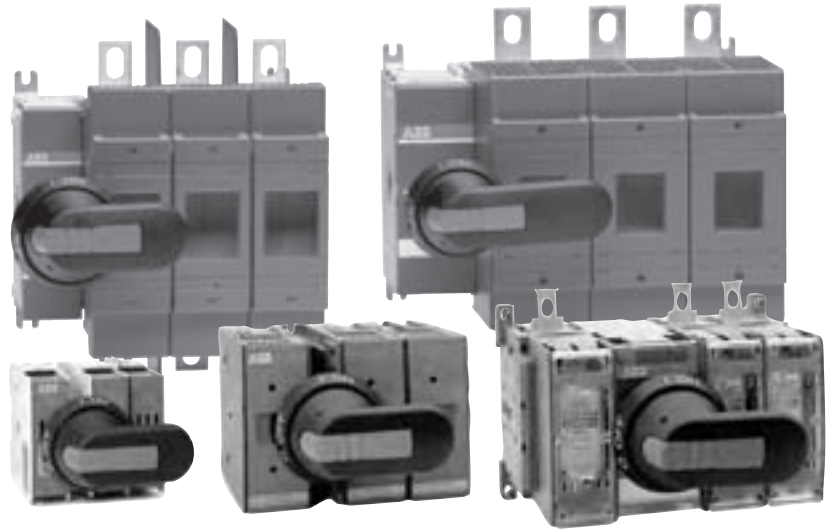

# Complete range of fusible disconnect switches

From 30 to 1200A, 600 V

Features within the range of ABB fusible disconnect switches include single pole to four pole versions.

- The fusible disconnect switches mechanism located in any position together with the direction of the terminals, increasing the ease of installation and adaptability to different types of cubicle designs.
- A wide selection of accessories improve the usability of the switch fuses; 6 and 8- pole, changeover, by-pass and mechanically interlocked switch combinations can be built up by means of conversion kits.

The fusible disconnect switches are available for all types of fuse links, DIN, BS, NFC, UL, CSA.

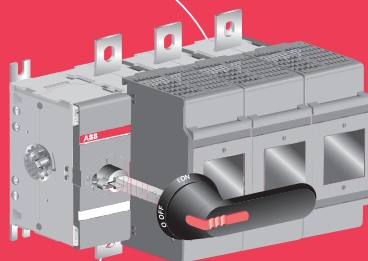
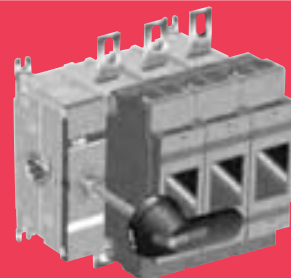
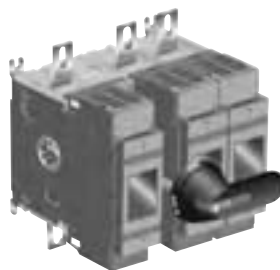
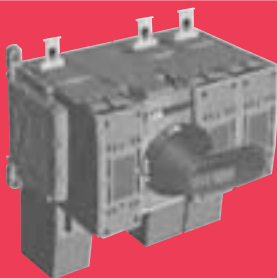
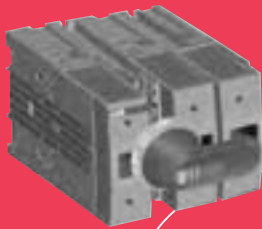

## Designed for safety

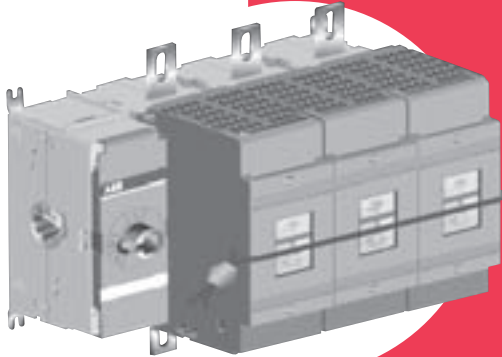
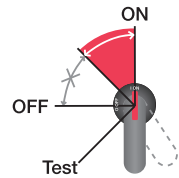

The OS fusible disconnect switch ensures safe operation, protecting both people and equipment.

Designed and based on substantial experience of electrical safety, the fusible disconnect switch eliminates the risk of electrical accidents:

- The fuse covers cannot be opened while the fusible disconnect switch is in the ON-position and can be sealed in the closed position.
- The double insulated external operating handle eliminates the risk of touching live parts outside the box.
- The handle indicates the position of the contacts with complete reliability in all situations.

## Easy, flexible installation

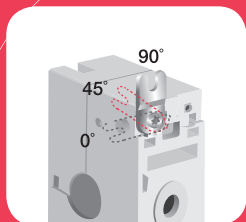

The OS 200...1200 fusible disconnect switch is easy to use and a snap to install according to your choice: the adjustable mounting feet allow both top and side mounting of the fusible disconnect switch.

The OS fusible disconnect switch offers you flexible cabling options. The high terminal positioning with space to the back plate simplifies the mounting of cables. It's also ideal for double cabling, which in turn saves on space.

### OS30

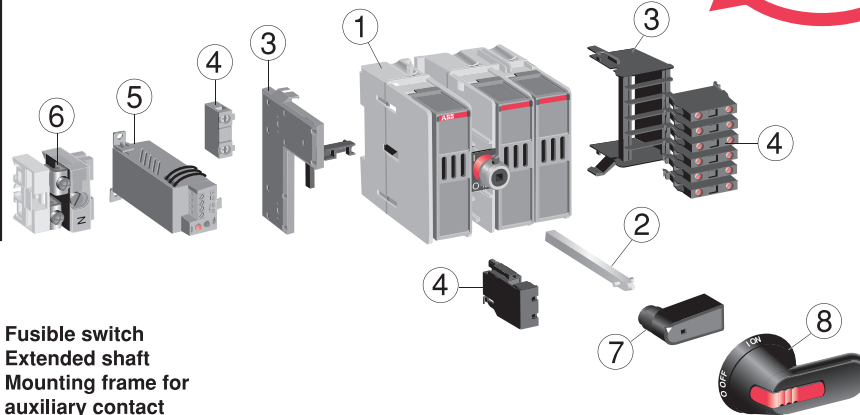

- 1 Fusible switch
- 2 Extended shaft
- 3 Mounting frame for auxiliary contact
- 4 Auxiliary contact
- 5 Fuse monitor
- 6 Neutral link
- 7 Handle knob
- 8 Pistol type handle

### OS60

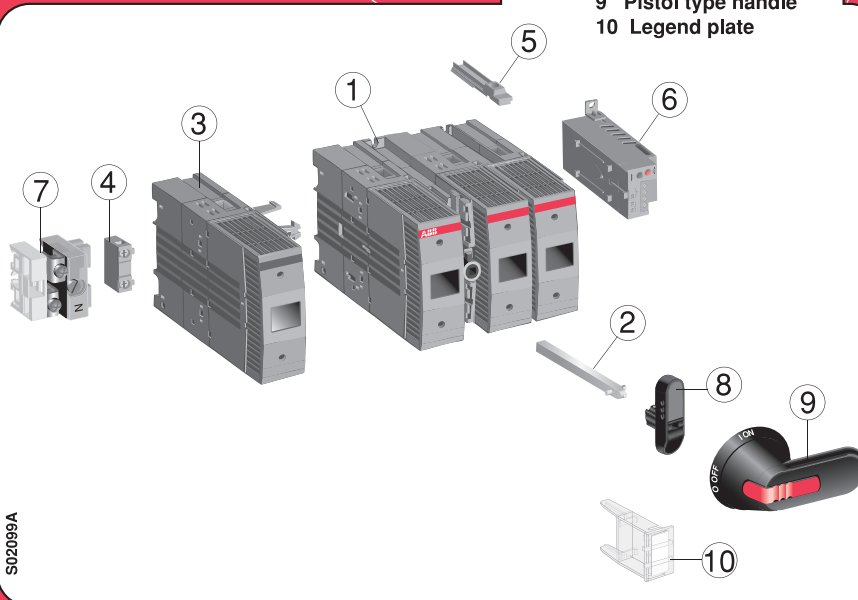

- 1 Fusible switch
- 2 Extended shaft
- 3 Fourth pole
- 4 Auxiliary contact
- 5 Terminal shroud
- 6 Fuse monitor
- 7 Neutral link
- 8 Handle knob
- 9 Pistol type handle
- 10 Legend plate

S02099A

# Fusible disconnect switches OS 100...1200

## Accessories, selection overview



### OS100

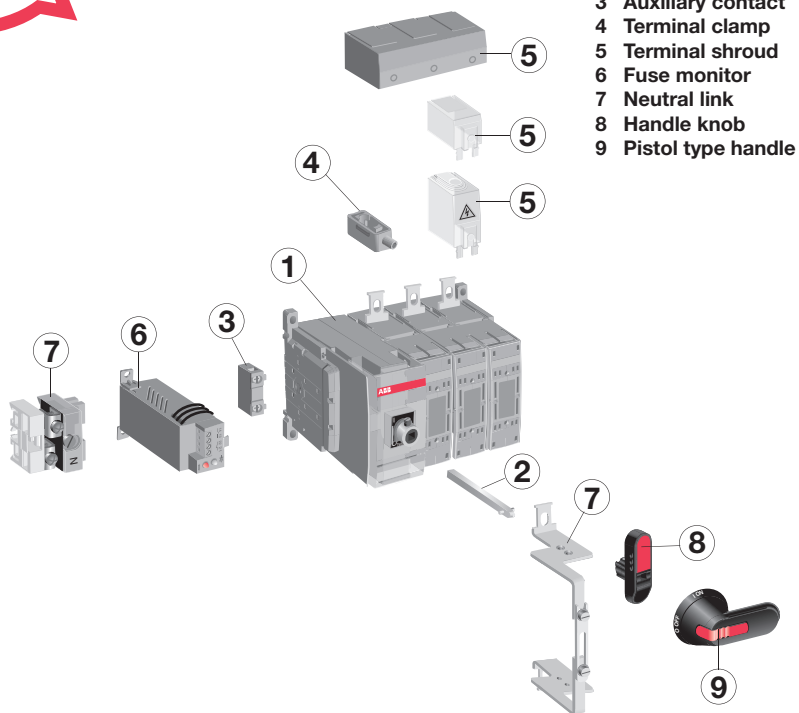

- 1 Fusible switch
- 2 Extended shaft
- 3 Auxiliary contact
- 4 Terminal clamp
- 5 Terminal shroud
- 6 Fuse monitor
- 7 Neutral link
- 8 Handle knob
- 9 Pistol type handle

- 1 Fusible switch
- 2 Extended shaft
- 3 Terminal clamp
- 4 Terminal shroud
- 5 Module for auxiliary contacts
- 6 Auxiliary contact
- 7 Fuse monitor
- 8 Pistol type handle
- 9 Direct mounted handle
- 10 Detachable neutral link

### OS200...OS1200

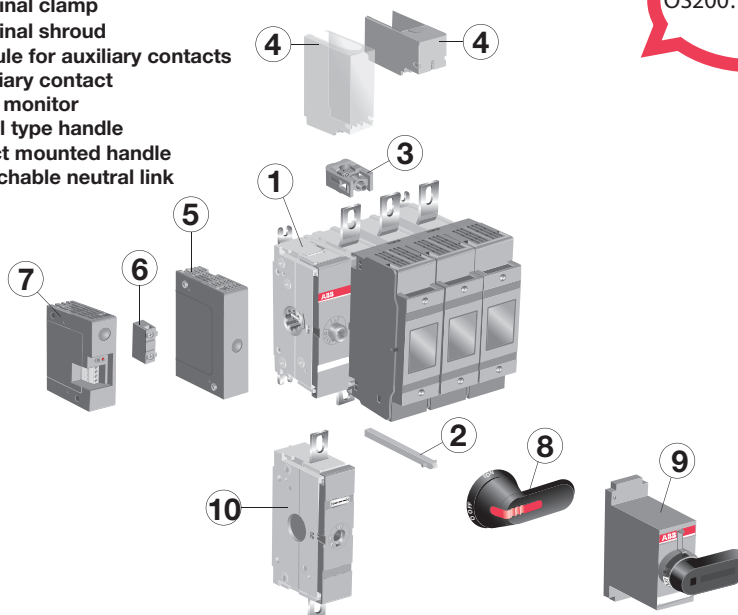

S02100A



# Overview

## Fusible disconnect switches

### OS30FA – OS1200L03

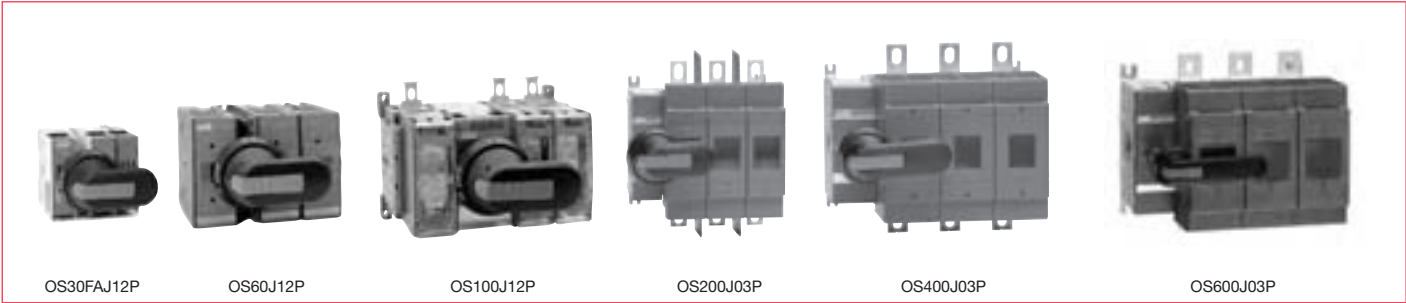

Catalog number	3 pole	OS30FAJ12	OS60J12	OS100J12	OS200J03	OS400J03	OS600J03	OS800L03	OS1200L03
<b>General purpose amp rating</b>	<b>A</b>	<b>30</b>	<b>60</b>	<b>100</b>	<b>200</b>	<b>400</b>	<b>600</b>	<b>800</b>	<b>1200</b>
Catalog reference	Page #	2.9	2.10	2.10	2.14	2.14	2.14	2.14	2.14
<b>Approvals<sup>①</sup></b>									
	2 pole	N/A	N/A	CSA C22.2 No.4	CSA C22.2 No.4	CSA C22.2 No.4	CSA C22.2 No.4	CSA C22.2 No.4	CSA C22.2 No.4
	3 pole	CSA C22.2 No.4	CSA C22.2 No.4	CSA C22.2 No.4	CSA C22.2 No.4	CSA C22.2 No.4	CSA C22.2 No.4	CSA C22.2 No.4	CSA C22.2 No.4
	4 pole	CSA C22.2 No.4	CSA C22.2 No.4	CSA C22.2 No.4	CSA C22.2 No.4	CSA C22.2 No.4	CSA C22.2 No.4	CSA C22.2 No.4	CSA C22.2 No.4
<b>Technical ratings (CSA,UL)</b>									
Max operating voltage	V	600	600	600	600	600	600	600	600
Max horsepower rating									
Three phase									
208V	HP	7.5	15	25	50	100	150	200	—
240V	HP	7.5	15	30	60	125	200	250	—
480V	HP	15	30	60	125	250	400	500	—
600V	HP	20	50	75	150	350	500	500	—
Single phase									
120V	HP	2	—	—	—	—	—	—	—
240V	HP	3	—	—	—	—	—	—	—
CSA fuse class		J/CC	J	J/T	J/T	J/T	J/T	L	L
<b>Technical ratings (IEC)</b>									
Rated insulation and operational voltage, AC20 and DC20 <sup>②</sup>		1000	1000	1000	1000	1000	1000	1000	1000
Rated thermal current, I <sub>th</sub>									
AC 20/DC 20 open	A	32	63	160	200	400	630	800	1250
AC 20/DC 20 enclosed	A	32	63	160	200	400	600	720	1000
AC 21A ≤500V	A	32	63	160	200	400	630	800	1250
≤690V	A	32	63	160	200	400	630	800	1250
Rated operational power AC23									
400/415V	kW	15	30	75	110	220/230	355	400	560
690V	kW	22	55	132	200	400	560	710	1000
Weight	3 pole switch	KG	0.7	1.3	1.5	2.6	5.7	11.5	29
	4 pole	KG	0.9	1.6	1.8	3.2	6.9	14	36
Dimension	3 pole	H mm	97	100	143	200	200	290	287
		W mm	106	145	223	262	285	373	429
		D mm	107	128	131	199	206	234	294
<b>Accessories</b>									
Double break contacts		S	S	S	S	S	S	S	S
Fuse cover		S	S	S	S	S	S	S	S
Terminal lug kit		Integral	Integral	OZXA-24	OZXA-200	OZXA-400	OZXA-800	OZXA-800	OZXA-1200
Terminal shroud		Not required	Not required	•	•	•	•	•	•
Auxiliary contact		•	•	•	•	•	•	•	•
Handle CSA/NEMA type									
Type 1, 3R, 12		•	•	•	•	•	•	•	•
Type 1, 3R, 4, 4X, 12		•	•	•	•	•	•	•	•
Conversion kit									
6 pole		•	•	•	•	•	•	•	•
Transfer		•	•	•	•	•	•	•	•
Bypass		—	—	—	•	•	•	•	•
Mechanical interlock		•	•	•	•	•	•	•	•
Electrical interlock		—	—	—	•	•	•	•	•

**CSA approved, UL listed, IEC rated, CE marked**

S = Standard  
• = Available  
— = Not available

① CSA approved switches are also UL listed.

② 1000V IEC 408

# 30A – 1200A Fusible disconnect switches

## CSA fuse class J, CC, L

### 3 pole<sup>①</sup>



Each kit includes:

- 1 three pole switch
- 1 handle
- 1 shaft

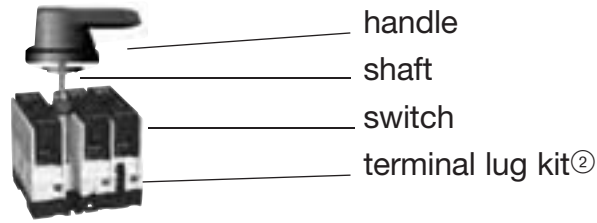

Kit

### Complete Switches (including handle and shaft).

CSA general purpose amp rating	CSA Fuse type 600V	HP					Complete Switches catalog number	List price
		200V	208V	240V	480V	600V		
30	J	5	7.5	7.5	15	20	OS30FAJ12P OS30FACC12P	
30	CC	5	7.5	7.5	15	20		
60	J	15	15	15	30	50	OS60J12P	
100	J	25	25	30	60	75	OS100J12P <sup>②</sup>	
200	J	50	50	60	125	150	OS200J03P <sup>③</sup>	
400	J	100	125	125	250	350	OS400J03P <sup>③</sup>	
600	J	150	150	200	400	500	OS600J03P <sup>③</sup>	
800	L	200	200	250	500	600	OS800L03P	
1200	L	—	—	—	—	—	OS1200L03P	

### Components for complete switches

Kit catalog number	Switch Catalog number	Handle <sup>③</sup>				Shaft			Terminal lugs <sup>②</sup>		
		NEMA type	Marking	De-feat-able	Handle catalog number	Mounting depth <sup>④</sup> (mm)	Length (mm)	Shaft catalog number	Wire size	Wire type	Catalog number
OS30FAJ12P	OS30FAJ12	1, 3R, 12	I/O, OFF/ON	Yes	OHB65J6	135 - 210	150	XP6X150	#18 - #8	Cu	Integral
OS30FACC12P	OS30FACC12	1, 3R, 12	I/O, OFF/ON	Yes	OHB65J6	135 - 210	150	XP6X150	#18 - #8	Cu	Integral
OS60J12P	OS60J12	1, 3R, 12	I/O, OFF/ON	Yes	OHB65J6	141 - 260	150	XP6X161	#14 - #4	Cu	Integral
OS100J12P	OS100J12	1, 3R, 12	I/O, OFF/ON	Yes	OHB65J6	141 - 260	150	XP6X161	#14 - 2/0	Cu/Al	OZXA-24
OS200J03P	OS200J03	1, 3R, 12	I/O, OFF/ON	Yes	OHB80J6	200 - 310	290	XP6X210	#4 - 300kcmil	Cu/Al	OZXA-200
OS400J03P	OS400J03	1, 3R, 12	I/O, OFF/ON	Yes	OHB145J12	200 - 310	280	XP12X280	#2 - 600kcmil	Cu/Al	OZXA-400
OS600J03P	OS600J03	1, 3R, 12	I/O, OFF/ON	Yes	OHB145J12	285 - 355	280	XP12X280	(2) #2 - 600kcmil	Cu/Al	OZXA-800
OS800L03P	OS800L03	1, 3R, 12	I/O, OFF/ON	Yes	OHB145J12	285 - 355	280	XP12X280	(2) #2 - 600kcmil	Cu/Al	OZXA-800
OS1200L03P	OS1200L03	1, 3R, 12	I/O, OFF/ON	Yes	OHB200J12	371 - 500	395	XP12X395	(4) #2 - 600kcmil	Cu/Al	OZXA-1200

If other handles or shafts are desired, please order from the individual component pages 2.8 – 2.14.

① Other pole configurations available. Please see the individual component pages.

② Terminal lug kit for OS100...OS800 are sold separately, see accessories page 2.10 and 2.14.

③ All handles are black and accept three padlocks. For others, please see the individual component pages.

④ Mounting depth is the distance from the outside of the door to the disconnect switch mounting plate. Shaft can be cut to desired length.





## 30A - 200A fusible disconnect switches

### CSA fuse class J, CC

### Handles & shafts

For a complete assembly, please select one of each:

- 1 switch
- 1 handle
- 1 shaft

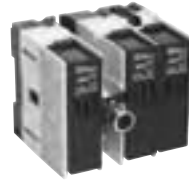

OS30FAJ12

+



OXP6X150

+



OHB65J6



OS30FAJ12P



OHB65J6



OXP6X290

### 30-200 Amp switches, 600V

CSA general purpose amp rating	CSA Fuse type 600V	Maximum horsepower rating					Terminal Lugs		Catalog number	List price
		Three phase					Wire size	Wire type		
		200V	208V	240V	480V	600V				
<b>3 pole</b>										
30	J	5	7.5	7.5	15	20	#18 - #8	Cu	OS30FAJ12	
30	CC	5	7.5	7.5	15	20	#18 - #8	Cu	OS30FACC12	
<b>4 pole</b>										
30	J	5	7.5	7.5	15	20	#18 - #8	Cu	OS30FAJ22F	
30	CC	5	7.5	7.5	15	20	#18 - #8	Cu	OS30FACC22F	
<b>2 pole</b>										
100	J	---	---		---	---	#14 - 2/0	Cu/Al	OS100J02	
200	J	---	---		---	---	#4 - 300kcmil	Cu/Al	OS200J02	
<b>3 pole</b>										
60	J	15	15	15	30	50	#14 - #4	Cu	OS60J12	
100	J	25	25	30	60	75	#14 - 2/0	Cu/Al	OS100J03	
100	J	25	25	30	60	75	#14 - 2/0	Cu/Al	OS100J12	
200	J	50	50	60	125	150	#4 - 300kcmil	Cu/Al	OS200J03	
200	J	50	50	60	125	150	#4 - 300kcmil	Cu/Al	OS200J12	
200	J	50	50	60	125	150	#4 - 300kcmil	Cu/Al	OS200J30	
<b>4 pole</b>										
60	J	15	15	15	30	50	#14 - #4	Cu	OS60J22F	
100	J	25	25	30	60	75	#14 - 2/0	Cu/Al	OS100J22F	
200	J	50	50	60	125	150	#4 - 300kcmil	Cu/Al	OS200J04	

### Pistol handles — for use with shafts ( 6 x 6 mm ) ①

NEMA type	IEC type	Color	Marking	Length inches/mm	Defeat-able	Padlock-able	Catalog number	List price
1,3R,12	IP65	R/Y	O/I & Off/On	65	Yes	Yes	OHY65J6	
1,3R,12	IP65	Grey	O/I & Off/On	65	Yes	Yes	OHG65J6	
1,3R,12,4,4X	IP66	Blk	O/I & Off/On	65	Yes	Yes	OHB65L6	
1,3R,12,4,4X	IP66	R/Y	O/I & Off/On	65	Yes	Yes	OHY65L6	

### Pistol handles — ( 6 x 6mm ) ①

NEMA type	IEC type	Color	Marking	Length inches/mm	Defeat-able	Padlock-able	Catalog number	List price
1,3R,12	IP65	Blk	O/I & OFF/ON	65	Yes	Yes	OHB65J6	
1,3R,12	IP65	R/Y	O/I & OFF/ON	65	Yes	Yes	OHY65J6	
1,3R,12	IP65	R/Y	O/I & OFF/ON	65	Yes	Yes	OHG65J6	
1,3R,12	IP65	Blk	O/I & OFF/ON	80	Yes	Yes	OHB80J6	
1,3R,12	IP65	R/Y	O/I & OFF/ON	80	Yes	Yes	OHY80J6	
1,3R,4,4X,12	IP66	Blk	O/I & OFF/ON	80	Yes	Yes	OHB80L6	
1,3R,4,4X,12	IP66	R/Y	O/I & OFF/ON	80	Yes	Yes	OHY80L6	
1,3R,4,4X,12	IP66	SS	O/I & OFF/ON	65	Yes	Yes	OHM65L6	

### Shafts — for use with pistol handles ( 6 x 6 mm )

Shaft length (mm)	Mounting depth (in mm)	Catalog number	List price
150	130 - 249	OXP6X150	
161	141 - 260	OXP6X161	
210	190 - 309	OXP6X210	
290	270 - 389	OXP6X290	
360	340 - 459	OXP6X360	
430	410 - 529	OXP6X430	

# Accessories

## 30A - 200A fusible disconnect switches

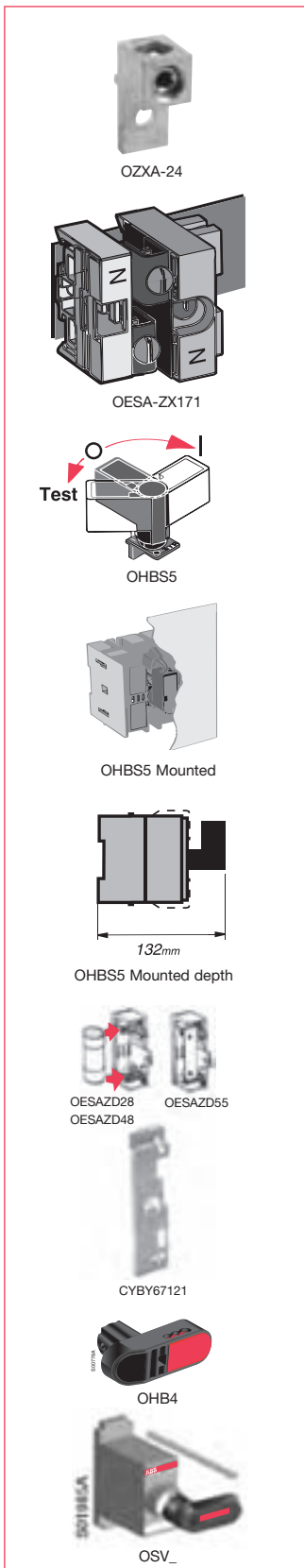

### Shafts alignment ring — for use on :

Description	For use on:	Catalog number	List price
Pistol Handles	OH_45, 65, 80, 125, 145, 175, J, L	OHZX10	

### Terminal lug kit

For use on:	Wire size	Wire type	Terminal lugs per kit	Catalog number	List price
OS100J	#14 – 2/0	Cu/Al	6	OZXA-24	
OS200J	#4 – 300 kcmil	Cu/Al	6	OZXA-200	

### Extension ring for pistol type handles

Description	For use on:	Catalog number	List price
Black	OHB_	OHZX14	

### Terminal pole

Description	For use on:	AC thermal amp rating	AC rated voltage	Catalog number	List price
Detachable neutral mounts on side of switch or DIN rail	OS30FA_	30	600	OESA-ZX171	

### Direct mount handle — mounts directly to switch, no shaft necessary for OS30

NEMA type	Color	Marking	Length mm	Padlockable	Catalog number	List price
1	Blk	O/I/Test	50	Yes	OHBS5 <sup>②</sup>	

### Fuse carriers – (replacement part)

Description	For use on :	Catalog number	List price
CC fuse carrier	OS30FACC_	OESAZD48	
J fuse carrier	OS30FAJ_	OESAZD28	
Solid link carrier	OS30_	OESAZD55	

### Terminal cover – (replacement part)

Description	For use on :	Catalog number	List price
Covers terminal below fuse carrier	OS30FA_	CXBY67121	

### Direct mounted handle

For use on:	Color	Marking	Length mm	Padlockable	Catalog number	List price
OS60-OS100	Black	O/I	50	Yes	OHB4 <sup>③</sup>	
OS200	Black	O/I	50	Yes	OSV200BK <sup>③</sup>	

② Padlockable with three padlocks in the O- position when the door is open.

③ Padlockable with three padlocks in the OFF-position. Includes shaft and mechanism cover.



## Accessories for 30A – 200A fusible disconnect switches

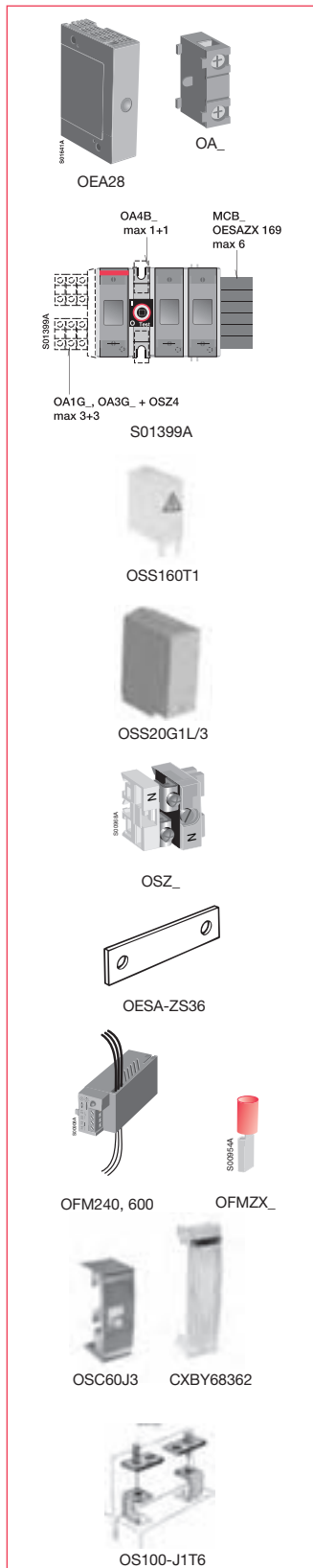

### Auxiliary contacts

Description	For use on:	AC thermal amp rating	AC rated voltage	Catalog number	List price
Form C 1 N.O. & 1 N.C.	OS30 for direct mounting to switch <sup>①</sup>	6	250	OA4B1C	
1 N.O. 1 N.C.	OS30-OS200	10 10	600 600	OA1G10 <sup>②</sup> OA3G01	
Module for aux. contact	OS200			OEA28	
Mounting base (on the left side)	OA1G10 & OA3G01			OSZ4	

1) For OS30: Max. 6 auxiliary contacts mountable onto the left side with the mounting frame OSZ4.

For OS60: Max. 9 auxiliary contacts mountable onto the left side, of which 3 contacts can be used as test indication contacts. NO test indication contact is OA5G10 and NC test indication contact is OA6G10. No frames needed. Max. 2 auxiliary contacts mountable between the poles, which can be used as Test-contacts.

For OS 100...160: Max. 6 aux. contacts per switch side mountable on to the side. The left side: 3 Test-contacts and 3 Test-indication contacts, No frames needed. Max. 3 aux. contacts mountable between the poles, of which two contacts can be used as Test-contacts and one contact is used as Test-indication contact.

For OS200: Max 4 test contacts or 2 test contacts + 2 test indication contacts (Mounting under the mechanism cover)

### Terminal shroud

For use on:	Lug type	Quantity for full protection <sup>②</sup>	Qty per pkg	Catalog number	List price
OS100	OZXA-24	6	1 x 1P	OSS160T1	
OS200	OZXA-200	2	3 x 1P	OSS200G1L/3	
		2	4 x 1P	OSS200G1L/4	

② For both load and line sides

### Terminal poles

Description	For use on:	AC thermal amp rating	AC rated voltage	Catalog number	List price
Detachable neutral mounts on side of switch or DIN rail	OS30	30	600	OESA-ZX171	
	OS60	60	600	OSZ1	
	OS100	100	600	OSZ2	
	OS200	200	600	OXN250	

### Shorting bars

Description	For use on:	AC thermal amp rating	AC rated voltage	Catalog number	List price
Solid links	OS60J	60	600	OESA-ZD54	
	OS100J	100	600	OESA-ZS36	
	OS200J	200	600	OESA-ZK98	

### Fuse monitor, suitable for 3 phase circuits

Description	For use on:	AC rated voltage	Catalog number	List price
The Red LED indicates any BLOWN fuse and the 1 NO and 1 NC aux. contact gives an alarm or a trip signal. The Green LED indicates NORMAL status.	OS30-100	100...240	OFM240	
	OS30-OS200	380...600	OFM600	
	OS200	100...240	OFS240	
	OS200	380...600	OFS600	
Terminal crimp for OS30...200, kit of 6 pieces			OFMZ2	

### Fuse Carriers - (replacement part), kit of 3

Description	For use on:	Catalog number	List price
Removal fuse carrier	OS60	OSC60J3	

### Replacement fuse covers

Description	For use on:	Catalog number	List price
Transparent fuse cover	OS100	CXBY68362	
Fuse Cover	OS200	CXBY68674	
Phase Barrier	OS200	CXBY68794	

### "T" type fuse adapter kit

Description	For use on:	Catalog number	List price
100A, 600V, 3 pole 200A, 600V, 3 pole	OS100	OS100-J1T6	
	OS200	OS200-J2T6	

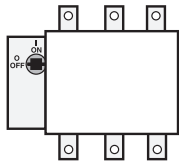

# Accessories for 30A – 200A fusible disconnect switches

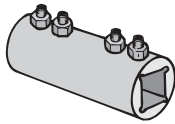

OESA-ZX167  
OETL-ZX95

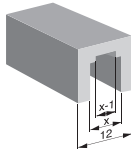

OETL-ZK19  
(X=6MM)

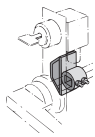

OETL-ZW16

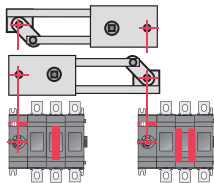

Change-over switches

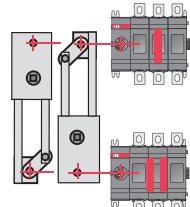

Change-over and  
by-pass switches

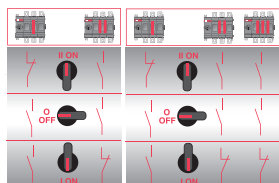

Change-over  
switches

By-pass switches

## Shaft extension coupler

Description	For use on:	Catalog number	List price
Joins two shafts together for applications where extended length is required	12mm shafts	OETL-ZX95	

## Shaft adapter

Description	For use on:	Catalog number	List price
Adapts one end of a 6mm shaft to 12mm. Use with shaft extension coupler	6mm shafts	OETL-ZK19	

## Locking accessories

Description	For use on:	Catalog number	List price
<b>Cam attachment</b> for Kirk Key, interlock. Cam attachment for adapting to the interlock system. The interlock is not included.	OS60, OS100, OS200	OETL-ZW16	

## Conversion mechanisms • Switches are not included

Description	For use on:	Catalog number	List price
6 pole	OS30FA_	OWP6DS1	
8 pole		OWP6DS2	
Transfer 3 pole		OWC6DSH1	
Transfer 4 pole		OWC6DSH2	
Mechanical interlock 3 pole	OS60 - OS200	OWM6DS1	
Mechanical interlock 4 pole		OWM6DS2	
6 and 8 pole	OS60	OESA-ZW2	
Transfer	OS60	OESA-ZW1	
Transfer	OS100 - OS200	OTZW25	
By-pass	OS100 - OS200	OTZW26	

Conversion kit type	To be ordered separately		Included in conversion kit delivery	
	Shaft	Handle	Shaft	Handle
<b>6 and 8-pole switches</b>				
OWP6DS1	X	-	-	-
OWP6DS2	X	-	-	-
OESA-ZW2	-	-	X (2 pcs)	OHB145J12
<b>Change-over switches</b>				
OWC6DSH1	X (length min. 170mm)	-	-	OHB65J5E011
OWC6DSH1	X (length min. 170mm)	-	-	OHB65J5E011
OESA-ZW1	-	-	X (2 pcs)	OHB80H6E011
OTZW25	-	-	X (2 pcs)	OHB95J12E011
<b>Mechanical interlock</b>				
OWM6DS1	X (2 pcs) (length min. 170mm)	X (2 pcs)	-	-
OWM6DS2	X (2 pcs) (length min. 170mm)	X (2 pcs)	-	-

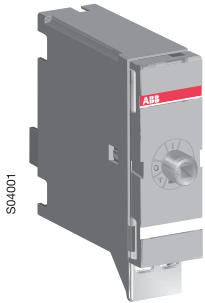
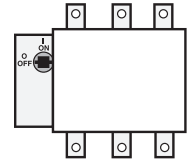

OTZT1\_

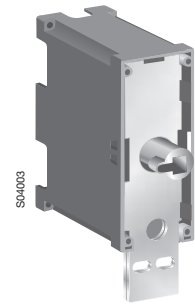

OTZT3\_

### Mechanism interlock kits & Electrical interlocks

OS200...1250 switch fuses can be interlocked in the OFF position using padlocks and by using a mechanical interlock kit mounted on the mechanism.

The diameter of the lock bail can be max dia. 8 mm.

Suitable for switches	Catalog number	List price
Interlocking in the OFF position		
OS200 ... 250_	OSZT1A	
OS315 ... 400_	OSZT2A	
OS600 ... 800_	OSZT3A	
OS1200 ... 1250U_	OSZT4A	
Interlocking in the OFF & ON positions		
OS200 ... 250_	OSZT1L	
OS315 ... 400_	OSZT2L	
OS600 ... 800_	OSZT3L	
OS1200 ... 1250U_	OSZT4L	

### Coils

By installing a coil inside the housing of the interlock kit the switch can be interlocked electrically in the OFF position or both in the OFF and ON positions.

The electrical interlock works using the “closed circuit principle”, meaning that when the control voltage is not connected to the coil, the switches provided with A-type interlocks cannot be turned to the ON position and switches with L-type interlocks cannot be turned to the ON or OFF positions.

Suitable for switches	Catalog number	List price
AC coils		
110 VAC, 50Hz	PDAL2/110AC50Hz	
110 VAC, 60Hz	PDAL2/110AC60Hz	
208 VAC, 60Hz	PDAL2/208AC60Hz	
230 VAC, 50Hz	PDAL2/230AC50Hz	
DC coils		
24 VDC	PDAL2/24DC	
48 VDC	PDAL2/48DC	
60 VDC	PDAL2/60DC	
110 VDC	PDAL2/110DC	
OS600 ... 800_	OSZT3L	
OS1200 ... 1250U_	OSZT4L	

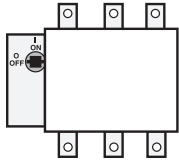

# 400A – 1200A Fusible disconnect switches

## CSA fuse class J, T, L



### 400 – 800 Amp switches, 600V

CSA general purpose amp rating	CSA Fuse type 600V	Maximum horsepower rating Three phase					Catalog number	List price	
		200V	208V	240V	480V	600V			
<b>2 pole</b>	400	J	—	—	—	—	OS400J02		
	600	J	—	—	—	—	OS600J02		
	800	L	—	—	—	—	OS800L02		
	1200	L	—	—	—	—	OS1200L02		
<b>3 pole</b>	400	J	100	125	125	250	350	OS400J03	
	400	J	100	125	125	250	350	OS400J12	
	400	J	100	125	125	250	350	OS400J30	
	600	J	150	150	200	400	500	OS600J03	
	600	J	150	150	200	400	500	OS600J12	
	600	J	150	150	200	400	500	OS600J30	
	800	L	200	200	250	500	600	OS800L03	
	800	L	200	200	250	500	600	OS800L12	
	1200	L	—	—	—	—	—	OS1200L03	
	1200	L	—	—	—	—	—	OS1200L12	
<b>4 pole</b>	400	J	100	125	125	250	350	OS400J04	
	600	J	150	150	200	400	500	OS600J04	
	800	L	200	200	250	500	600	OS800L04	
	1200	L	—	—	—	—	—	OS1200L04	

### Pistol handles — ( □ 12 x 12mm ) ②

NEMA type	IEC type	Color	Length mm	Marking	Defeat-able	Padlock-able	Catalog number	List price
1,3R,12	IP65	Blk	145	O/I & Off/On	Yes	Yes	OHB145J12	
1,3R,12	IP65	R/Y	145	O/I & Off/On	Yes	Yes	OHY145J12	
1,3R,12	IP65	Grey	145	O/I & Off/On	Yes	Yes	OHG145J12	
1,3R,12	IP65	Blk	175	O/I & Off/On	Yes	Yes	OHB175J12	
1,3R,12	IP65	R/Y	175	O/I & Off/On	Yes	Yes	OHY175J12	
1,3R,4,4X,12	IP66	Blk	145	O/I & Off/On	Yes	Yes	OHB145L12	
1,3R,4,4X,12	IP66	R/Y	145	O/I & Off/On	Yes	Yes	OHY145L12	
1,3R,4,4X,12	IP66	Blk	175	O/I & Off/On	Yes	Yes	OHB175L12	
1,3R,4,4X,12	IP66	R/Y	175	O/I & Off/On	Yes	Yes	OHY175L12	
1,3R,4,4X,12	IP65	Metal	220	Off/On	—	Yes	YASDA-8	
1,3R,4,4X,12	IP66	SS	125	O/I & Off/On	Yes	Yes	OHM125L12	
1,3R,4,4X,12	IP66	SS	175	O/I & Off/On	Yes	Yes	OHM175L12	
1,3R,4,4X,12	IP66	SS	275	O/I & Off/On	Yes	Yes	OHM275L12	
Direct Mounted Handle		Metal	220	—	—	—	YASDA-33	

### Direct mounted handles Padlockable with three padlocks in the OFF-position. Includes shaft and mechanism cover

For use on	Color	Description	Marking	Padlockable	Catalog number	List price
OS200	Black	No shaft required	O/I	Yes	OSV200BK	
OS400	Black	No shaft required	O/I	Yes	OSV400BK	
OS600	Black	No shaft required	O/I	Yes	OSV800BK	
OS400-600, OES800	Metal	Mounts on 12mm shaft	-	No	YASDA-33	

### Shaft 12 mm — ( □ 12 x 12mm )

For use on	Shaft length mm	OS400J_	OS600J_ – OS800L_	Catalog number	List price
	250	231 – 340	254 – 325	OXP12X250	
	280	259 – 368	285 – 356	OXP12X280	
	325	305 – 414	330 – 401	OXP12X325	
	395	376 – 485	401 – 472	OXP12X395	
	465	445 – 556	470 – 541	OXP12X465	
	535	516 – 625	536 – 612	OXP12X535	

### Terminal lug kit

For use on:	Wire size	Wire type	Terminal lugs per kit	Catalog number	List price
OS400J_	#2 – 600 kcmil	Cu/Al	6	OZXA-400	
OS400J_	(2)#2 – 300 kcmil	Cu/Al	6	OZXA-402	
OS400J_	(2)#2 – 500 kcmil	Cu/Al	6	OZXA-33	
OS600J_ , OS800L_	(2)#2 – 600 kcmil	Cu/Al	6	OZXA-800	
OS1200L_	(4)#2 – 600 kcmil	Cu/Al	6	OZXA-1200	

① Mounting depth is the distance from the outside of the door to the disconnect switch mounting plate. Shaft can be cut to desired length.

② Plastic pistol grip handle with stainless steel hasp, add suffix EH.

ex.: OHB175J12EH.



## Accessories for 400A – 1200A fusible disconnect switches

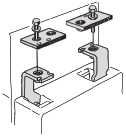
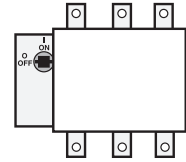

OESAZX1-J\_

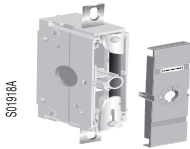

OXN\_

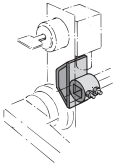

OETL-ZW5

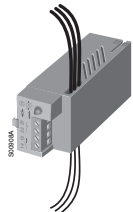

OFM240, 600

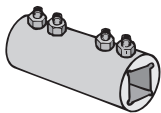

OETL-ZX95

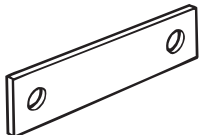

OESA-ZL79

### “T” type fuse adapter kit

For use on :	For use with :	AC thermal amp rating	AC rated voltage	Poles	Catalog number	List price
OS400	600V Class T fuse	400	600	3	OESAZX1-J4T6	
OS600	600V Class T fuse	600	600	3	OESAZX1-J6T6	
OS800	300 & 600V Class T fuse	800	600	3	OESAZX1-L8T6	

### Auxiliary contacts

Description	For use on:	AC thermal amp rating	AC rated voltage	Catalog number	List price
1 N.O.	OS400...1200	10	600	OA1G10	
1 N.C.		10	600	OA3G01	
Module for auxiliary contacts		10	600	OEA28	

For OS1200: Max 8 test contacts and 4 test indication contacts.  
OS400-800: Max 4 test contacts and 4 test indication contacts. The test contacts can be used as standard auxiliary contacts as well. Auxiliary contacts for 3 + N types only with the OEA28 module (Screw mounting to the left side of the switch).

### Detachable neutral links

Description	For use on:	Catalog number	List price
Mounting separately on baseplate protected construction	OS400 OS600-800 OS1200	OXN400 OXN800S OXN1250S	

### Terminal shrouds

For use on:	Lug type	Number of poles	Catalog number	List price
OS400J03	OZXA-400	3P	OESA-ZX70	
OS600J03	OZXA-800	3 x 1P	OSS800G1L/3	
OS400J12	OZXA-400	3P	OETL-ZX94	
OS600J12	OZXA-800	3 x 1P	OSS800GIL/3	
OS800L03	OZXA-800	3 x 1P	OSS800G1L/3	
OS1200L03	OZXA-1200	3 x 1P	OSS1250G1L/3	

### Locking accessories

Description	For use on:	Catalog number	List price
<b>Cam attachment</b> for Kirk Key, interlock. For adapting to the interlock system. The interlock is not included.	OS400...1200	OETL-ZW5	

### Fuse monitor, suitable for 3 phase circuits – OS200-800

Description	AC rated voltage	Catalog number	List price
The Red LED indicates any BLOWN fuse and the 1 NO and 1 NC aux. contact gives an alarm or a trip signal. The Green LED indicates NORMAL status.	100...240	OFM240	
	380...600	OFM600	
Terminal crimp for OS, kit of 6 pieces		OFMZXR2	
Terminal crimp for OS1200, kit of 6 pieces		OFMZXR4	

### Shaft extension coupler

Description	For use on:	Catalog number	List price
Joins two shafts together for applications where extended length is required	12mm shafts	OETL-ZX95	

### Shorting bars

Description	For use on:	AC thermal amp rating	AC rated voltage	Catalog number	List price
Solid links	OS400, OS600, OS800	800	600	OESA-ZL79	

★ - Coil voltage  
Ⓢ - Not CSA Approved

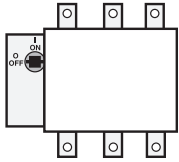

# Accessories for 400A – 1200A fusible disconnect switches



## Conversion mechanisms

- Switches are not included

Description	For use on:	Catalog number	List price
6 or 8 pole Transfer Bypass	OS400	OETL-ZW9 OETL-ZW12 OETL-ZW13	
Mechanical interlock	OS400 ... OS1200	OETL-ZW15	

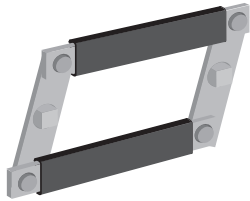

OETL-ZW9

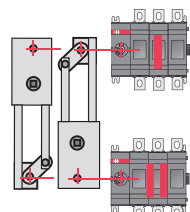
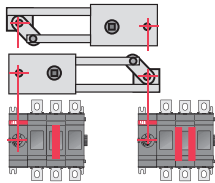

Change-over switches

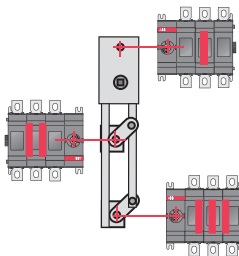

Change-over and by-pass switches

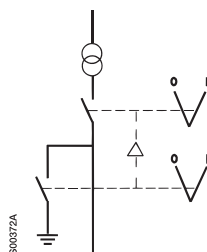

Mechanical Interlock

## The shafts and handles for conversion kits

Conversion kit type	To be ordered separately		Included in conversion kit delivery		The standard handle or shaft of one of the combined switches can be used	
	Shaft	Handle	Shaft	Handle	Shaft	Handle
<b>6 and 8-pole switches</b>						
OETLZW9	-	-	-	-	X	X
<b>Change-over switches</b>						
OETLZW12	-	-	X (2 pcs)	YASDA21	-	-
<b>By-pass switches</b>						
OETLZW13	-	-	X (3 pcs)	YASDA6	-	-
<b>Mechanical interlock</b>						
OETLZW15	-	-	-	-	x	x

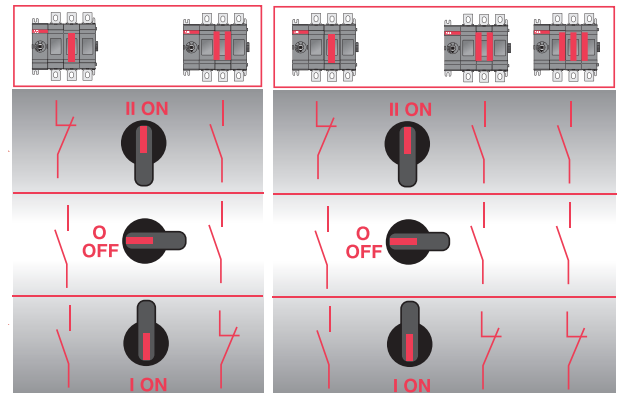

Change-over switches

By-pass switches

⊙ ≡ = Three poles





## Other configurations

### Side operated ①

### 30A – 400A, CSA fuse class J,CC,T

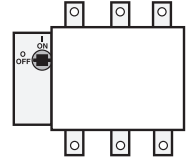

For a complete assembly,  
please select one of each:

- 1 switch
- 1 handle
- 1 shaft
- 1 terminal lug



OS30FA\_S\_



OXP6X210



OHY65J6

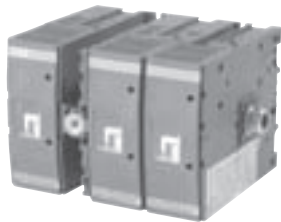

OS60JS30

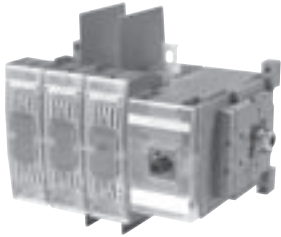

OS100JS30



OETL-ZX74



OXP12X325



OZXA-25

### Side operated switches — 3 pole

CSA general purpose amp rating	CSA fuse type 600V	Maximum horsepower rating					Catalog number	List price
		Three phase						
		200V	208V	240V	480V	600V		
30	J	5	7.5	7.5	15	20	OS30FAJS30	
30	CC	5	7.5	7.5	15	20	OS30FACCS30	
60	J	15	15	15	30	50	OS60JS30	
100	J <sup>ⓐ</sup>	25	25	30	60	75	OS100JS30	
200	J <sup>ⓐ</sup>	50	50	60	125	150	OES200J3-S	
400	J <sup>ⓐ</sup>	100	125	125	250	350	OES400J3-S	

### Handles

CSA/NEMA type	IEC type	Color	Length mm	Marking	Defeatable	Padlockable	Catalog number	List price
<b>For use with OS30A S30</b>								
1, 3R, 12	IP65	Black	2.6/65	OFF/ON	Yes	Yes	OHB65J6	
1, 3R, 12	IP65	Red/Yel	2.6/65	OFF/ON	Yes	Yes	OHY65J6	
<b>For use with OS60JS30 &amp; OS100JS30</b>								
1, 3R, 12	IP65	Black	3.1/80	OFF/ON	Yes	Yes	OHB80J6	
1, 3R, 12	IP65	Red/Yel	3.1/80	OFF/ON	Yes	Yes	OHY80J6	
<b>For use with OES200J3-S &amp; OES400J3-S</b>								
1, 3R, 12	IP65	Black	4.9/145	OFF/ON	Yes	Yes	OHB145J12	
1, 3R, 12	IP65	Red/Yel	4.9/145	OFF/ON	Yes	Yes	OHY145J12	
1, 3R, 12	IP65	Metal	4.9/145	OFF/ON	No	Yes	OETL-ZX74	

### Shafts

For use on :	Length mm	Description	Catalog number	List price
OS30FAJS30 TO OS100JS30	170	6 x 6mm	OXP6X210	
OES200J3-S & OES400J3-S	325	12 x 12mm	OXP12X325	

### Terminal lug kits

For use on:	Wire size	Weight	Wire type	Lugs per kit	Catalog number	List price
OS30AJS30 & OS30ACCS30	#18 – 8	—	Cu	—	Integral	—
OS60JS30	#14 – 4	—	Cu	—	Integral	—
OS100JS30	#14 – 2/0	0.43	Cu/Al	6	OZXA-24	
OES200J3-S	#6 – 300 kcmil	0.93	Cu/Al	6	OZXA-25	
OES400J3-S	#2 – 600 kcmil	3.50	Cu/Al	6	OZXA-26	

ⓐ J type fuse clips are standard. If 600V Type "T" fuse clips are desired, please order the "T" type fuse adapter kit.

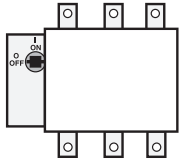

# Flange operated disconnect switches

## Cable operated fusible

### 30A – 200A



For a complete assembly, please select one each of the following

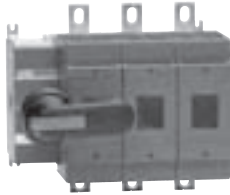

OS200J03P

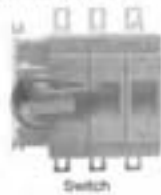

Switch



Handle

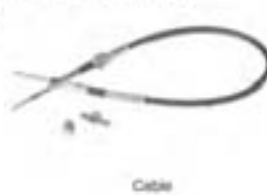

Cable



Lug kit (as required)



Operating mechanism

### 30A - 800A fusible disconnect switches

CSA general purpose amp rating A	CSA/UL fuse type 600V	Maximum horsepower rating				Poles	Catalog number	List price
		Three phase						
		200V-208V	240V	480V	600V			
30	CC	5/7.5	7.5	15	20	3	OS30FACC12	
30	J	5/7.6	7.6	15	20	3	OS30FAJ12	
60	J	15	15	30	50	3	OS60J12	
100	J/T	25	30	60	75	3	OS100AJ30	
200	J/T	50	60	125	150	3	OS200J30	



OHF1C12

### Operating mechanisms

For use on:	Catalog number	List price
OS30FAJ12, OS30FACC12 OS60J12 OS 100AJ30, OS200J30	MKCS2 MKCS3 MKCS4	



OXC1L36

### Flange handle

For use with:	Nema Type	Catalog number	List price
OS30_ - OS200J03_	1, 3R, 12	OHF1C12	
	1, 3R, 4, 4X, 12	OHF1C4	

### Cable

For use with:	Cable length (inches)	Catalog number	List price
OS30_ - OS200J03_	36	OXC1L36	
	48	OXC1L48	
	60	OXC1L60	
	72	OXC1L72	
	84	OXC1L84	
	96	OXC1L96	
	108	OXC1L108	



OZXA-200

### Terminal lug kit

For use on:	Wire size	Wire type	Lugs/kit	Catalog number	List price
OS30_ OS60J03_	#18 - 8/0	Cu	--	Integral	--
	#14 - 4	Cu	--	Integral	--
OS100AJ30-OS200J30	#4 - 300 kcmil (6) #4 - 6 AWG	Cu/Al Cu/Al	6 3	OZXA-200 OZXA-206S	



## Other configurations

### High speed fuse pattern

### Special type fuses

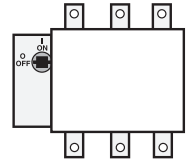

For a complete assembly, please select one of each:

- 1 switch body
- 1 adapter kit
- 1 shaft
- 1 handle

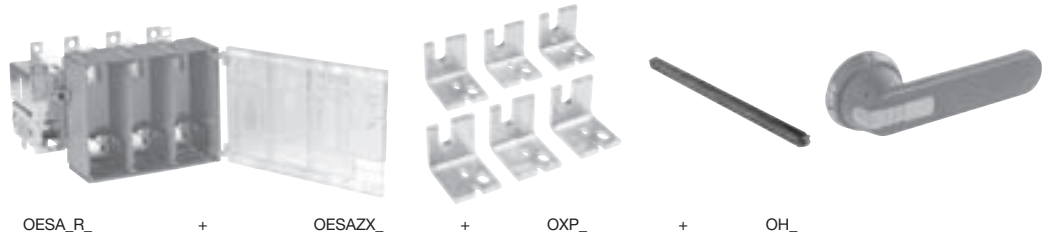

### Selecting switch bodies and adapter kits

Please select switch body and adapter kit according to your fuses. Switch body alone can not be used — an adapter kit is always needed.

#### Switch bodies – 200A through 800A

CSA general purpose amp rating	Maximum horsepower rating				Max. allowed fuse power dissipation at rated current	Catalog number	List price
	Three phase						
	208V	240V	480V	600V			
<b>3 pole</b>							
200	50	60	125	150	22W	OES200R03	
400	125	125	250	350	45W	OES400R03	
600	150	200	400	500	60W	OES600R03	
800	200	250	500	600	65W	OES800R03	
<b>4 pole</b>							
200	50	60	125	150	22W	OES200R04	
400	125	125	250	350	45W	OES400R04	
600	150	200	400	500	60W	OES600R04	
800	200	250	500	600	65W	OES800R04	

#### Fuse adapter kits — for switches OES200 - OES400

Fuse standard	For 3 pole switch		For 4 pole switch	
	Catalog number	List price	Catalog number	List price
American standard	OESAZX1-S4 OESAZX1-S5		OESAZX1-S4/4 OESAZX1-S5/4	
DIN80 (DIN43653) DIN 80 sizes 00 and 000 (DIN 43653)	OESAZX1-S7 OESAZX1-S9		OESAZX1-S7/4 OESAZX1-S9/4	
DIN110 (DIN43653) DIN140 (DIN43653)	OESAZX1-S2 OESAZX1-S6		OESAZX1-S2/4 OESAZX1-S6/4	
Flush-end, 70 mm body Flush-end, 50 mm body	OESAZX1-S8 OESAZX1-S3		OESAZX1-S8/4 OESAZX1-S3/4	
French French with micro switches	OESAZX1-S10 OESAZX1-S11		OESAZX1-S10/4 OESAZX1-S11/4	

#### Fuse adapter kits — for switches OES600 - OES800

Fuse standard	For 3 pole switch		For 4 pole switch	
	Catalog number	List price	Catalog number	List price
American standard DIN80, DIN 110, DIN 140 (DIN43653) Flush-end, 50 mm and 70 mm body	OESAZX2-S4 OESAZX2-S2 OESAZX2-S3		OESAZX2-S4/4 OESAZX2-S2/4 OESAZX2-S3/4	
French French with micro switches	OESAZX2-S5 OESAZX2-S6		OESAZX2-S5/4 OESAZX2-S6/4	

#### Handles and shafts — see pages 2.14

Selecting the right fusible disconnect for HSF fuses may be difficult. Due to CSA restrictions it is not possible to give a general fuse selection table for your use. Therefore we ask you to contact ABB, in application issues. Information needed is nominal current of the application and catalog number of the fuse

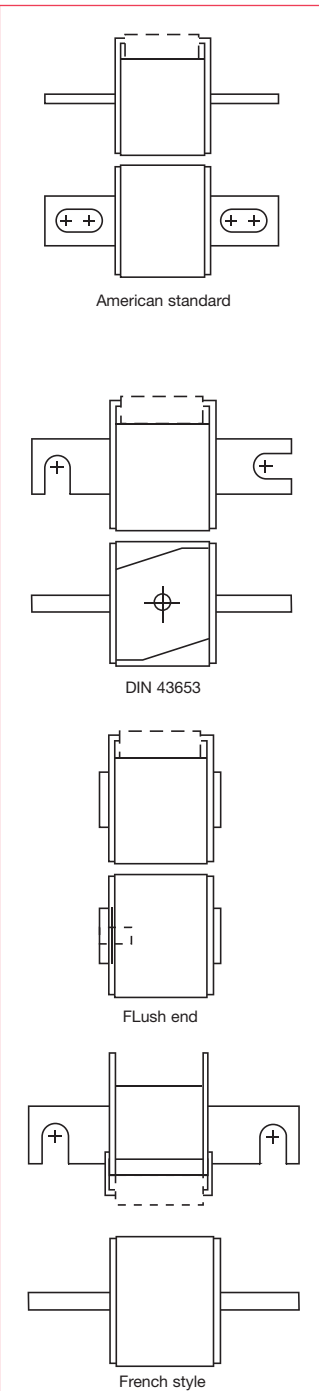

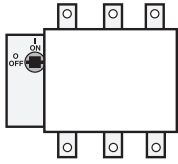

## Other configurations

### Fusible switches, DIN-Type

### 32A – 800A



OS63D12

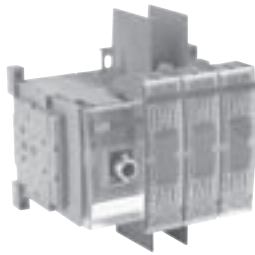

OS160

#### Fusible switches, DIN - Type (32A - 800A)

Handle and shaft included

Rated current	AC23A rated operational power in kW			Fuse type	Catalog number	List price
	400V	500V	690V			
<b>3 pole</b>						
32	15	18.5	22	000, 00	OS32FD12	
63	30	37	55	000, 00	OS63D12	
125	55	75	110	000, 00	OS125D12	
160	75	90	132	000, 00	OS160D12	
200	110	132	200	0	OS200D12P	
250	140	170	250	0, 1	OS250D12P	
400	220	280	400	0, 2	OS400D12P	
630	355	450	560	3	OS630D12P	
800	400	500	710	3	OS800D12P	
<b>4 pole</b>						
32	15	18.5	22	000, 00	OS32FD22F	
63	30	37	55	000, 00	OS63D22F	
125	55	75	110	000, 00	OS125D22F	
160	75	90	132	000, 00	OS160D22F	
200	110	132	200	0	OS200D22N2P	
250	140	170	250	0, 1	OS250D22N2P	
400	220	280	400	0, 2	OS400D22N2P	
630	355	450	560	3	OS630D22N2P	
800	400	500	710	3	OS800D22N2P	



DIN fuses are mainly used in continental Europe (excluding France below 125A), Asia, Africa and South-America

ⓘ Please consult factory for additional information.



## Other configurations

### Fusible switches, NFC-Type

#### 63A – 125A, 14x51 & 22x58

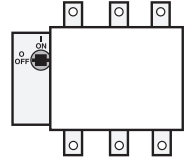

OS32FF1214



OS63F12



OS125F03

#### Fusible switches, NFC-Type

Handle and shaft included

Rated current	AC23A rated operational power in kW			Fuse type	Catalog number	List price
	400V	500V	690V			
<b>3 pole</b>						
25	11	15	22	10x38	OS25FF1210	
32	11	18.5	22	14x51	OS32FF1214	
50	20	30	37	14x51	OS50F12	
63	30	37	55	22x58	OS63F12	
100	55	55	90	22x58	OS100F12	
125	55	75	110	22x58	OS125F12	
<b>4 pole</b>						
25	11	15	22	10x38	OS25FF2210N1	
32	11	18.5	22	14x51	OS32FF2214N1	
50	20	30	37	14x51	OS50F22N1	
63	30	37	55	22x58	OS63F22N1	
100	55	55	90	22x58	OS100F22N1	
125	55	75	110	22x58	OS125F22N1	



NFC fuses are used in France and in French speaking Africa

ⓘ Please consult factory for additional information.

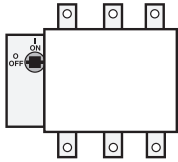

## Other configurations

### Fusible switches, BS-Type

#### 20A – 800A

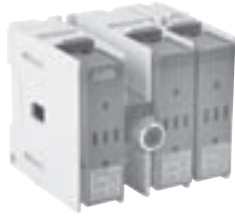

OS32FB12A1



OS63B12

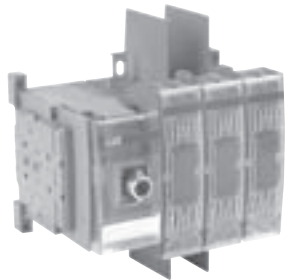

OS160

### Fusible switches, BS - Type

Handle and shaft included

Rated current	AC23A rated operational power in kW			Fuse type	Catalog number	List price
	230V	400V	690V			
<b>3 pole</b>						
20	7.5	11	15	A1	OS20FB12A1	
32	11	18.5	22	A2, A3	OS32FB12	
63	30	37	55	A2, A3	OS63B12	
100	55	55	90	A2, A3	OS100B12	
125	55	75	110	A2, A3, A4	OS125B12	
160	75	90	132	A2, A3, A4	OS160B12	
200	110	132	200	B1, B2	OS200B12P	
250	140	170	250	B1-B3	OS250B12P	
315	160	220	220	B1-B4	OS315B12P	
400	220	280	400	B1-B4	OS400B12P	
630	355	450	560	C1, C2	OS630B12P	
800	400	500	710	C1-C3	OS800B12P	
<b>4 pole</b>						
20	7.5	11	15	A1	OS20FB22A1N1	
32	11	18.5	22	A2, A3	OS32FB22N1	
63	30	37	55	A2, A3	OS63B22N1	
100	55	55	90	A2, A3	OS100B22N1	
125	55	75	110	A2, A3, A4	OS125B22N1	
160	75	90	132	A2, A3, A4	OS160B22N1	
200	110	132	200	B1, B2	OS200B22N2P	
250	140	170	250	B1, B3	OS250B22N2P	
315	160	220	220	B1, B4	OS315B22N2P	
400	220	280	400	B1, B4	OS400B22N2P	
630	355	450	560	C1, C2	OS630B22N2P	
800	400	500	710	C1, C3	OS800B22N2P	



BS fuses are widely used in UK, South-Africa, Australia and Hong Kong



## Other configurations

### Global concept disconnect switches

#### 32A – 60A

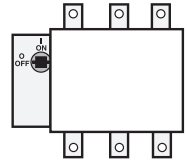

For a complete assembly, please select one of each:

- 1 fusible disconnect body
- 1 set of fuse carriers
- 1 shaft
- 1 handle

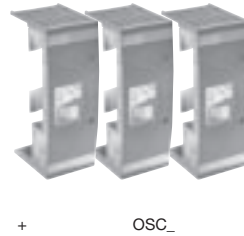

OS63X12

+

OSC\_

+

OX\_

+

OH\_

#### About the global concept ...

##### Customers in Boston and Berlin?

Do your customers in Boston prefer UL Class J fuses and your customers in Berlin specify DIN standard fuses? No problem!

ABB Global concept fusible disconnect switches offer the flexibility to design a panel using a common disconnect

body. When the panel destination is known, simply insert the appropriate fuse carrier.

Global concept = common disconnect body + an assortment of fuse carriers.

High volumes with various fuse types — Global concept.

#### Fusible disconnect bodies — 30A & 60A

UL general purpose amp rating	IEC AC21 amp rating	Description	Catalog number	List price
30	32	3 pole	OS32M12 OS32M22F OS32M22N1 <sup>①</sup> OS32MS30 OS32MS40F OS32MS40N1 <sup>①</sup>	
		4 pole		
		3 pole + neutral		
		3 pole, side operation		
		4 pole, side operation		
60	63	3 pole + neutral, side operation	OS63X12 OS63X22F OS63X22N1 <sup>①</sup> OS63XS30 OS63XS40F OS63XS40N1 <sup>①</sup>	
		3 pole		
		4 pole		
		3 pole + neutral		
		3 pole, side operation		
4 pole, side operation				
3 pole + neutral, side operation				

#### Fuse carriers for 3 pole units and units with neutral <sup>②</sup>

For use on:	Fuse type	Catalog number	List price
OS32M_	UL J 30A	OSC30AJ3 OSC30ACC3 OSC16D301 OSC35D302 OSC25F310 OSC32F314 OSC32B3A1 OSC32B3A2 OSC32B3E1 OSC32B3F1	
	UL CC 30A		
	DIN Neozed D01		
	DIN Neozed D02		
	NFC 10x38		
	NFC 14x51		
	BS88 A1		
	BS88 A2		
	BS88 E1		
	BS88 F1		
OS63X_	UL J 60A	OSC60J3 OSC50F3 OSC63F3 OSC63B3 OSC63D3	
	NFC 14x51		
	NFC 22x58		
	BS88 A2, A3 CSA C30, C60		
	DIN 000, 00		

#### Fuse carriers for 4 pole units <sup>③</sup>

For use on:	Fuse type	Catalog number	List price
OS32M_	UL J 30A	OSC30AJ4 OSC30ACC4 OSC16D401 OSC35D402 OSC25F410 OSC32F414 OSC32B4A1 OSC32B4A2 OSC32B4E1 OSC32B4F1	
	UL CC 30A		
	DIN Neozed D01		
	DIN Neozed D02		
	NFC 10x38		
	NFC 14x51		
	BS88 A1		
	BS88 A2		
	BS88 E1		
	BS88 F1		
OS63X_	UL J 60A	OSC60J4 OSC50F4 OSC63F4 OSC63B4 OSC63D4	
	NFC 14x51		
	NFC 22x58		
	BS88 A2, A3 CSA C30, C60		
	DIN 000, 00		

NOTE: Handles and shafts — see pages 2.8 for OS32\_ and page 2.10 for OS63\_.

<sup>①</sup> N1-versions will be delivered with neutral carrier.

<sup>②</sup> Part number includes 3 pieces of fuse carriers.

<sup>③</sup> Part number includes 4 pieces of fuse carriers.







# CSA & UL Technical data for fusible disconnect switches OS30 – OS1200L03

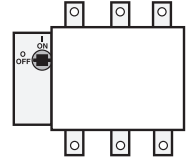

## CSA & UL

Catalog number	3 pole	OS30FAJ12	OS60J12	OS100J12	OS200J03	OS400J03	OS600J03	OS800L03	OS1200L03
Approvals <sup>①</sup>	2 pole	N/A	N/A	CSA C22.2 No.4	CSA C22.2 No.4	CSA C22.2 No.4	CSA C22.2 No.4	CSA C22.2 No.4	CSA C22.2 No.4
	3 pole	CSA C22.2 No.4	CSA C22.2 No.4	CSA C22.2 No.4	CSA C22.2 No.4	CSA C22.2 No.4	CSA C22.2 No.4	CSA C22.2 No.4	CSA C22.2 No.4
	4 pole	CSA C22.2 No.4	CSA C22.2 No.4	CSA C22.2 No.4	CSA C22.2 No.4	CSA C22.2 No.4	CSA C22.2 No.4	CSA C22.2 No.4	CSA C22.2 No.4
<b>Technical ratings</b>	40°C								
General purpose amp rating pf = 0.7 – 0.8	<b>A</b>	<b>30</b>	<b>60</b>	<b>100</b>	<b>200</b>	<b>400</b>	<b>600</b>	<b>800</b>	<b>1200</b>
Max operating voltage	V	600	600	600	600	600	600	600	600
Max horsepower rating/ Max motor FLA current pf = 0.4 – 0.5									
Three phase									
208V	HP/A	7.5/24	15/46	25/75	50/150	100/300	150/396	150/396	—
240V	HP/A	7.5/22	15/42	30/80	60/154	125/312	200/480	200/480	—
480V	HP/A	15/21	30/40	60/77	120/156	250/302	400/477	500/590	—
600V	HP/A	20/22	50/52	75/77	150/144	350/336	500/472	500/472	—
Single phase									
120V	HP/A	2/24	—	—	—	—	—	—	—
240V	HP/A	3/17	—	—	—	—	—	—	—
Short circuit rating with fuse	kA	200	200	200	200	200	200	200	200
CSA Fuse size	A	30	60	100	200	400	600	800	1200
CSA Fuse type		J/CC	J	J/T	J/T	J/T	J/T	L	L
<b>Endurances</b>									
Min. Electrical endurance, pf = 0.75 – 0.80 operation cycles		6000	6000	6000	6000	1000	1000	500	500
Mechanical endurance operation		20,000	20,000	20,000	16,000	12,000	4000	3000	3000
<b>Physical characteristics</b>									
Weight	3 pole Kg	0.7	1.3	1.5	2.6	5.7	11.5	11.5	29
	4 pole Kg	0.9	1.6	1.8	3.2	6.9	14	14	36
Dimension 3 pole	H mm	97	100	144	200	230	306	306	287
	W mm	106	145	180	182	255	343	343	429
	D mm	107	128	120	132	176	233	233	294
Shaft size square □	mm	5 x 5	6 x 6	6 x 6	6 x 6	12 x 12	12 x 12	12 x 12	12 x 12
Switch operating torque for rotary 3 pole switches	lb. in.	26	35	70	—	195	248	248	—
<b>Terminal lug kits</b>		Standard	Standard	OZXA-24	OZXA-200	OZXA-400	OZXA-800	OZXA-800	OZXA-1200
Wire range AWG	#18 – #8	#14 – #4	#14 – 2/0	#4 – 300 kcmil	#2 – 600 kcmil	(2) #2 – 600 kcmil	(2) #2 – 600 kcmil	(2) #2 – 600 kcmil	(4) #2 – 600 kcmil
Torque:									
Wire tightening	lb. in.	17	30	120	275	500	500	500	500
Lug mounting	lb. in.	Integral	Integral	50	150	480	480	480	480
<b>Auxiliary contacts</b>		OA_G_	OA_G_	OA_G_	OA_G_	OA_G_	OA_G_	OA_G_	OA_G_
NEMA ratings, AC		A600	A600	A600	A600	A600	A600	A600	A600
AC rated voltage	VAC	600	600	600	600	600	600	600	600
AC thermal rated current	A	10	10	10	10	10	10	10	10
AC maximum volt ampere making	VA	7200	7200	7200	7200	7200	7200	7200	7200
AC maximum volt ampere breaking	VA	720	720	720	720	720	720	720	720
NEMA ratings, DC		R300	R300	R300	P600	P600	P600	P600	P600
DC rated voltage	VDC	300	300	300	600	600	600	600	600
DC thermal rated current	A	1	1	1	1	1	7	7	7
DC maximum make break current	A	28	28	28	28	28	28	28	28
Torque:									
Wire tightening	lb. in.	7	7	7	7	7	7	7	7
Wire range AWG		#18 – #14	#18 – #14	#18 – #14	#18 – #14	#18 – #14	#18 – #14	#18 – #14	#18 – #14

① The following CSA approved switches are also UL Listed.

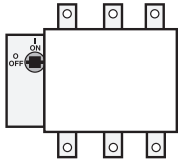

# IEC Technical data

## Fusible disconnect switches

### OS30 – OS1200L03



#### IEC

Catalog number	3 pole	OS30FA_12	OS60J12	OS100J03	OS200J03	OS400J03	OS600J03	OS800L03	OS1200L03
Technical ratings	-40° to 40°C								
Rated insulation voltage		1000	1000	1000	1000	1000	1000	1000	1000
Pollution degree 3 ③	V								
Dielectric strength 50Hz/60Hz, 1 min	kV	10	10	10	10	10	10	10	10
Rated impulse withstand voltage	kV	12	12	12	12	12	12	12	12
Rated thermal current, I <sub>t</sub> /max. fuse power dissipation ①									
AC 20/DC 20 open ②	A/W	32/3.5	63/7.5	160/12	200/17	400/45	630/60	800/65	
40°C enclosed	A/W	32/3.5	63/7.5	160/10, 135/12	200/17	400/34, 360/37	600/45, 570/50	720/55	
Enclosed with solid links	A/W	32	85	175	280	450	700	900	
with minimum cable cross section Cu	mm <sup>2</sup>	6	16	70	95	240	2 x 185	2 x 240	
Rated operational voltage AC 20 and DC 20V		1000	1000	1000	1000	1000	1000	1000	1000
<b>AC Rated operational currents</b>									
AC 21A	≤500V A	32	63	160	200	400	630	800	1250
	≤690V A	32	63	160	200	400	630	800	1250
AC 22A	≤500V A	32	63	160	200	400	630	800	1250
	≤690V A	32	63	160	200	400	630	800	1250
AC 23A	≤500V A	32	63	160	200	400	630	800	1000
	≤690V A	32	63 ⑤	160 ⑤	200	400	630	800	1000
<b>DC Rated operational currents/poles in series</b>									
DC21A	48V A	32/2	63/2	160/2	200/1	400/2			
	110V A	32/2	63/3	160/2	200/1	400/2			
	220V A	32/2	63/3	160/2	200/1	400/2			
	440V A	32/4	63/4	160/3	200/2	400/3			
	750V A	—	—	—	180/4	400/4			
	1000V A	—	—	—	—	—			
DC22A	48V A	32/2	63/2	160/2	200/1	400/2			
	110V A	32/2	63/3	160/2	200/1	400/2			
	220V A	32/2	63/3	160/2	200/1	400/2			
	440V A	32/4	63/4	160/3	200/2	400/3			
	750V A	—	—	—	180/4	400/4			
	1000V A	—	—	—	—	—			
DC23A	48V A	32/2	63/2	160/2	200/1	400/2			
	110V A	32/2	63/3	160/2	200/1	400/2			
	220V A	32/2	63/3	160/2	200/1	400/2			
	440V A	32/4	63/4	125/4	200/2	400/3			
	750V A	—	—	—	180/4	400/4			
	1000V A	—	—	—	—	—			
<b>Rated operational power AC23A</b>									
	230V kW	7.5	18.5	45	60	132	200	250	315
	400V kW	15	30	75	110	220	355	450	560
	415V kW	15	30	75	110	230	355	450	560
	500V kW	18.5	37	90	132	280	450	560	710
	690V kW	22	55	132	200	400	630	710	1000



Figure 1

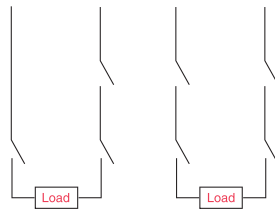

Figure 2

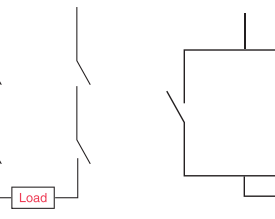
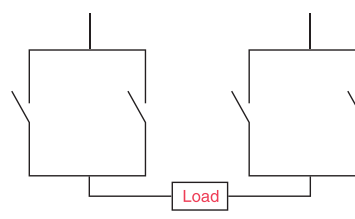

Figure 3



- ① Ambient temperature 60°C: derating 20 percent. Mounting on ceiling: derating 10 percent. Mounting on wall, horizontal fuses: derating 8 percent.
- ② The ambient air temperature does not exceed +40°C and its average over a period of 24h does not exceed +35°C according to IEC 947.
- ③ For 30A switches, use 2 + 2 parallel contacts in series.
- ④ Available on request.
- ⑤ IEC 947-3, utilization category B, infrequent operation.
- ⑥ Pollution degree 3: Conductive pollution occurs, or dry, non-conductive pollution occurs, which becomes conductive due to condensation.



# IEC Technical data

## Fusible disconnect switches

### OS30 – OS1200L03

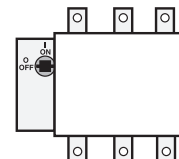

Catalog number	3 pole	OS30FA 12	OS60J12	OS100J03	OS200J03	OS400J03	OS600J03	OS800L03	OS1200L03
<b>Rated breaking capacity</b>									
in category AC-23A	500V	A	256	504	1280	1600	3200	5760	5760
	690V	A	256	504	1280	1600	3200	5760	5760
<b>Rated breaking capacity/poles in series</b>									
in category DC-23	<220V	A	128/2	—	—	1000/2	1600/2	3200/2	3200/2
	440V	A	128/4	—	—	1000/2	1600/2	3200/2	3200/2
	500 – 750V	A	—	—	—	1000/3	1600/3	3200/3	3200/3
	1000V	A	—	—	—	—	3200/4	3200/4	3200/4
<b>Rated conditional short-circuit current <i>r.m.s.</i> <sup>③</sup></b>									
	80 kA, 415V	kA	9	17	22	35	40	75	75
	100 kA, 500 V	kA	7.5	17	22	37.5	40	75	75
	50 kA, 690 V	kA	6	13	15	35	35	60	60
	Rated short time withstand current, 1s.	kA	1	2.5	5	8	10	16	16
<b>Rated capacitor power</b>									
The capacitor rating of the fusible disconnect switch is limited by the fuse link									
	400 V	kVar	15	30	—	—	180	250	310
	415V	kVar	15	32	—	—	200	270	340
	690V	kVar	25	50	—	—	325	450	550
<b>Power loss/pole with rated current, without fuse</b>									
	operations	W	2	4	9	8	30	46	75
<b>Mechanical endurance</b>									
	operations		20,000	20,000	20,000	20,000	16,000	4000	3000
<b>Fuse types, IEC 269-2</b>									
	DIN 43620	—	—	000, 00	000, 00	0 – 1	0 – 2	3	3
	NFC	10 x 38, 14 x 51	14 x 51, 22 x 58	22 x 58	0 – 1	0 – 2	3	3	3
	BS 88	A1, A2, F1	A2 – A3	A2 – A4	B1 – B2	B1 – B4	C1 – C2	C1 – C3	D1
<b>size/distance of link bolts</b>									
		M4/44.5(A1) M5/73(A2)	M5/73	M5/73 M8/94	M6/111	M8/111	M10/133, 184	M10/133, 184	2xM12/149
<b>Physical characteristics</b>									
<b>Weight</b>									
	3 pole	kg	0.7	1.3	1.5	2.6	5.7	13	13
	4 pole	kg	0.9	1.6	1.8	3.2	6.9	17	17
<b>Dimension</b>									
	3 pole	H mm	93	100	144	200	226	306	306
		W mm	106	143	179	182	286	343	343
		D mm	104	120	129	132	198	233	233
<b>Shaft size</b>									
	square	mm	5 x 5	6 x 6	6 x 6	6 x 6	12 x 12	12 x 12	12 x 12
<b>Terminals</b>									
<b>Built-in terminal size mm<sup>2</sup></b>									
			0.5 – 10	2.5 – 25	—	—	—	—	—
<b>Terminal bolt size, metric thread diameter x length mm</b>									
			—	—	M6 x 20	M8 x 25	M10 x 40	M12 x 40	M12 x 40
<b>Terminal bolt tightening torque</b>									
		Nm	2	3.5	6 – 9	15 – 22	30 – 44	50 – 75	50 – 75
<b>Fuse-links bolts tightening torque</b>									
		Nm	2	3.5	3.5 – 5	4	15	40	—
<b>Operating torque</b>									
		Nm	3	4	8	7	22	28	28
<b>Auxiliary contacts</b>									
			OA4G_	OA1/3G	OA_G_	OA_G_	OA_G_	OA_G_	OA_G_
<b>Ratings according to IEC 947-5-1</b>									
<b>Rated voltage, U<sub>i</sub></b>									
	VAC		690	690	690	690	690	690	690
<b>Thermal current, I<sub>th</sub></b>									
	A		10	16	16	16	16	16	16
<b>AC12 / DC12, I<sub>b</sub></b>									
	U <sub>e</sub> =24V	A	— / 6	—	—	—	—	—	—
	120V	A	— / 6	—	—	—	—	—	—
	125V	A	—	—	—	—	—	—	—
	230V	A	—	6 / —	6 / —	6 / —	6 / —	6 / —	6 / —
	250V	A	3 / 0.1	—	—	—	—	—	—
	400V	A	—	4 / —	4 / —	4 / —	—	—	—
	415V	A	—	—	—	—	—	—	—
	440V	A	2 / —	—	—	—	—	—	—
	480V	A	—	—	—	—	—	—	—
	500V	A	—	—	—	—	—	—	—
	600V	A	—	—	—	—	—	—	—
	690V	A	—	2 / —	2 / —	2 / —	2 / —	2 / —	2 / —

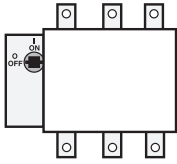

# Auxiliary contact timing diagrams

## OS30\_ – OS100



- The handle indicates the position of the contacts with complete reliability in all situations. If the contacts are welded together, the handle doesn't reach the OFF-position but remains between ON and OFF, maintaining the door interlock and padlocking is not possible to do.
- When operating the switch to the Test-position with a test handle the test auxiliary contacts change position. The main contacts remain open.

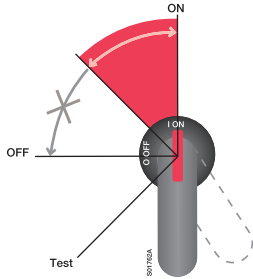

### ON and OFF-functions of main and auxiliary contacts

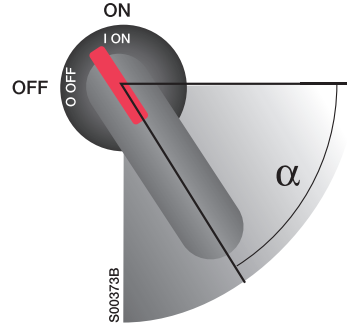

#### Closing

1. Main contacts close
2. NO auxiliary contacts close
3. NC auxiliary contacts open

#### Opening

4. Main contacts open
5. NO auxiliary contacts open
6. NC auxiliary contacts close

### OS 30\_

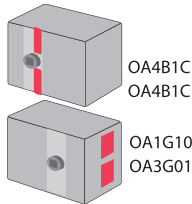

Main contacts  
NO auxiliary contact  
NC auxiliary contact

NO auxiliary contact  
NC auxiliary contact

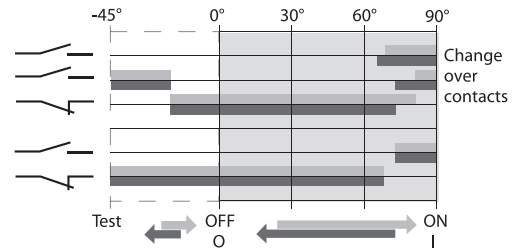

### OS 60\_

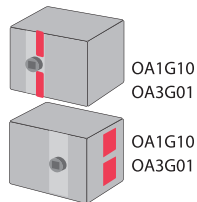

Main contacts  
NO auxiliary contact  
NC auxiliary contact

NO auxiliary contact  
NC auxiliary contact

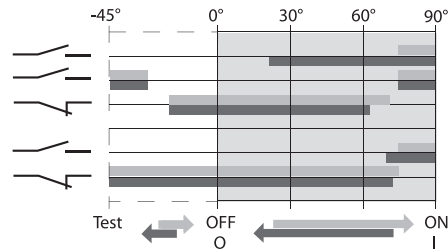

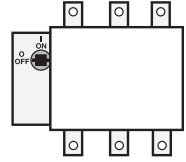

### OS 100\_

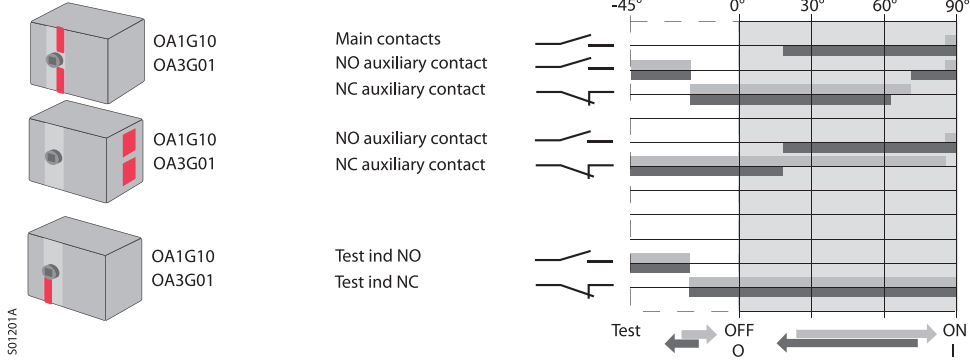

### OS200-1200

### ON and OFF-fuctions of main and auxiliary contacts

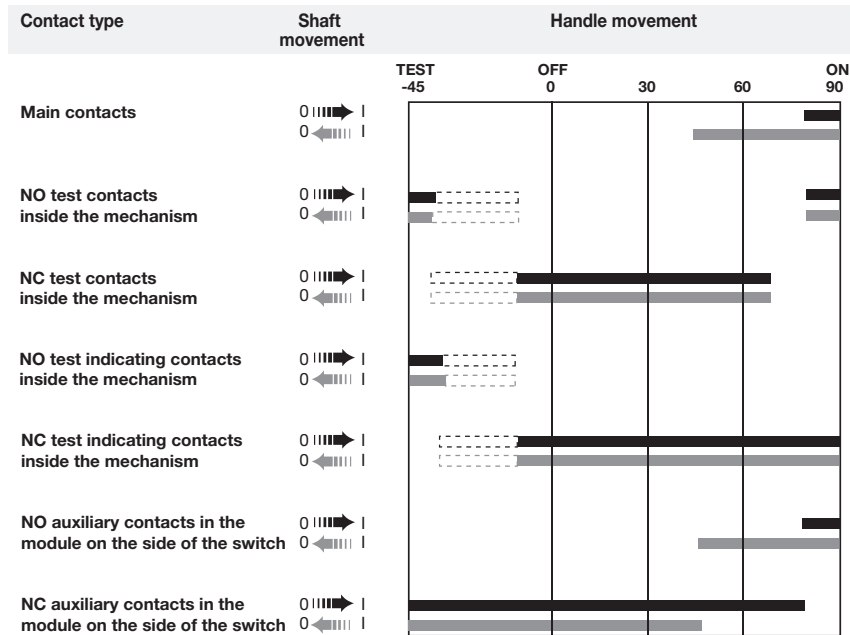

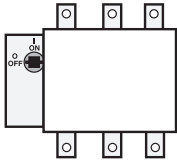

# Approximate dimensions

## Fusible disconnect switches

### OS30\_ - OS60\_



#### OS30FA

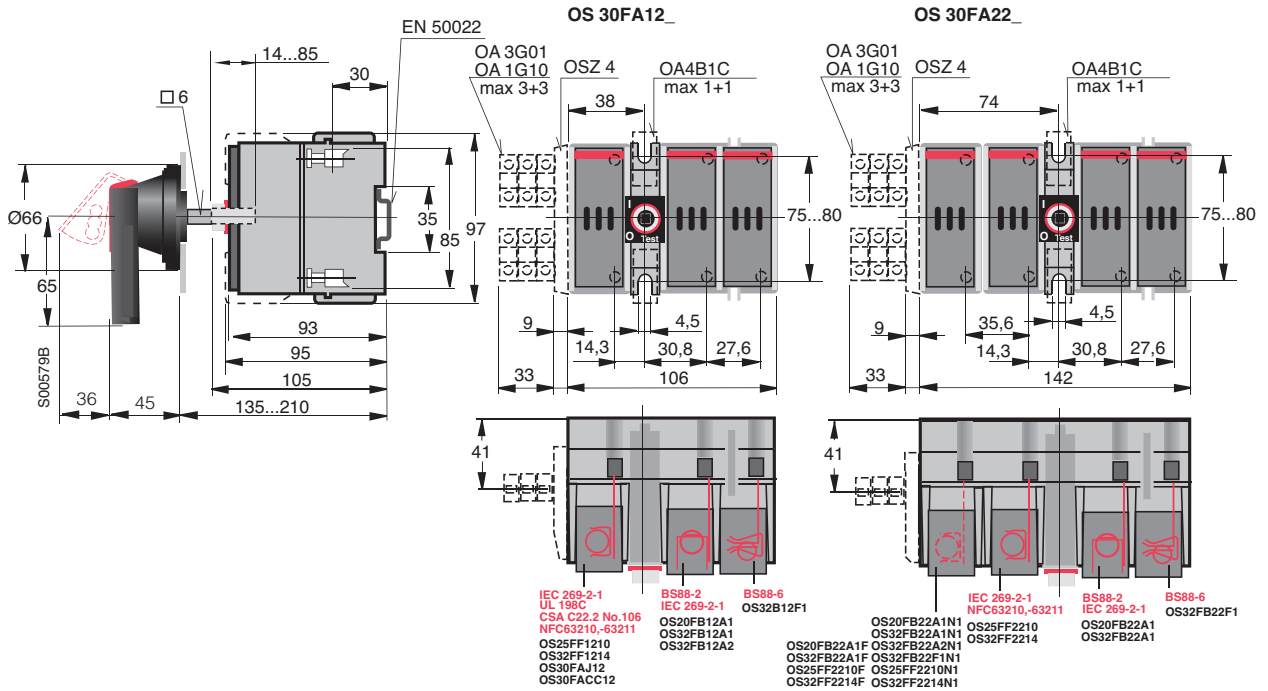

#### OS60

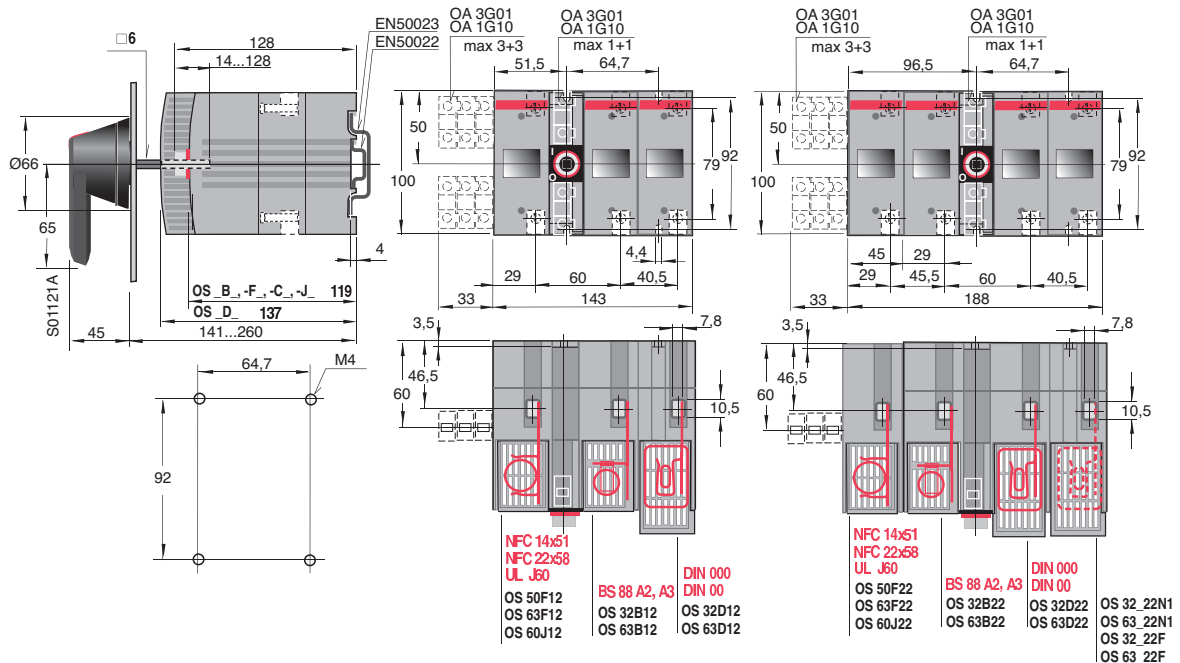



# Approximate dimensions Fusible disconnect switches OS100J12, J03

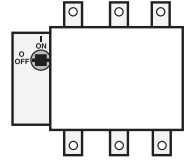

## OS100J12, OS100J22

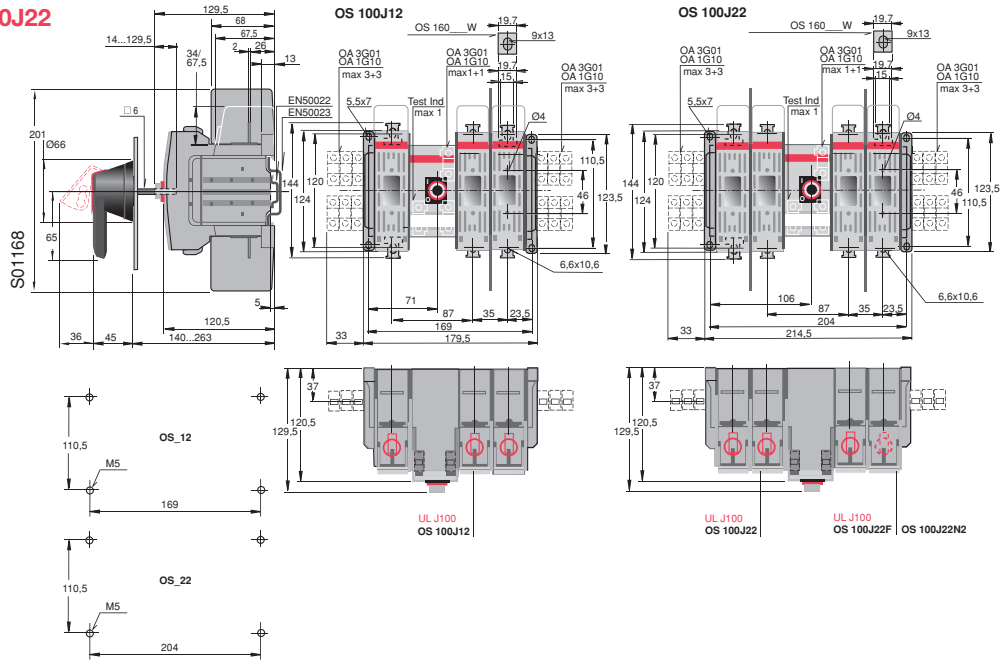

## OS100J03, OS100J04

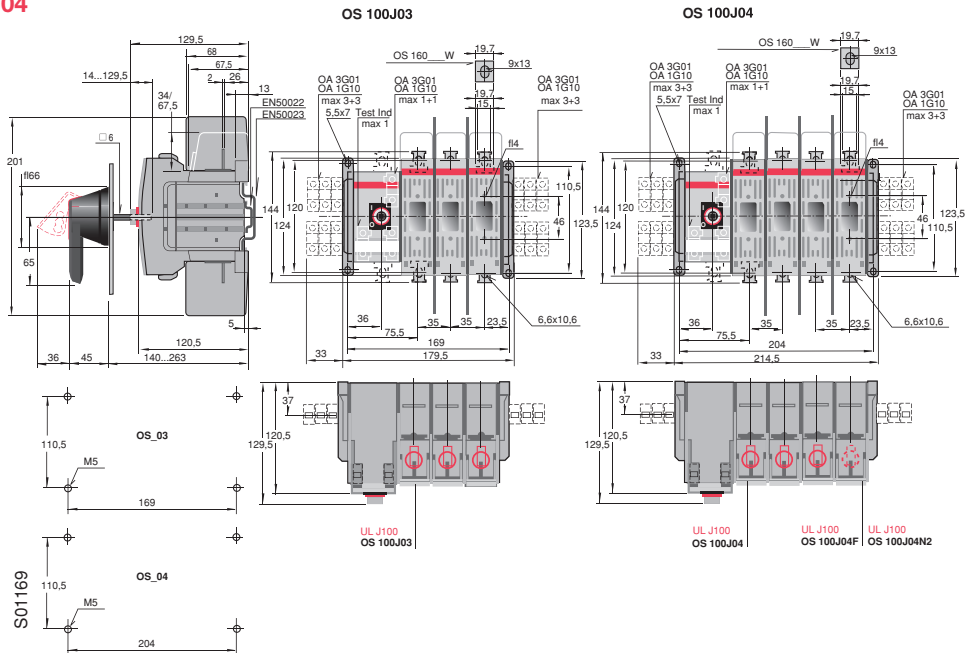

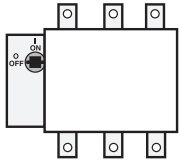

# Approximate dimensions

## Fusible disconnect switches

### OS200 – OS400



### OS200J

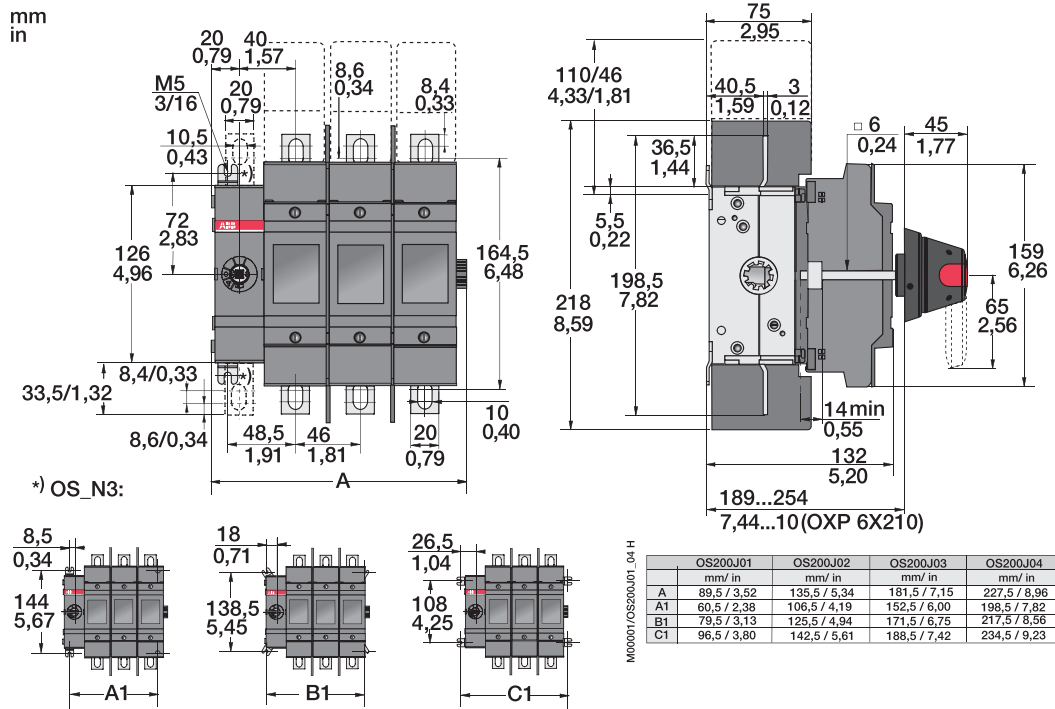

### OS400J

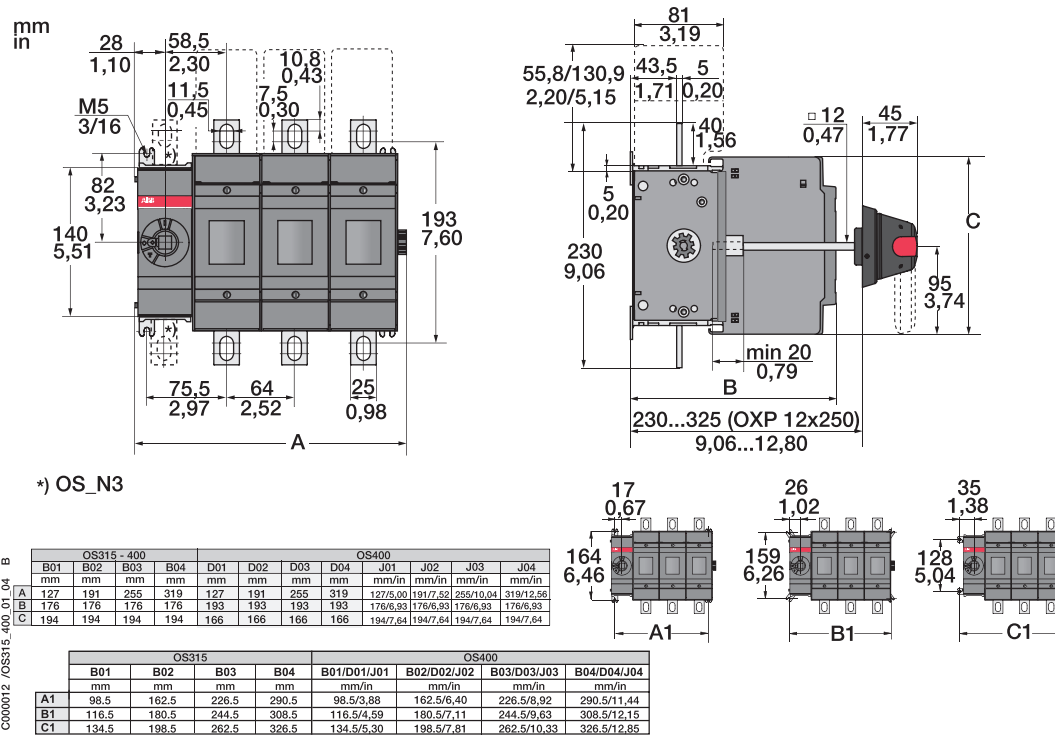



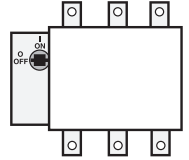

#### OS600J03-OS800L03

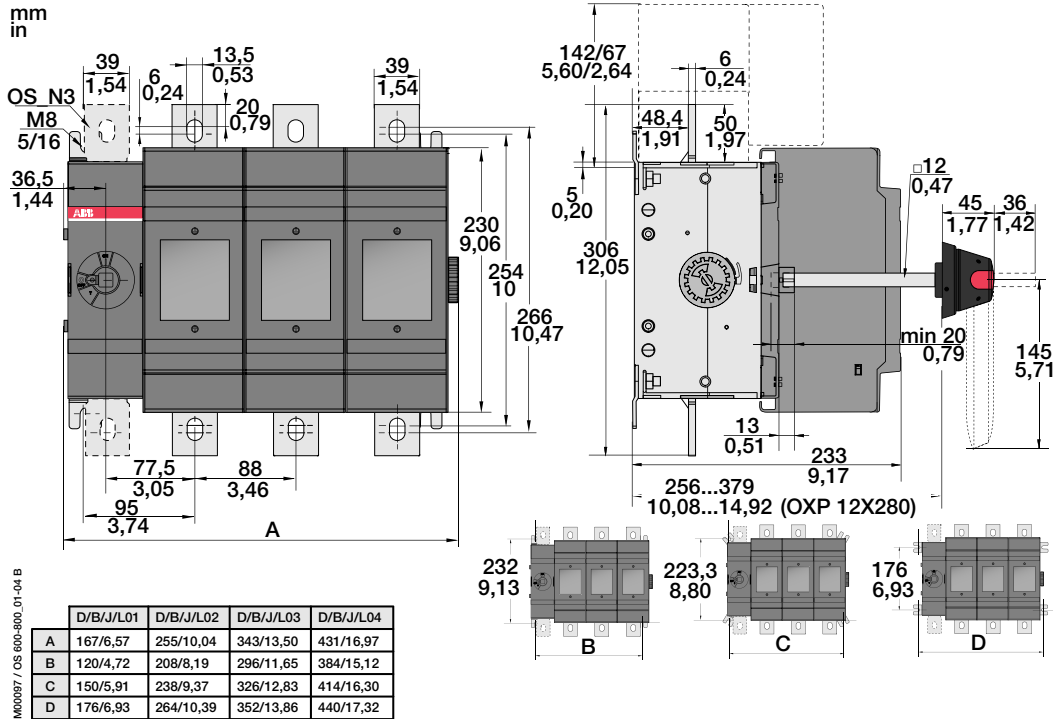

#### OS1200L03

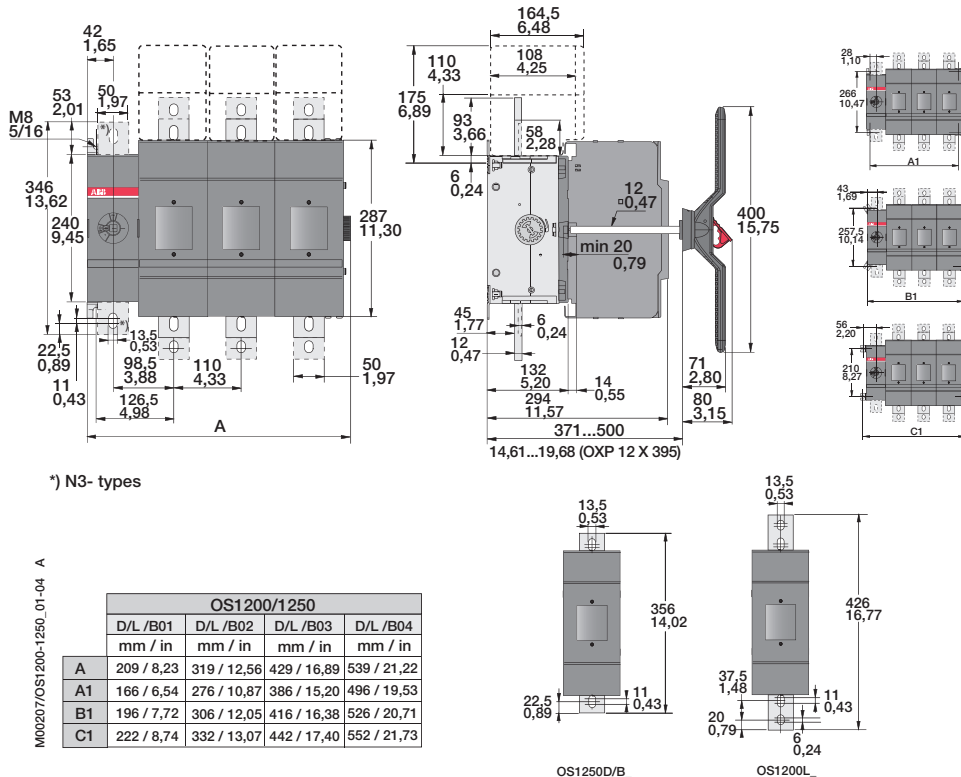

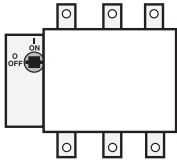

## Approximate dimensions 30A Conversion mechanisms



### 6 pole — OWP6DS1

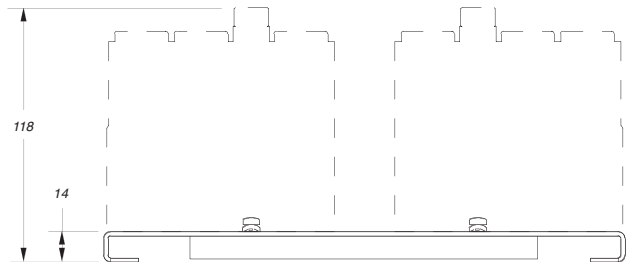
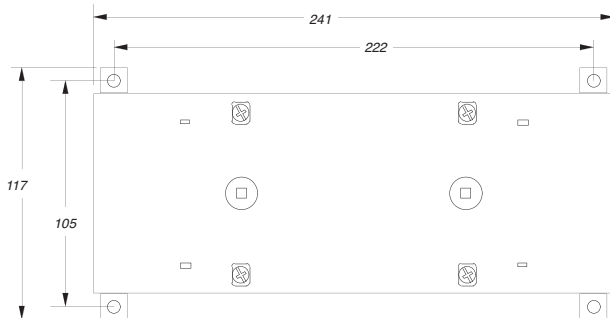

For installation of 6 or 8 pole mechanisms, the following minimum and maximum mounting dimensions are given below.

OWP6DS1 in combination with:	Minimum mm	Maximum mm
OS30_	140	N/A

### Transfer switch — OWC6DSH1

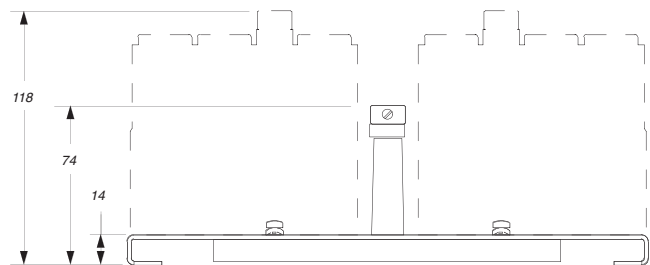
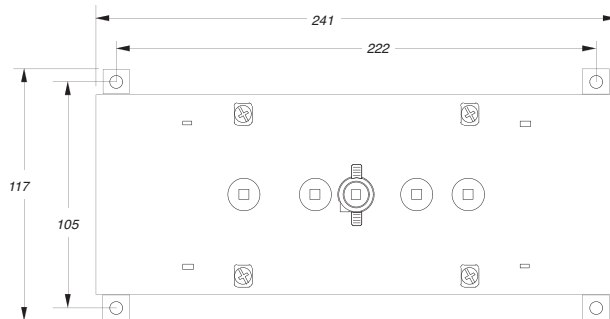

For installation of 6 or 8 pole mechanisms, the following minimum and maximum mounting dimensions are given below.

OWC6DSH1 in combination with:	Minimum mm	Maximum /mm
OS30_	140	N/A

### Mechanical interlock — OWM6DS1

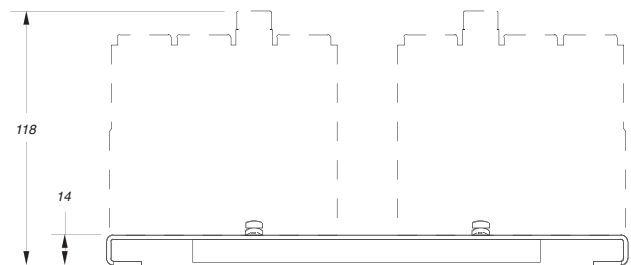
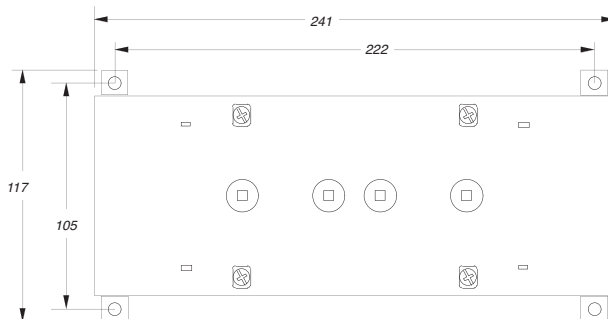

For installation of 6 or 8 pole mechanisms, the following minimum and maximum mounting dimensions are given below.

OWM6DS1 in combination with:	Minimum mm	Maximum mm
OS30_	140	N/A

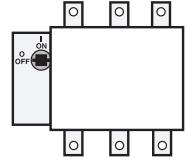

### 6 or 8 pole — OESA-ZW2

For installation of 6 or 8 pole and transfer mechanisms, the following minimum and maximum mounting dimensions are given below.

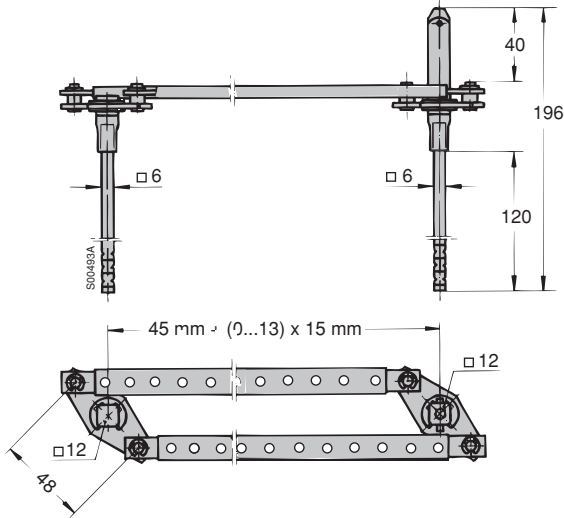

OESA-ZW2 in combination with:	Minimum mm	Maximum mm
OS60	175	275
OS100	175	275

Note: Deeper enclosures will require a longer shaft, please select a 12mm shaft from page 2.25, and an OETL-ZX95 shaft extension coupler from page 2.21.

### Transfer switch — OESA-ZW1

OESA-ZW1 in combination with:	Minimum mm	Maximum mm
OS60	200	336
OS100	210	336

Note: Deeper enclosures will require a longer shaft, please select a 6mm shaft from page 2.19.

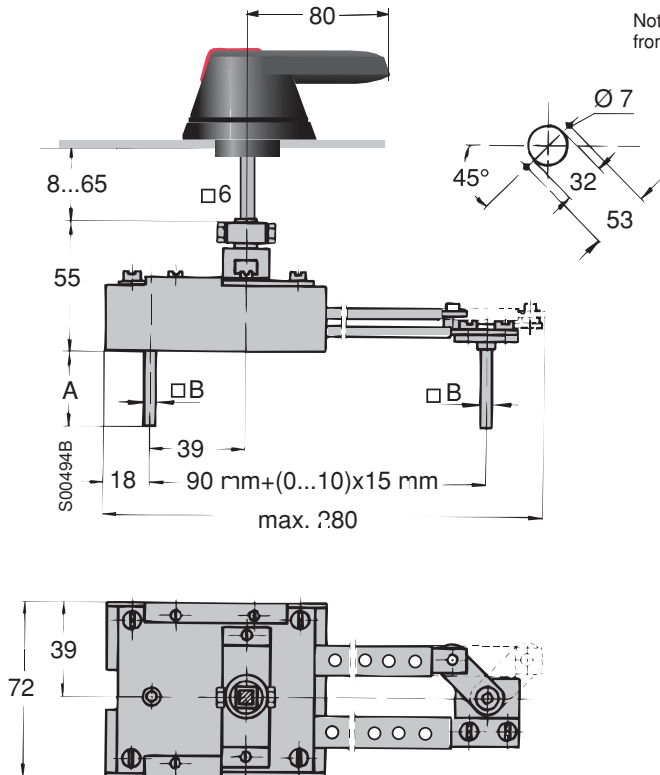

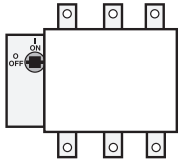

# Approximate dimensions 200A – 800A Conversion mechanisms



## 6 or 8 pole — OETL-ZW9

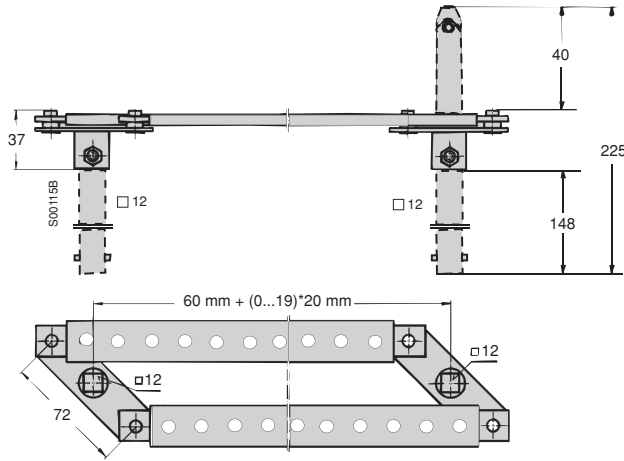

## Mechanical Interlock — OETL-ZW15

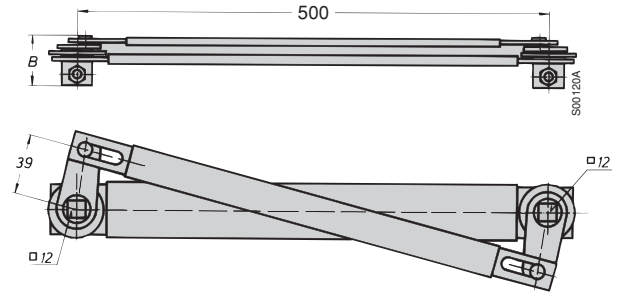

## Transfer switch — OETL-ZW12

## Bypass switch — OETL-ZW13

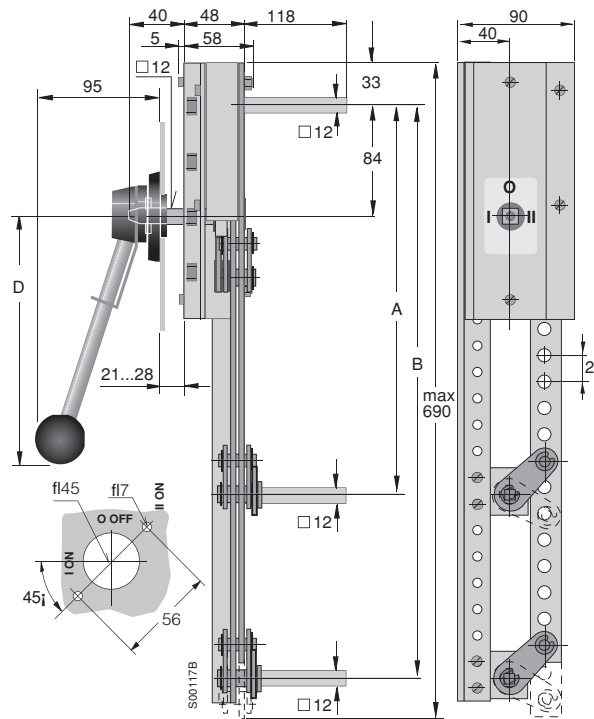

	A	B	D
OETLZW 12	210+(0...18)x20 mm		220 mm
OETLZW 13	210+(0...18)x20 mm	250+(0...18)x20 mm	320 mm



# Fuse monitor

## Contact functions

## Dimension drawings

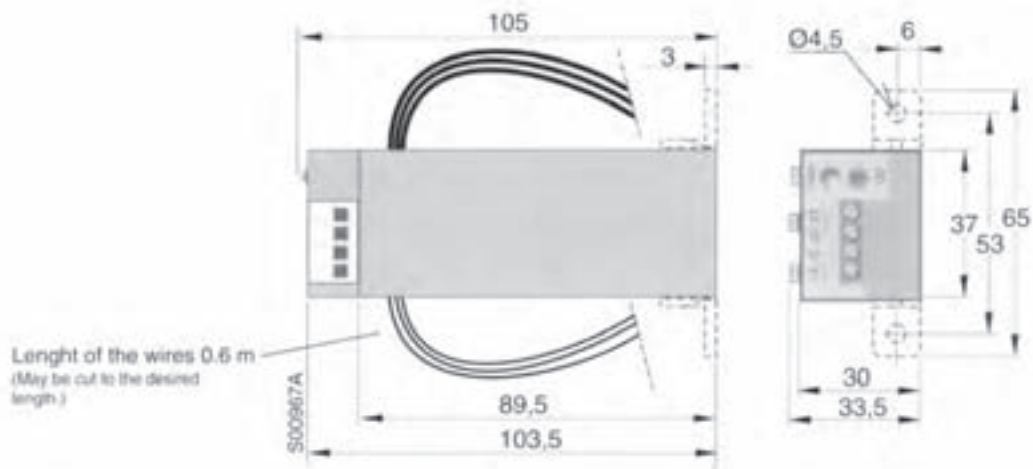
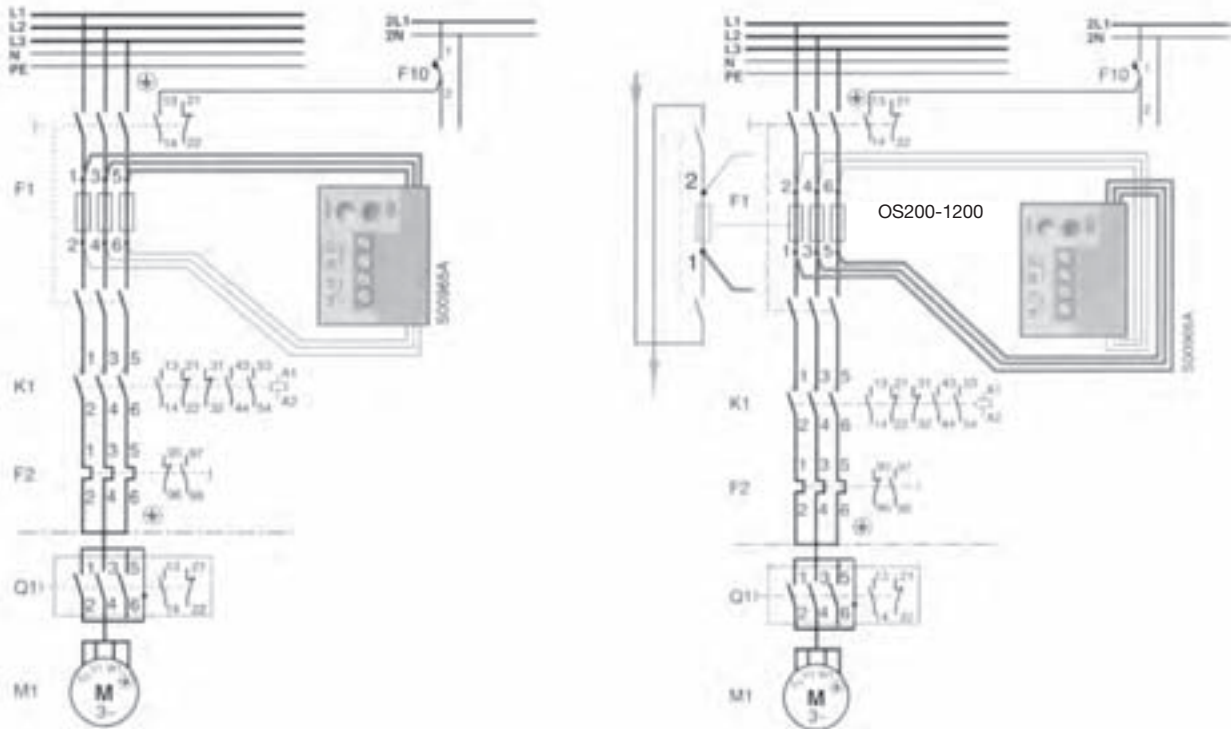
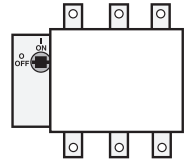

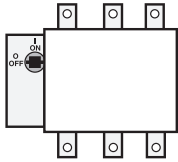

## Approximate dimensions Handles



### Plastic Handles:

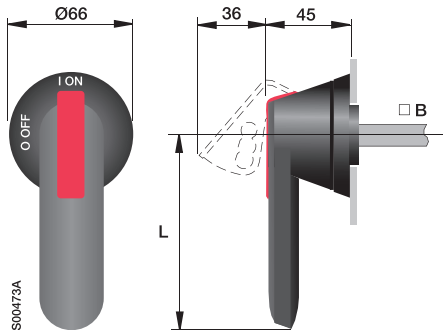

Type	L length mm	B Shaft diameter
OH_45J6	46	6
OH_65J6	65	6
OH_80J6	80	6
OH_125J12	125	12
OH_145J12	145	12
OH_175J12	175	12
OH_275J12	275	12

Door drilling for OH\_handles:

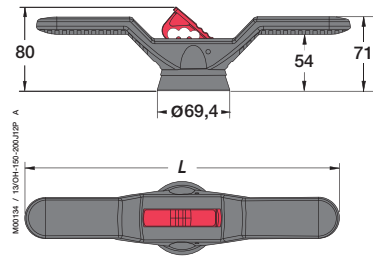
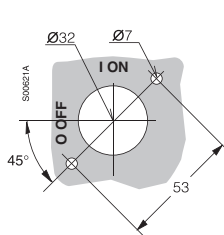

Type	L
OHB150J12P	300
OHB200J12P	400

### Metallic Handles:

YASDA 7,8 (A=220)

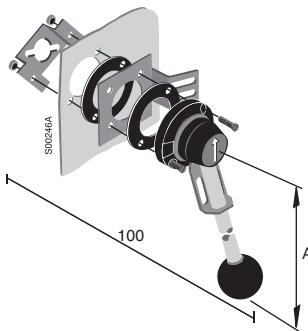

Door drilling for YASDA

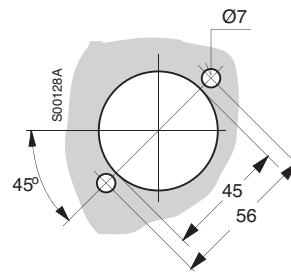

### Stainless steel:

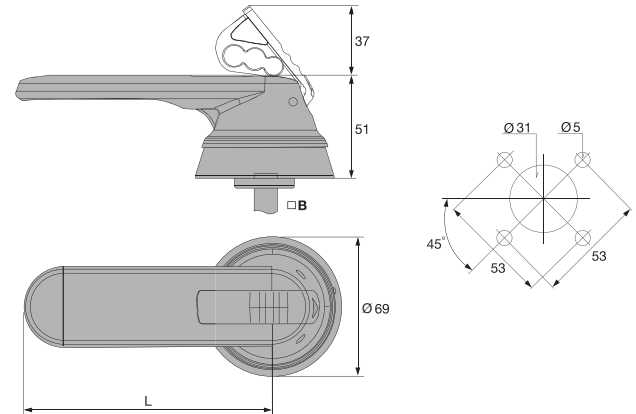

Handle type	OHM65L6	OHM125L12	OHM175L12	OHM275L12
L	65	125	175	275
B	6	12	12	12

### Minimum distance L between the hinge and the rotating shaft

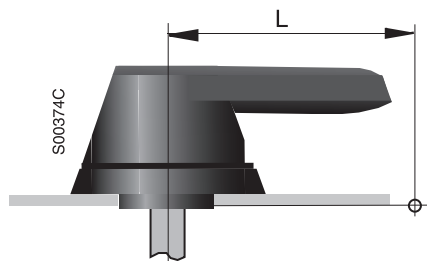

OS Sizes (A)	L (mm)	Suitable handles
30...60	60	OH_45J_, OH_65J_
60...100	80	OH_80J_
200...400	150	OH_125J12, OH_145J12
200...800	175	OH_175J12
200...800	275	OH_275J12
200...800	220	YASDA 7,8
1200	150	OHB150J12P



# Approximate dimensions For Fuses

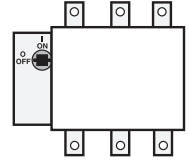

## Class J (600V)

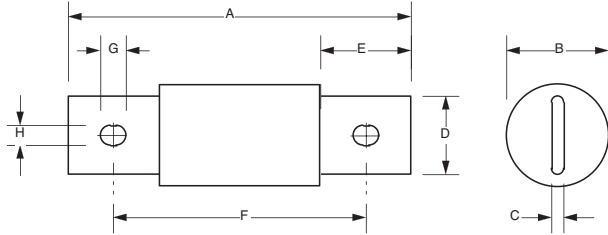

Ampere rating	A	B	C	D	E	F	G	H
1 - 30	2.25	.81	—	—	—	—	—	—
31 - 60	2.38	1.06	—	—	—	—	—	—
61 - 100	4.62	1.12	.12	.75	1	3.62	.38	.28
101 - 200	5.75	1.62	.19	1.12	1.38	4.38	.38	.28
201 - 400	7.12	2.12	.25	1.62	1.88	5.25	.53	.41
401 - 600	8.00	2.5	.38	2.00	2.12	6.00	.69	.53

## Class L (600V)

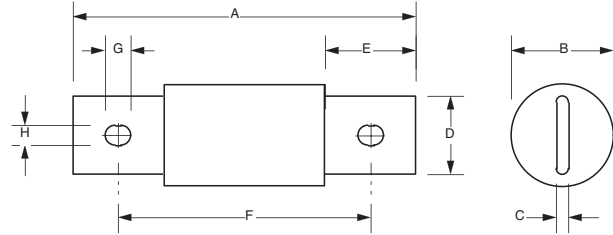

Ampere rating	A	B	C	D	E	F	G	H
200 - 600	8.62	2.00	.31	1.62	2.41	6.25	1.12	.62
601 - 800	8.62	2.50	.38	2.00	2.41	6.25	1.12	.62

## Class T (300V)

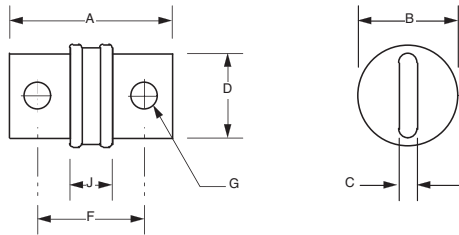

Ampere rating	A	B	C	D	F	G	J
1 - 30	.88	.41	—	—	—	—	—
31 - 60	.88	.56	—	—	—	—	—
61 - 100	2.16	.81	.12	.75	1	3.62	.38
101 - 200	2.45	1.06	.19	1.12	1.38	4.38	.38
201 - 400	2.75	1.33	.25	1.62	1.88	5.25	.53
401 - 600	3.06	1.62	.31	2.00	2.12	6.00	.69
601 - 800	3.38	2.08	.38	1.75	2.22	.55	.88

## Class T (600V)

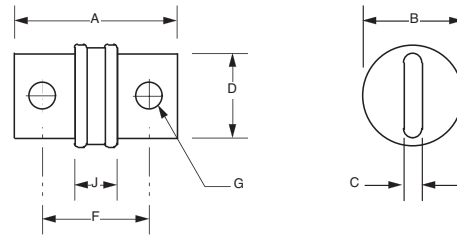

Ampere rating	A	B	C	D	F	G	J
1 - 30	1.50	.56	—	—	—	—	—
35 - 60	1.56	.81	—	—	—	—	—
70 - 100	2.95	—	.12	.75	2.36	.28	1.64
110 - 200	3.25	—	.19	.88	2.50	.34	1.66
225 - 400	3.62	—	.25	1.00	2.69	.41	1.64
450 - 600	3.98	—	.31	1.25	2.95	.48	1.78
601 - 800	4.37	—	.38	1.75	3.17	.55	1.88

## Class CC (600V) — Rejection type

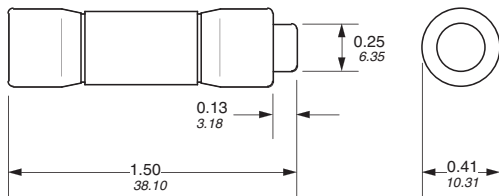

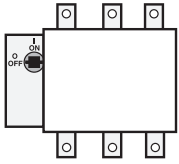

## Approximate dimensions For Terminal lugs



### OZXA-24 — for use with 100A switches

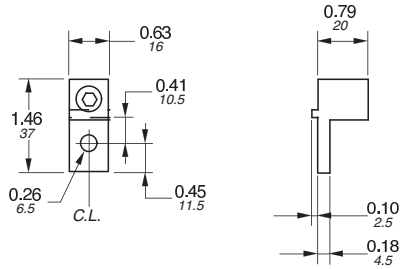

### OZXA-400 — for use with 400A switches

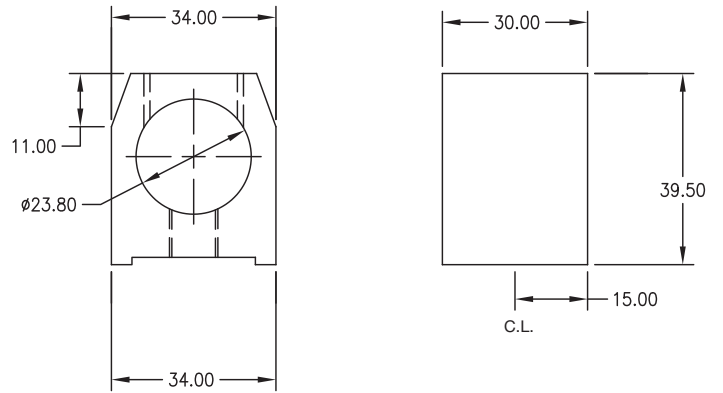

### OZXA-200 — for use with 200A switches

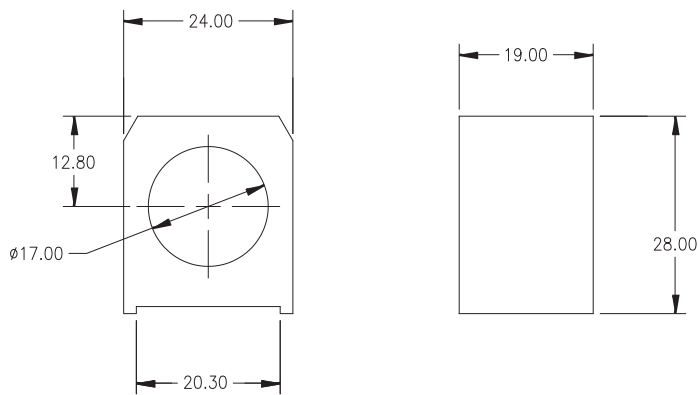

### OZXA-800 — for use with 800A switches

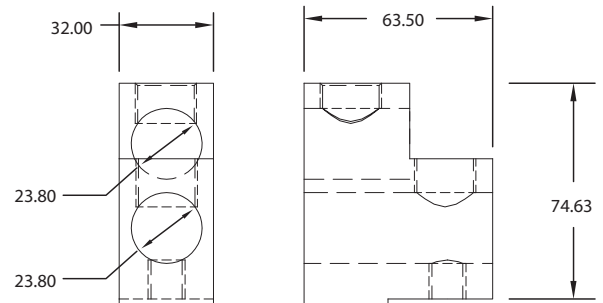

### OZXA-33 — for use with 400A switches

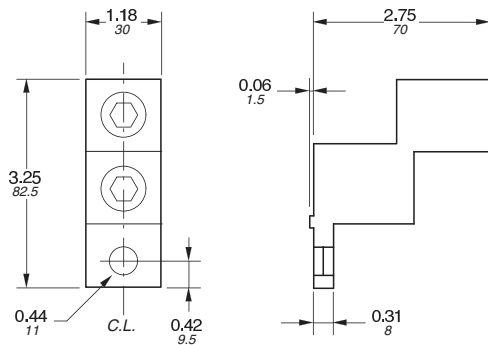







## SafeLine

Compact, heavy duty

Enclosed disconnect switches

16A – 1200A Non-fusible

30A – 1200A Fusible

SafeLine enclosed disconnect switches are designed to meet customer requirements in terms of safety, ease of installation, space savings and operational convenience. They are available in a wide range of ampere ratings, are CSA approved and EEMAC rated to satisfy rugged industrial environments.

### Index

General information .....	3.1 – 3.3
Non-fusible .....	3.4 – 3.7
Fusible.....	3.8 – 3.10
Technical information & dimensions.....	3.11 – 3.12

**NF 16 1 - 3P 11**

#### Disconnect switch type

NF = Non-fusible  
 FJ = Fused Class J, (30A – 600A)  
 FL = Fused Class L, (800A)

#### Disconnect switch frame size

16	32	45	63
30	60	100	200
400	600	800	1200

#### Environmental rating

1 = Type 1  
 2 = Type 12  
 4 = Type 4  
 3 = Type 3R  
 X = Type 4X stainless steel

#### Accessories

10 = 1 N.O. auxiliary contact  
 01 = 1 N.C. auxiliary contact  
 11 = 1 N.O. & 1 N.C. auxiliary contacts  
 22 = 2 N.O. & 2 N.C. auxiliary contacts  
 N = Neutral terminal

#### Poles or conversion mechanisms

2P = 2 poles pistol handle  
 3P = 3 poles pistol handle  
 4P = 4 poles pistol handle  
 6P = 6 poles pistol handle  
 3S = 3 pole selector handle  
 3T = 3 pole transfer, side by side  
 3C = 3 pole transfer, double stack



### Padlockable

Handles can be padlocked in the “OFF” position with up to three padlocks: Additionally, the switch mechanism can be directly padlocked in the “OFF” position when the door is open. NOTE: Some handles can be ordered with the ability to padlock in both the “ON” & “OFF” positions, please consult your ABB sales office.

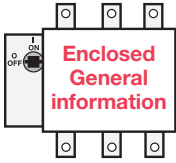

## EEMAC environmental ratings for enclosed disconnect switches

### Introduction

An enclosure is a surrounding case constructed to provide a degree of protection to personnel against accidental contact with the enclosed equipment and to provide a degree of protection to the enclosed equipment against specified environmental conditions.

A brief description of the more common types of enclosures used by the electrical industry relating to their environmental capabilities follows.

Refer to EEMAC Standards Publication for more information regarding applications, features and design tests.

Individual EEMAC product Standards Publications or third party certification standards may contain additional requirements for product testing and performance.

### Definitions pertaining to nonhazardous locations



Type 1

Enclosures are intended for indoor use primarily to provide a degree of protection against limited amounts of falling dirt.



Type 4X

Enclosures are intended for indoor or outdoor use primarily to provide a degree of protection against corrosion, windblown dust and rain, splashing water, hose-directed water and damage from external ice formation.



Type 3R

Enclosures are intended for outdoor use primarily to provide a degree of protection against rain, sleet and damage from external ice formation.



Type 12

Enclosures are intended for indoor use primarily to provide a degree of protection against circulating dust, falling dirt, and dripping non-corrosive liquids.

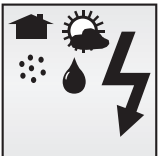

Type 4

Enclosures are intended for indoor or outdoor use primarily to provide a degree of protection against windblown dust and rain, splashing water, hose-directed water and damage from external ice formation.



Type 13

Enclosures are intended for indoor use primarily to provide a degree of protection against dust, spraying of water, oil and noncorrosive coolant.

### Legend

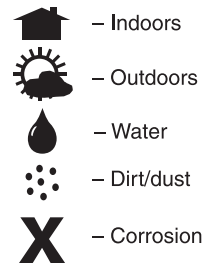

# IP environmental ratings for enclosed disconnect switches

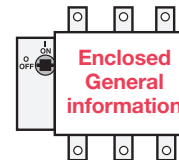

## IP ratings

indicate the degree of protection against dust, liquids and impacts. The IP degrees of protection are defined by the French standard NFC 20-010. To rate a device's degrees of protection, the letters IP are followed by up to three numbers. These numbers are defined as follows:

first number protection against solid objects	second number protection against liquids	third number protection against mechanical impacts
<p><b>IP 0</b>  no protection</p>	<p><b>IP 0</b>  no protection</p>	<p><b>IP 0</b>  no protection</p>
<p><b>1</b>  protected against solid objects over 50mm (e.g. accidental touch by hands.)</p>	<p><b>1</b>  protected against vertically falling rain or condensation</p>	<p><b>1</b>  impact 0.225 joule 150g falling from 15 cm</p>
<p><b>2</b>  protected against solid objects over 12 mm (e.g. fingers)</p>	<p><b>2</b>  protected against direct sprays of water up to 15° from vertical</p>	<p><b>2</b>  impact 0.375 joule 250g falling from 15 cm</p>
<p><b>3</b>  protected against solid objects over 2.5 mm (tools &amp; wires)</p>	<p><b>3</b>  protected against sprays to 60° from vertical</p>	<p><b>3</b>  impact 0.50 joule 250g falling from 20cm</p>
<p><b>4</b>  protected against solid objects over 1mm (small tools &amp; small wires)</p>	<p><b>4</b>  protected against water sprayed from all directions</p>	<p><b>5</b>  impact 2.00 joule 500g falling from 40 cm</p>
<p><b>5</b>  protected against dust (no harmful deposit)</p>	<p><b>5</b>  protected against low pressure jets of water from all directions</p>	<p><b>7</b>  impact 6.00 joule 1.5kg falling from 40 cm</p>
<p><b>6</b>  totally protected against dust</p>	<p><b>6</b>  protected from strong jets of water (e.g. for use on ship decks)</p>	<p><b>9</b>  impact 20.00 joule 5 kg falling from 40 cm</p>
	<p><b>7</b>  protected against the effects of immersion between 15cm and 1m</p>	

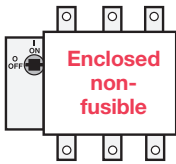

## Enclosed manual motor controllers 16A – 80A



NF321-3P



EOT16U3P3-S



EOT16U4P3-P

### 3 Pole, 600V, 16A – 80A — CSA C22.2 No. 14 enclosed manual motor controllers

Metal Enclosure type

CSA C22.2 No. 14 amp rating	HP		1		12		4		4X Stainless	
	480V	600V	Catalog number	List price	Catalog number	List price	Catalog number	List price	Catalog number	List price
	16	10	NF161-3S		NF162-3S		—		—	
	16	10	NF161-3P		NF162-3P		NF164-3P		NF16X-3P	
	40	20	NF321-3S		NF322-3S		—		—	
	40	20	NF321-3P		NF322-3P		NF324-3P		NF32X-3P	
	60	30	NF451-3S		NF452-3S		—		—	
	60	30	NF451-3P		NF452-3P		NF454-3P		NF45X-3P	
	80	40	NF631-3S		NF632-3S		—		—	
	80	40	NF631-3P		NF632-3P		NF634-3P		NF63X-3P	

Plastic Enclosure type

CSA C22.2 No. 14 amp rating	HP		3R, 12				4, 4X, 12			
	480V	600V	Catalog number	Aux. contact	Handle Type	List price	Catalog number	Aux. contact	Handle Type	List price
	16	10	EOT16U3P3-1S	1NO	Selector		EOT16U3P4-1P	1NO	Pistol	
	16	10	EOT16U3P3-S	—	Selector		EOT16U3P4-P	—	Pistol	
	40	20	EOT32U3P3-1S	1NO	Selector		EOT32U3P4-1P	1NO	Pistol	
	40	20	EOT32U3P3-S	—	Selector		EOT32U3P4-P	—	Pistol	
	60	30	EOT45U3P3-1S	1NO	Selector		EOT45U3P4-1P	1NO	Pistol	
	60	30	EOT45U3P3-S	—	Selector		EOT45U3P4-P	—	Pistol	
	80	40	—	—	—		EOT63U3P4-1P	1NO	Pistol	
	80	40	—	—	—		EOT63U3P4-P	—	Pistol	

### Accessories for eOT16 to eOT63

**Auxiliary contacts** \*Maximum number of auxiliary contacts 2NO + 1NC

AC rated voltage	Description	AC amp rating	Catalog number	List price
600	NO, mounts on right side of the switch only	10	OA1G10	
600	NC, mounts on left side of the switch only	10	OA1G01	
4th poles for eOT16 and eOT32 * Only one additional pole per switch	4th pole	40	OTPS40FPN*	
600	4th pole, late-break / early-make function	40	OTPL40FP	
4th poles for eOT45 * and eOT63* Only one additional pole per switch	4th pole	80	OTPS80FP	
600	4th pole, late-break / early-make function	80	OTPL80FP	

\*N1 = On the left side of the switch N2 = On the right side of the switch

**NOTE:** All enclosed switches are provided with a black handle; however, most handles can be substituted with a red and yellow handle by adding the "Y" suffix to the end of the catalog number. There is no additional price adder for changing to a red/yellow handle of equal ratings and style.

**EXAMPLE:** A red/yellow selector handle for an NF161-3S can be substituted for the black selector handle by using the "Y" suffix at the end, new catalog NF161-3SY.

## Enclosed non-fusible disconnect switches 16A – 1200A

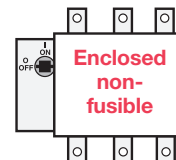

NF301-3P



NF1001-3P



NF2001-3P

### 3 Pole, 600V, 30A – 2000A — CSA C22.2 No. 4 enclosed switches

Metal Enclosure type

CSA C22.2 No. 4 amp rating	HP		1		12		4		4X Stainless	
	480V	600V	Catalog number	List price	Catalog number	List price	Catalog number	List price	Catalog number	List price
30	20	30	NF301-3P		NF302-3P		NF304-3P		NF30X-3P	
60	40	40	NF601-3P		NF602-3P		NF604-3P		NF60X-3P	
100	50	50	NF1001-3P		NF1002-3P		NF1004-3P		NF100X-3P	
200	150	200	NF2001-3P		NF2002-3P		NF2004-3P		NF200X-3P	
400	250	350	NF4001-3P		NF4002-3P		NF4004-3P		NF400X-3P	
600	400	500	NF6001-3P		NF6002-3P		NF6004-3P		NF600X-3P	
800	500	500	NF8001-3P		NF8002-3P		NF8004-3P		NF800X-3P	
1200	-	-	NF12001-3P		NF12002-3P		NF12004-3P		NF1200X-3P	



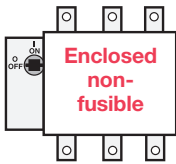

## Enclosed non-fusible disconnect switches

### 30 - 1200A

### Other configurations

CSA General purpose amp rating	Option (Descriptions found on page 3.17)	Enclosure type							
		1		12		4		4XStainless	
		Catalog number	List price	Catalog number	List price	Catalog number	List price	Catalog number	List price
30	4 pole switch	NF301-4P		NF302-4P		NF304-4P		NF30X-4P	
	6 pole switch	NF301-6P		NF302-6P		NF304-6P		NF30X-6P	
	Transfer switch	NF301-3T		NF302-3T		NF304-3T		NF30X-3T	
60	4 pole switch	NF601-4P		NF602-4P		NF604-4P		NF60X-4P	
	6 pole switch	NF601-6P		NF602-6P		NF604-6P		NF60X-6P	
	Transfer switch	NF601-3T		NF602-3T		NF604-3T		NF60X-3T	
100	4 pole switch	NF1001-4P		NF1002-4P		NF1004-4P		NF100X-4P	
	6 pole switch	NF1001-6P		NF1002-6P		NF1004-6P		NF100X-6P	
	Transfer switch	NF1001-3T		NF1002-3T		NF1004-3T		NF100X-3T	
200	2 pole switch	NF2001-2P		NF2002-2P		NF2004-2P		NF200X-2P	
	4 pole switch	NF2001-4P		NF2002-4P		NF2004-4P		NF200X-4P	
	6 pole switch	NF2001-6P		NF2002-6P		NF2004-6P		NF200X-6P	
	Transfer switch	NF2001-3T		NF2002-3T		NF2004-3T		NF200X-3T	
400	2 pole switch	NF4001-2P		NF4002-2P		NF4004-2P		NF400X-2P	
	4 pole switch	NF4001-4P		NF4002-4P		NF4004-4P		NF400X-4P	
	6 pole switch	NF4001-6P		NF4002-6P		NF4004-6P		NF400X-6P	
	Transfer switch	NF4001-3T		NF4002-3T		NF4004-3T		NF400X-3T	
600	2 pole switch	NF6001-2P		NF6002-2P		NF6004-2P		NF600X-2P	
	4 pole switch	NF6001-4P		NF6002-4P		NF6004-4P		NF600X-4P	
	6 pole switch	NF6001-6P		NF6002-6P		NF6004-6P		NF600X-6P	
	Transfer switch	NF6001-3T		NF6002-3T		NF6004-3T		NF600X-3T	
800	2 pole switch	NF8001-2P		NF8002-2P		NF8004-2P		NF800X-2P	
	4 pole switch	NF8001-4P		NF8002-4P		NF8004-4P		NF800X-4P	
	6 pole switch	NF8001-6P		NF8002-6P		NF8004-6P		NF800X-6P	
	Transfer switch	NF8001-3T		NF8002-3T		NF8004-3T		NF800X-3T	
1200	2 pole switch	NF12001-2P		NF12002-2P		NF12004-2P		NF1200X-2P	
	4 pole switch	NF12001-4P		NF12002-4P		NF12004-4P		NF1200X-4P	
	6 pole switch	NF12001-6P		NF12002-6P		NF12004-6P		NF1200X-6P	
	Transfer switch	NF12001-3T		NF12002-3T		NF12004-3T		NF1200X-3T	

① Please consult ABB sales office for additional information.

②  $\text{⏏}$  = Three poles

# Accessories for enclosed non-fusible disconnect switches

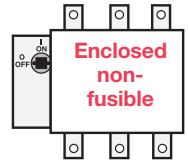

## Auxiliary contacts

For use on:	Contact configuration	Installation suffix	Installed list price adder
16A – 100A	1 N.O.	add "10" suffix	
	1 N.C.	add "01" suffix	
	1 N.O. & 1 N.C.	add "11" suffix	
200A – 1200A	1 N.O. & 1 N.C.	add "11" suffix	
	2 N.O. & 2 N.C.	add "22" suffix	

## Accessories<sup>①②</sup>

For use on:	Description	Installation suffix	Installed list price adder
30A – 100A	Neutral block	N	
200 A	Neutral block	N	
400 A	Neutral block	N	
600 A	Neutral block	N	
800 A	Neutral block	N	
1200A	Neutral block	N	

## Ground lugs

All enclosed switches are provided with a standard integral ground lug.

Switch size	Ground lug Wire size
16A – 100A	(2) #14
200A – 400A	#6 – 250 mcm
600A – 1200A	#2 – 600 mcm

## Switch ratings, 16 – 1200 Amps, 600V

CSA General purpose amp rating	Maximum horsepower rating						Wire size for terminal lugs	For wire type	Approval
	Single phase		Three phase						
	120V	240V	200V – 208V	240V	480V	600V			
16	1	2	3	5	10	10	#18 – #8	Cu	CSA ①
40	2	5	10	10	20	25	#18 – #8	Cu	CSA ①
60	2	5	15	15	30	30	#14 – #1	Cu	CSA ①
80	2	5	20	20	40	40	#14 – #1	Cu	CSA ①
30	2	5	10	10	20	30	#14 – #4	Cu	CSA ②
60	3	7.5	20	20	40	40	#14 – #4	Cu	CSA ②
100	5	15	25	30	50	50	#8 – 1/0	Cu	CSA ②
200	—	—	60	75	150	200	#6 – 300 kcmil	Cu/Al	CSA ②
400	—	—	100	125	250	350	#2 – 600 kcmil	Cu/Al	CSA ②
600	—	—	150	200	400	500	(2) #2 – 600 kcmil	Cu/Al	CSA ②
800	—	—	200	250	500	500	(2) #2 – 600 kcmil	Cu/Al	CSA ②
1200	—	—	—	—	—	—	(4) #2 – 600 kcmil	Cu/Al	CSA ②

① CSA C22.2 No. 14

② CSA C22.2 No. 4



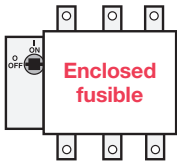

## Enclosed fusible disconnect switches 30A – 1200A

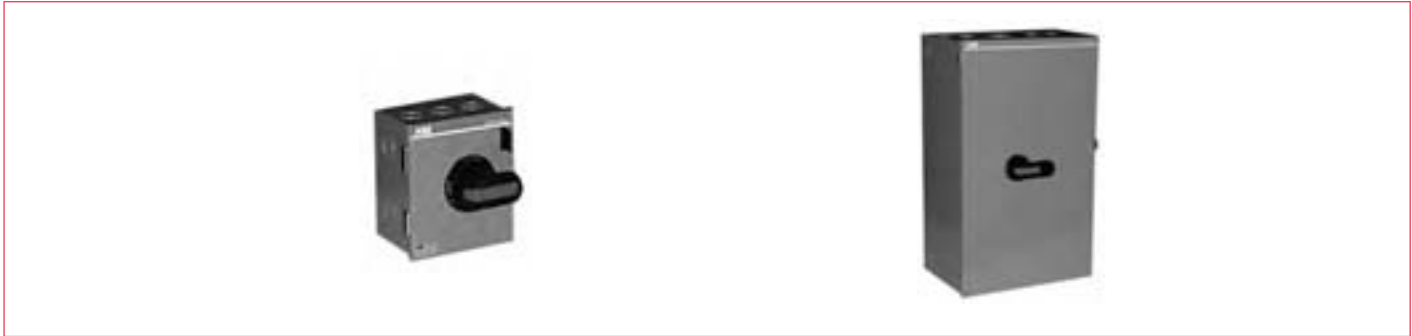

### 3 Pole<sup>①</sup>, 600V, 30A - 1200A

CSA general purpose amp rating	Fuse type	Enclosure type								
		1		12		4		4X Stainless		
		Catalog number	List price	Catalog number	List price	Catalog number	List price	Catalog number	List price	
	30	J	FJ301-3P		FJ302-3P		FJ304-3P		FJ30X-3P	
	60	J	FJ601-3P		FJ602-3P		FJ604-3P		FJ60X-3P	
	100	J	FJ1001-3P		FJ1002-3P		FJ1004-3P		FJ100X-3P	
	200	J	FJ2001-3P		FJ2002-3P		FJ2004-3P		FJ200X-3P	
	400	J	FJ4001-3P		FJ4002-3P		FJ4004-3P		FJ400X-3P	
	600	J	FJ6001-3P		FJ6002-3P		FJ6004-3P		FJ600X-3P	
	800	L	FL8001-3P		FL8002-3P		FL8004-3P		FL800X-3P	
	1200	L	FL12001-3P		FL12002-3P		FL12004-3P		FL1200X-3P	

NOTE: All enclosed switches are provided with a black handle; however, most handles can be substituted with a red and yellow handle if desired. Please add the "Y" handle suffix code at the end of catalog number. There is no additional price adder for changing to a red/yellow handle of equal ratings and style.

EXAMPLE: A red/yellow pistol handle for an FJ301-3P can be substituted for the black pistol handle by adding the "Y" suffix at the end, new catalog number: FJ301-3PY.

### Switch ratings

CSA general purpose amp rating	Maximum horsepower rating								Wire size for terminal lugs	For wire type	Approval <sup>①</sup>
	Single phase			Three phase							
	120V	200V	240V	200V	208V	240V	480V	600V			
30	2	3	5	5	7.5	7.5	15	20	#18 – #8	Cu	CSA
60	3	7.5	10	15	15	15	30	50	#14 – #4	Cu	CSA
100	5	10	15	25	25	30	60	75	#14 – 2/0	Cu/Al	CSA
200	—	—	—	50	50	60	125	150	#6 – 300 kcmil	Cu/Al	CSA
400	—	—	—	100	125	125	250	350	#2 – 600 kcmil	Cu/Al	CSA
600	—	—	—	150	150	200	400	500	(2) #2 – 600 kcmil	Cu/Al	CSA
800	—	—	—	200	200	250	500	500	(2) #2 – 600 kcmil	Cu/Al	CSA
1200	—	—	—	—	—	—	—	—	(4) #2 – 600 kcmil	Cu/Al	CSA

<sup>①</sup> Fusible switches are CSA approved to the CSA C22.2 No. 4 standard.

# Enclosed fusible disconnect switches

## 30A – 1200A

### Other configurations

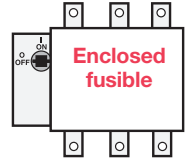

CSA general purpose amp rating	Option	Enclosure type							
		1		12		4		4X Stainless	
		Catalog number	List price	Catalog number	List price	Catalog number	List price	Catalog number	List price
30	4 pole switch	FJ301-4P		FJ302-4P		FJ304-4P		FJ30X-4P	
	6 pole switch	FJ301-6P		FJ302-6P		FJ304-6P		FJ30X-6P	
60	4 pole switch	FJ601-4P		FJ602-4P		FJ604-4P		FJ60X-4P	
	6 pole switch	FJ601-6P		FJ602-6P		FJ604-6P		FJ60X-6P	
100	2 pole switch	FJ1001-2P		FJ1002-2P		FJ1004-2P		FJ100X-2P	
	4 pole switch	FJ1001-4P		FJ1002-4P		FJ1004-4P		FJ100X-4P	
	6 pole switch	FJ1001-6P		FJ1002-6P		FJ1004-6P		FJ100X-6P	
200	2 pole switch	FJ2001-2P		FJ2002-2P		FJ2004-2P		FJ200X-2P	
	4 pole switch	FJ2001-4P		FJ2002-4P		FJ2004-4P		FJ200X-4P	
	6 pole switch	FJ2001-6P		FJ2002-6P		FJ2004-6P		FJ200X-6P	
400	2 pole switch	FJ4001-2P		FJ4002-2P		FJ4004-2P		FJ400X-2P	
	4 pole switch	FJ4001-4P		FJ4002-4P		FJ4004-4P		FJ400X-4P	
	6 pole switch	FJ4001-6P		FJ4002-6P		FJ4004-6P		FJ400X-6P	
600	2 pole switch	FJ6001-2P		FJ6002-2P		FJ6004-2P		FJ600X-2P	
	4 pole switch	FJ6001-4P		FJ6002-4P		FJ6004-4P		FJ600X-4P	
	6 pole switch	FJ6001-6P		FJ6002-6P		FJ6004-6P		FJ600X-6P	
800	2 pole switch	FL8001-2P		FL8002-2P		FL8004-2P		FJ800X-2P	
	4 pole switch	FL8001-4P		FL8002-4P		FL8004-4P		FJ800X-4P	
	6 pole switch	FL8001-6P		FL8002-6P		FL8004-6P		FJ800X-6P	
1200	2 pole switch	FL12001-2P		FL12002-2P		FL12004-2P		FL1200X-2P	
	4 pole switch	FL12001-4P		FL12002-4P		FL12004-4P		FL1200X-4P	

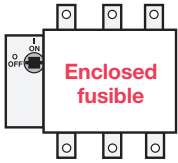

## Accessories

### Enclosed fusible disconnect switches

#### Auxiliary contacts

For use on:	Contact configuration	Installation suffix	Installed list price adder
30A	1 N.O. + 1 N. C.	add "11" suffix	
	2 N.O. + 2 N.C.	add "22" suffix	
60A – 100A	1 N.O. + 1 N.C.	add "11" suffix	
	2 N.O. + 2 N.C.	add "22" suffix	
200A – 1200A	1 N.O. & 1 N.C.	add "11" suffix	
	2 N.O. & 2 N.C.	add "22" suffix	

#### Accessories

For use on:	Description	Installation suffix	Installed list price adder
30A – 100A	Neutral block	N	
200A	Neutral block	N	
400A	Neutral block	N	
600A	Neutral block	N	
800A	Neutral block	N	
1200A	Neutral block	N	

#### Ground lugs

All enclosed switches are provided with a standard integral ground lug.

Switch size	Ground lug wire size
30 – 100	(2) # 14 – 4
200	#14 – 2/0
400 – 800	#6 – 300 mcm
1200	#2 – 600 mcm

# Other configuration descriptions

## Enclosed disconnect switches

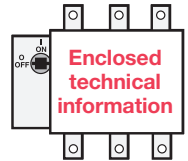

### Conversion mechanisms

#### 6 pole

6 pole mechanism allows two switches controlled by one handle to open or close simultaneously.

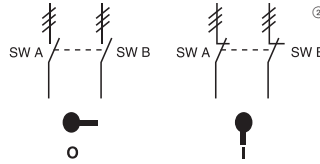

	POS. O	POS. I
SW. A	O	X
SW. B	O	X

X = Closed  
O = Open

#### Transfer<sup>①</sup>

Transfer mechanism manually transfers between two power sources using two switches and a center "OFF" position.

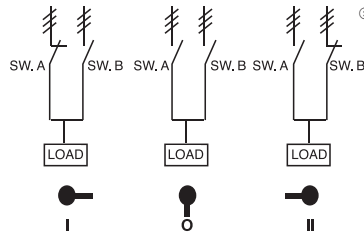

	POS. I	POS. O	POS. II
SW. A	X	O	O
SW. B	O	O	X

X = Closed  
O = Open

<sup>①</sup> Transfer and bypass enclosed switches include the load side bussed or cabled together, and all switches come standard with ground lugs.

<sup>②</sup> = Three poles

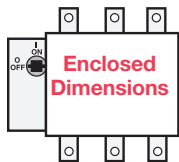

# Safe Line Dimensions<sup>①②</sup> 600V 16-1200A Amps

## Dimensions for metal and stainless steel enclosures Type 1, 12, 4 and 4X

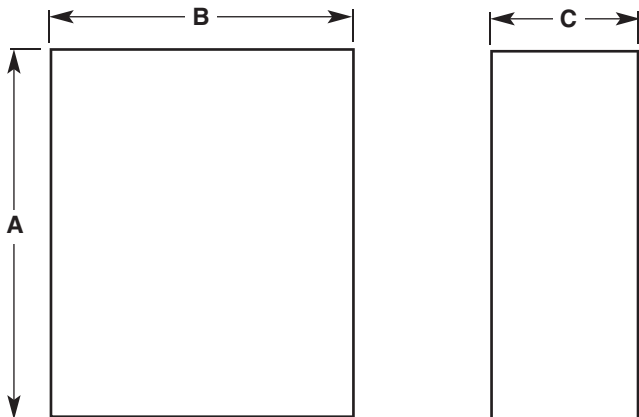

## Non-fusible switches

	A Height	B Width	C Depth
NF16, NF32,	6	5	4
NF30, NF45, NF60, NF63	10	5	4
NF100	16	6	4
NF200	24	14	8
NF400	36	24	10
NF600	36	24	10
NF800	48	24	12
NF1200	48	24	12

## Fusible switches

	A Height	B Width	C Depth
F30	10	8	6
F60	10	8	6
F100	16	10	6
F200	24	14	8
F400	36	24	10
F600	36	24	10
F800	48	24	12

## Dimensions for eOT

### eOT16\_S, eOT32\_S (enclosure size 1)

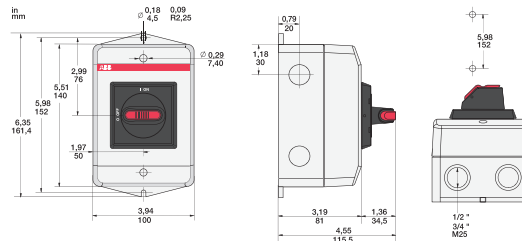

### eOT16\_P, eOT32\_P (enclosure size 1)

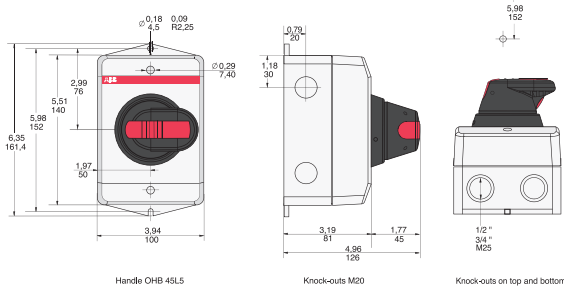

### eOT45U\_S (enclosure size 2)

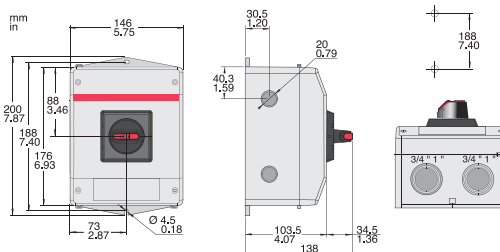

### eOT45U\_P (enclosure size 2)

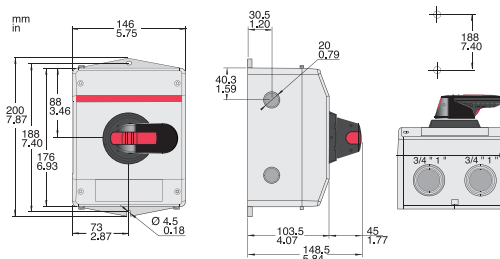

### eOT63U\_P

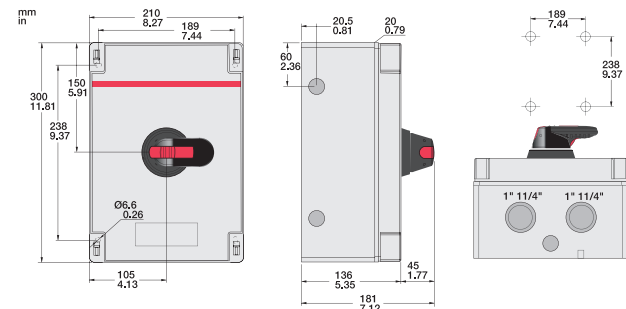



# CamLine Rotary cam switches OM, ON and OL

## Contents:

### Rotary cam switches

Standard cam switches range .....	4.6 - 4.7
Accessories for standard cam switches .....	4.8 - 4.9
Special cam switches .....	4.10 - 4.11
Solutions .....	4.12 - 4.15
Technical data.....	4.16 - 4.17
Ordering details	
ON-OFF switches.....	4.18 - 4.19
Change-over switches.....	4.20 - 4.22
Bypass switches .....	4.23
Multistep switches.....	4.24 - 4.27
Motor control switches.....	4.28 - 4.29
Ventilation switches .....	4.28
Reversing switches .....	4.28
Star-delta switches .....	4.28
2 speed switches .....	4.28
Pumpstart switches .....	4.29
Stop switches.....	4.29
Start switches.....	4.29
Voltmeter switches .....	4.30
Ammeter switches .....	4.31
Volt-ammeter switches.....	4.31
Binary code switches .....	4.32
Accessories .....	4.33 - 4.35
Dimension drawings.....	4.36 - 4.53
OM, ON, door mounted .....	4.36
ON_M, ON, base mounted .....	4.37
OL40 .....	4.37 - 4.39
Door mounted .....	4.37 - 4.38
Base mounted.....	4.39
OL80, OL125, OL160.....	4.40 - 4.41
Door mounted .....	4.40
Base mounted .....	4.41
OL200 .....	4.42
Door mounted .....	4.42
Base mounted .....	4.42
Front plates .....	4.43
Handles .....	4.44
For OM.....	4.44
For ON and OL40 .....	4.45 - 4.46
Padlockable handles.....	4.45 - 4.48
Key interlocked handles .....	4.49
Push button interlocked handle .....	4.50
Pistol and double lever handles .....	4.50
Door clutch.....	4.51
Double gang drive.....	4.52
Triple gang drive .....	4.53
<b>Enclosed rotary cam and main switches</b>	
Ordering details .....	4.56 - 4.57
Dimension drawings.....	4.58

# ROTARY CAM SWITCHES

Range OM, ON, OL  
Sizes 10, 25, 40, 80, 125, 160 and 200 Amps

ABB's new OM, ON and OL rotary cam switches offer a complete range of cam switches for control, instrumentation and motor starting applications, maximizing the benefits and optimizing your use of assets. The standard cam switches provide you with a variety of functionalities for the most common mounting types and applications with minimum footprint area.

## A focused standard range covering most applications

ON-OFF switches  
Change-over switches  
Multi-step switches

Volt-ammeter switches  
Ammeter switches  
Voltmeter switches

Bypass switches  
Closed transition switches  
UPS switches

Reversing switches  
Pump-start switches  
Stop-start switches  
Ventilation switches

Binarycode switches

### Standards

IEC/EN 60 947-1, -3  
VDE 0660 Teil 107  
UL508  
CSA C22.2 No.14

► Captive plus-minus screws save installation time and the integrated screwdriver guides make the use of motorized screwdrivers easy and stable.



## Quick and easy to install

Captive plus-minus screws save installation time and the integrated screwdriver guides (available in sizes up to 160 Amps) make the use of motorized screwdrivers easy and stable. Lug terminals for connecting cable clamps and crimp lugs are available for the sizes from 125 Amps.

The double cam system shortens the multistep switch and enables the use of shallow enclosures. The sizes up to 40 Amps, including a black handle on a silver front plate, are suitable for snap on door mounting while the sizes from 80 to 200 Amps contain screw-mounted handles for door mounting.

► Self lifting terminal screws for fast cabling



◀ Complete delivery includes handle and front plate. Snap-on mounting of contact block with interlocking in sizes OM, ON and OL 40. Protected interconnections.

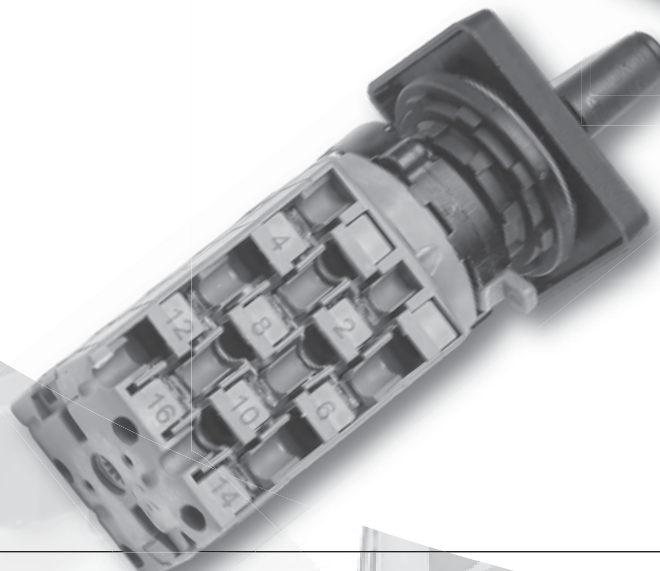

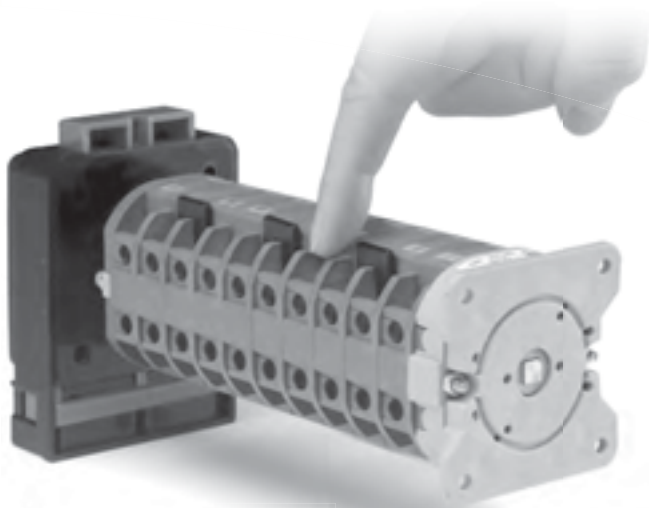

▲ Finger-proof tunnel terminals eliminate the risk of touching live parts without adding any protective covers.

◀ Versatile selection of padlocking and interlocking solutions

## Safe to use with reliable contacts

Finger-proof tunnel terminals and interconnections eliminate the risk of touching live parts without adding any protective covers. This ensures safe operation, protecting people and equipment. The switches provide reliable isolation and stable contact positions with or without overlapping contacts.

The switches are designed for resistive and slightly inductive motor loads having a high switching reliability in distinctive environments, providing you with added value. Breaking capacity tests performed, cover CSA C22.2 No.14 Manual Motor Controller.

The well-enclosed contact chamber construction and special design of the OM's contact tip with high contact pressure ensure increased contact reliability and a long life span. Due to the contact design, the switches are also suitable for very low voltages (5 V) and currents (5mA). Gold-plated contacts are available on request.

## Special cam switches for distinctive requirements

Special cam switches can be configured on the Internet by the Camweb configurator. The specification and ordering of special cam switches is as easy as selecting standard products!

## What can be specified by Camweb?

Distinctive needs, such as front plate engraving, padlocking in various positions, key operation, key interlocking, auxiliary contacts for low ratings and special timings can be specified with the configuration tool. It is also possible to build switches with different chamber sizes in the same switch. Double and triple gang switches, as well as long cam switches with metallic shaft, can be specified with up to 60 contacts and 12 positions.

### Easy to specify and to order

The user-friendly Camweb configuration tool is very simple to use: it provides a new approach to ordering with easy specifications and a minimized total delivery time. The tool guides the user in order to avoid incompatible/impossible solutions, eliminating mistakes and automatically generating the type and the ordering code. The optional paste and order tool generates the price for immediate ordering. The order handling of the special cam switch is as smooth as for the standard products - the same information goes transparent and unchanged throughout the process.

The Camweb configuration tool can be found on the ABB Internet site or directly from the address:  
[a.salesconfigurator.com](http://a.salesconfigurator.com)





# Standard CAM SWITCHES RANGE

Black handle and silver frontplate with standard text are included.

Cam  
Line  
CSM

		Cam switch size
		I <sub>th</sub> / IEC 60947 [A]
		CSA C22.2 No.14 [A]
		Positions
<b>ON-OFF switches</b>		
Rotating angle 90, 0-position: 9 o'clock		
Black handle		1 - 0
Key operated		1 - 0
Rotating angle 90, 0-position: 12 o'clock		
Black handle		1 - 0
Key operated		1 - 0
<b>Change-over switches</b>		
Rotating angle 60 - 0 - 60, with 0-position		
Black handle		1 - 0 - 2
Key operated		1 - 0 - 2
Key operated, with two sided spring return		1 <sub>R</sub> - 0 - 2 <sub>R</sub>
Rotating angle 60 - 60, without 0-position		1 - 2
With common center position and with overlapping contacts		1 - 1+ 2 - 2
<b>Bypass switches</b>		
Without overlapping, for 3 and 4-pole net		1 - 0 - Bypass
With overlapping, for 3 and 4-pole net		1 - Bypass
<b>Multistep switches</b>		
With 0-position		
2 - step switches		0-1-2
3- step switches		0-1-2-3
4- step switches		0-1-2-3-4
5- step switches		0-1-2-3-4-5
6- step switches		0-1-2-3-4-5-6
7, 8, 9, 10 and 11- step switches		0-1-2-3-4-5-6-7-8...-11
Without 0-position		
3- step switches		1-2-3
4- step switches		1-2-3-4
5- step switches		1-2-3-4-5
6- step switches		1-2-3-4-5-6
7, 8, 9, 10, 11 and 12- step switches		1-2-3-4-5-6-7-8...-12
<b>Motor control switches</b>		
Ventilation switches		A - 0 - 1/2 - 1/1
Reversing switches		1 - 0 - 2
Star-delta switches		0 - Y - Δ
Pole-change switches (Dahlander)		0 - A - AYY
Pumpstart switches		0 - 1
Stop switches		0 <sub>R</sub> - Stop
Start switches		Stop - Start
		0 <sub>R</sub> - Start
		0 - 1 <sub>R</sub> - Start
		Start - 1 <sub>R</sub> - 0 - 2 <sub>R</sub> - Start
<b>Volt-ammeter switches</b>		
3 phases and 3 current transformers with common pole		0 - 1 - 2 - 3
<b>Voltmeter switches</b>		
4 positions, 3 phase - 3 wire, with 0-position		0, L1-L2, L2-L3, L3-L1
3 positions, 3 phase - 3 wire, without 0-position		L1-L2, L2-L3, L3-L1
7 positions, 3 phase to phase, 3 phase to neutral, without 0-position		L1-L3, L2-L3, L1-L2, L1-N, L2-N, L3-N
7 positions, 3 phase to phase, 3 phase to neutral, with 0-position		L1-L3, L2-L3, L1-L2, 0, L1-N, L2-N, L3-N
7 positions, 3 phase to phase voltages for 2 circuits, with 0-position		L1-L3, L2-L3, L1-L2, 0, L1-L3, L2-L3, L1-L2
<b>Ammeter switches</b>		
For 3 current transformer circuits, with 0-position		0 - 1 - 2 - 3
<b>Binarycode switches</b>		
		0-1-2-3-4-5-6-7...-9...-11



Door mounted

DIN rail mounted

	OM	ON	OL40	OL80	OL125	OL160	OL200	ON M
	10	25	45	115	150	175	280	25
	10	25	40	80	125	160	200	25
		1, 2, 3, 4, 5 and 6- pole 1 and 3- pole			1, 2, 3 and 4- pole -			1, 2, 3 and 6- pole -
		1, 2, 3, 4, 5 and 6- pole 1 and 3- pole			1, 2, 3 and 4- pole -			1, 2, 3 and 6- pole -
		1, 2, 3 and 4- pole 1 and 3- pole			1, 2, 3 and 4- pole -			1, 2, 3 and 4- pole -
	1 and 3- pole	1, 2 and 3- pole			-			1- pole
		1, 2, 3 and 4- pole			-			1, 2, 3 and 4- pole
	-	3 and 4- pole			3 and 4- pole			-
	-	3 / 6- pole, 4 / 8- pole			3 / 6- pole, 4 / 8- pole			-
	-	4 / 6- pole, 4 / 8- pole			4 / 6- pole, 4 / 8- pole			-
		1, 2, 3 and 4- pole			-			1- pole
		1, 2, 3 and 4- pole	1- pole		-			1- pole
		1, 2 and 3- pole	-		-			-
		1 and 2- pole	-		-			-
	-	1, 2 and 3- pole	-		-			-
	-	1- pole	-		-			-
		1, 2, 3 and 4- pole	-		1-pole			1- pole
		1, 2 and 3- pole	-		-			-
		1 and 2- pole	-		-			-
	-	1, 2 and 3- pole	-		-			-
	-	1- pole	-		-			-
		2- pole	-		-			1- pole
	-	3- pole	-		-			-
	-	3- pole	-		3- pole			-
	-	3- pole	-		3- pole			-
		1- pole	-		-			1- pole
		2- pole	-		-			-
	-	1- pole	-		-			-
		1- pole	-		-			-
		1- pole	-		-			1- pole
	-	1- pole	-		-			1- pole
		3- pole	-		-			-
		3- pole	-		-			3- pole
		3- pole	-		-			3- pole
		3- pole	-		-			3- pole
		4- pole	-		-			-
	1- pole	1 and 2- pole	-		-			1- pole
	-	1 and 2- pole	-		-			-

# ACCESSORIES

for standard cam switches

Camline

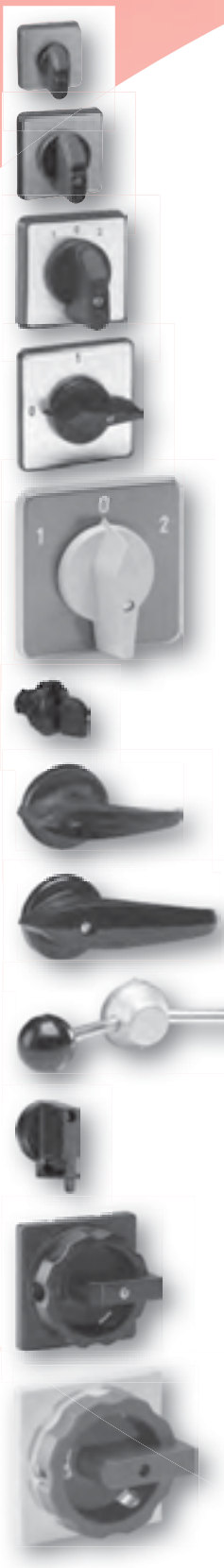

► Handles

## Handles

- Snap on handle with front plate without engraving
  - Size 30x30, black, grey, red, red-yellow
  - Size 48x48, black, grey, red, red-yellow
  - Size 64x64, black, grey, red, red-yellow
- Screw mounting handle with front plate without engraving
  - Size 90x90, black, grey, red, red-yellow
  - Size 130x130, black, grey, red, red-yellow
- Snap-on handles with round escutcheon plate
  - Black
  - Black, nose-type
- Screw mounting pistol type handle
  - Black or red
- Screw mounting double lever handle
  - Black or red
- Padlockable handle knob, without front plate
  - Black, red-yellow
- Round padlockable handles for screw mounting on door
  - Size 64x64, black, red-yellow
  - Size 90x90, black, red-yellow

## Front plates

- Front plate, without engraving
  - Size 30x30, silver, yellow
  - Size 48x48, silver, yellow
  - Size 64x64, silver, yellow
  - Size 90x90, silver, yellow
  - Size 130x130, silver, yellow
  - Size H=45mm, W=54mm, grey

## Additional lettering plate

- Without engraving
  - Size 30x30, black or grey frame
  - Size 48x48, black or grey frame
  - Size 64x64, black or grey frame

## Other accessories

- Front ring
- Shaft sealing
- Spare key
- Protective rear cover
- Nut spanner
- Adaptor ring
- Base mounting kit



► Front plates

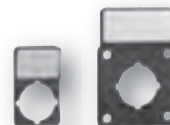

► Additional lettering plate



Door mounted

DIN-rail mounted

OM	ON	OL40	OL80...OL160	OL200	ON_M
x	x	x			
	x	x			
			x		
				x	
x	x	x			
x					
			x	x	
				x	
	x	x			x
	x	x			
			x		
x	x	x			
			x		
				x	x
x	x	x			
	x	x	x		
	x	x		x	
	x				
x	x				
	x				



▶ Front ring



▶ Spare key



▶ Protective rear cover



▶ Nut spanner



▶ Adaptor ring  
22.5/30.5 mm

# Special CAM SWITCHES

To be specified by the Camweb  
configuration tool

[a.salesconfigurator.com](http://a.salesconfigurator.com)

Camline

## Mounting

### Door mounted

Snap-on mounted handle

Padlockable

Round, padlockable

Square, padlockable

Screw mounted handle

Round, padlockable

Square, padlockable

Round front ring

Key operated handle

Cylinder lock

Push button lock

Pistol type handle

Double lever handle

### Base mounted

Snap-on mounted handle

Padlockable

Screw mounted handle

Door clutch

## Type of contacts

Normal Number of contacts

Double gang (Tandem) Number of contacts

Triple gang Number of contacts

Long shaft Number of contacts

## Connections

Standard box (tunnel) terminals

Fast on clips

Double fast on clips

Lug terminals

## Other features

Spring return function

Metallic camshaft

Gold contacts

Enclosed cam switches

Padlockable handle range





**Door mounted**

**DIN-rail mounted**

	OM	ON	OL40	OL80...OL160	OL200	ON_M
	x	x	x			
		x	x			
		x	x			
		x	x			
	x	x	x	x	x	
				x	x	
				x	x	
	x	x	x			
		x	x	x	x	
		x	x	x	x	
				x	x	
				x	x	
		x	x			x
		x	x			
		x	x	x	x	
		x	x	x	x	
		x	x	x	x	
	max. 16	max. 20 max. 40 max. 60 max. 60	max. 20 max. 40 max. 60 max. 60			max. 6
	x	x	x	x		x
	x	x	x			
	x	x	x			
				x	x	
	x	x	x	x	x	x
		x	x			
	x	x	x	x	x	x
		x				

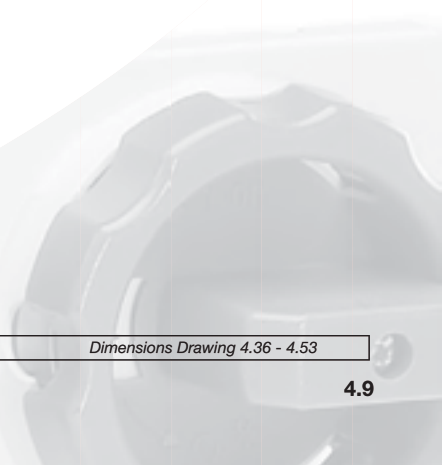

# SOLUTIONS



Camline

## Standard handles

Cam switches up to the size OL40 are delivered with snap-on handles for 22.5 mm door drilling, while the larger handle sizes are screw mounted (4-hole mounting). Screw mounted handles are available for all sizes and they can be specified by the Camweb configurator. Protection degree IP65, NEMA 4X.



## Special handles for large switches

Pistol type handles and double lever handles are available for the sizes OL80...OL200. Protection degree is the same as for the front plate.



## Padlockable handles

### Padlockable handle knob

Optional handle for replacing the standard knob handle. Two padlocks with bail diameter of 6 mm or three padlocks with 4 mm bail diameter. Padlocking is possible every 90 degrees at 9, 12, 3 and 6 o'clock positions. Available for the sizes ON...OL40 (6 mm shaft diameter). Suitable for both snap-on and screw mounted handles. Protection degree IP65, NEMA 4X.



### Round padlockable handle

Optional handle with two locking positions and 90 degrees movement only. Locking positions: 9 o'clock (O-OFF) and 12 o'clock (1-ON) or when the switch is rotated 90 degrees: 12 o'clock (O-OFF) and 3 o'clock (1-ON). For maximum three padlocks with max. 8 mm bail diameter. Available for sizes ON...OL160 as a snap-on or screw mounted version. Protection degree IP65, NEMA 4X.

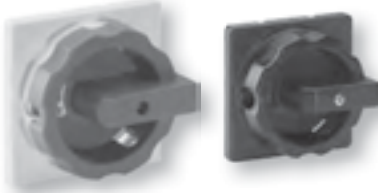

### Square padlockable handle

The programmable square handle, with one to four possible padlocking positions at certain angles, can be specified by the Camweb configurator. For maximum three padlocks with max. 8 mm bail diameter for sizes ON...OL40 or 8 mm for sizes OL80...200, screw mounted. Protection degree IP65, NEMA 4X.



## Interlocking solutions

### Key operated cam switches

Key switches are operated by the key, which functions as the operating handle. Special key codes are available on request. The standard key removal is possible at 12 o'clock, or in other positions, as described in the ordering details. The delivery contains two keys. In non-standard switches the key removal positions can be specified by the Camweb configurator. The key switch is available for the sizes OM...OL40, also enclosed switches. Protection degree IP54, NEMA 1.

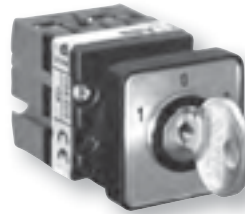

### Key interlocked cam switches with cylinder interlock

The operation of the cam switch is interlocked with the cylinder lock below the switch. The interlocking is possible in one to four selected positions by the key. The possible interlocking positions are specified by the Camweb configurator. The delivery contains two keys. Available for the sizes ON...OL160. Protection degree IP65, NEMA 4X.



### Push button interlock

The push button releases the cam switch in one or several positions specified by the Camweb configurator. Auxiliary contacts are possible to operate with the push button. Protection degree IP65, NEMA 4X.





# SOLUTIONS

Camlin

## Base mounted switches

### Modular cam switches

Modular cam switches are available for up to 6 contacts according to the DIN-rail component standard. Clip-on mounting on DIN-rail. Protection degree IP20.



### Base mounted cam switches

Base mounted cam switches are recommended to be specified for the desired shaft length or panel depth by the Camweb configurator. The shaft can be specified with the door clutch, which locks the door in the ON-position. Mounting kit type ONZ74 for door-mounted ON cam switches can be ordered as optional extra with shaft length 200 mm and DIN rail

Base mounted cam switches with direct mounted handles are available as special cam switches. The standard or padlockable handle is fixed on the cam switch.

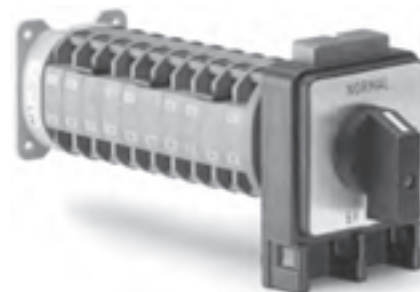

## Cam switches with high number of contacts

### Double and triple gang switches

Double and triple gang switches (2 x 20 or 3 x 20 contacts) are specified by the Camweb configurator for door and base mounting with the handle size from 64 mm. Padlocking with square padlockable handles. Screw mounting.

### Metallic shaft

ON cam switches are available with metallic shafts allowing max. 60 auxiliary contacts to be assembled in one long cam switch. Specification by the Camweb configurator.

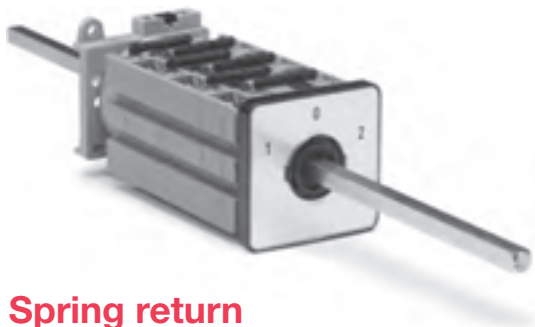

## Spring return

The spring return movement is always 30 degrees. The next step of the static position of spring return needs to be 90 degrees if not symmetrical design.



## Round front ring

The round front ring replaces the square escutcheon plate. The assembly do not include position indications. The round front ring is available as special switch configured by the Camweb.



## Terminations

### Quick connects

Cam switches are available with quick connects 6.3 x 0.8 or double FASTON-quick connects 2 x 3.15. Specification by the Camweb configurator.



### Lug terminals

The OL80...160 cam switches are normally provided with protected box type termination. Lug terminals for cable lugs are specified by the Camweb configurator.



### Gold contacts

The OM and ON switches can be supplied with gold contacts. Specification recommended by the Camweb configurator.



# CamLine

## Rotary cam switches

### Technical data

## Technical data

### Ratings according to UL and CSA

		Size	OM	ON	OL40	OL80	OL125	OL160	OL200	
Maximum operating voltage	CSA/UL	V	300	600	600	600	600	600	600	
Ampere rating	General use	CSA/UL	A	10	25	40	80	125	170	200
Rated power	3-phase	240V	HP	1	2	10	30	40	40	60
		480V	HP	-	5	20	30	40	50	120
		600V	HP	-	5	20	30	40	50	120
	1-phase	120V	HP	0.33	1	2	7.5	10	10	-
		240V	HP	1	1	3	15	20	20	-
Short circuit ratings										
Maximum prospective fault current		kA	1	10	10	10	10	10	10	
Maximum fuse size		A	16	35(RK5)	50(RK5)	100(RK5)	150(RK5)	200(RK5)	400(RK5)	
Switching frequency		cycles/hour	150	150	150	150	150	150	150	
Connecting screws		M	2.5	3.5	5	5	5	5	10	
Max cable cross section		mm <sup>2</sup>	1.5	4	6	70	70	70	150	
		AWG	14	14-12	14-8	12-2/0	12-2/0	12-2/0	kcmil 300	
Min switching current AC/DC		mA	5	5	5	5	5	5	5	
Minimum voltage AC/DC		V	5	5	5	5	5	5	5	



# CamLine

## Rotary cam switches

### Technical data

## Technical data

### Ratings according to IEC60947

		Size	OM	ON	OL40	OL80	OL125	OL160	OL200
Impulse withstand voltage	U <sub>imp</sub>	kV	-	-	6	6	6	6	6
Rated operational voltage	U <sub>e</sub>	V	500	690	690	690	690	690	690
Rated insulation voltage		V	250	400	690	690	690	690	690
Rated thermal current I <sub>th</sub>		A	10	25	45	115	150	175	315
Rated conditional short circuit current	I <sub>p</sub> (r.m.s.)	kA	1	10	10	10	10	10	10
Max back-up fuse link		A	10	25	40	125	200	200	250
Rated short time withstand current (r.m.s)	3s	A		100	360	800	1280	1280	1600
	10s	A		60	200	420	700	700	1000
	30s	A		32	120	260	400	400	600
	60s	A		30	80	160	280	280	400
Rated operational current	I <sub>e</sub>	A	10	25	45	115	150	160	250
	AC1 400V	A	10	25	45	115	150	170	250
	AC21 400V	A	10	25	45	115	150	170	250
	AC11 220-240V	A	2.5	5.5	14	30	45	45	80
	380-440V	A	-	3.5	6.0	30	45	45	80
	500V	A	-	4.5	7.0	28	40	40	70
	AC22 220-500V	A	10	20	40	100	150	170	250
	660-690V	A	-	20	40	80	100	100	125
Rated operational current	1/2/3 (contact in series)								
Time constant 0...1ms	VDC1 24/48/72	A	10	20	40	115	130	150	250
	40/80/120	A	6	16	32	100	115	130	200
	60/120/180	A	2.5	4.2	7.5	11	15	17	23
	110/220/330	A	0.7	1	1.7	-	-	-	-
	220/440/660	A	0.3	0.37	0.48	-	-	-	-
	440/660	A	-	0.22	0.25	-	-	-	-
Rated operational current	1/2/3 (contact in series)								
Time constant 1...50 ms	VDC1 24/48/72	A	6	10	32	100	115	130	200
	30/60/90	A	3	4.5	11	33	36	40	50
	40/80/120	A	1	1.7	4	6	7	7.8	8.5
	60/120/180	A	0.7	0.8	1.5	1.8	2	2.2	-
	110/220/330	A	0.3	0.4	0.6	-	-	-	-
Rated operational power									
AC23 3 ph.	220-240V	kW	1.8	2.6	7.5	30	37	37	56
	380-440V	kW	3	7.5	15	45	75	75	75
	500V	kW	-	4.8	15	55	75	90	85
	660-690V	kW	-	4.8	15	45	50	55	90
AC23 1 ph.	110V	kW	0.37	0.5	2.5	5.5	9	11	14
	220-240V	kW	0.75	0.9	4	15	20	22	30
	400V	kW	1.1	1.5	7.5	22	35	37	45
Rated operational power									
AC2 3 ph.	220-240V	kW	2.5	3.5	11	30	35	37	70
	380-440V	kW	-	6	18.5	45	50	55	95
	500V	kW	-	6	18.5	55	65	75	103
	660-690V	kW	-	6	18.5	55	65	55	110



# CamLine

## Rotary cam switches

### Ordering details

#### ON - OFF switches

Black handle and front plate with position indication are included.

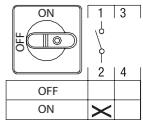

O\_A1\_

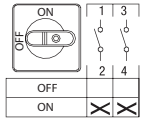

O\_A2\_

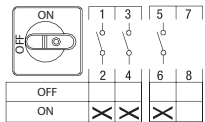

O\_A3\_

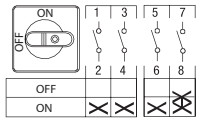

O\_A4\_

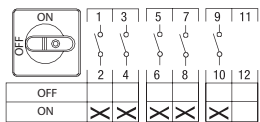

O\_A5\_

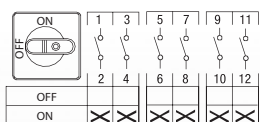

O\_A6\_

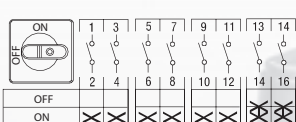

O\_A8\_

Function	Number of poles	Rated thermal current [A]	Catalogue number	List price
----------	-----------------	---------------------------	------------------	------------

Step angle 90°, O-position: 9 o'clock

Door mounted

OFF - ON	1	10	OMA1PBA	
	2	10	OMA2PBA	
	3	10	OMA3PBA	
	4	10	OMA4PBA	
	5	10	OMA5PBA	
	6	10	OMA6PBA	

OFF - ON	1	25	ONA1PBA	
	2	25	ONA2PBA	
	3	25	ONA3PBA	
	4	25	ONA4PBA	
	5	25	ONA5PBA	
	6	25	ONA6PBA	
	8	25	ONA8PBA	

OFF - ON	1	40	OL40A1PBA	
	2	40	OL40A2PBA	
	3	40	OL40A3PBA	
	4	40	OL40A4PBA	
	6	40	OL40A6PBA	
	8	40	OL40A8PBA	

O - I	1	80	OL80A1RB	
	2	80	OL80A2RB	
	3	80	OL80A3RB	
	4	80	OL80A4RB	
	6	80	OL80A6RB	
	8	80	OL80A8RB	

O - I	1	125	OL125A1RB	
	2	125	OL125A2RB	
	3	125	OL125A3RB	
	4	125	OL125A4RB	
	6	125	OL125A6RB	
	8	125	OL125A8RB	

O - I	1	160	OL160A1RB	
	2	160	OL160A2RB	
	3	160	OL160A3RB	
	4	160	OL160A4RB	
	6	160	OL160A6RB	
	8	160	OL160A8RB	

O - I	1	200	OL200A1RB	
	2	200	OL200A2RB	
	3	200	OL200A3RB	
	4	200	OL200A4RB	
	6	200	OL200A6RB	
	8	200	OL200A8RB	

DIN-rail mounted

OFF - ON	1	25	ONA1MA	
	2	25	ONA2MA	
	3	25	ONA3MA	
	6	25	ONA6MA	

Key operated, withdrawable in both positions, step angle 90°, O-position: 9 o'clock

Door mounted

OFF - ON	1	10	OMA1KBA	
	3	10	OMA3KBA	

OFF - ON	1	25	ONA1KBA	
	2	25	ONA2KBA	
	3	25	ONA3KBA	

OFF - ON	1	40	OL40A1KBA	
	2	40	OL40A2KBA	
	3	40	OL40A3KBA	
	4	40	OL40A4KBA	

<sup>1)</sup> 4th pole early make, late break in A4\_ and A8\_ types  
<sup>2)</sup> 7th and 8th pole early make, late break



# CamLine

## Rotary cam switches

### Ordering details

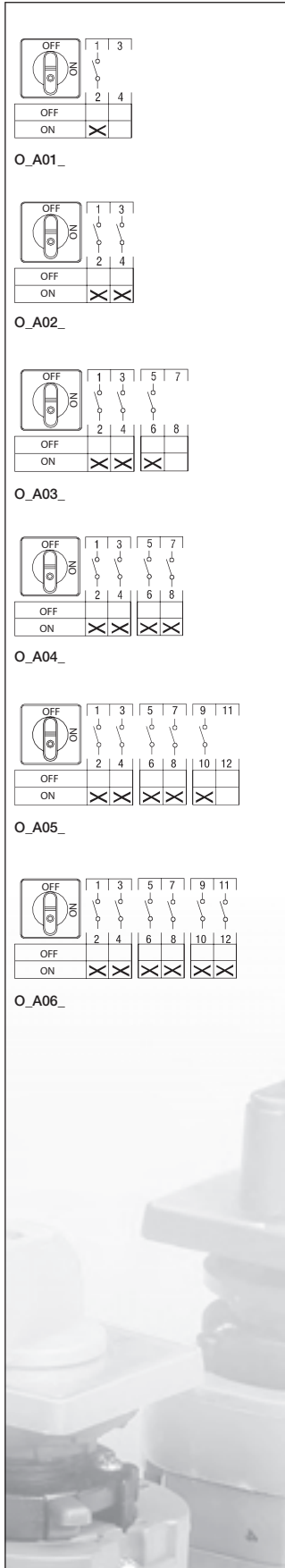

### ON - OFF switches

Black handle and front plate with position indication are included.  
The type and the ordering number are for one piece.

Function	Number of poles	Rated current [A]	Catalogue number	List price
<b>Step angle 90°, O-position: 12 o'clock</b>				
<b>Door mounted</b>				
OFF - ON	1	10	OMA01PBA	
	2	10	OMA02PBA	
	3	10	OMA03PBA	
	4	10	OMA04PBA	
	5	10	OMA05PBA	
	6	10	OMA06PBA	
OFF - ON	1	25	ONA01PBA	
	2	25	ONA02PBA	
	3	25	ONA03PBA	
	4 <sup>1)</sup>	25	ONA04PBA	
	5	25	ONA05PBA	
	6	25	ONA06PBA	
<b>DIN-rail mounted</b>				
OFF - ON	1	25	ONA01MA	
	2	25	ONA02MA	
	3	25	ONA03MA	
	6	25	ONA06MA	
<b>Key operated, withdrawable in both positions, step angle 90°, O-position: 12 o'clock</b>				
<b>Door mounted</b>				
OFF - ON	1	10	OMA01KBA	
	3	10	OMA03KBA	
OFF - ON	1	25	ONA01KBA	
	3	25	ONA03KBA	

<sup>1)</sup> 4th pole with simultaneous contacts



# CamLine

## Rotary cam switches

### Ordering details

#### Change-over switches

Black handle and front plate with position indication are included.

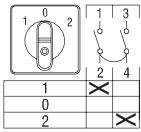

O\_U1\_

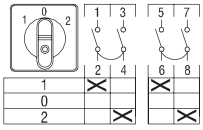

O\_U2\_

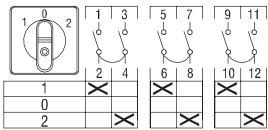

O\_U3\_

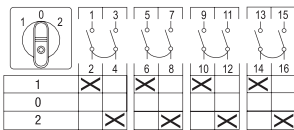

O\_U4\_

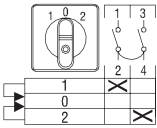

O\_URR1\_

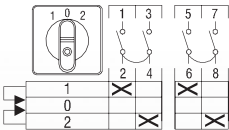

O\_URR2\_

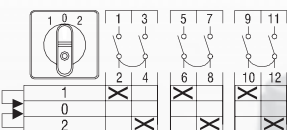

O\_URR3\_

Function	Number of poles	Rated current [A]	Catalogue number	List price
<b>Step angle 60°, with 0-position</b>				
<b>Door mounted</b>				
1 - 0 - 2	1	10	OMU1PB	
	2	10	OMU2PB	
	3	10	OMU3PB	
	4	10	OMU4PB	
1 - 0 - 2	1	25	ONU1PB	
	2	25	ONU2PB	
	3	25	ONU3PB	
	4	25	ONU4PB	
	5	25	ONU5PB	
	6	25	ONU6PB	
1 - 0 - 2	1	40	OL40U1PB	
	2	40	OL40U2PB	
	3	40	OL40U3PB	
	4	40	OL40U4PB	
	5	40	OL40U5PB	
	6	40	OL40U6PB	
1 - 0 - 2	1	80	OL80U1RB	
	2	80	OL80U2RB	
	3	80	OL80U3RB	
	4	80	OL80U4RB	
1 - 0 - 2	1	125	OL125U1RB	
	2	125	OL125U2RB	
	3	125	OL125U3RB	
	4	125	OL125U4RB	
1 - 0 - 2	1	160	OL160U1RB	
	2	160	OL160U2RB	
	3	160	OL160U3RB	
	4	160	OL160U4RB	
1 - 0 - 2	1	200	OL200U1RB	
	2	200	OL200U2RB	
	3	200	OL200U3RB	
	4	200	OL200U4RB	
<b>DIN-rail mounted</b>				
1 - 0 - 2	1	25	ONU1M	
	2	25	ONU2M	
	3	25	ONU3M	
	4	25	ONU4M	
<b>Door mounted</b>				
1 - 0 - 2	1	10	OMU1KB	
	3	10	OMU3KB	
1 - 0 - 2	1	25	ONU1KB	
	3	25	ONU3KB	
	4	25	ONU4KB	
1 - 0 - 2	1	40	OL40U1KB	
	2	40	OL40U2KB	
	3	40	OL40U3KB	
	4	40	OL40U4KB	
<b>1<sub>R</sub> - 0 - 2<sub>R</sub>, with two sided spring return, step angle 60°</b>				
<b>Door mounted</b>				
1R - 0 - 2R	1	10	OMURR1PB	
	3	10	OMURR3PB	
1R - 0 - 2R	1	25	ONURR1PB	
	2	25	ONURR2PB	
	3	25	ONURR3PB	
	4	25	ONURR4PB	
	5	25	ONURR5PB	
1R - 0 - 2R	1	40	OL40URR1PB	
	2	40	OL40URR2PB	
	3	40	OL40URR3PB	
	4	40	OL40URR4PB	
	5	40	OL40URR5PB	
<b>DIN-rail mounted</b>				
1R - 0 - 2R	1	25	ONURR1M	



# CamLine

## Rotary cam switches

### Ordering details

O\_WS1\_

O\_WS2\_

O\_WS3\_

O\_WS4\_

### Change-over switches

Black handle and front plate with position indication are included.

Function	Number of poles	Rated current [A]	Catalogue number	Price List
<b>Without 0-position, step angle 60°</b>				
<b>Door mounted</b>				
1 - 2	1	10	OMWS1PB	
	2	10	OMWS2PB	
	3	10	OMWS3PB	
	4	10	OMWS4PB	
1 - 2	1	25	ONWS1PB	
	2	25	ONWS2PB	
	3	25	ONWS3PB	
	4	25	ONWS4PB	
	5	25	ONWS5PB	
	6	25	ONWS6PB	
	7	25	ONWS7PB	
	8	25	ONWS8PB	
	9	25	ONWS9PB	
	10	25	ONWS10PB	
1 - 2	1	40	OL40WS1PB	
	2	40	OL40WS2PB	
	3	40	OL40WS3PB	
	4	40	OL40WS4PB	
	5	40	OL40WS5PB	
	6	40	OL40WS6PB	
	7	40	OL40WS7PB	
	8	40	OL40WS8PB	
	9	40	OL40WS9PB	
	10	40	OL40WS10PB	
1 - 2	1	40	OL40WS1PB	
	2	40	OL40WS2PB	
	3	40	OL40WS3PB	
	4	40	OL40WS4PB	
1 - 2	1	80	OL80WS1RB	
	2	80	OL80WS2RB	
	3	80	OL80WS3RB	
	4	80	OL80WS4RB	
1 - 2	1	125	OL125WS1RB	
	2	125	OL125WS2RB	
	3	125	OL125WS3RB	
	4	125	OL125WS4RB	
1 - 2	1	160	OL160WS1RB	
	2	160	OL160WS2RB	
	3	160	OL160WS3RB	
	4	160	OL160WS4RB	
1 - 2	1	200	OL200WS1RB	
	2	200	OL200WS2RB	
	3	200	OL200WS3RB	
	4	200	OL200WS4RB	
<b>DIN-rail mounted</b>				
1 - 2	1	25	ONWS1M	
	2	25	ONWS2M	
	3	25	ONWS3M	
	4	25	ONWS4M	

### Wiring diagram (O\_WS\_)

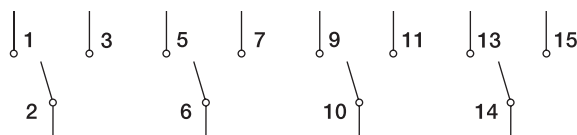





# CamLine

## Rotary cam switches

### Ordering details

### Change-over switches

Black handle and front plate with position indication are included.

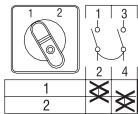

O\_WC1\_

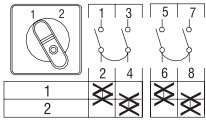

O\_WC2\_

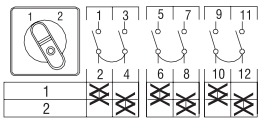

O\_WC3\_

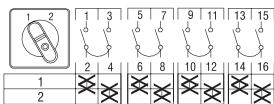

O\_WC4\_

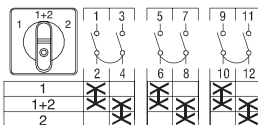

O\_UC3\_

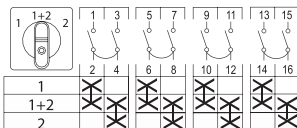

O\_UC4\_

Function	Number of poles	Rated current [A]	Catalogue number	List price
<b>Door mounted</b>				
<b>With overlapping contacts</b>				
1-2	1	10	OMWC1PB	
	2	10	OMWC2PB	
	3	10	OMWC3PB	
	4	10	OMWC4PB	
1-2	1	25	ONWC1PB	
	2	25	ONWC2PB	
	3	25	ONWC3PB	
	4	25	ONWC4PB	
1-2	1	40	OL40WC1PB	
	2	40	OL40WC2PB	
	3	40	OL40WC3PB	
	4	40	OL40WC4PB	
1-2	1	80	OL80WC1RB	
	2	80	OL80WC2RB	
	3	80	OL80WC3RB	
	4	80	OL80WC4RB	
1-2	1	125	OL125WC1RB	
	2	125	OL125WC2RB	
	3	125	OL125WC3RB	
	4	125	OL125WC4RB	
1-2	1	160	OL160WC1RB	
	2	160	OL160WC2RB	
	3	160	OL160WC3RB	
	4	160	OL160WC4RB	
1-2	1	200	OL200WC1RB	
	2	200	OL200WC2RB	
	3	200	OL200WC3RB	
	4	200	OL200WC4RB	
<b>With common center position and with overlapping contacts</b>				
1 - (1 + 2) - 2	3	25	ONUC3PB	
	4	25	ONUC4PB	
1 - (1 + 2) - 2	3	40	OL40UC3PB	
	4	40	OL40UC4PB	
1 - (1 + 2) - 2	3	80	OL80UC3RB	
	4	80	OL80UC4RB	
1 - (1 + 2) - 2	3	125	OL125UC3RB	
	4	125	OL125UC4RB	
1 - (1 + 2) - 2	3	160	OL160UC3RB	
	4	160	OL160UC4RB	
1 - (1 + 2) - 2	3	200	OL200UC3RB	
	4	200	OL200UC4RB	

#### Wiring diagram (O\_WC\_, O\_UC\_)

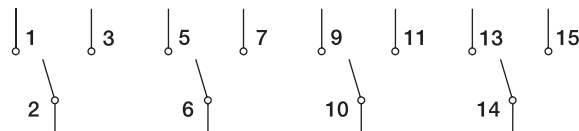



# CamLine

## Rotary cam switches

### Ordering details

### Bypass switches

Black handle and front plate with position indication are included.

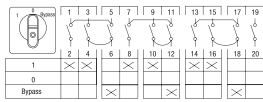

O\_WS36\_

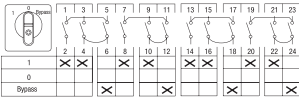

O\_WS48\_

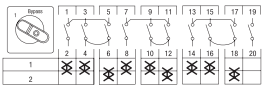

O\_PW36\_

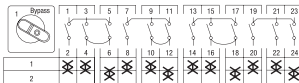

O\_PW48\_

Function	Number of poles	Rated current [A]	Catalogue number	List price
<b>Door mounted</b>				
<b>Without overlapping, 3 and 4- pole network</b>				
1 - 0 - Bypass	3 / 6	25	ONWS36PB	
0	4 / 8	25	ONWS48PB	
1 - 0 - Bypass	3 / 6	40	OL40WS36PB	
	4 / 8	40	OL40WS48PB	
1 - 0 - Bypass	3 / 6	80	OL80WS36RB	
	4 / 8	80	OL80WS48RB	
1 - 0 - Bypass	3 / 6	125	OL125WS36RB	
	4 / 8	125	OL125WS48RB	
1 - 0 - Bypass	3 / 6	160	OL160WS36RB	
	4 / 8	160	OL160WS48RB	
1 - 0 - Bypass	3 / 6	200	OL200WS36RB	
	4 / 8	200	OL200WS48RB	
<b>With overlapping, 3 and 4- pole network</b>				
1 - Bypass	3 / 6	25	ONPW36PB	
	4 / 8	25	ONPW48PB	
1 - Bypass	3 / 6	40	OL40PW36PB	
	4 / 8	40	OL40PW48PB	
1 - Bypass	3 / 6	80	OL80PW36RB	
	4 / 8	80	OL80PW48RB	
1 - Bypass	3 / 6	125	OL125PW36RB	
	4 / 8	125	OL125PW48RB	
1 - Bypass	3 / 6	160	OL160PW36RB	
	4 / 8	160	OL160PW48RB	
1 - Bypass	3 / 6	200	OL200PW36RB	
	4 / 8	200	OL200PW48RB	

### Wiring diagram, bypass switches

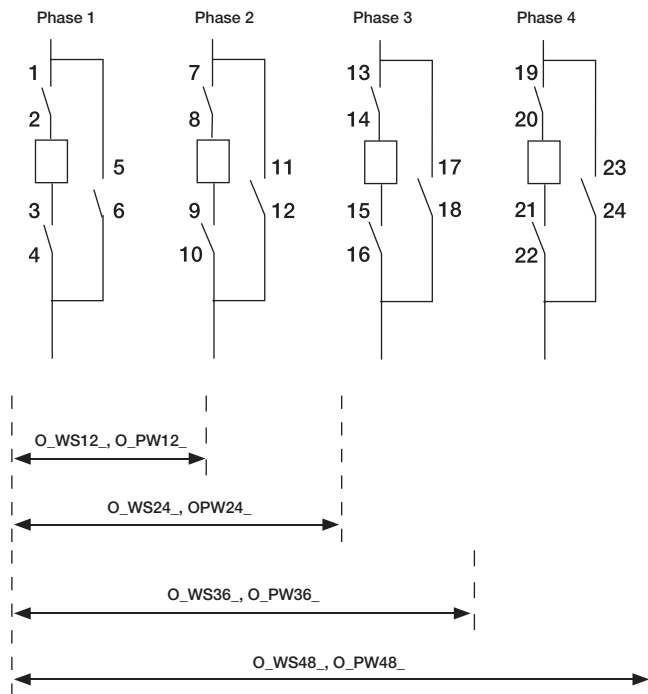



# CamLine

## Rotary cam switches

### Ordering details

#### Multistep switches

Black handle and front plate with position indication are included.

Step angle 30°

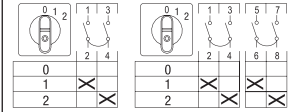

O\_SO21\_ O\_SO22\_

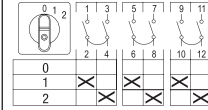

O\_SO23\_

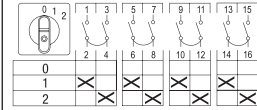

O\_SO24\_

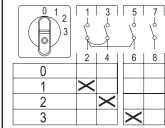

O\_SO31\_

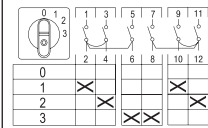

O\_SO32\_

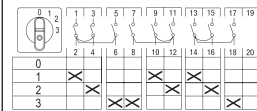

O\_SO33\_

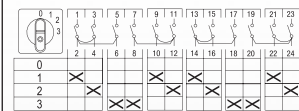

O\_SO34\_

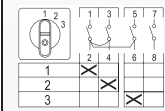

O\_ST31\_

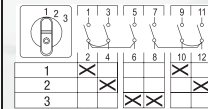

O\_ST32\_

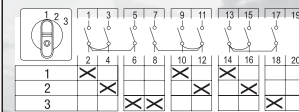

O\_ST33\_

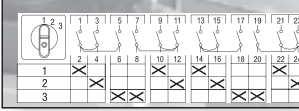

O\_ST34\_

Function	Number of poles	Rated current [A]	Catalogue number	List price
----------	-----------------	-------------------	------------------	------------

#### 2- step, with O-position

##### Door mounted

0 - 1 - 2	1	10	OMSO21PB	
	2	10	OMSO22PB	
	3	10	OMSO23PB	
	4	10	OMSO24PB	
0 - 1 - 2	1	25	ONSO21PB	
	2	25	ONSO22PB	
	3	25	ONSO23PB	
	4	25	ONSO24PB	
	6	25	ONSO26PB	
	0 - 1 - 2	1	40	OL40SO21PB
2		40	OL40SO22PB	
3		40	OL40SO23PB	
4		40	OL40SO24PB	
6		40	OL40SO26PB	
0 - 1 - 2		1	80	OL80SO21RB
	1	125	OL125SO21RB	
	1	160	OL160SO21RB	
	1	200	OL200SO21RB	

##### DIN-Rail mounted

0 - 1 - 2	1	25	ONSO21M	
	2	25	ONSO22M	

#### 3- step, with O-position

##### Door mounted

0 - 1 - 2 - 3	1	10	OMSO31PB	
	2	10	OMSO32PB	
	3	10	OMSO33PB	
	4	10	OMSO34PB	
0 - 1 - 2 - 3	1	25	ONSO31PB	
	2	25	ONSO32PB	
	3	25	ONSO33PB	
	4	25	ONSO34PB	
	5	25	ONSO35PB	
0 - 1 - 2 - 3	1	40	OL40SO31PB	
	2	40	OL40SO32PB	
	3	40	OL40SO33PB	
	4	40	OL40SO34PB	
	5	40	OL40SO35PB	
0 - 1 - 2 - 3	1	80	OL80SO31RB	
	1	125	OL125SO31RB	
	1	160	OL160SO31RB	
	1	200	OL200SO31RB	

##### DIN-rail mounted

0 - 1 - 2 - 3	1	25	ONSO31M	
---------------	---	----	---------	--

#### 3- step, without O-position

##### Door mounted

1 - 2 - 3	1	10	OMST31PB	
	2	10	OMST32PB	
	3	10	OMST33PB	
	4	10	OMST34PB	
1 - 2 - 3	1	25	ONST31PB	
	2	25	ONST32PB	
	3	25	ONST33PB	
	4	25	ONST34PB	

##### DIN-rail mounted

1 - 2 - 3	1	25	ONST31M	
-----------	---	----	---------	--



# CamLine

## Rotary cam switches

### Ordering details

### Multistep switches

Black handle and front plate with position indication are included.  
**Step angle 30°**

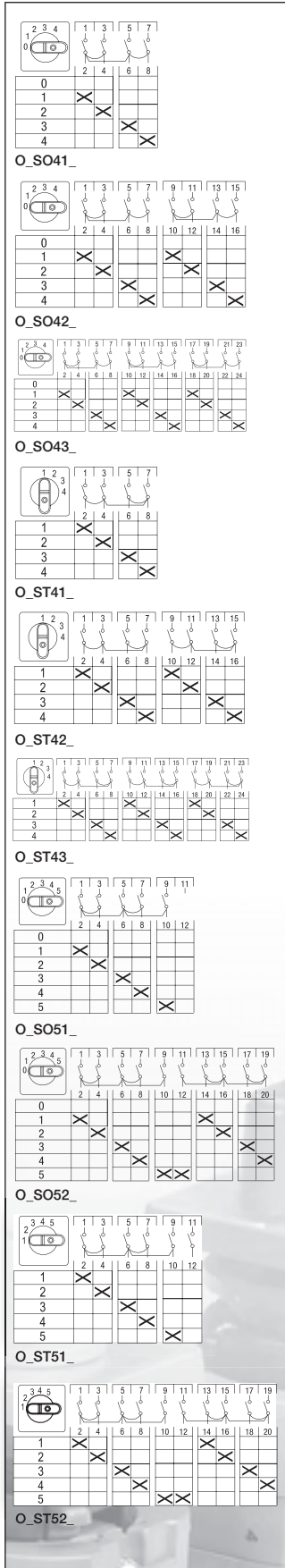

Function	Number of poles	Rated current [A]	Catalogue number	List price
<b>3- step, without O-position</b>				
<b>Door mounted</b>				
1 - 2 - 3	1	40	OL40ST31PB	
	2	40	OL40ST32PB	
	3	40	OL40ST33PB	
	4	40	OL40ST34PB	
	6	40	OL40ST36PB	
	8	40	OL40ST38PB	
<b>4- step, with O-position</b>				
<b>Door mounted</b>				
0 - 1 - 2 - 3 - 4	1	10	OMSO41PB	
	2	10	OMSO42PB	
	3	10	OMSO43PB	
0 - 1 - 2 - 3 - 4	1	25	ONSO41PB	
	2	25	ONSO42PB	
	3	25	ONSO43PB	
0 - 1 - 2 - 3 - 4	1	40	OL40SO41PB	
	2	40	OL40SO42PB	
	3	40	OL40SO43PB	
<b>4- step, without O-position</b>				
<b>Door mounted</b>				
1 - 2 - 3 - 4	1	10	OMST41PB	
	2	10	OMST42PB	
	3	10	OMST43PB	
1 - 2 - 3 - 4	1	25	ONST41PB	
	2	25	ONST42PB	
	3	25	ONST43PB	
1 - 2 - 3 - 4	1	40	OL40ST41PB	
	2	40	OL40ST42PB	
	3	40	OL40ST43PB	
<b>5- step, with O-position</b>				
<b>Door mounted</b>				
0 - 1 - 2 - 3 - 4 - 5	1	10	OMSO51PB	
	2	10	OMSO52PB	
0 - 1 - 2 - 3 - 4 - 5	1	25	ONSO51PB	
	2	25	ONSO52PB	
0 - 1 - 2 - 3 - 4 - 5	1	40	OL40SO51PB	
	2	40	OL40SO52PB	
<b>Din-rail mounted</b>				
0 - 1 - 2 - 3 - 4 - 5	1	25	ONSO51M	
<b>5- step, without O-position</b>				
<b>Door mounted</b>				
1 - 2 - 3 - 4 - 5	1	10	OMST51PB	
	2	10	OMST52PB	
1 - 2 - 3 - 4 - 5	1	25	ONST51PB	
	2	25	ONST52PB	
1 - 2 - 3 - 4 - 5	1	40	OL40ST51PB	
	2	40	OL40ST52PB	



# CamLine

## Rotary cam switches

### Ordering details

### Multistep switches

Black handle and front plate with position indication are included.

Step angle 30°

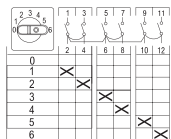

O\_SO61\_

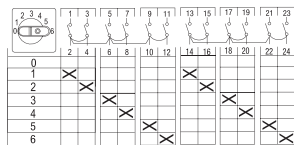

O\_SO62\_

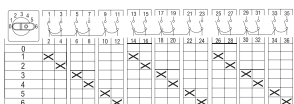

O\_SO63\_

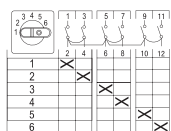

O\_ST61\_

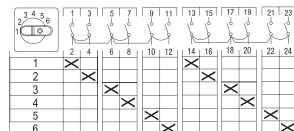

O\_ST62\_

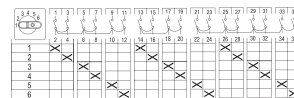

O\_ST63\_

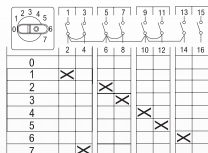

O\_SO71\_

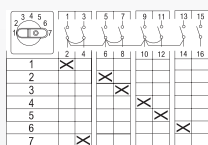

O\_ST71\_

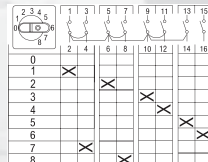

O\_SO81\_

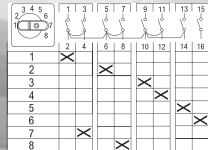

O\_ST81\_

Function	Number of poles	Rated current [A]	Catalogue number	List price
<b>Door mounted</b>				
<b>6-step, with 0-position</b>				
0 - 1 - 2 - 3 - 4 - 5 - 6	1	25	ONSO61PB	
	2	25	ONSO62PB	
	3	25	ONSO63PB	
0 - 1 - 2 - 3 - 4 - 5 - 6	1	40	OL40SO61PB	
	2	40	OL40SO62PB	
	3	40	OL40SO63PB	
<b>6-step, without 0-position</b>				
1 - 2 - 3 - 4 - 5 - 6	1	25	ONST61PB	
	2	25	ONST62PB	
	3	25	ONST63PB	
1 - 2 - 3 - 4 - 5 - 6	1	40	OL40ST61PB	
	2	40	OL40ST62PB	
	3	40	OL40ST63PB	
1 - 2 - 3 - 4 - 5 - 6	1	80	OL80ST61PB	
	1	125	OL125ST61PB	
	1	160	OL160ST61PB	
	1	200	OL200ST61PB	
<b>7-step, with 0-position</b>				
0-1-2-3-4-5-6-7	1	25	ONSO71PB	
	1	40	OL40SO71PB	
<b>7-step, without 0-position</b>				
1-2-3-4-5-6-7	1	25	ONST71PB	
	1	40	OL40ST71PB	
<b>8-step, with 0-position</b>				
0-1-2-3-4-5-6-7-8	1	25	ONSO81PB	
	1	40	OL40SO81PB	
<b>8-step, without 0-position</b>				
1-2-3-4-5-6-7-8	1	25	ONST81PB	
	1	40	OL40ST81PB	



# CamLine

## Rotary cam switches

### Ordering details

### Multistep switches

Black handle and front plate with position indication are included.

Step angle 30°

Function	Number of poles	Rated current [A]	Catalogue number	List price
<b>Door mounted</b>				
<b>9-step, with 0-position</b>				
0-1-2-3-4-5-6-7-8-9	1	25	ONSO91PB	
	1	40	OL40SO91PB	
<b>9-step, without 0-position</b>				
1-2-3-4-5-6-7-8-9	1	25	ONST91PB	
	1	40	OL40ST91PB	
<b>10-step, with 0-position</b>				
0-1-2-3-4-5-6-7-8-9-10	1	25	ONSO101PB	
	1	40	OL40SO101PB	
<b>10-step, without 0-position</b>				
1-2-3-4-5-6-7-8-9-10	1	25	ONST101PB	
	1	40	OL40ST101PB	
<b>11-step, with 0-position</b>				
0-1-2-3-4-5-6-7-8-9-10-11	1	25	ONSO111PB	
	1	40	OL40SO111PB	
<b>11-step, without 0-position</b>				
1-2-3-4-5-6-7-8-9-10-11	1	25	ONST111PB	
	1	40	OL40ST111PB	
<b>12-step, without 0-position</b>				
1-2-3-4-5-6-7-8-9-10-11-12	1	25	ONST121PB	
	1	40	OL40ST121PB	

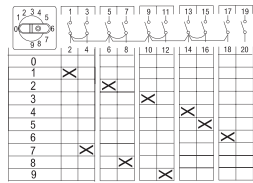

O\_SO91\_

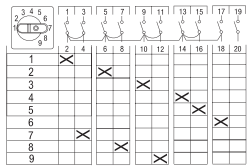

O\_ST91\_

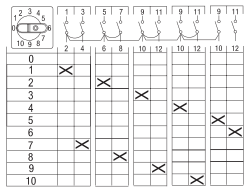

O\_SO101\_

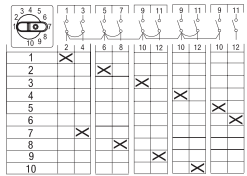

O\_ST101\_

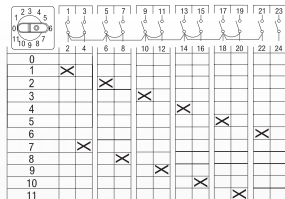

O\_SO111\_

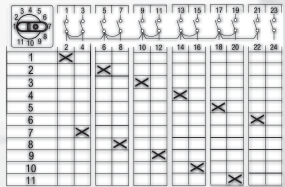

O\_ST111\_

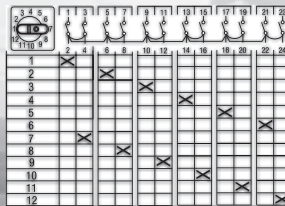

O\_ST121\_



# CamLine

## Rotary cam switches

### Ordering details

### Motor control switches

Black handle and front plate with position indication are included.

Step angle 60°

Function	Number of poles	Rated current [A]	Motor rating	Catalogue number	List price
----------	-----------------	-------------------	--------------	------------------	------------

### Ventilation switches

Door mounted

A - 0 - 1/2 - 1/1	2	25	600V [HP] 5	ONST301PB	
	2	40	20	OL40ST301PB	

DIN-rail mounted

A - 0 - 1/2 - 1/1	2	25	5	ONST301M	
-------------------	---	----	---	----------	--

### Reversing switches

Door mounted, 3 phase

			600V [HP]	
1 - 0 - 2	2	25	5	ONW2PB
	2	40	20	OL40W2PB
	2	80	30	OL80W2RB
1 - 0 - 2	3	25	5	ONW3PB
	3	40	20	OL40W3PB

Door mounted, 1 phase

			240V [HP]	
1 - 0 - 2	3	25	1	ON6PBS5487
	3	40	3	OL406PBS12326

### Star-delta switches

Door mounted

			600V [HP]	
0 - Y - Δ	3	25	5	ONSDPB
	3	40	20	OL40SDPB
	3	80	30	OL80SDRB
	3	125	40	OL125SDRB
	3	160	50	OL160SDRB
	3	200	120	OL200SDRB

### Pole-change switches (Dahlander)

Winding for 2 speeds, one direction, 0 - A - AYY

Door mounted

			600V [HP]	
0 - 1 - 2	3	25	5	ONP12PB
	3	40	20	OL40P12PB
1 - 0 - 2	3	80	30	OL80P012RB
	3	125	40	OL125P012RB
	3	160	50	OL160P012RB
	3	200	120	OL200P012RB

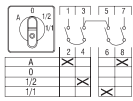

O\_ST301\_

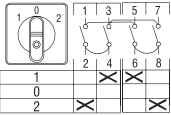

O\_W2\_

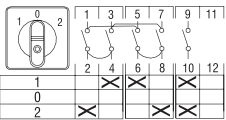

O\_W3\_

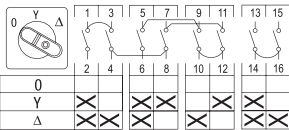

O\_SD\_, O\_SDE\_

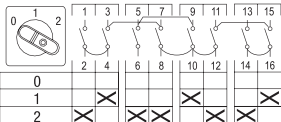

O\_P12\_

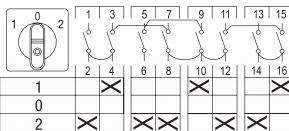

O\_P012\_

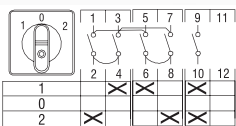

ON6PBS5487

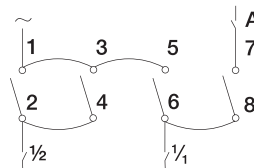

O\_ST301

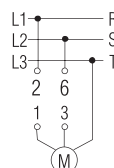

O\_W2\_

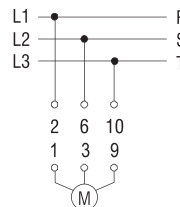

O\_W3\_

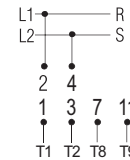

ON6PBS5487

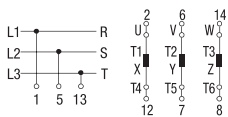

O\_SD\_, O\_SDE\_

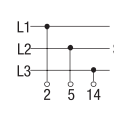

O\_P12\_

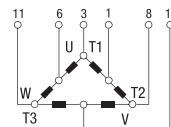

O\_P012\_



# CamLine

## Rotary cam switches

### Ordering details

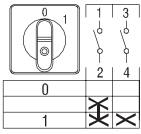

O\_SE158\_

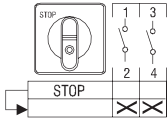

O\_SA2\_

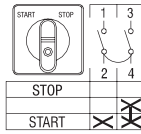

O\_SEA1\_

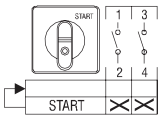

O\_SE2\_

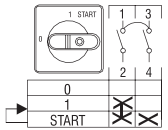

O\_SEA10\_

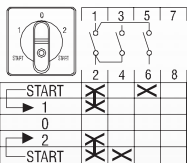

O\_UR139\_

### Motor control switches

Black handle and front plate with position indication are included.

Function	Number of poles	Rated current [A]	Catalogue number	List price
----------	-----------------	-------------------	------------------	------------

### Pumpstart switches

Step angle 60°

Door mounted

0 - 1	1	10	OMSE158PB	
	1	25	ONSE158PB	

DIN-rail mounted

0 - 1	1	25	ONSE158M	
-------	---	----	----------	--

### Stop switches

Step angle 30°, with spring return, contacts N.C.

Door mounted

0 <sub>R</sub> -Stop	2	10	OMSA2PB	
	2	25	ONSA2PB	

### Start switches

Step angle 30°, with spring return.

Door mounted

Stop-Start	1	25	ONSEA1PB	
0 <sub>R</sub> -Start	1	10	OMSE2PB	
	1	25	ONSE2PB	

Step angle 90° - 30°

0-1 <sub>R</sub> -Start	1	10	OMSEA10PB	
	1	25	ONSEA10PB	
Start-1 <sub>R</sub> -0-2 <sub>R</sub> -Start	1	25	ONUR139PB	
Start-1 <sub>R</sub> -0-2 <sub>R</sub> -Start	1	40	OL40UR139PB	

Step angle 90° - 30°, with spring return

DIN-rail mounted

0-1 <sub>R</sub> -Start	1	25	ONSEA10M	
Start-1 <sub>R</sub> -0-2 <sub>R</sub> -Start	1	25	ONUR139M	





# CamLine

## Rotary cam switches

### Ordering details

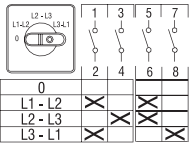

O\_V3\_

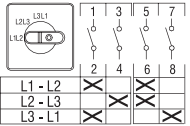

O\_VN3\_

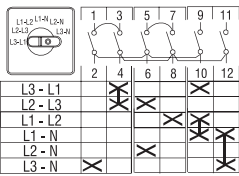

O\_VN30\_

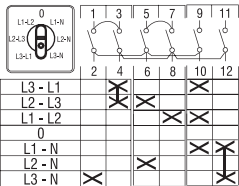

O\_V30\_

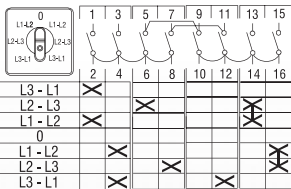

O\_V32\_

### Voltmeter switches

Black handle and front plate with position indication are included.

Function	Number of poles	Rated current [A]	Catalogue number	List price
<b>3 Positions, 3 phase -3 wire, without 0-position, step angle 45°</b>				
<b>Door mounted</b>				
L1-L2, L2-L3, L3-L1	2	10	OMVN3PB	
	2	25	ONVN3PB	
	2	25	OL40VN3PB	
<b>DIN-rail mounted</b>				
L1-L2, L2-L3, L3-L1	2	25	ONVN3M	
<b>4 Positions, 3 phase -3 wire, with 0-position, step angle 45°</b>				
<b>Door mounted</b>				
0, L1-L2, L2-L3, L3-L1	2	10	OMV3PB	
	2	25	ONV3PB	
	2	40	OL40V3PB	
<b>DIN-rail mounted</b>				
0, L1-L2, L2-L3, L3-L1	2	25	ONV3M	
<b>7 Positions, 3 phase to phase 3 phase to neutral, without 0-position, step angle 30°</b>				
<b>Door mounted</b>				
L1-L3, L2-L3, L1-L2, L1-N, L2-N, L3-N	3	10	OMVN30PB	
	3	25	ONVN30PB	
	3	40	OL40VN30PB	
<b>DIN-rail mounted</b>				
L1-L3, L2-L3, L1-L2, L1-N, L2-N, L3-N	3	25	ONVN30M	
<b>7 Positions, 3 phase to phase 3 phase to neutral, with 0-position, step angle 45°</b>				
<b>Door mounted</b>				
L1-L3, L2-L3, L1-L2, 0, L1-N, L2-N, L3-N	3	10	OMV30PB	
	3	25	ONV30PB	
	3	40	OL40V30PB	
<b>DIN-rail mounted</b>				
L1-L3, L2-L3, L1-L2, 0, L1-N, L2-N, L3-N	3	25	ONV30M	
<b>7 Positions, 3 phase to phase voltages for 2 circuits, with 0 position, step angle 45°</b>				
<b>Door mounted</b>				
L1-L3, L2-L3, L1-L2, 0, L1-L3, L2-L3, L1-L2	4	10	OMV32PB	
	4	25	ONV32PB	
	4	40	OL40V32PB	

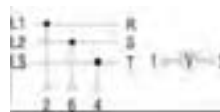

O\_VN3\_

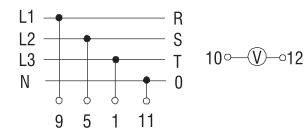

O\_VN30\_

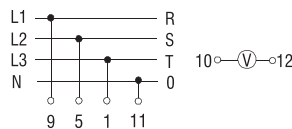

O\_V30\_

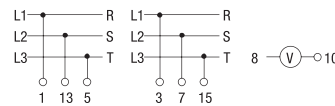

O\_V32\_



# CamLine

## Rotary cam switches

### Ordering details

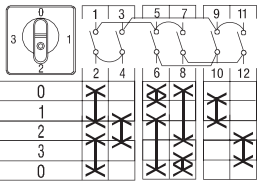

O\_AU31\_

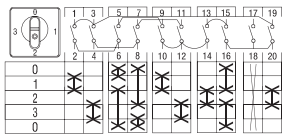

O\_AU32\_

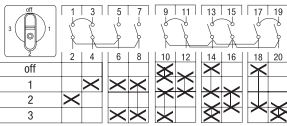

O\_VA21\_

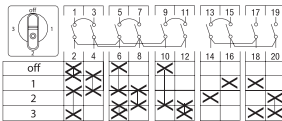

O\_AV12\_

### Ammeter switches

Black handle and front plate with position indication are included.

Function	Rated current [A]	Catalogue number	List price
----------	-------------------	------------------	------------

*For 3 current transformer circuits, with 0-position, step angle 90°*

Door mounted

Single pole

0 - 1 - 2 - 3

10

25

40

OMAU31PB

ONAU31PB

OL40AU31PB

2 pole or direct measurement in 3 phases

0 - 1 - 2 - 3

25

40

ONAU32PB

OL40AU32PB

DIN-rail mounted

Single pole

0 - 1 - 2 - 3

25

ONAU31M

### Volt-ammeter switches

Black handle and frontplate with position indication are included.

Function	Rated current [A]	Catalogue number	List price
----------	-------------------	------------------	------------

*Measuring between phases and 3 current transformers with common pole, step angle 90°*

Door mounted

OFF - 1 - 2 - 3

25

25

ONVA21PB

ONAV12PB

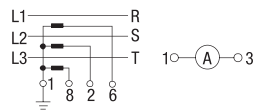

O\_AU31\_

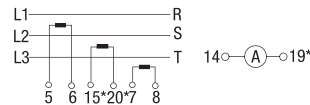

O\_AU32\_

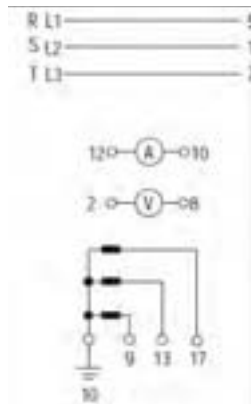

O\_VA12

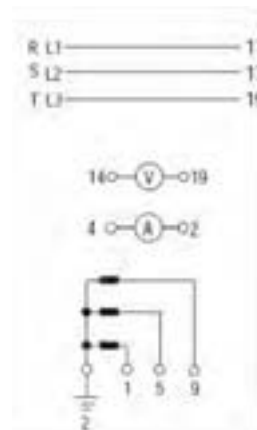

O\_AV21



# CamLine

## Rotary cam switches

### Ordering details

### Binary code switches

Black handle and front plate with position indication are included.

Function	Number of poles	Rated current [A]	Catalogue number	List price
<b>With 0-position, step angle 30°</b>				
<b>Door mounted</b>				
0 - 1 - 2 - 3	1	25	ONBC030PB	
0 - 1 - 2 - 3 - 4 - 5 - 6 - 7	1	25	ONBC070PB	
	2	25	ONBC072PB	
0 - 1 - 2 - 3 - 4 - 5 - 6 - 7 - 8 - 9	1	25	ONBC090PB	
	1	25	ONBC091PB	
	2	25	ONBC092PB	
0 - 1 - 2 - 3 - 4 - 5 - 6 - 7 - 8 - 9 - 10 - 11	1	25	ONBC0110PB	
	2	25	ONBC0112PB	

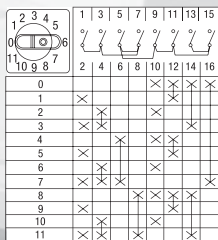
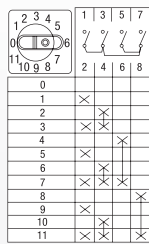
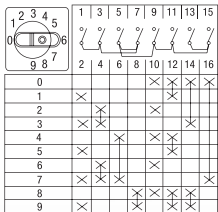
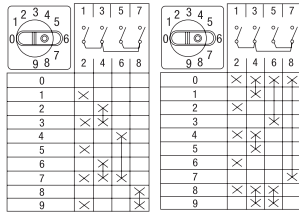
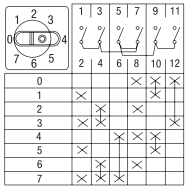
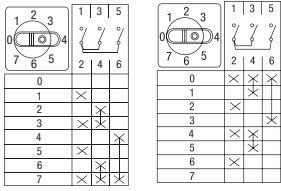



# CamLine

## Accessories

### Ordering details



### Handles

Colour	For cam switches	Catalogue number	List price
<b>Snap on handle with front plate without engraving</b> (The black handle is standard delivery in types OM, ON, and OL40)			
<b>Size 30x30</b>			
Black	OM	OMPB1	
Gray	OM	OMPG1	
Red	OM	OMPR1	
Red-yellow	OM	OMPRY1	
<b>Size 48x48</b>			
Black	ON_PB, OL40	ONPB1	
Gray	ON_PB, OL40	ONPG1	
Red	ON_PB, OL40	ONPR1	
Red-yellow	ON_PB, OL40	ONPRY1	
<b>Snap on handle with large front plate without engraving</b>			
<b>Size 64x64</b>			
Black	ON_PB, OL40	ONPLB1	
Gray	ON_PB, OL40	ONPLG1	
Red	ON_PB, OL40	ONPLR1	
Red-yellow	ON_PB, OL40	ONPLRY1	
<b>Screw mounting handle with front plate without engraving</b> (The black handle is standard delivery in types OL 80...200)			
<b>Size 90x90</b>			
Black	OL80, OL125, OL160	OLR2B	
Gray	OL80, OL125, OL160	OLR2G	
Red	OL80, OL125, OL160	OLR2R	
<b>Size 130x130</b>			
Black	OL200	OLR3B	
Gray	OL200	OLR3G	
Red	OL200	OLR3R	
<b>Snap on handle with round escutcheon plate</b>			
Black	OM	OMXB1	
Black, nose-type	OM	OMXNB1	
Black	ON_PB, OL40	ONXB1	
<b>Screw mounting pistol type handle</b>			
Black	OL80, OL125, OL160	OLZ2RB	
Red	OL80, OL125, OL160	OLZ2RR	
Black	OL200	OLZ3RB	
Red	OL200	OLZ3RR	
<b>Screw mounting double lever handle</b>			
Black	OL200	OLZ3DB	
Red	OL200	OLZ3DR	
<b>Padlockable handle knob, without front plate <sup>1)</sup></b> The standard handle knob is replaced by the padlockable handle knob. For max 2 padlocks of 6 mm hasp diameter. Standard padlocking in the OFF-position at 9 o'clock. Padlocking in the ON-position (12 o'clock) by turning the control piece 180 degrees. Padlocking in both OFF-and ON-positions by removing a precut in the yellow control piece.			
Black	ON_PB, ON_M, OL40	ONZ20B	
Red-yellow	ON_PB, ON_M, OL40	ONZ20RY	
<b>Round padlockable handle for screw mounting on door</b> For max 3 padlocks with max 8 mm hasp diameter. Locking positions of type ONZ33_ 9 o'clock (O, OFF) - 12 o'clock (1, ON) or switch rotated 12 o'clock (O, OFF) - 3 o'clock (1, ON). Other square handle padlock positions can be specified by camweb tool.			
<b>Size 64x64, shaft size 6 mm</b>			
Black	ON_PB, OL40	ONZ331PB	
Red-yellow	ON_PB, OL40	ONZ331PRY	
<b>Size 90x90, shaft size 8 mm</b>			
Black	OL80, OL125, OL160	OLZ332RB	
Red-yellow	OL80, OL125, OL160	OLZ332RRY	

1) More cam switches with padlockable handles can be configured on Internet by the Canweb configurator tool.



# CamLine

## Accessories

### Ordering details

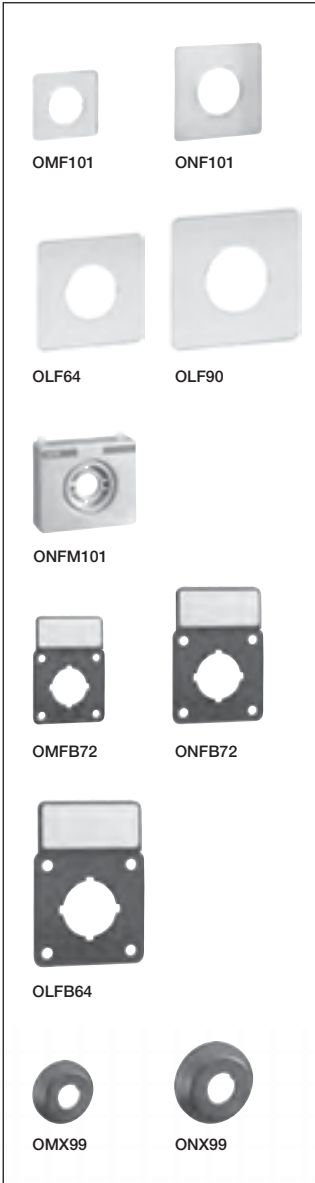

### Front plates

Colour	For cam switches/handle size	Catalogue number	List price
<b>Front plates, without engraving</b>			
<i>Size 30x30</i>			
Silver	OM/OMP_1	OMF101	
Yellow	OM/OMPR41	OMFY101	
<i>Size 48x48</i>			
Silver	ON_PB, OL 40/ONP_1	ONF101	
Clear	ON_PB, OL 40/ONP_1	ONFC101	
Yellow	ON_PB, OL 40/ONPRY1	ONFY101	
<i>Size 64x64</i>			
Silver	ONPL_1	OLF64	
Clear	ONPL_1	OLFC64	
Yellow	ONPLRY1	OLFY64	
Black	ONPL_1	OLFB64	
<i>Size 90x90</i>			
Silver	OL80, OL125, OL160/OLR2_	OLF90	
Clear	OL80, OL125, OL160/OLR2_	OLFC90	
Yellow	OL80, OL125, OL160/OLR2_	OLFY90	
<i>Size 130x130</i>			
Silver	OL200/OLR3_	OLF130	
Clear	OL200/OLR3_	OLFC130	
Yellow	OL200/OLR3_	OLFY130	
<i>Size H=45mm, W=54mm</i>			
Grey	ON_M	ONFM101	

### Additional lettering plates

Without engraving, black engraving from front side available.

<i>Size 30x30</i>			
Black frame	OM	OMFB72	
Grey frame	OM	OMFG72	
<i>Size 48x48</i>			
Black frame	ON_PB, OL 40	ONFB72	
Grey frame	ON_PB, OL 40	ONFG72	
<i>Size 64x64</i>			
Black frame	ON_PB, OL 40	OLFB64	
Grey frame	ON_PB, OL 40	OLFG64	

### Front ring

Black	OM	OMX99	
Black	ON_PB, OL40	ONX99	

### Shaft sealing

To prevent dust and moisture from penetrating along the switch shaft. Protection to NEMA 4X from the front. Door drilling 16...17 mm.

Description	For cam switches/handle size	Catalogue number	List price
Shaft Seal	ON, OL40	ONZ11	
	OL 80...160	OLZ12	

### Door clutch

This is for coupling base-mounted unit in an enclosure with it's control handle mounted on a pivoting door.

Description	For cam switches	Catalogue number	List price
Door clutch	ON, OL40	ONZ45P	
	OL 80...160	OLZ652	
	OL200	OLZ653	



# CamLine

## Accessories

### Ordering details



OMK95      ONK95



ONZ10L\_



OMNX80



ONX30



ONZ74\_

### Other accessories

#### Spare key

Number of keys included	For cam switches	Catalogue number	List price
2 pcs	OM	OMK95	
3 pcs	ON, OL40	ONK95	

#### Protective rear cover

Transparent, IP 42 protection

Number of chambers	Number of contacts	For cam switches	Catalogue number	List price
1-2	1-4	ON	ONZ10L2	
3-4	5-8	ON	ONZ10L4	
5-6	9-12	ON	ONZ10L6	
2	1-4	OL40	OLZ401L2	
4	5-8	OL40	OLZ401L4	
6	9-12	OL40	OLZ401L6	
2	1-4	OL80...160	OLZ1601L2	
4	5-8	OL80...160	OLZ1601L4	
6	9-12	OL80...160	OLZ1601L6	

#### Nut spanner

for mounting the handle to the door

Colour	For cam switches	Catalogue number	List price
Black	OM, ON	OMNX80	

#### Adaptor ring

for fixing the snap-on handles in the 30 mm door drilling.

Black	ON	ONX30	
-------	----	-------	--

#### Base mounting kit

Includes base for DIN-rail mounting, shaft adaptor and 200 mm shaft for cutting up to 250 mm panel depth.

Depth [mm]	For cam switches	Catalogue number	List price
250	ON	ONZ74	

#### DIN-Rail mounting plate

Depth [mm]	For cam switches	Catalogue number	List price
Includes base for DIN-rail mounting	ON	ONZ37	



# CamLine

## Rotary cam switches

### Dimension drawings, OM and ON

#### OM

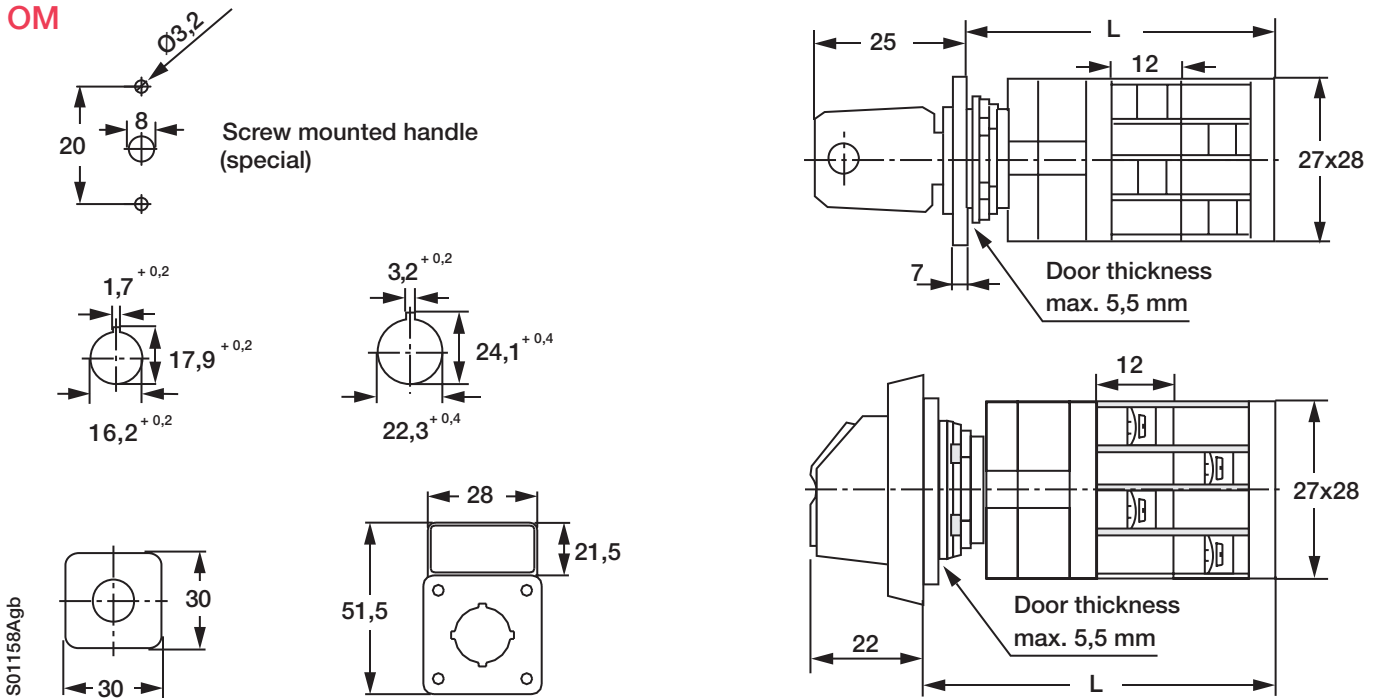

		Number of contact chambers							
		1	2	3	4	5	6	7	8
Snap-on mounting (P type)	L	45	57	69	81	90	105	117	129
Screw mounting (R type)	L	33	45	57	69	81	93	105	117

#### ON

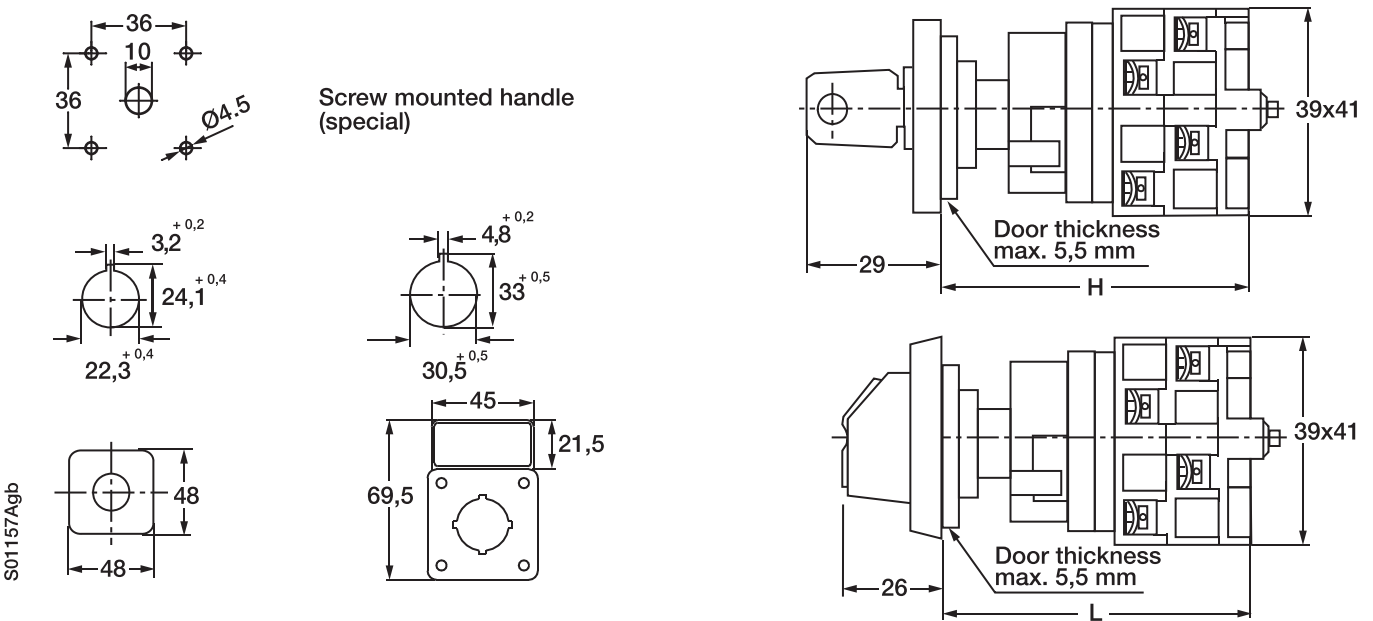

		Number of contact chambers									
		1	2	3	4	5	6	7	8	9	10
Snap-on mounting (P type)	L	54	66	78	90	102	114	126	138	150	162
Screw mounting (R type)	L	34	46	58	70	82	94	106	118	130	142
	H	62	74	86	98	110	122	134	146	159	171



# CamLine

## Rotary cam switches

### Dimension drawings, ON, OL and ONZ 74

#### ON\_M

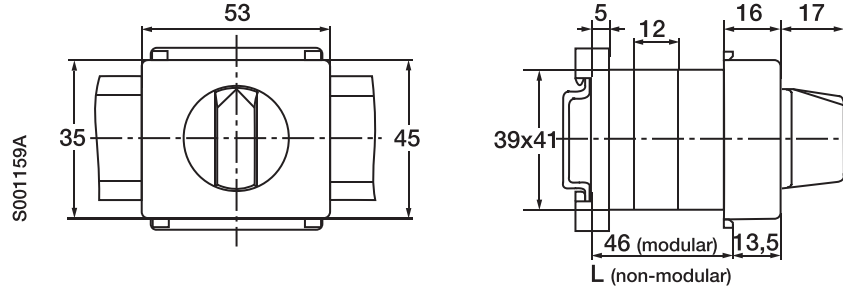

Non-modular: number of contact chambers							
	2	3	4	5	6	7	8
L	58	70	82	94	106	118	130

#### ON with base mounting kit ONZ 74 - to be specified by Camweb configurator

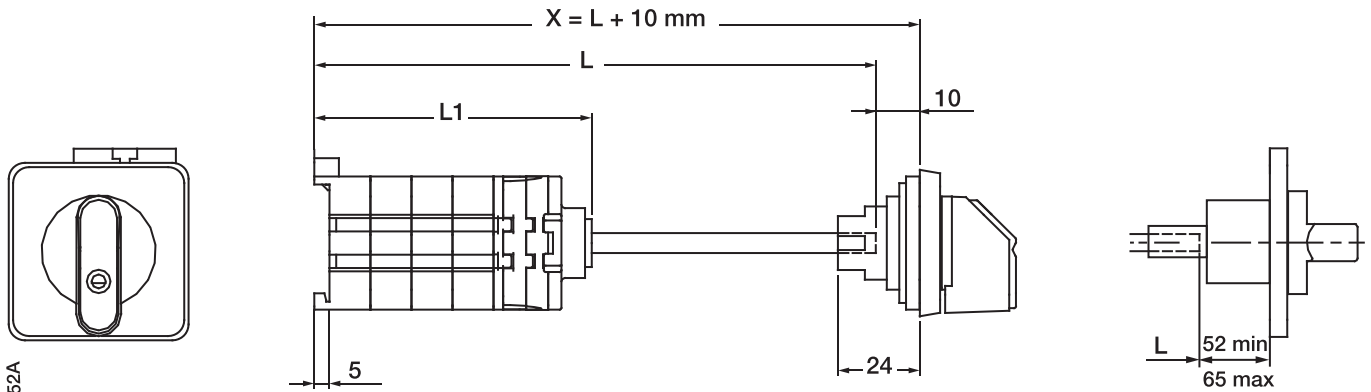

Number of contact chambers/example: Shaft length 200 mm										
	1	2	3	4	5	6	7	8	9	10
L <sub>1</sub>	55	67	79	91	103	115	127	139	151	163
L	345	357	369	381	393	405	417	429	441	453

#### OL40, door mounted with snap-on mounting handle

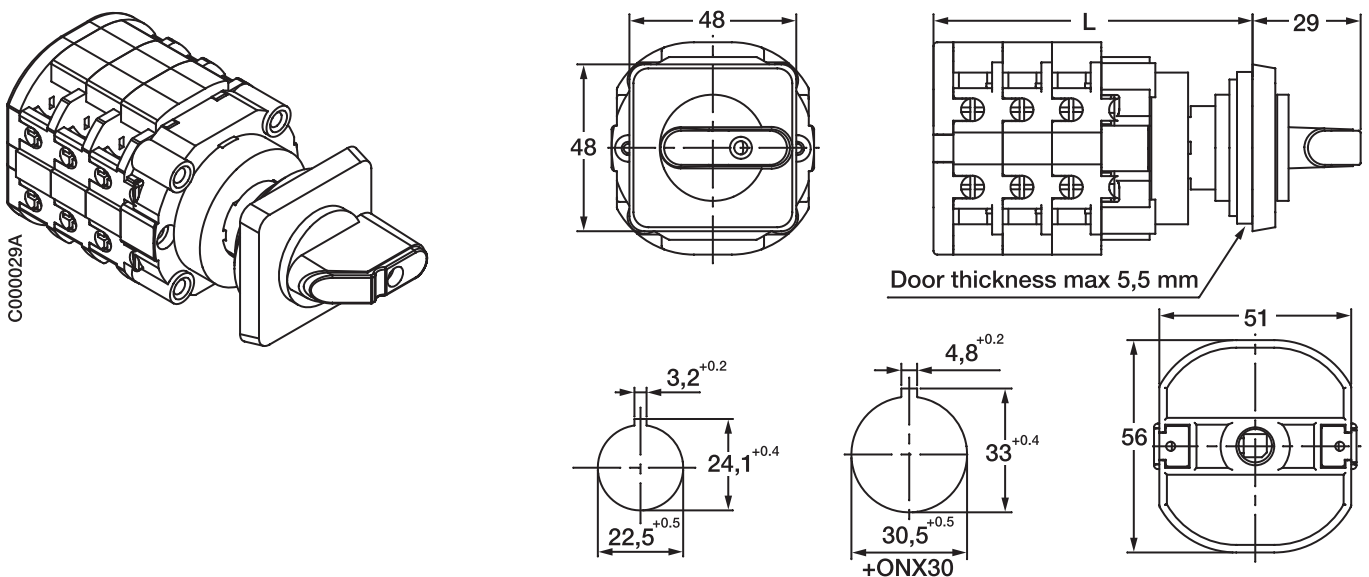

Number of contact chambers										
	1	2	3	4	5	6	7	8	9	10
L	59	72	85	98	111	124	137	150	163	176





# CamLine

## Rotary cam switches

### Dimension drawings, OL40

#### OL40, door mounted with screw mounting handle, front plate size 64x64

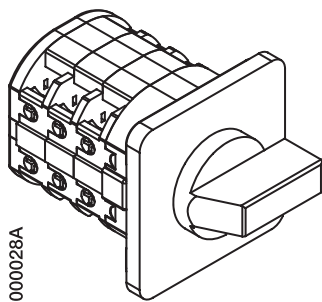

C000028A

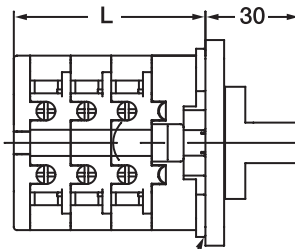
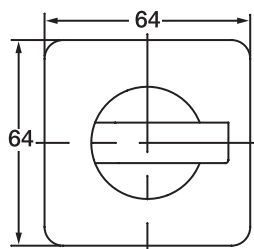

Door thickness max 5,5 mm

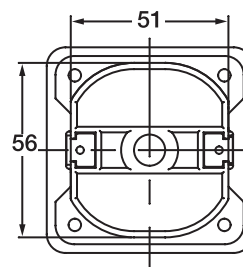
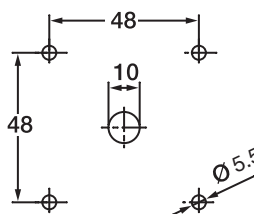

	Number of contact chambers									
	1	2	3	4	5	6	7	8	9	10
L	39	52	65	78	91	104	117	130	143	156



# CamLine

## Rotary cam switches

### Dimension drawings, OL40

**OL40, base mounted, front plate size 48x48 - to be specified by Camweb configurator**

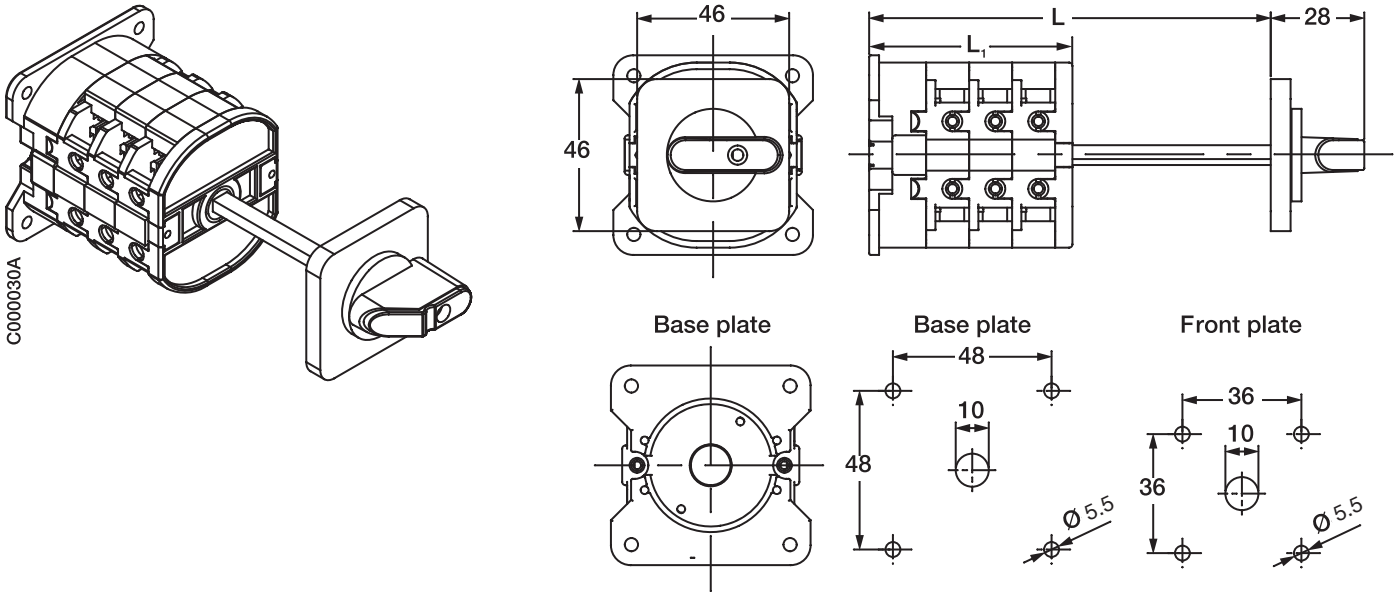

Number of contact chambers/example: shaft length 200 mm										
	1	2	3	4	5	6	7	8	9	10
L <sub>1</sub>	37	49	62	75	88	101	114	127	140	153
L	237	249	262	275	288	301	314	327	340	353

**OL40, base mounted, front plate size 64x64 - to be specified by Camweb configurator**

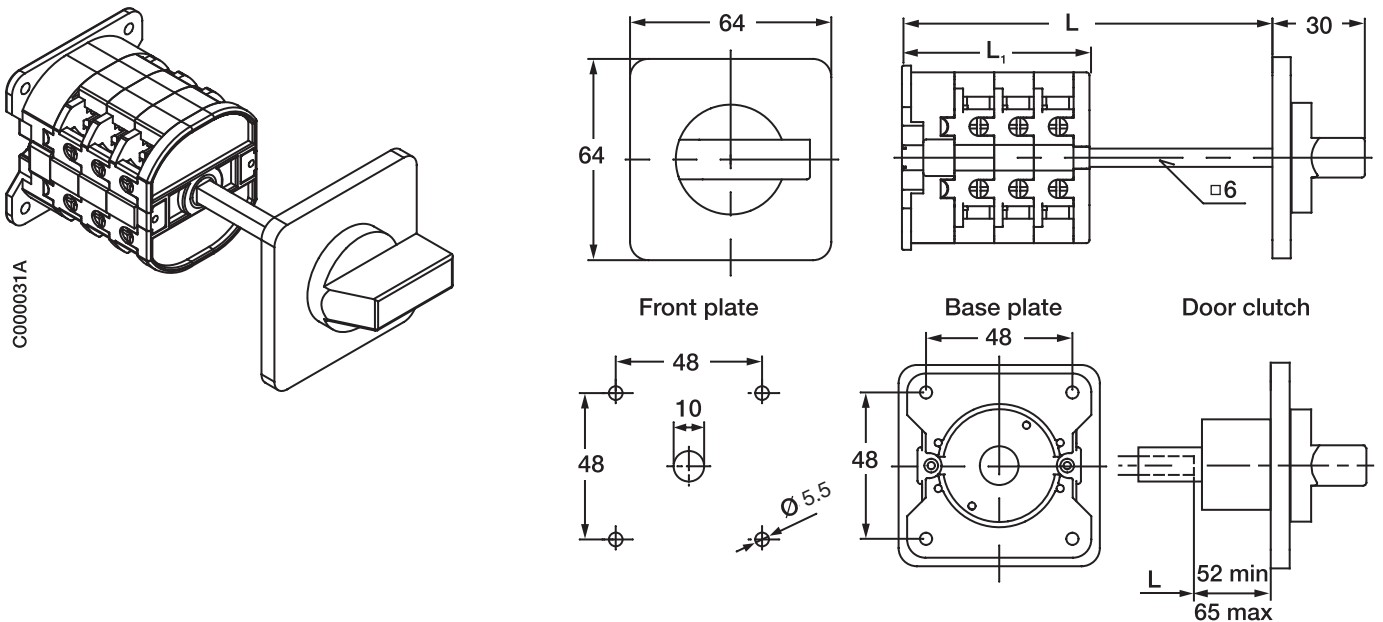

Number of contact chambers/example: shaft length 200 mm										
	1	2	3	4	5	6	7	8	9	10
L <sub>1</sub>	37	49	62	75	88	101	114	127	140	153
L	237	249	262	275	288	301	314	327	340	353



# CamLine

## Rotary cam switches

### Dimension drawings, OL80, OL125 and OL160

#### OL80, OL125, OL160 door mounted

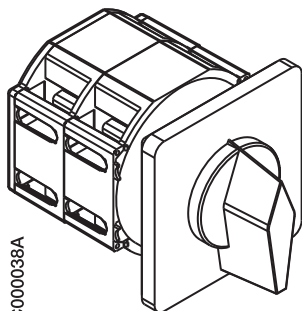

C000038A

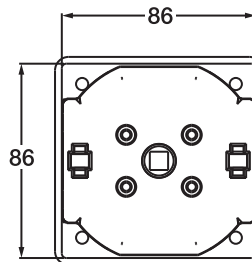
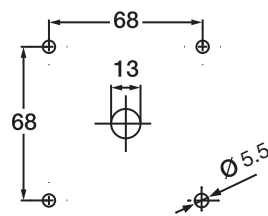
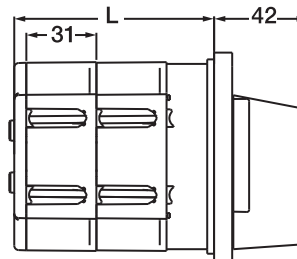
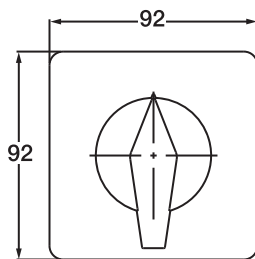

	Number of contact chambers									
	1	2	3	4	5	6	7	8	9	10
L	66	97	128	159	190	221	252	283	314	345

#### OL80, OL125, OL160 door mounted, lug terminals - to be specified by Camweb configurator

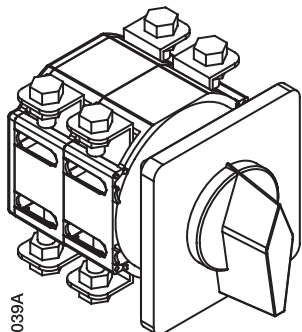

C000039A

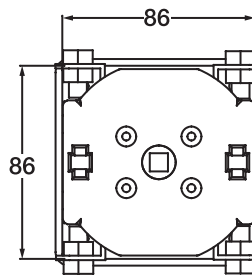
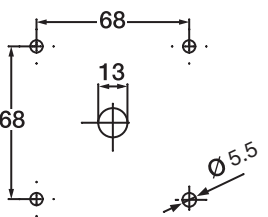
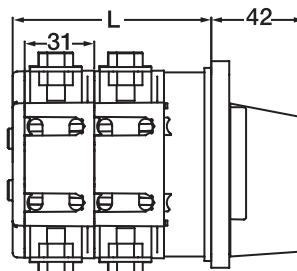
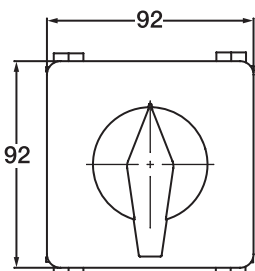

	Number of contact chambers									
	1	2	3	4	5	6	7	8	9	10
L	66	97	128	159	190	221	252	283	314	345



# CamLine

## Rotary cam switches

### Dimension drawings, OL80, OL125 and OL160

#### OL80, OL125, OL160 base mounted - to be specified by Camweb configurator

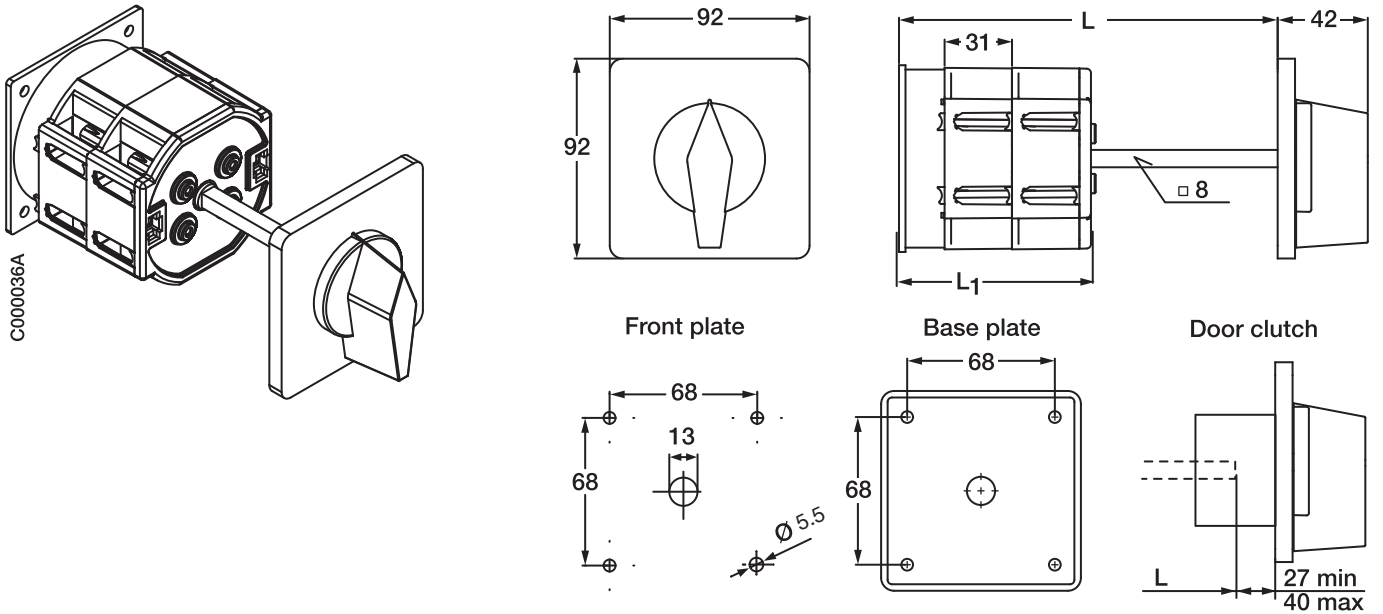

	Number of contact chambers/Shaft length 100 mm									
	1	2	3	4	5	6	7	8	9	10
L <sub>1</sub>	65	96	127	158	189	220	251	282	313	344
L	165	196	227	258	289	320	351	382	413	444

#### OL80, OL125, OL160 base mounted, lug terminals - to be specified by Camweb configurator

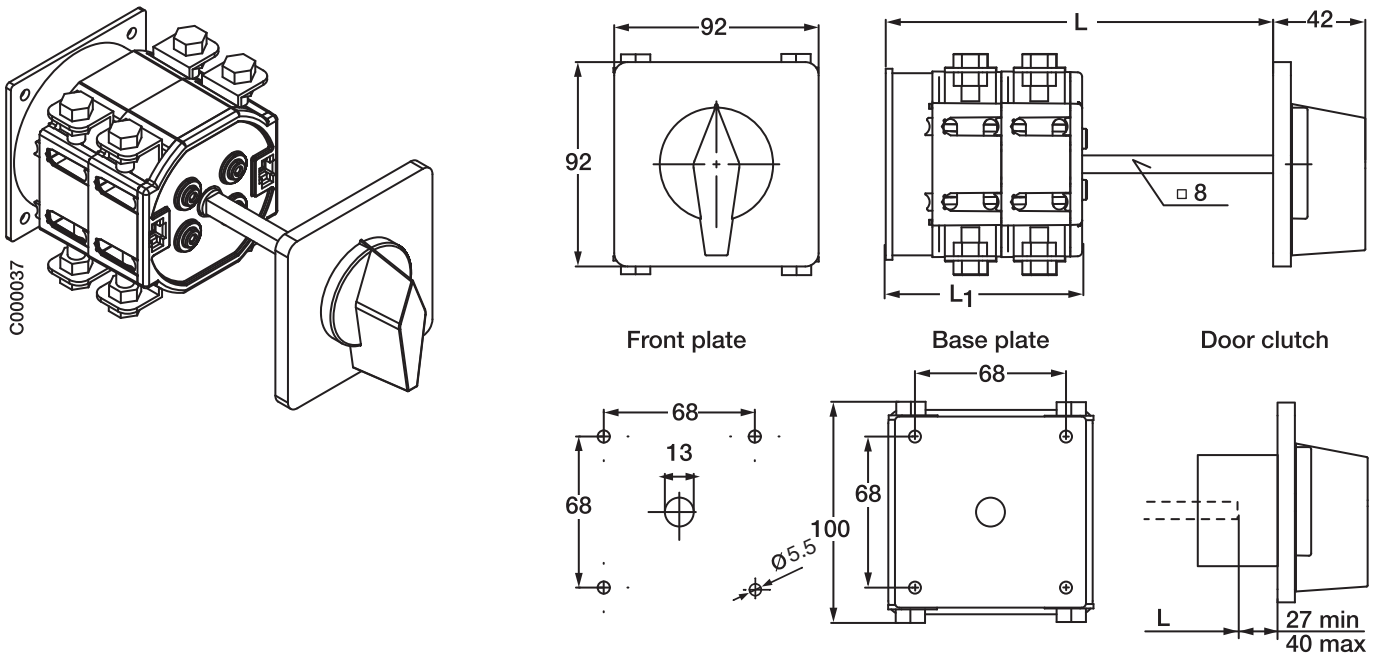

	Number of contact chambers/Shaft length 100 mm									
	1	2	3	4	5	6	7	8	9	10
L <sub>1</sub>	65	96	127	158	189	220	251	282	313	344
L	165	196	227	258	289	320	351	382	413	444



# CamLine

## Rotary cam switches

### Dimension drawings, OL200

#### OL200 door mounted

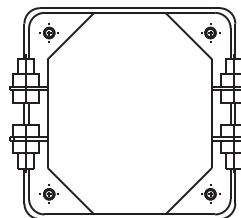
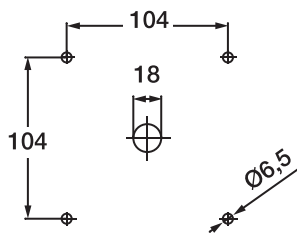
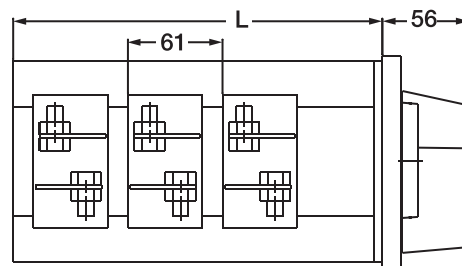
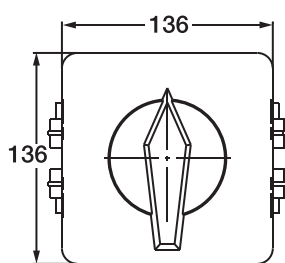
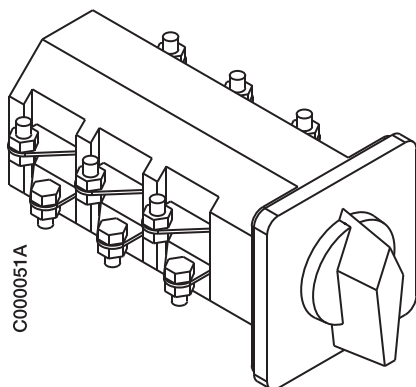

L	Number of contact chambers									
	1	2	3	4	5	6	7	8	9	10
L	120	181	242	303	364	425	486	547	608	669

#### OL200 base mounted - to be specified by Camweb configurator

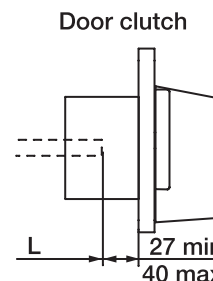
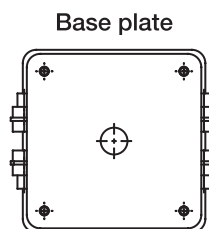
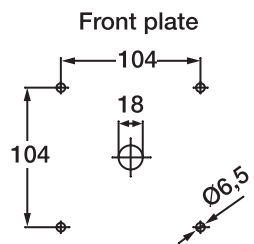
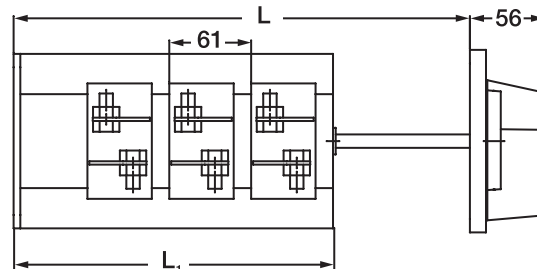
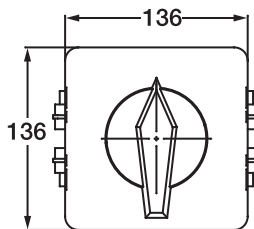
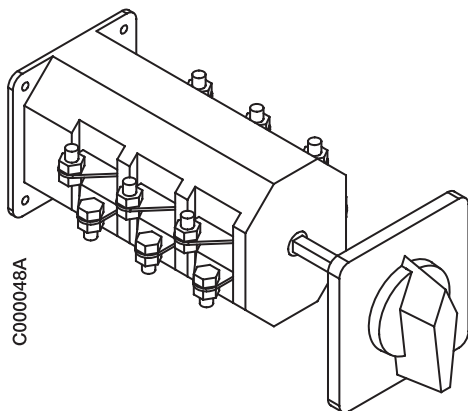

L	Number of contact chambers/example: Shaft length 100 mm									
	1	2	3	4	5	6	7	8	9	10
L <sub>1</sub>	120	181	242	303	364	425	486	547	608	669
L	220	281	342	403	464	525	586	647	708	769



# CamLine

## Rotary cam switches

### Dimension drawings, front plates

#### Front plates, sizes and door drillings

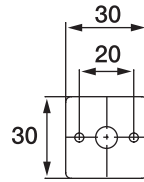

Size 30x30  
OM

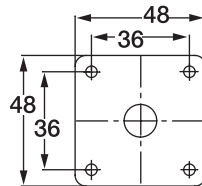

Size 48x48  
ON

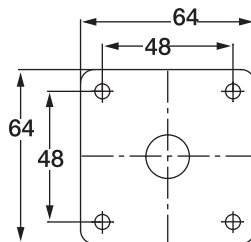

Size 64x64  
ON  
OL 40

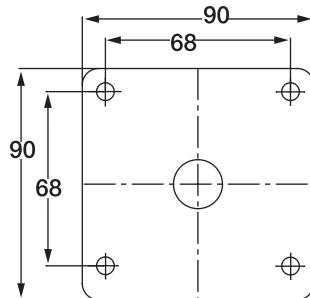

Size 90x90  
OL 80...160

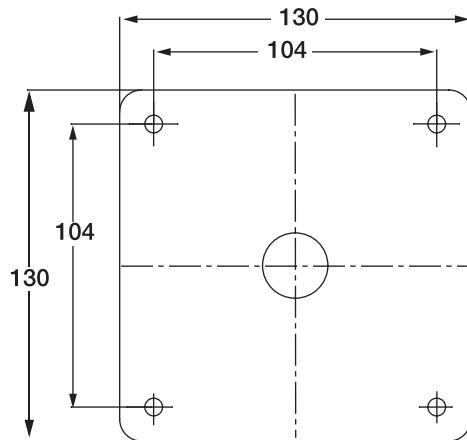

Size 130x130  
OL 200

C000033



# CamLine

## Rotary cam switches

### Dimension drawings, handles

#### Snap-on handle for OM, type OMP\_

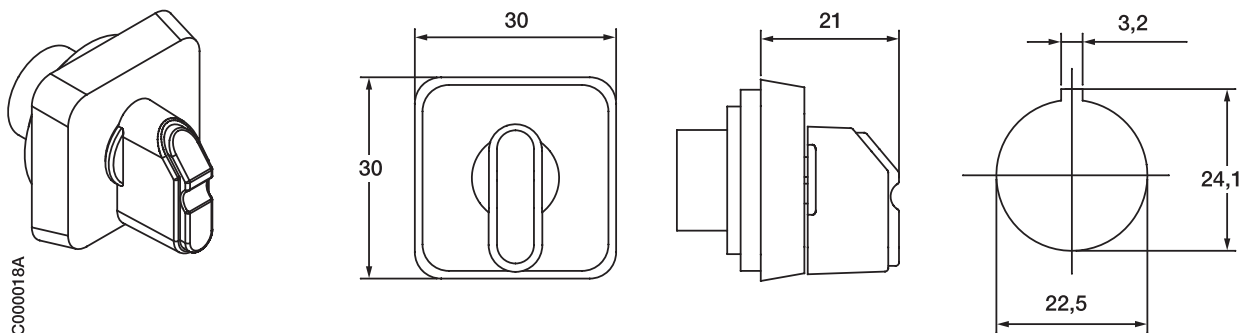

#### Snap-on key operated handle for OM - to be specified by Camweb configurator

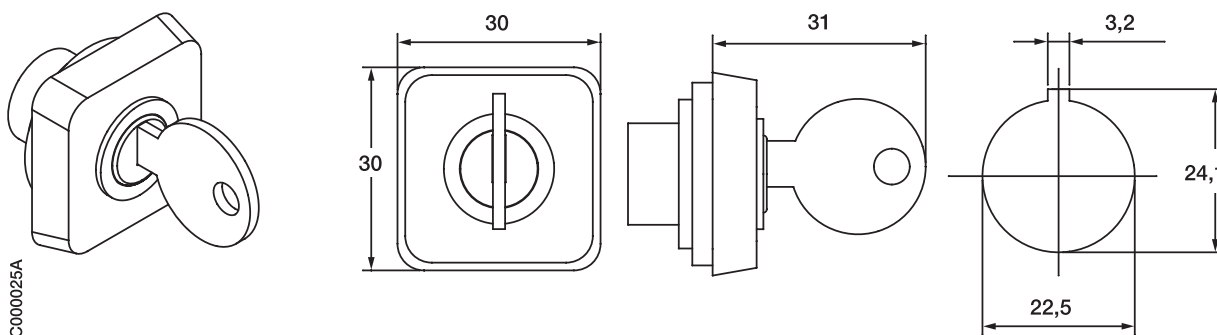

#### Screw mounted handle ON and OL40 - to be specified by Camweb configurator

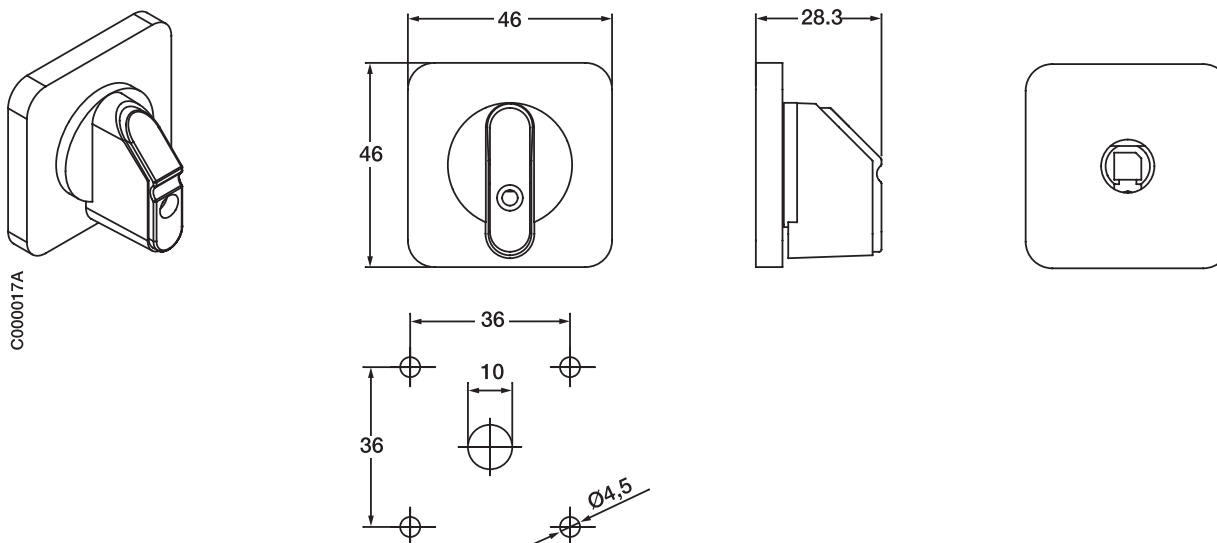



# CamLine

## Rotary cam switches

### Dimension drawings, handles

#### Snap-on key operated handle for ON - to be specified by Camweb configurator

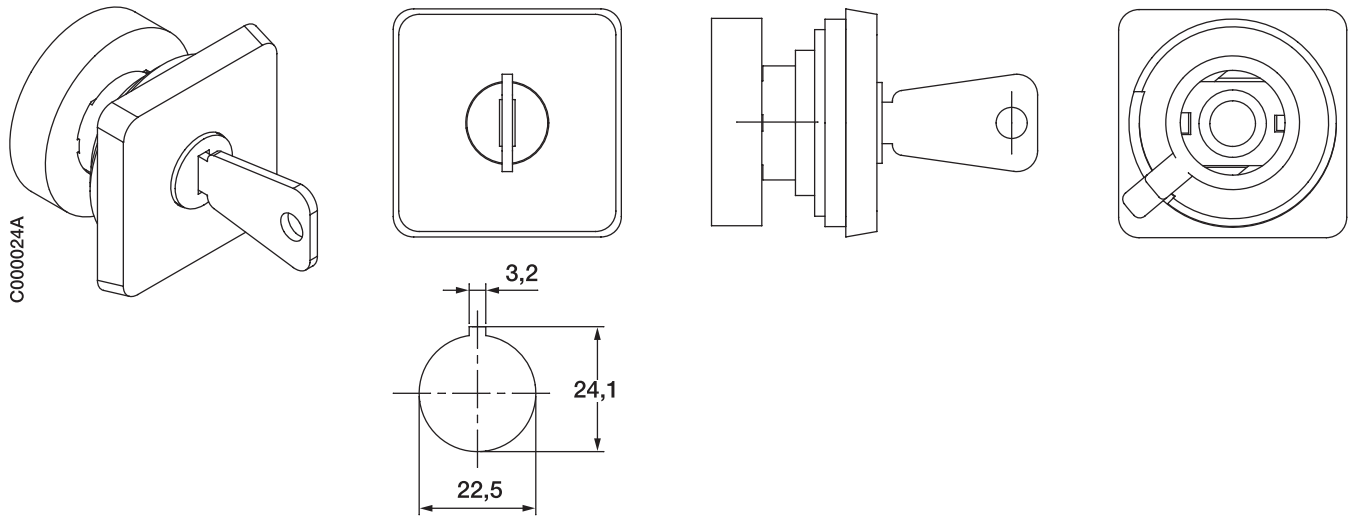

#### Screw mounted large handle option for ON and OL40 - to be specified by Camweb configurator

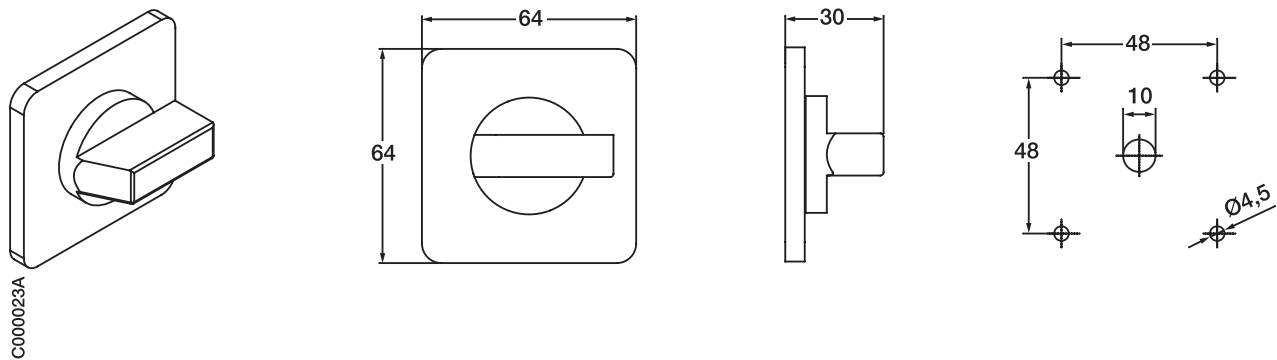

#### Padlockable handle knob for ON and OL40, type ONZ20\_ (also suitable for 64x64 handle)

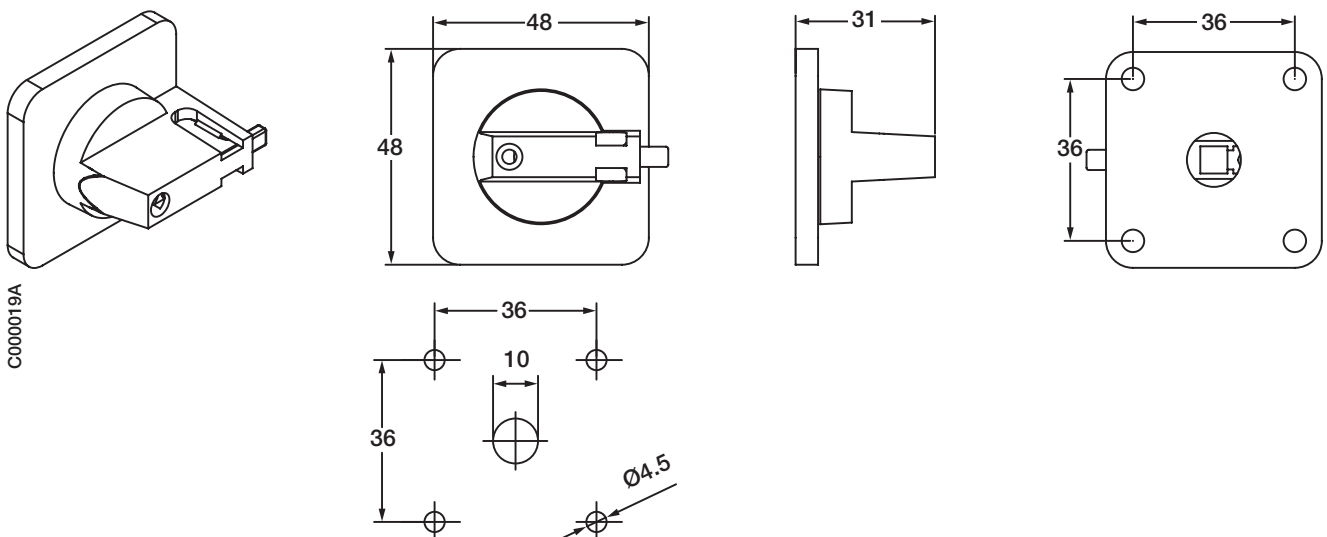





# CamLine

## Rotary cam switches

### Dimension drawings, handles

#### Round padlockable snap-on mounted handle for ON and OL40 - to be specified by Camweb configurator (Type P3)

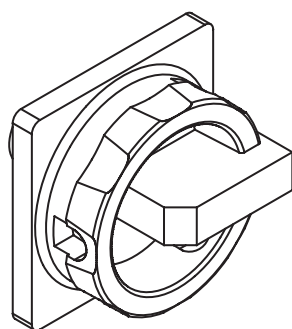

C000049A

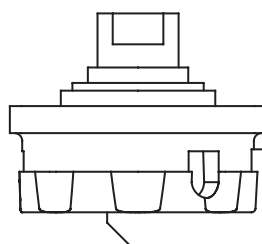
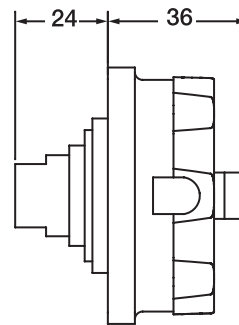
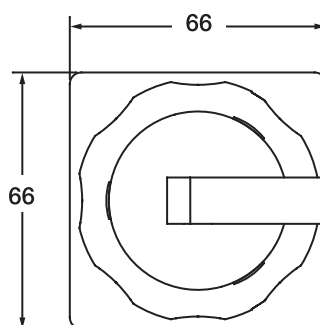

Shaft size 6mm

#### Round padlockable screw mounted handle for ON and OL40, type ONZ331P\_ (Type R3)

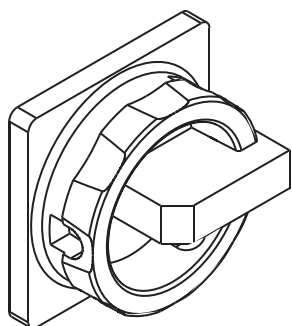

C000022A

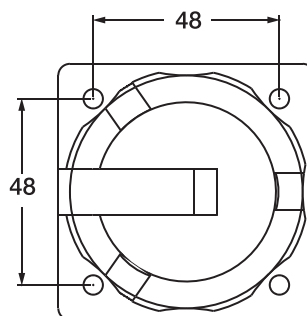
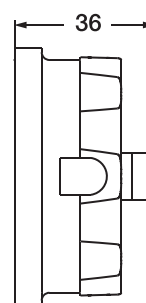
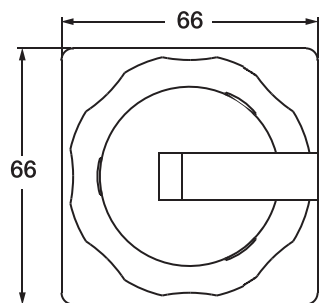

Shaft size 6 mm



# CamLine

Rotary cam switches  
Dimension drawings, handles

## Round padlockable snap-on mounted handle for OL80, OL125 and OL160 - to be specified by Camweb configurator (Type P3)

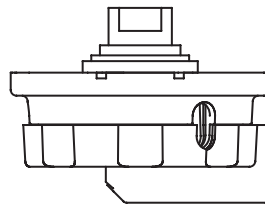
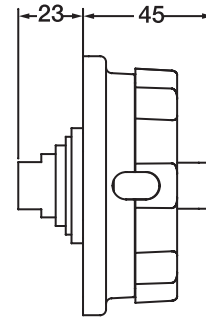
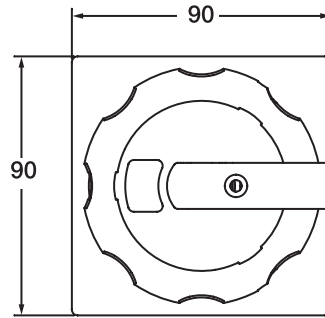
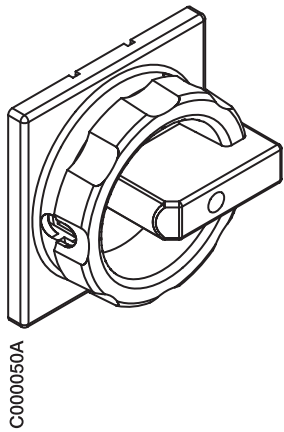

## Round padlockable screw mounted handle for OL80, OL125 and OL160, type OLZ332R\_ - Type R3 to be specified by the Camweb configurator

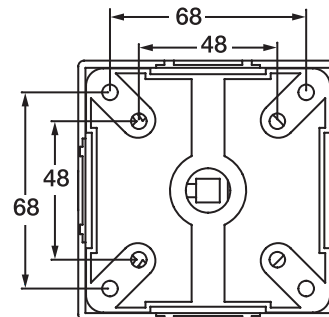
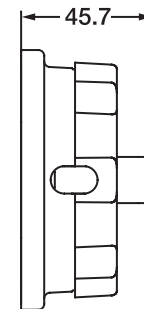
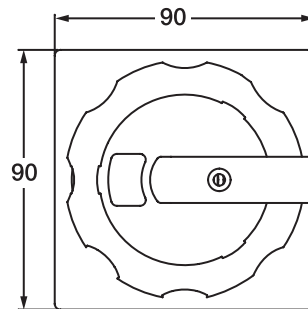
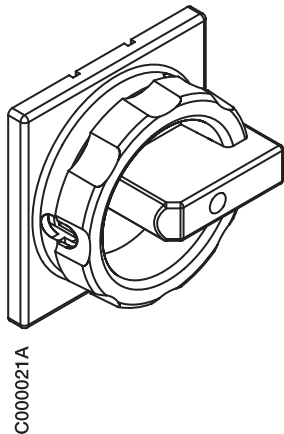

Shaft size 8 mm



# CamLine

## Rotary cam switches

### Dimension drawings, handles

**Square padlockable handle for ON and OL40 -**  
to be specified by Camweb configurator (type R5)

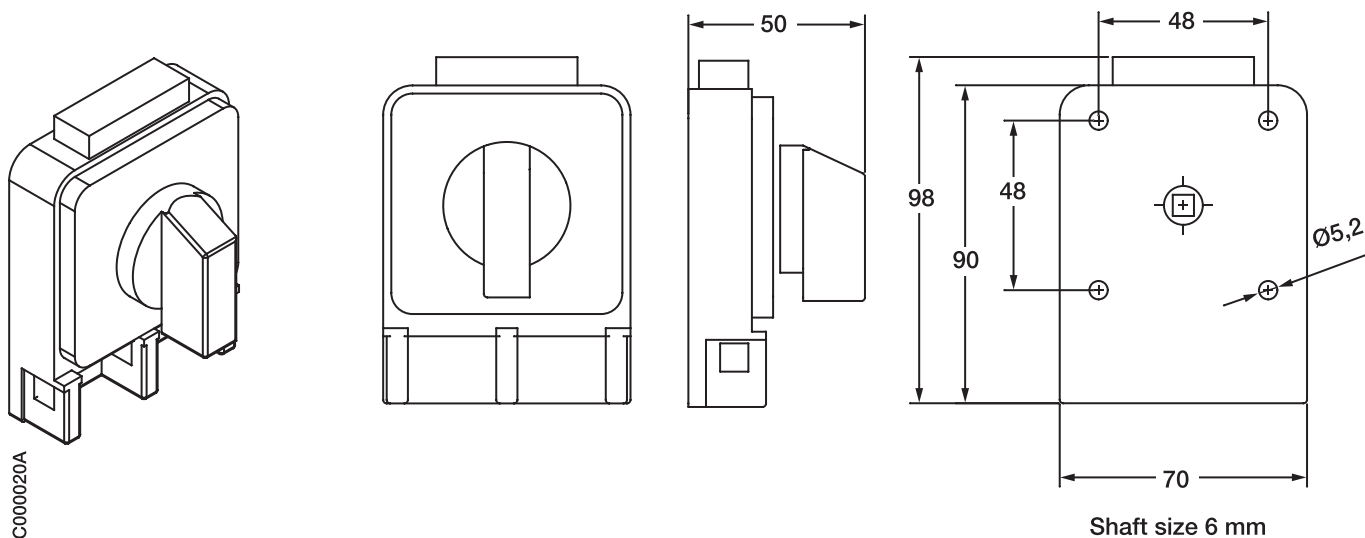

**Square padlockable handle for OL80, OL125 and OL160**  
- to be specified by Camweb configurator (Type R5)

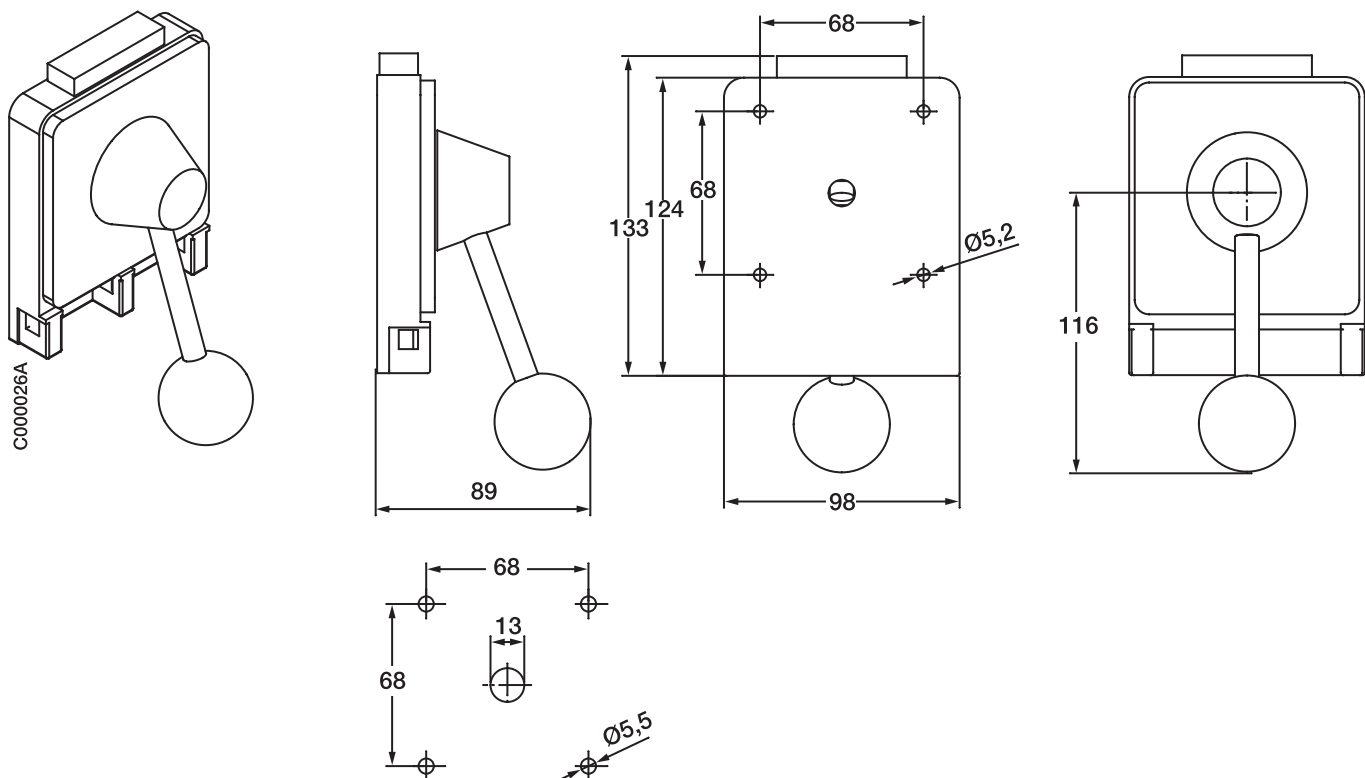



# CamLine

Rotary cam switches  
Dimension drawings, handles

**Key interlocked handle for ON and OL40, front plate size 48x48**  
- to be specified by Camweb configurator (Type Q)

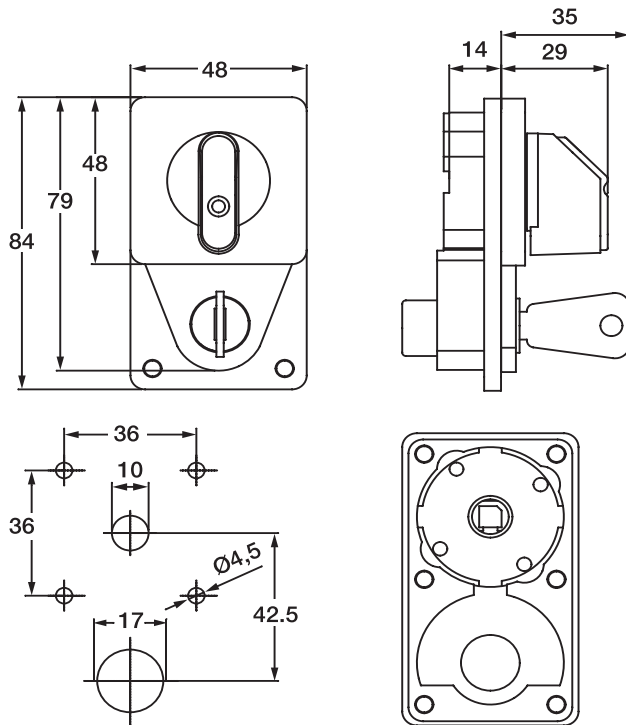
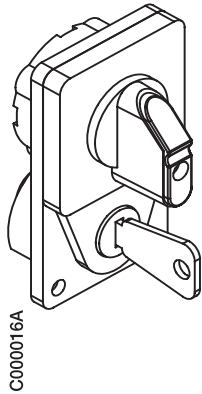

**Key interlocked handle for ON and OL40, front plate size 64x64**  
- to be specified by Camweb configurator (Type Q)

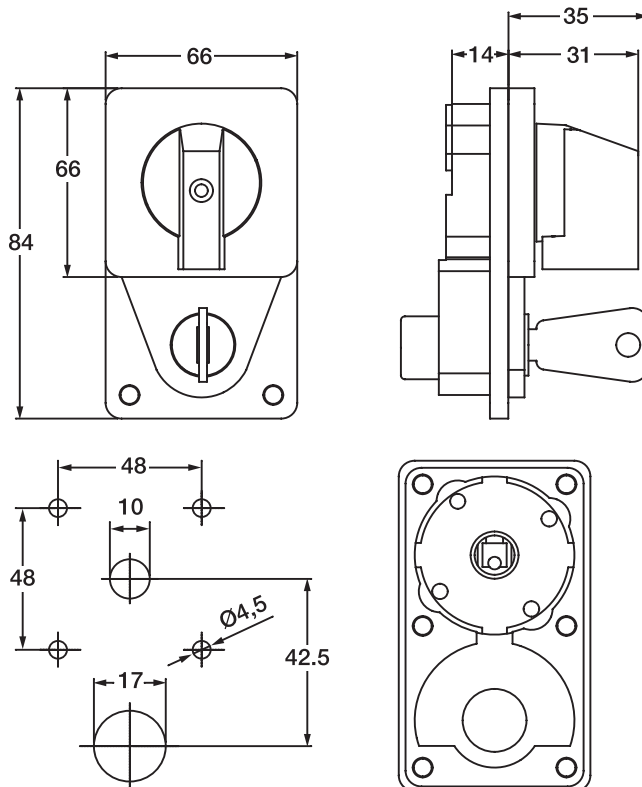
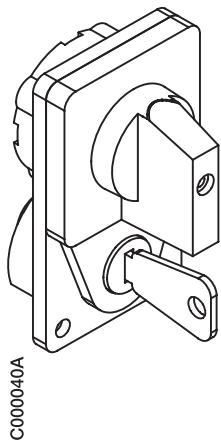



# CamLine

## Rotary cam switches

### Dimension drawings and handles

**Push button interlock handle for ON and OL40 -**  
to be specified by Camweb configurator (Type U)

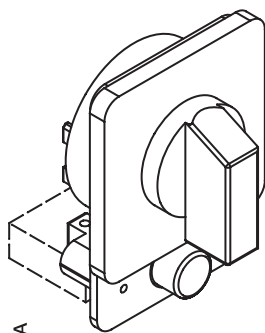

C000015A

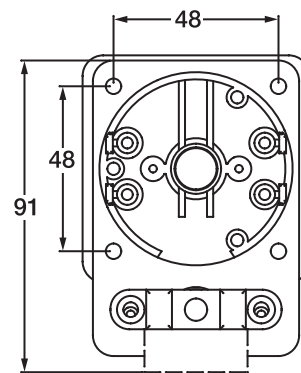
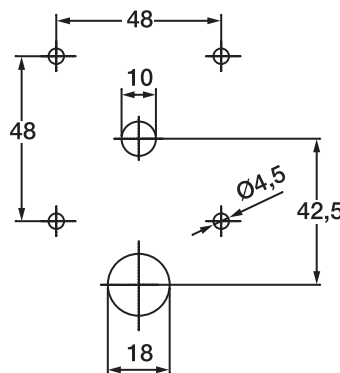
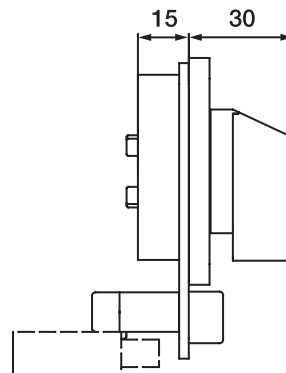
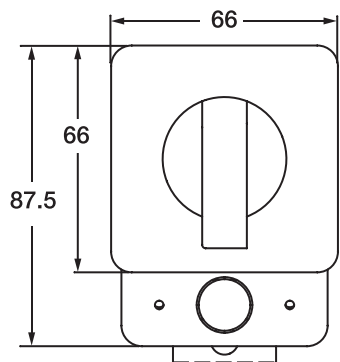

### Pistol and double lever handles

OLZ2R\_, OLZ2R

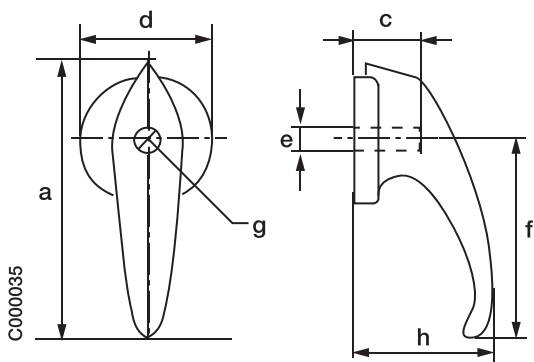

C000035

OLZ3D\_

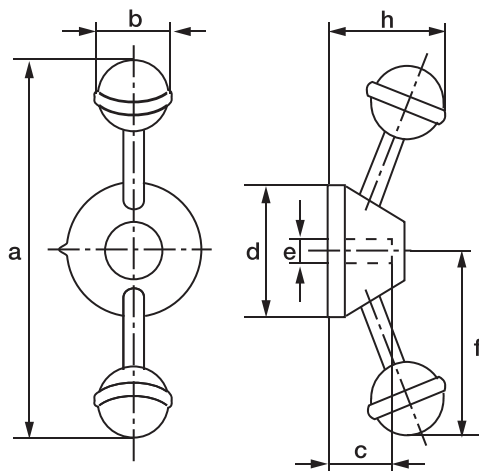

	a	b	c	d	e	f	g	h	y
OLZ2R_	112	40	21	50	8 <sup>□</sup>	80	114	50	9
OLZ3R_	141	54	26	77	10 <sup>□</sup>	145	145	66	14
OLZ3D_	252	40	28	77	10 <sup>□</sup>	126	-	56	10



# CamLine

## Rotary cam switches

### Dimension drawings, door clutch

#### Door clutch, interlock for hinged door, for ON and OL40 (ONZ45P)

- to be specified by Camweb configurator

- to lock the panel when the switch is in the ON position

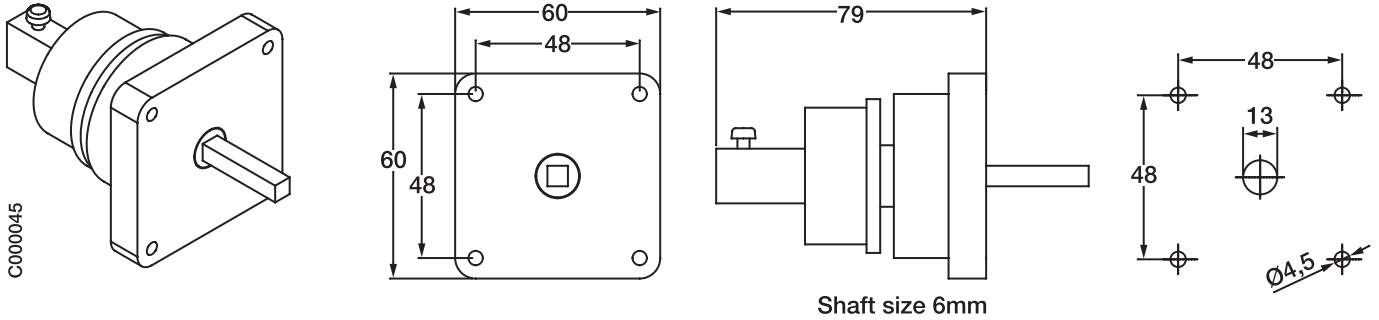

#### Door clutch, interlock for hinged door, for OL40 (ONZ45P) - to be specified by Camweb configurator

- to lock the panel when the switch is in the ON position

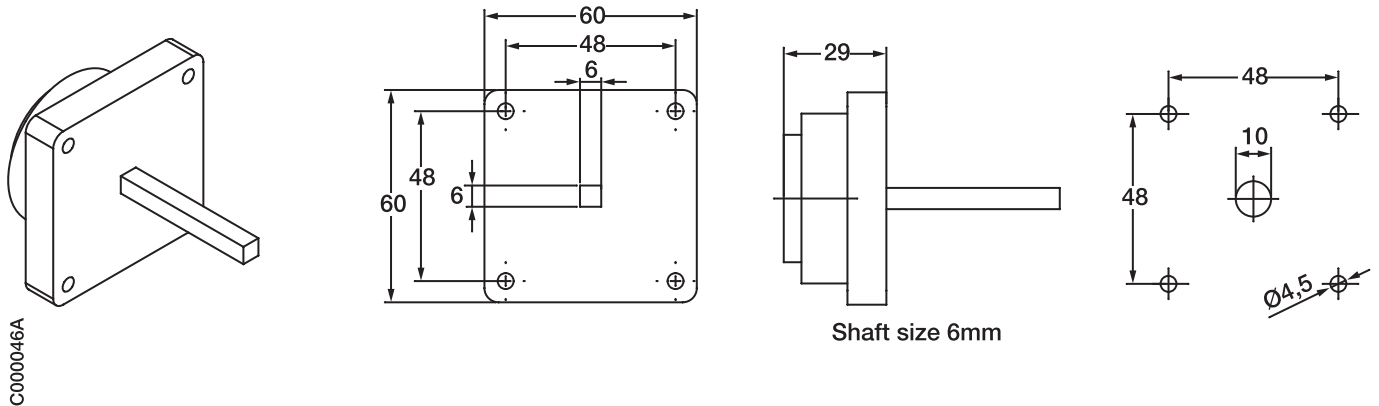

#### Door clutch, interlock for hinged door, for OL80, OL125, OL160 (OLZ652) and OL200 (OLZ653)

- to be specified by Camweb configurator

- to lock the panel when the switch is in the ON position

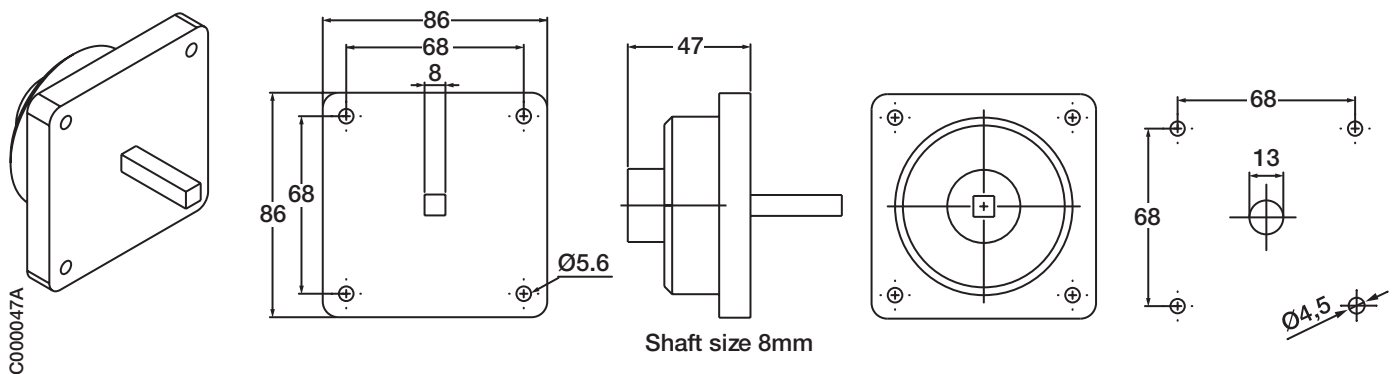



# CamLine

## Rotary cam switches

### Dimension drawings, double gang

#### Double gang (Tandem) drive for ON, standard handle

- to be specified by Camweb configurator

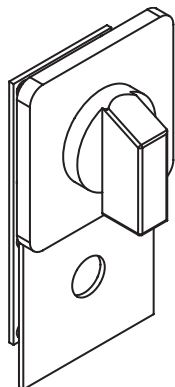

C000041A

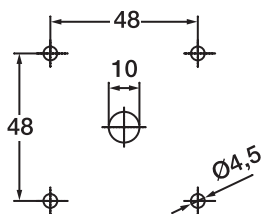
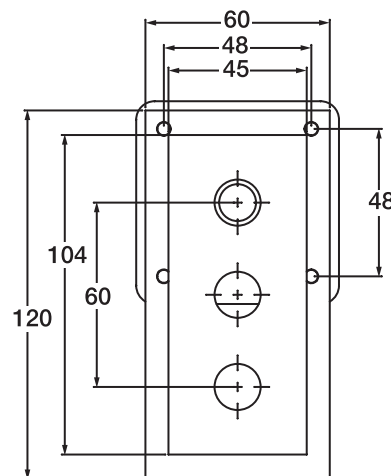
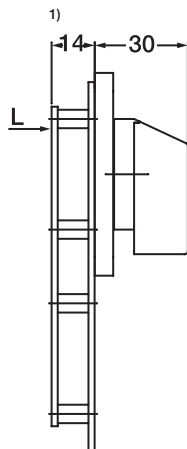
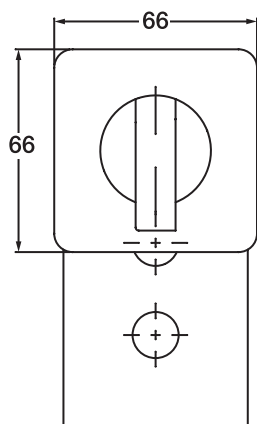

#### Double gang (Tandem) drive for OL40, standard handle

- to be specified by Camweb configurator

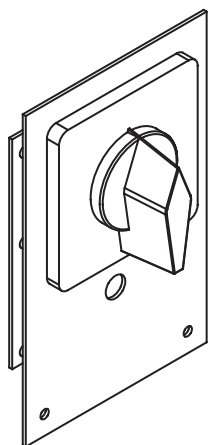

C000042A

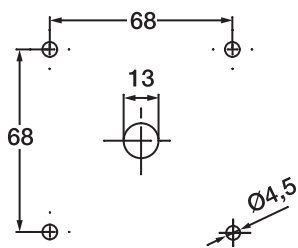
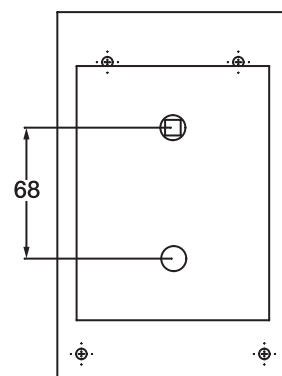
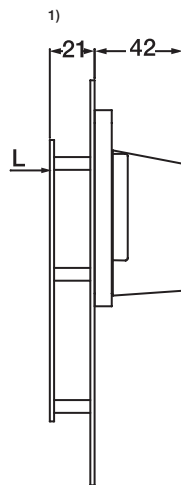
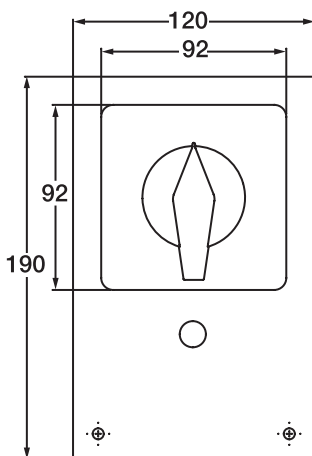

<sup>1)</sup> Add the dimension L of the screw mounted cam switch for the total depth.



# CamLine

## Rotary cam switches

### Dimension drawings, triple gang

**Triple gang drive for ON, standard handle - to be specified by Camweb configurator**

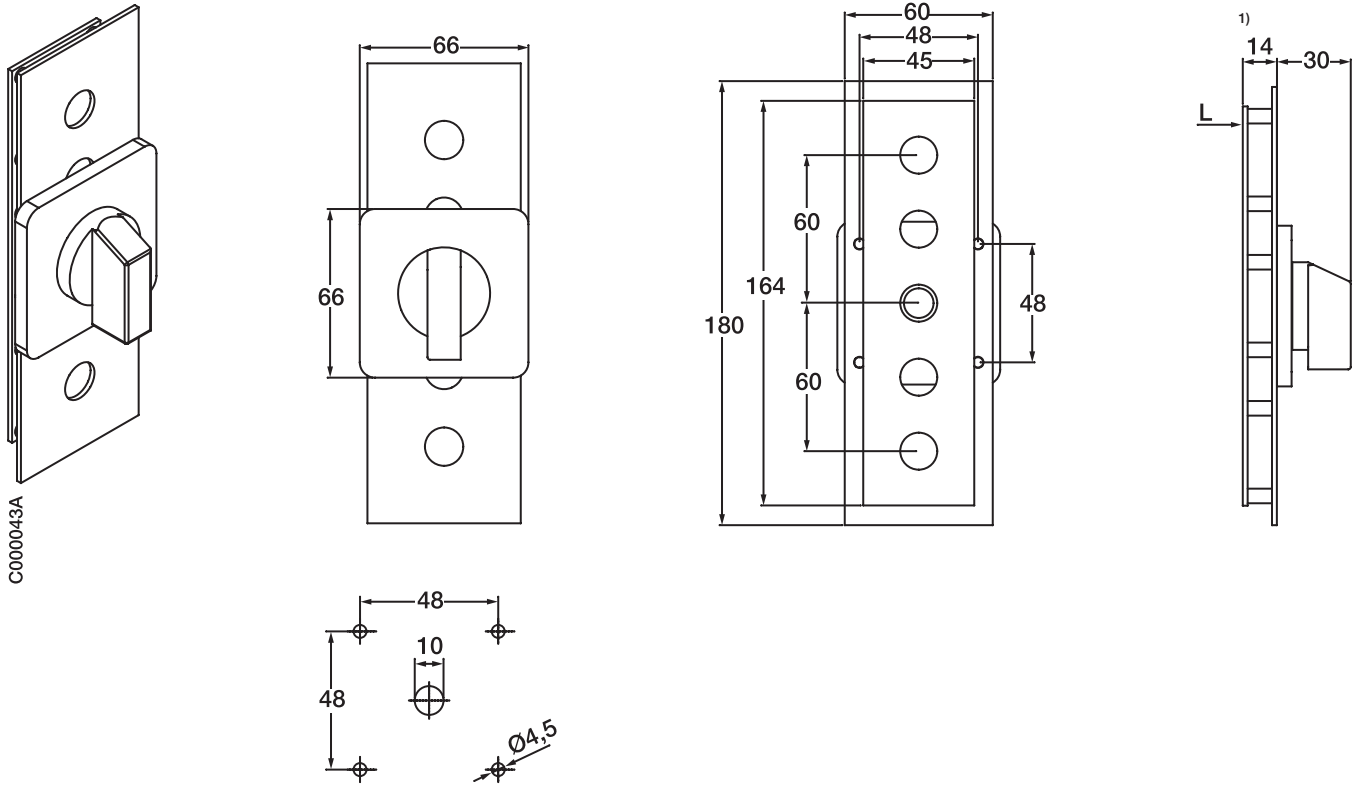

**Triple gang drive for OL40, standard handle - to be specified by cam web configurator**

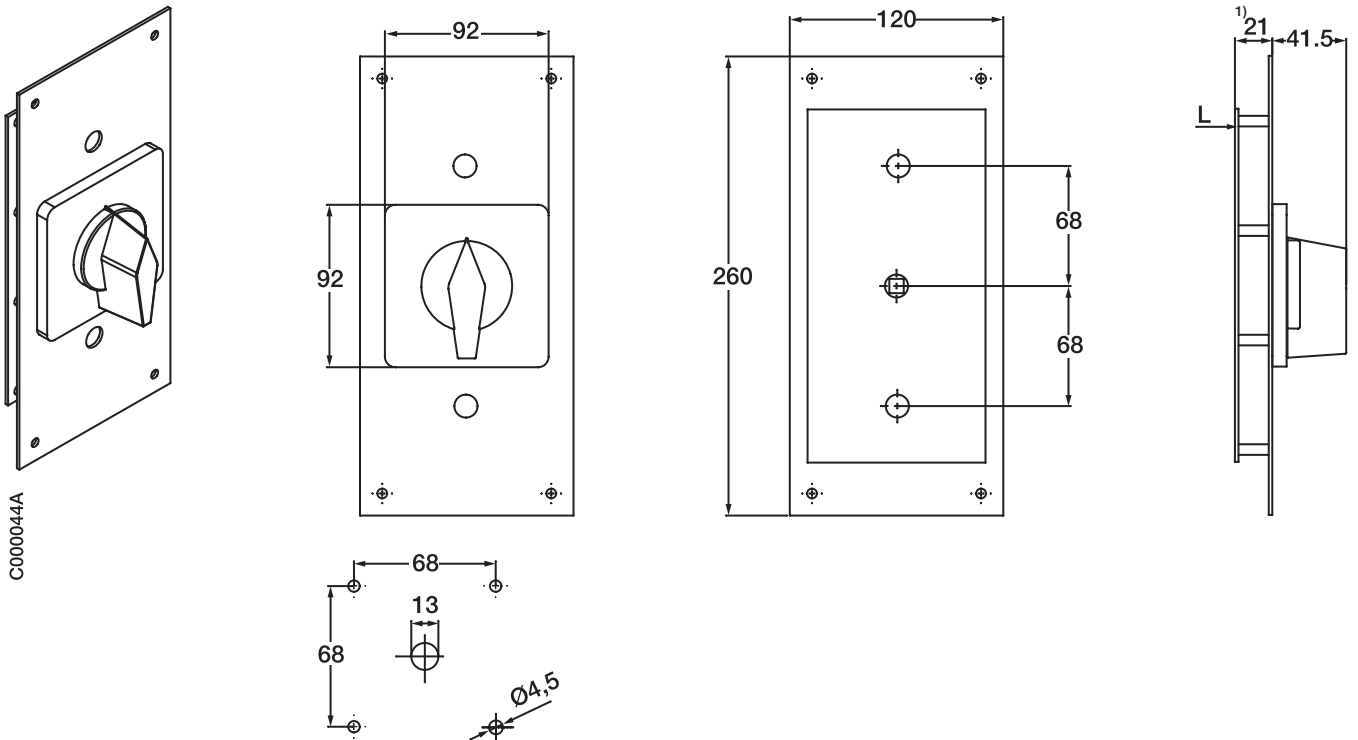

<sup>1)</sup> Add the dimension L of the screw mounted cam switch for the total depth.





# CamLine Enclosed rotary cam and main switches

## Contents:

### Enclosed rotary cam and main switches

#### Ordering information

Enclosed cam switches.....	56
Enclosed main switches.....	56
Enclosures.....	56
Disconnect switches for enclosures OTC_.....	57
Base mounted disconnect switches .....	57
Door mounted disconnect switches .....	57
Accessories .....	57
Dimension drawings.....	58



# CamLine

## Enclosed rotary cam switches and main switches

### Ordering details

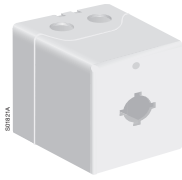

OTC4\_M25



OTC36NPT3/4

### Enclosed cam switches

The type and the ordering number are for one piece. Neutral and ground terminal, included.

Number of poles	Function	Size of <sup>1)</sup> enclosure	Catalogue number	List price
<b>ON-OFF switches, IP65, NEMA 4X</b>				
1	0 - 1	160x100x80	ONA1EPB	
2	0 - 1	160x100x80	ONA2EPB	
3	0 - 1	160x100x80	ONA3EPB	
4	0 - 1	160x100x80	ONA4EPB	
<b>ON - OFF switches, padlockable handle, IP65, NEMA 4X</b>				
1	0 - 1	160x100x80	ONA1EZB	
2	0 - 1	160x100x80	ONA2EZB	
3	0 - 1	160x100x80	ONA3EZB	
4	0 - 1	160x100x80	ONA4EZB	
<b>ON - OFF switches, key type, IP54, NEMA 1</b>				
1	0 - 1	160x100x80	ONA1EKB	
3	0 - 1	160x100x80	ONA3EKB	
<b>Change-over switches</b>				
1	1 - 0 - 2	160x100x80	ONU1EPB	
2	1 - 0 - 2	160x100x80	ONU2EPB	
<b>Reversing switches</b>				
3	1 - 0 - 2	160x100x80	ONW3EPB	

### Enclosures

The enclosures can accommodate cam switches for door mounting and OT-switches for door mounting and base mounting. Neutral and earth terminal, included.

Suitable cam switches	Protection - Class	Size of enclosure	Catalogue number	List price
<b>ON-OM: 10 contacts, 5 stages, OL40: 6 contacts, 3 stages</b>				
Enclosure	IP 65	96x96x108	OTC46M25	
<b>ON-OM: 6 contacts, 3 stages, wide, OL: 4 contacts, 2 stages</b>				
Enclosure	NEMA 4X	160x100x80	OTC36NPT3/4	
Mounting plate require for assembly of base mounted OT16...32E			VP3G6	

<sup>1)</sup> The height without handle.  
Special enclosed cam switches configured by the Camweb tool.



# CamLine

## Enclosed rotary cam switches

### Dimension drawings

#### OTC36NPT3/4

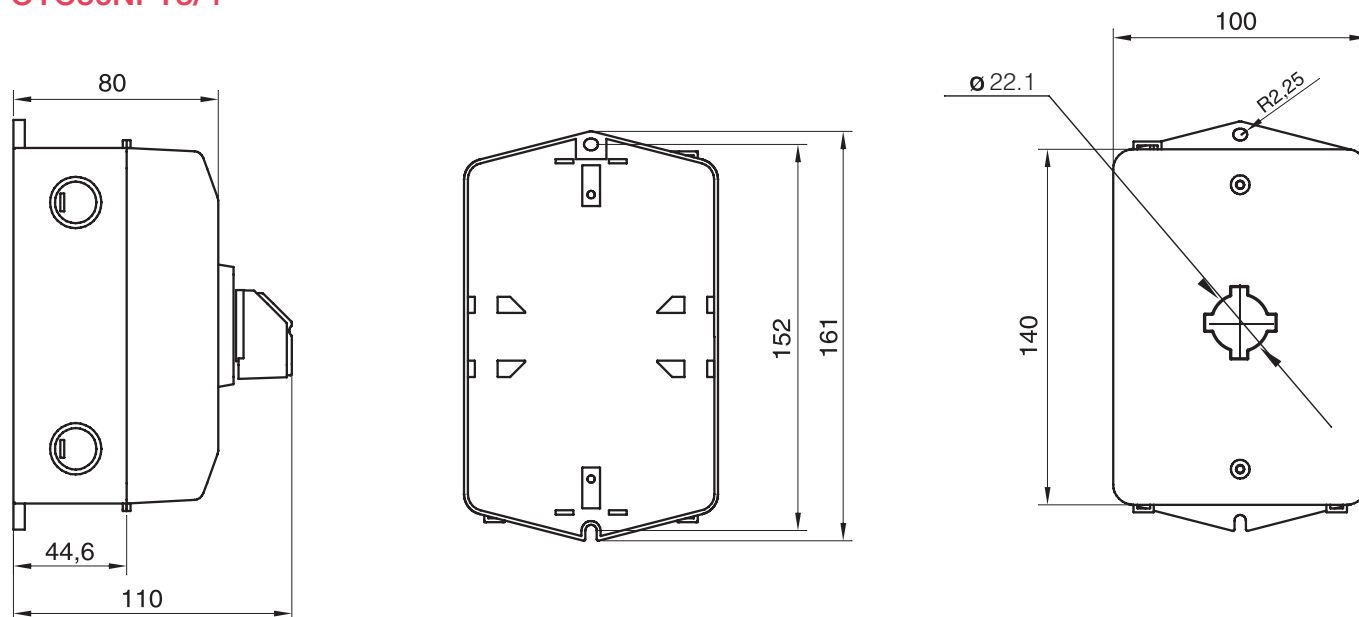

S01927A

#### OTC46M25

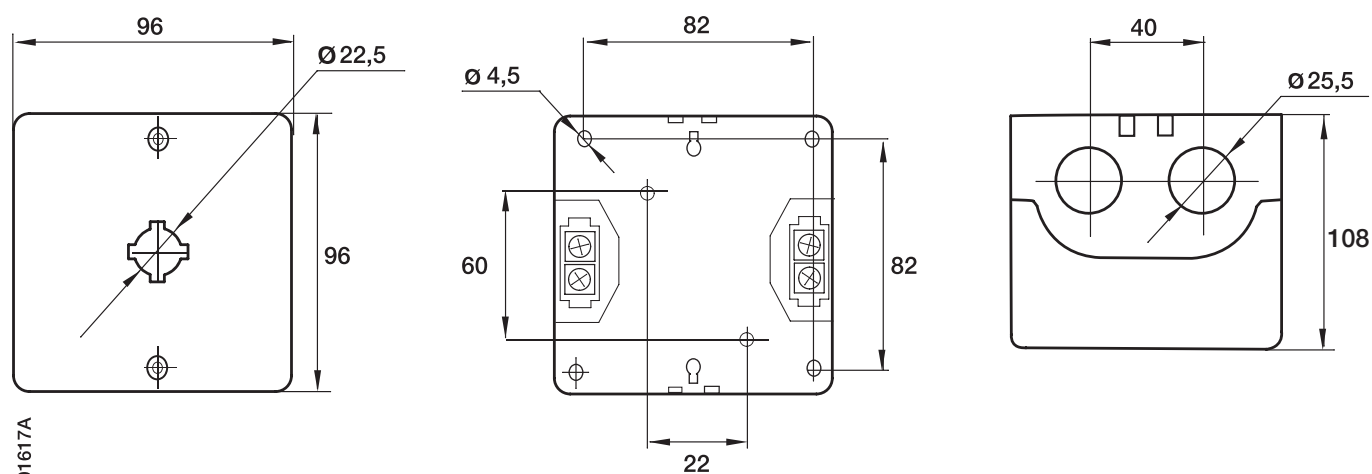

S01617A



