

**Accessories**

- > Standard Mounting Pads
- > Standard Clips
- > Alignment Pads
- > Stanchion Pads
- > Mounting Kits
- > Card Ejectors
- > Insulating Shoulder Washers

- > Request a Sample
- > Request a Quote
- > Ask an Engineer

# Standard Mounting Pads

Prevent heat damage during soldering  
 Facilitate board clean-up  
 Prevent solder bridges  
 Assure uniform device height

**Make a Selection**

**Part**

	<b>7717-4DAPG</b> <b>Material:</b> Diallyl Phthalate <b>Leads:</b> 4 <b>Diameter:</b> 9.53 <b>Thickness:</b> 1.91	
	<b>7717-79NG</b> <b>Material:</b> Nylon <b>Leads:</b> 3 <b>Diameter:</b> 9.02 <b>Thickness:</b> 0.97	
	<b>7717-178NG</b> <b>Material:</b> Nylon <b>Leads:</b> 3 <b>Diameter:</b> 8.89 <b>Thickness:</b> 0.53	
	<b>7717-5NG</b> <b>Material:</b> Nylon <b>Leads:</b> 4 <b>Diameter:</b> 8.89 <b>Thickness:</b> 3.18	
	<b>7717-22NG</b> <b>Material:</b> Nylon <b>Leads:</b> 3 <b>Diameter:</b> 8.71 <b>Thickness:</b> 1.91	
	<b>7717-94NG</b> <b>Material:</b> Nylon <b>Leads:</b> 4-Mar <b>Diameter:</b> 8.89 <b>Thickness:</b> 0.97	

	<p><b>7717-4NG</b>  Material: Nylon  Leads: 4  Diameter: 9.53  Thickness: 1.91</p>	
	<p><b>7717-5DAPG</b>  Material: Diallyl Phthalate  Leads: 4  Diameter: 8.89  Thickness: 3.18</p>	
	<p><b>7717-3DAPG</b>  Material: Diallyl Phthalate  Leads: 4-Mar  Diameter: 8.71  Thickness: 1.91</p>	
	<p><b>7717-15NG</b>  Material: Nylon  Leads: 4  Diameter: 8.89  Thickness: 0.51</p>	
	<p><b>7717-178DAPG</b>  Material: Diallyl Phthalate  Leads: 3  Diameter: 8.89  Thickness: 0.53</p>	
	<p><b>7717-15DAPG</b>  Material: Diallyl Phthalate  Leads: 4  Diameter: 8.89  Thickness: 0.51</p>	
	<p><b>7717-167NG</b>  Material: Nylon  Leads: 3  Diameter: 8.71  Thickness: 3.18</p>	
	<p><b>7717-86NG</b>  Material: Nylon  Leads: 3  Diameter: 8.71  Thickness: 1.91</p>	

**Part**

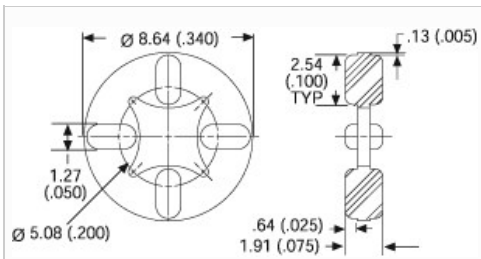

**7717-3NG**  
**Material:** Nylon  
**Leads:** 4-Mar  
**Diameter:** 8.71  
**Thickness:** 1.91

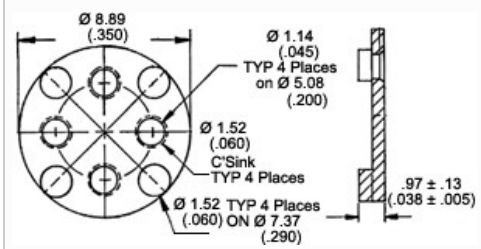

**7717-131DAPG**  
**Material:** Diallyl Phthalate  
**Leads:** 4  
**Diameter:** 8.89  
**Thickness:** 0.97

[Request a Quote](#)

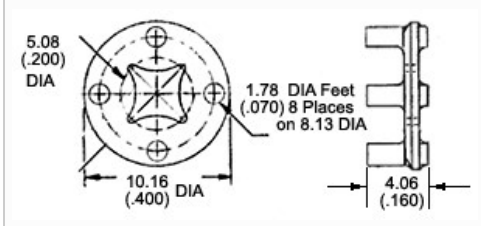

**7717-238NG**  
**Material:** Nylon  
**Leads:** 4-Mar  
**Diameter:** 10.16  
**Thickness:** 4.06

[Request a Quote](#)

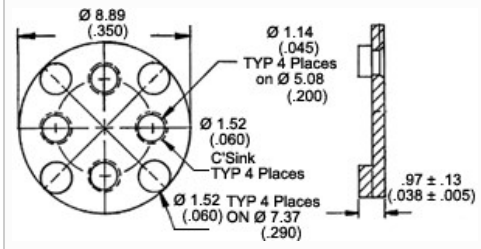

**7717-131NG**  
**Material:** Nylon  
**Leads:** 4  
**Diameter:** 8.89  
**Thickness:** 0.97

[Request a Quote](#)

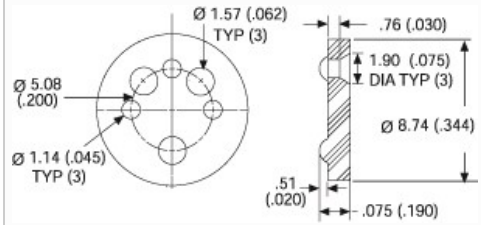

**7717-86DAPG**  
**Material:** Diallyl Phthalate  
**Leads:** 3  
**Diameter:** 8.71  
**Thickness:** 1.91

[Request a Quote](#)

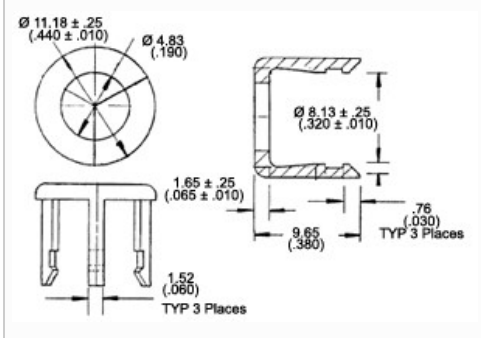

**7717-300NG**  
**Material:** Nylon  
**Leads:** Universal  
**Diameter:** 11.18  
**Thickness:** 9.65

[Request a Quote](#)

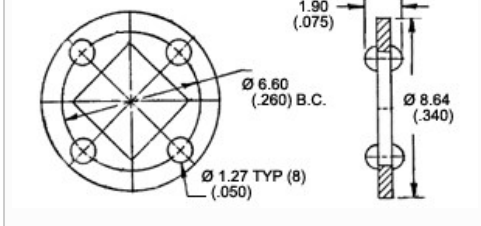

**7717-161DAPG**  
**Material:** Diallyl Phthalate  
**Leads:** 4-Mar  
**Diameter:** 8.64  
**Thickness:** 1.91

[Request a Quote](#)

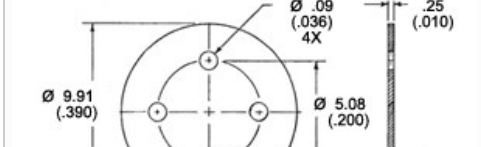

**7717-158TG**  
**Material:** Teflon  
**Leads:** 4  
**Diameter:** 9.91  
**Thickness:** 0.25

[Request a Quote](#)

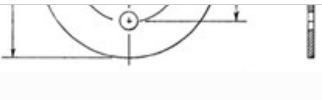
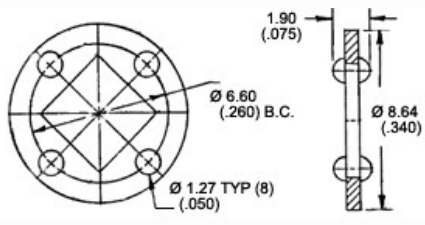
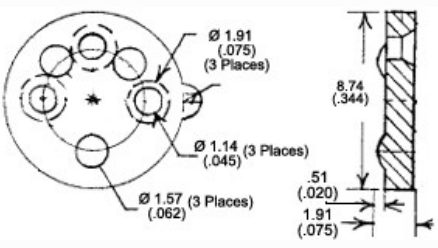
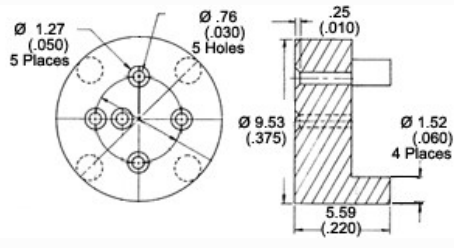
		
	<p><b>7717-161NG</b>  Material: Nylon  Leads: 4-Mar  Diameter: 8.64  Thickness: 1.91</p>	Request a Quote
	<p><b>7717-22DAPG</b>  Material: Diallyl Phthalate  Leads: 3  Diameter: 8.71  Thickness: 1.91</p>	Request a Quote
	<p><b>7717-159NG</b>  Material: Nylon  Leads: 5  Diameter: 9.53  Thickness: 5.59</p>	Request a Quote

1

2

next &gt;

last »

## Customer Assistance

- Contact Us
- Get Design Assistance
- Find a Distributor
- Find a Sales Rep
- Request a Quote
- Placing an Order
- Terms and Conditions
- Returns

## Popular Products

- Fans
- Extrusions
- Board Level
- Liquid Cooling
- Heat Pipe Technology
- Heat Sink Accessories
- Interface Materials

## Our Company

- News and Events
- Management Team
- Worldwide Locations
- Disclaimer
- Customer Survey
- Privacy Policy
- Careers

## Connect with Aavid

Like / Follow / Connect



© Copyright 2016 Aavid Thermalloy, LLC.