

Product Data Sheet 6312/2MP-204

**ebmpapst**

Die Wahl der Ingenieure



# 6312/2MP-204

## INDEX

<b>1</b>	<b>General</b> .....	<b>3</b>
<b>2</b>	<b>Mechanics</b> .....	<b>3</b>
2.1	General .....	3
2.2	Connections .....	3
<b>3</b>	<b>Operating Data</b> .....	<b>5</b>
3.1	Operating Data - Electrical Interface - Input .....	5
3.2	Electrical Operating Data .....	6
3.3	Operating Data - Electrical Interface - Output .....	7
3.4	Electrical Features .....	8
3.5	Aerodynamics .....	9
3.6	Sound Data .....	10
<b>4</b>	<b>Environment</b> .....	<b>10</b>
4.1	General .....	10
4.2	Climatic Requirements*) .....	10
<b>5</b>	<b>Safety</b> .....	<b>11</b>
5.1	Electrical Safety .....	11
5.2	Approval Tests .....	11
<b>6</b>	<b>Reliability</b> .....	<b>11</b>
6.1	General .....	11

**1 General**

Fan type	Axial fan	
Rotating direction looking at rotor	Counterclockwise	
Airflow direction	Air outlet over struts	
Bearing system	Ball bearing	
Mounting position	Any	

**2 Mechanics****2.1 General**

Depth	51,0 mm	
Diameter	172,0 mm	
Mass	0,825 kg	
Housing material	Metal	
Impeller material	Plastic	
Max. torque when mounted across both mounting flanges	wire outlet corner: 600 Ncm remaining corners: 600 Ncm	
Screw size	ISO 4762 - M4 degreased, without an additional brace and without washer	

**2.2 Connections**

Electrical connection	Wires	
Lead wire length	L = 365 mm	
Tolerance	+ - 10,0 mm	
Tube length	S = 10 mm	
Tolerance	+ - 2,0 mm	
Wire size (AWG)	22	
Insulation diameter	1,7 mm	
Contact	See drawing	

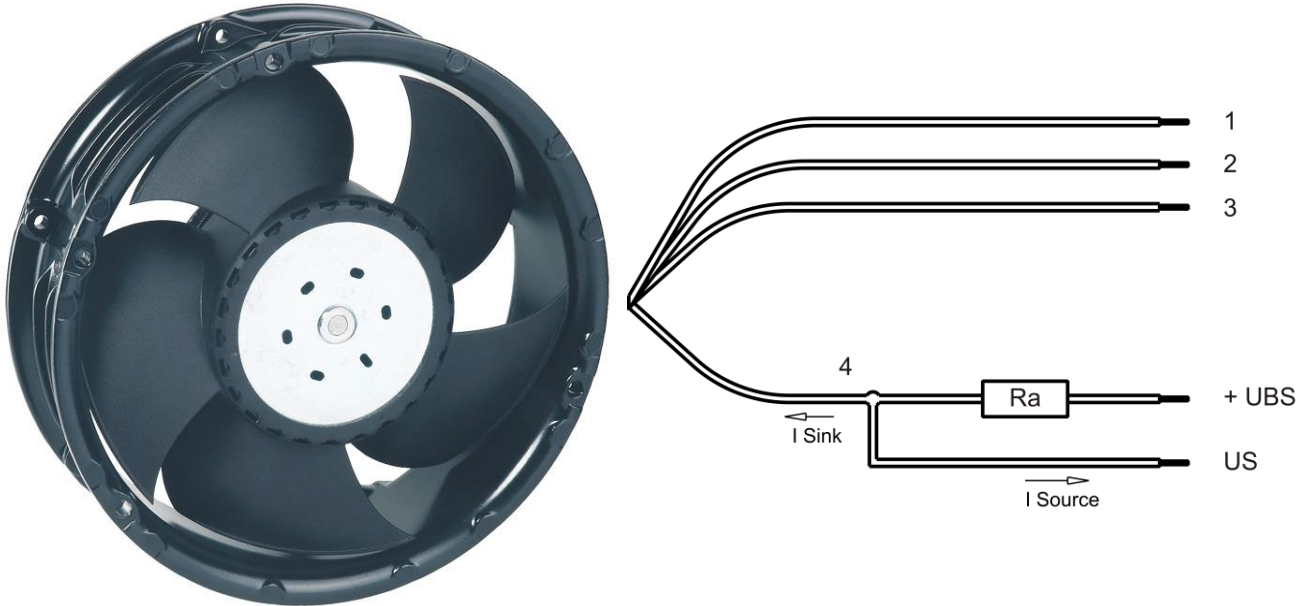

	Colour	Operation
Wire 1	red	+ UB
Wire 2	blue	- GND
Wire 3	violet	PWM
Wire 4	white	Tacho

The auxiliaries shown on the schematic diagram (which are required for the intended use) are not part of our delivery.

### 3 Operating Data

#### 3.1 Operating Data - Electrical Interface - Input

Control input	PWM
---------------	-----

#### Features

Input type	Open collector	
PWM - Frequency		1 kHz - 20 kHz Typical: 2 kHz

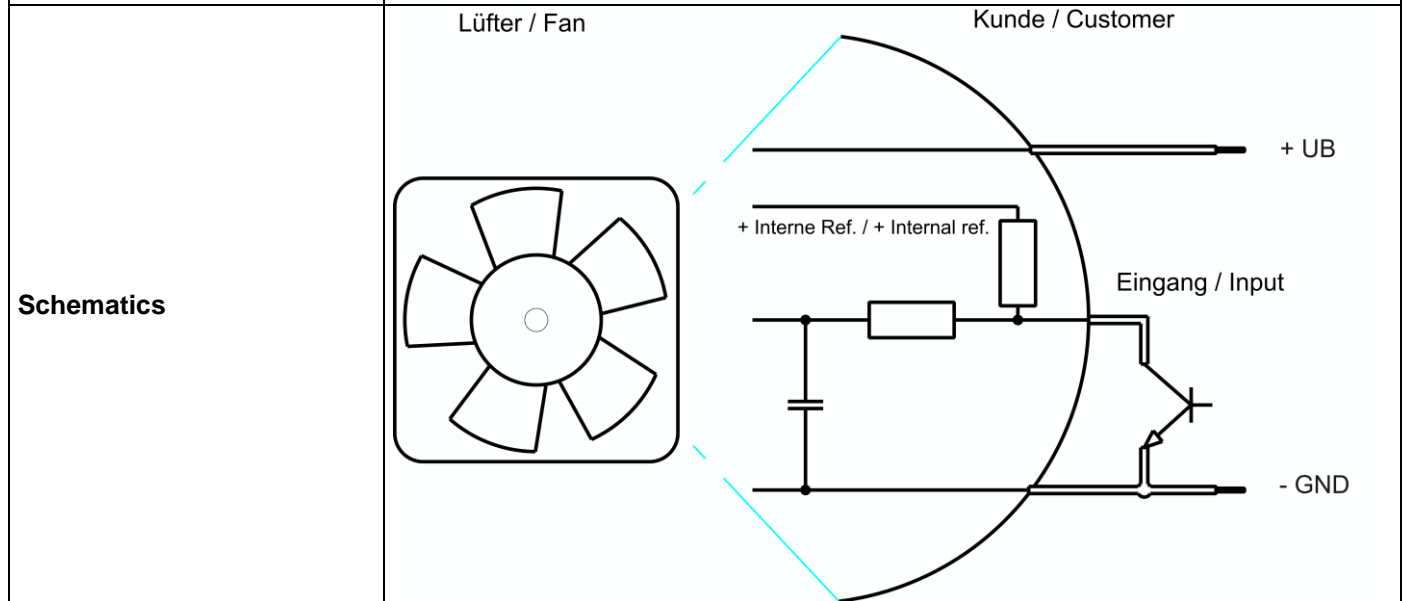
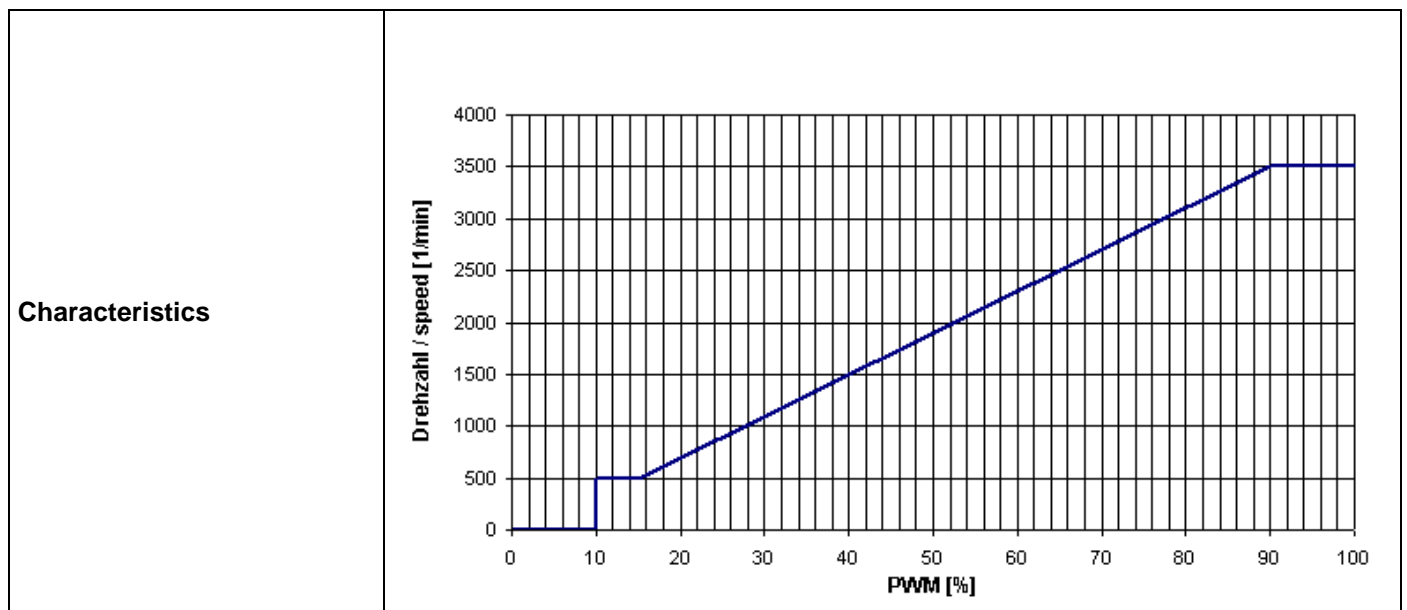

**3.2 Electrical Operating Data**

Measurement conditions: Normal air density = 1,2 kg/m<sup>3</sup>; Temperature 23°C +/- 3°C; Motor axis horizontal; warm-up time before measuring 5 minutes (unless otherwise specified). In the intake and outlet area should not be any solid obstruction within 0,5 m.

$\Delta p = 0$ : corresp. to free air flow (see section 3.5)  
 I: corresp. to arithm. mean current value

Name	Condition
PWM 0001	PWM: 100 %; f: 2 kHz

Features	Condition	Symbol	Values		
Voltage range	$\Delta p = 0$	U	8,0 V		16,0 V
Nominal voltage	$\Delta p = 0$	$U_N$		12,0 V	
Power consumption	$\Delta p = 0$	P	6,64 W	14,4 W	14,08 W
Tolerance	PWM 0001		+/- 17,5 %	+/- 15,0 %	+/- 15,0 %
Current consumption	$\Delta p = 0$	I	830 mA	1.200 mA	880 mA
Tolerance	PWM 0001		+/- 17,5 %	+/- 15,0 %	+/- 15,0 %
Speed	$\Delta p = 0$	n	2.400 1/min	3.500 1/min	3.500 1/min
Tolerance	PWM 0001		+/- 12,5 %	+/- 5,0 %	+/- 5,0 %

Name	Condition
PWM 0002	PWM: 50 %; f: 2 kHz

Features	Condition	Symbol	Values		
Voltage range	$\Delta p = 0$	U	8,0 V		16,0 V
Nominal voltage	$\Delta p = 0$	$U_N$		12,0 V	
Power consumption	$\Delta p = 0$	P	3,52 W	3,6 W	3,84 W
Tolerance	PWM 0002		+/- 15,0 %	+/- 15,0 %	+/- 15,0 %
Current consumption	$\Delta p = 0$	I	440 mA	300 mA	240 mA
Tolerance	PWM 0002		+/- 15,0 %	+/- 15,0 %	+/- 15,0 %
Speed	$\Delta p = 0$	n	1.900 1/min	1.900 1/min	1.900 1/min
Tolerance	PWM 0002		+/- 5,0 %	+/- 5,0 %	+/- 5,0 %

3.3 Operating Data - Electrical Interface - Output

Tacho type	/2 (open collector)
------------	---------------------

Signal-Ausgangsspannung / Signal output voltage

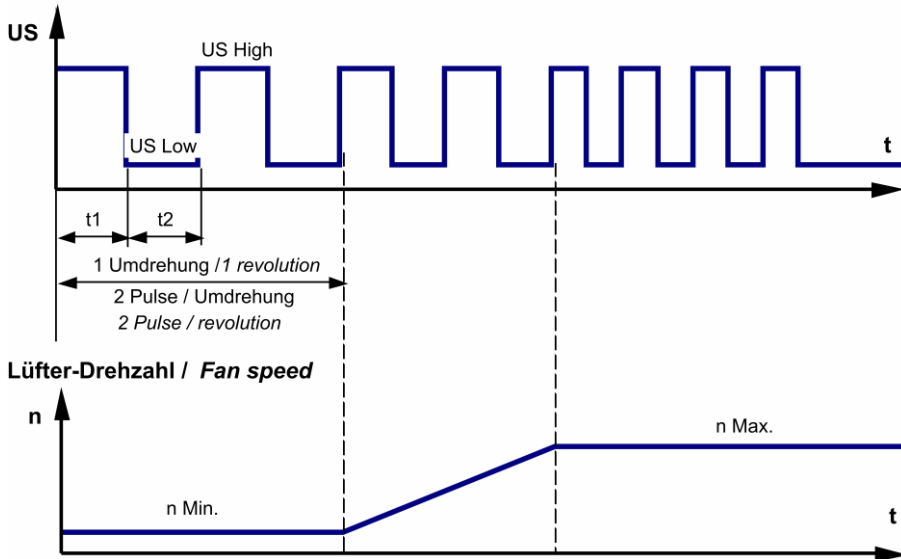

$$R_a = \frac{U_{BS} - US_{Low}}{I_{Sink}}$$

Features	Note	Values
Tacho operating voltage (UBS)		<= 60,0 V
Tacho signal Low	I sink: 2 mA	<= 0,4 V
Maximum sink current		<= 20 mA
External resistor	External resistor Ra from UBS to US required. All voltages measured to GND.	
Tacho frequency	(2 x n) / 60	
Tacho isolated from motor	No	
Slew rate		=> 0,5 V/us

Alarm type	None
------------	------

### 3.4 Electrical Features

Electronic function	Speed-Controlled	
Reversed polarity protection Max. residual current at $U_n$	Rectifying diode $I_F \leq 5 \text{ mA}$	
Locked rotor protection	Auto restart	
Locked rotor current at $U_n$	approx. 2.000 mA	
Clock signal $t_3/t_4$ at locked rotor	Typical: 0,5 s / 10,0 s	

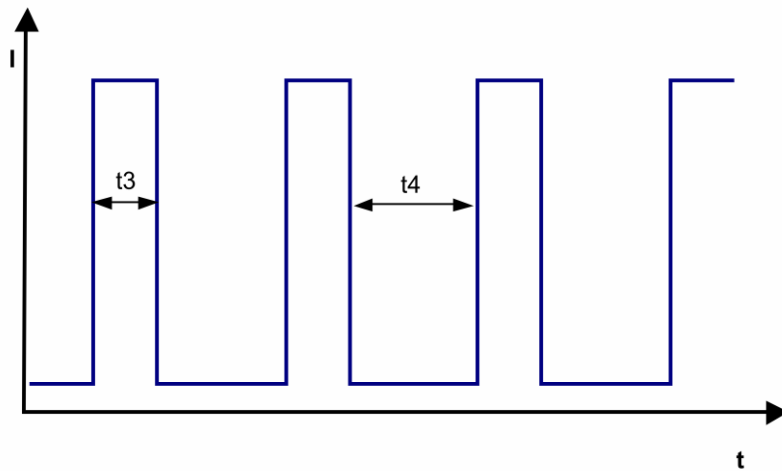



### 3.5 Aerodynamics

Measurement conditions: Measured with a double chamber intake rig acc. to DIN EN ISO 5801.  
 Normal air density = 1,2 kg/m<sup>3</sup>; Temperature 23°C +/- 3°C;  
 In the intake and outlet area should not be any solid obstruction within 0,5 m.  
 The information is only valid under the specified test conditions and may be changed by the installation conditions. If there are deviations from the standard test conditions, the characteristic values must be checked under the installed conditions.

a.) Operation condition:

3.500 1/min at free air flow	PWM 100 %; f: 2 kHz		
------------------------------	---------------------	--	--

Max. free-air flow ( $\Delta p = 0 / \dot{V} = \text{max.}$ )	360,0 m <sup>3</sup> /h	
Max. static pressure ( $\Delta p = \text{max.} / \dot{V} = 0$ )	206 Pa	

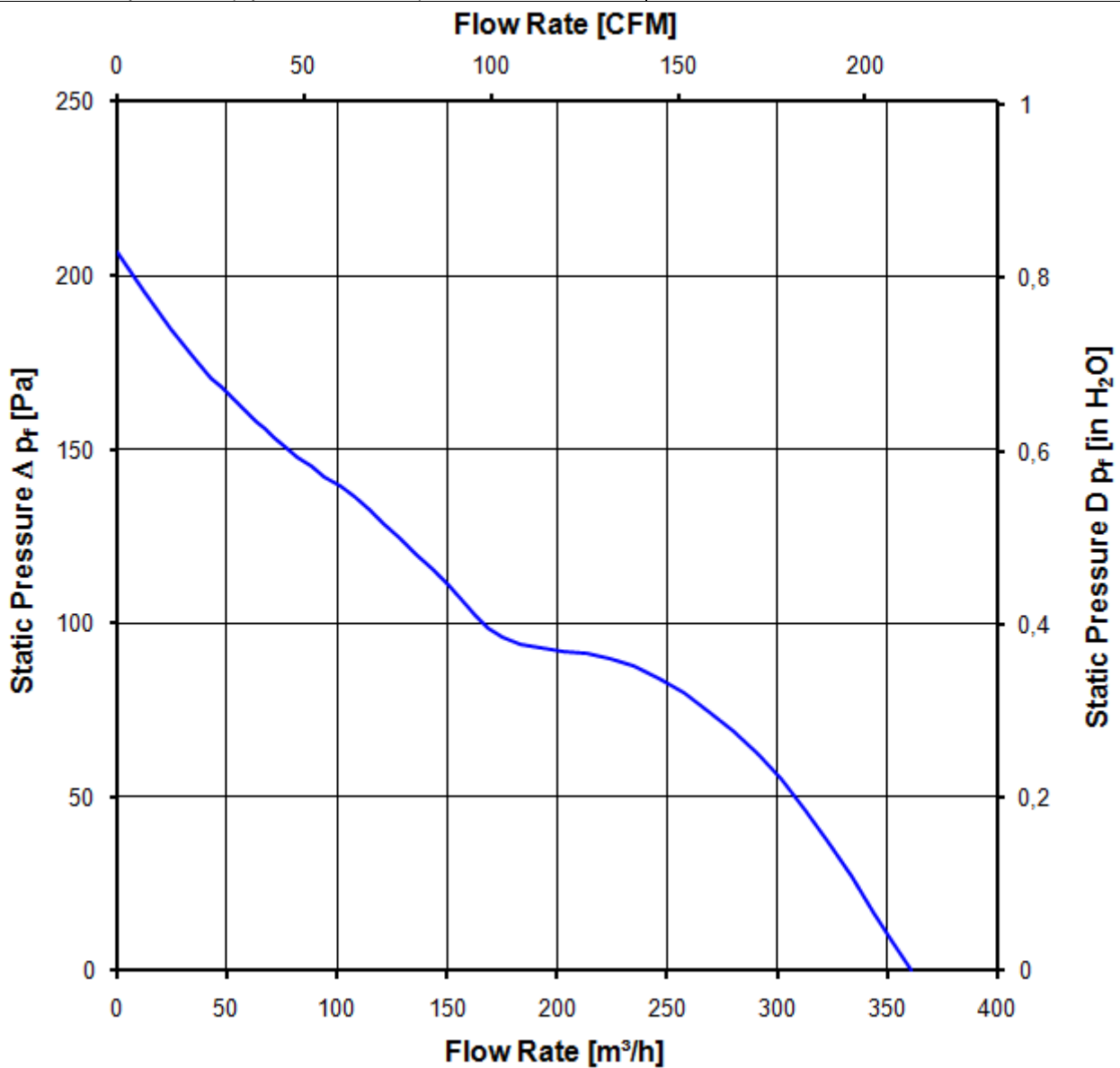

**3.6 Sound Data**

Measurement conditions: Sound pressure level: 1 Meter distance between microphone and the air intake.  
 Sound power level: Acc. to DIN 45635 part 38 (ISO 10302)  
 Measured in a semianchoic chamber with a background noise level of  $L_p(A) < 5 \text{ dB(A)}$   
 For further measurement conditions see section 3.5

a.) Operation condition:

3.500 1/min at free air flow	PWM 100 %; f: 2 kHz	PWM min.:	PWM max.:
Optimal operating point	tbd		
Sound power level at the optimal operating point	tbd		
Sound pressure level at free air flow, measured in rubber bands	49,0 dB(A)		

**4 Environment**

**4.1 General**

Min. permitted ambient temperature TU min.	-20 °C	
Max. permitted ambient temperature TU max.	65 °C	
Min. permitted storage temperature TL min.	-40 °C	
Max. permitted storage temperature TL max.	80 °C	

**4.2 Climatic Requirements \*)**

Humidity requirements	humid heat, constant; according to DIN EN 60068-2-78, 14 days	
Water exposure	None	
Dust requirements	None	
Salt fog requirements	None	

\*) Permitted application area:

The product is intended for use in sheltered rooms with controlled temperature and controlled humidity. Directly exposure to water must be avoided.

Pollution degree 1 (according DIN EN 60664-1)

There is either no pollution or it occurs only dry, non-conductive pollution. The pollution has no negative impact.

## 5 Safety

### 5.1 Electrical Safety

Dielectric strength DIN EN 60950 (VDE 0805) and DIN EN 60335 (VDE 0700) A.) Type test Measuring conditions: After 48h of storage at 95% R.H. and 25°C. No arcing or breakdown is allowed! All connections together to ground.	500 VAC / 1 Min.	
B.) Routine test Measuring conditions: At indoor climate. No arcing or breakdown is allowed! All connections together to ground.	500 VAC / 1 Sec.	
Isolation resistance Measuring conditions: After 48h of storage at 95% R.H. and 25°C measured with U=500 VDC for 1 min.	RI > 10 MOhm	
clearance / creepage distance	1,0 mm / 1,2 mm	
Protection class	III	

### 5.2 Approval Tests

CE	EC Declaration of Conformity	No
EAC	Eurasian Conformity	Yes
UL	Underwriters Laboratories	Yes / UL507, Electric Fans
VDE	Association for Electrical, Electronic and Information Technologies	Yes / Approval acc. to EN 60950 (VDE 0805) - Information technology equipment
CSA	Canadian Standards Association	Yes / C22.2 No. 113 Fans and Ventilators
CCC	China Compulsory Certification	No

## 6 Reliability

### 6.1 General

Life expectancy L10 at TU = 40 °C	82.500 h	
Life expectancy L10 IPC at TU = 40 °C	140.000 h	

Drawing of this component, its parts and their dimensions are the property of the manufacturer. It is not to be used for the production of other components without the written consent of the manufacturer.

Zeichnung ist Eigentum der Firma ebmpapst. Sie ist nicht für die Herstellung anderer Bauteile ohne schriftliche Genehmigung der Firma ebmpapst zu verwenden.

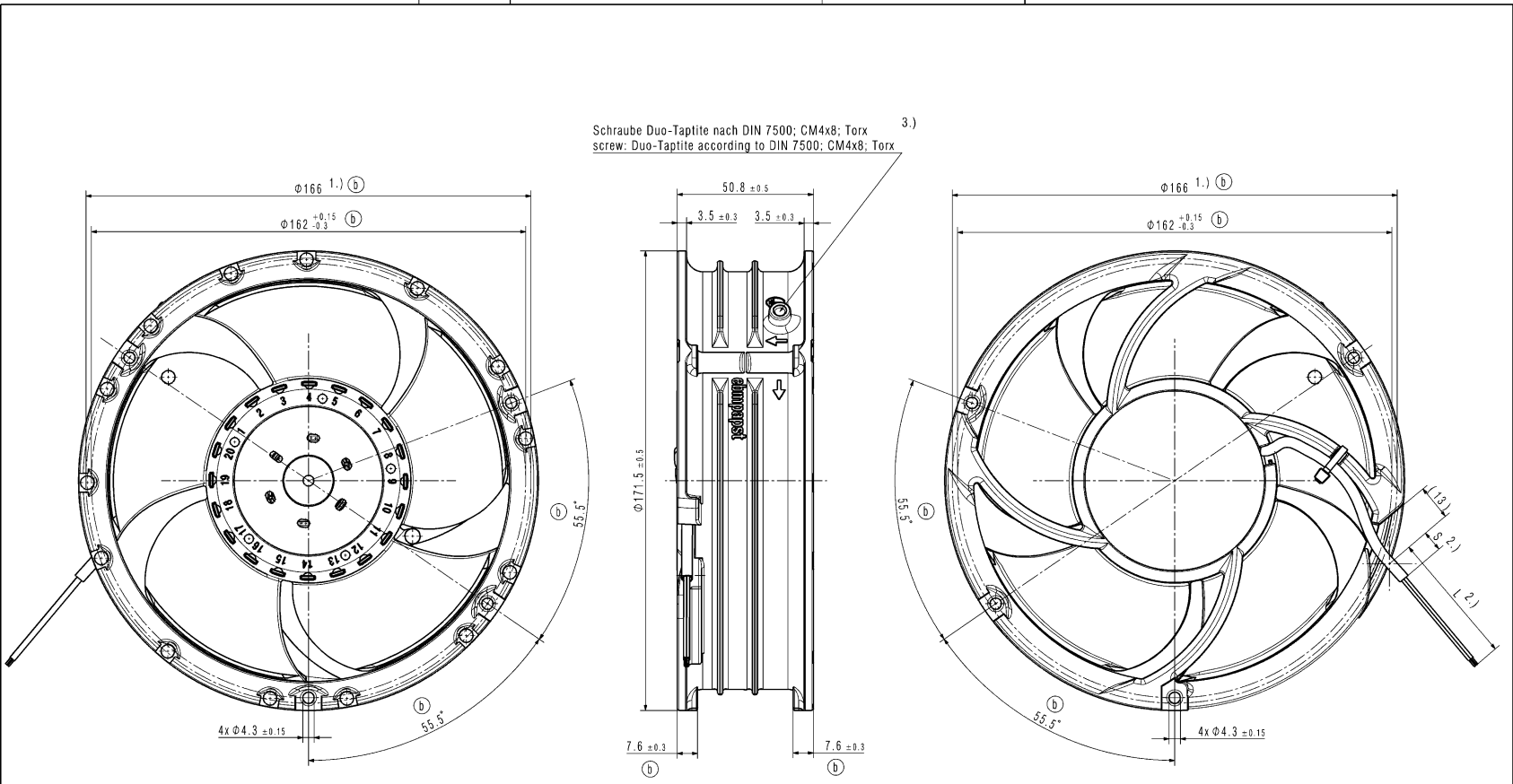

3.) Schraube Duo-Taprite nach DIN 7500; CM4x8; Torx  
 screw: Duo-Taprite according to DIN 7500; CM4x8; Torx

- 1.) Maße aus Montageausschnitt
- 2.) Anzahl und Länge der Litzen/Schlauch siehe Produktspezifikation
- 3.) Nur wenn in Stückliste enthalten

- Axialspiel der Kugellager mit Feder spielfrei gelagert

- 1.) measures of mounting cut out
- 2.) length an number of wires/tube see product specification
- 3.) only it is included in bill of material

- ball bearing without clearance by a pre-load spring

MP-Steuerflansch	Doc. Nr. / Drawing No.	DATA SYSTEMS (UK) LTD DATA SYSTEMS (UK) LTD	Doc. No. / Drawing No.	Revisions- / Änderungs- Liste / Rev. List	Revisions- / Änderungs- Liste / Rev. List
		98984901 09/000		Artikel / Part No.	
Filteranlagung / Filtermount	Ø	Ø-Referenzmaß / Ø-Reference dimension	Da / Diameter	Zeichn.-Nr. / Drawing No.	Blatt- / Page No.
Allgemeinabmessungen / Gen. Dimensions				Blatt- / Page No.	Revisions- / Änderungs- Liste / Rev. List
<b>ebmpapst</b>			ebmpapst, St. Georgen, 50869 St. Georgen, D-50869 St. Georgen		