



The engineer's choice

ebmpapst

4656 EZU

INDEX

1 General..... 3

2 Mechanics..... 3

2.1 GENERAL 3

2.2 CONNECTIONS..... 4

3 Operating Data 5

3.1 ELECTRICAL OPERATING DATA..... 5

3.2 OPERATING DATA - ELECTRICAL INTERFACE -OUTPUT 6

3.3 ELECTRICAL FEATURES 6

3.4 AERODYNAMIC 7

3.5 SOUND DATA 8

4 Environment 9

4.1 GENERAL 9

4.2 CLIMATIC REQUIREMENTS*)..... 9

5 Safety 10

5.1 ELECTRICAL SAFETY..... 10

5.2 APPROVAL TESTS..... 10

6 Reliability 10

6.1 GENERAL 10

1 General

Fan type	Fan without chassis
Rotational direction looking at rotor	clockwise
Airflow direction	Air outlet over flange
Bearing system	Ball bearing
Mounting position	any
Balancing grade	2,5

2 Mechanics**2.1 General**

Width	0,0 mm	
Height	0,0 mm	
Depth	39,0 mm	
Diameter	108,0 mm	
Weight	0,380 kg	
Housing material		
Impeller material	Metal	

2.2 Connections

Electrical connection	Wires	
Length of lead wire	L = 375,0 mm	
Tolerance	+ - 10,0 mm	
Length of tube	see drawing	
Tolerance		
Wire gauge (AWG)	18	
Insulation diameter	2,06 mm	
Plug	see drawing	
Contact	see drawing	



	Colour	Operation
Wire 1	black	L
Wire 2	black	N

3 Operating Data

3.1 Electrical Operating Data

For checking purposes the electrical data can be specified without an intake nozzle / aperture plate as well. For this the data have to be defined by the appropriate quality assurance.

Electrical Operating Data with intake nozzle (For checking purposes)

Measurement conditions: Normal air density = 1,2 kg/m³; Temperature 23°C +/- 3°C; Motor axis horizontal; warm-up time before measuring 5 minutes (unless otherwise specified).
In the intake and outlet area should not be any solid obstruction within 0,5 m.

Measurement setup:	Measured with an aperture plate
Aperture plate diameter:	109 mm
Distance between mounting traverse and aperture plate:	20,5 mm

$\Delta p = 0$: corresp. to free air flow (see section 3.4)

I: corresp. to RMS line current

Features	Condition	Symbol	Values	
			50 Hz	60 Hz
Frequency	$\Delta p = 0$	f	50 Hz	60 Hz
Nominal voltage	$\Delta p = 0$	U_N	230,0 V	230,0 V
Tolerance			+ 6,0 % - 10,0 %	+ 6,0 % - 10,0 %
Power consumption	$\Delta p = 0$	P	19,0 W	18,0 W
Tolerance			+ - 10,0 %	+ - 10,0 %
Speed	$\Delta p = 0$	n	2.600 1/min	2.950 1/min
Tolerance			+ - 3,0 %	+ - 3,0 %

3.2 Operating Data - Electrical Interface -Output

Tacho type	None
------------	------

3.3 Electrical Features

Locked rotor protection	Impedance
Locked rotor current at U_n	

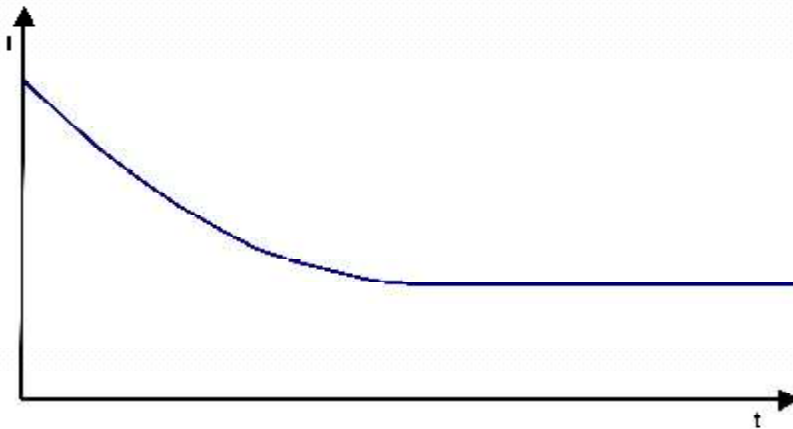

3.4 Aerodynamic

Measurement conditions: Measured with a double chamber intake rig acc. to DIN EN ISO 5801. Normal air density = 1,2 kg/m³; Temperature 23°C +/- 3°C; In the intake and outlet area should not be any solid obstruction within 0,5 m. The information is only valid under the specified test conditions and may be changed by the installation conditions. If there are deviations from the standard test conditions, the characteristic values must be checked under the installed conditions.

Measurement setup:	Measured with an aperture plate
Aperture plate diameter:	109 mm
Distance between mounting traverse and aperture plate:	20,5 mm

a.) Operation condition:

2.600 1/min at free air flow Frequency: 50 Hz

Max. free-air flow ($\Delta p = 0 / \dot{V} = \text{max.}$)	124,0 m ³ /h
Max. static pressure ($\Delta p = \text{max.} / \dot{V} = 0$)	72 Pa

b.) Operation condition:

2.950 1/min at free air flow Frequency: 60 Hz

Max. free-air flow ($\Delta p = 0 / \dot{V} = \text{max.}$)	142,0 m ³ /h
Max. static pressure ($\Delta p = \text{max.} / \dot{V} = 0$)	77 Pa

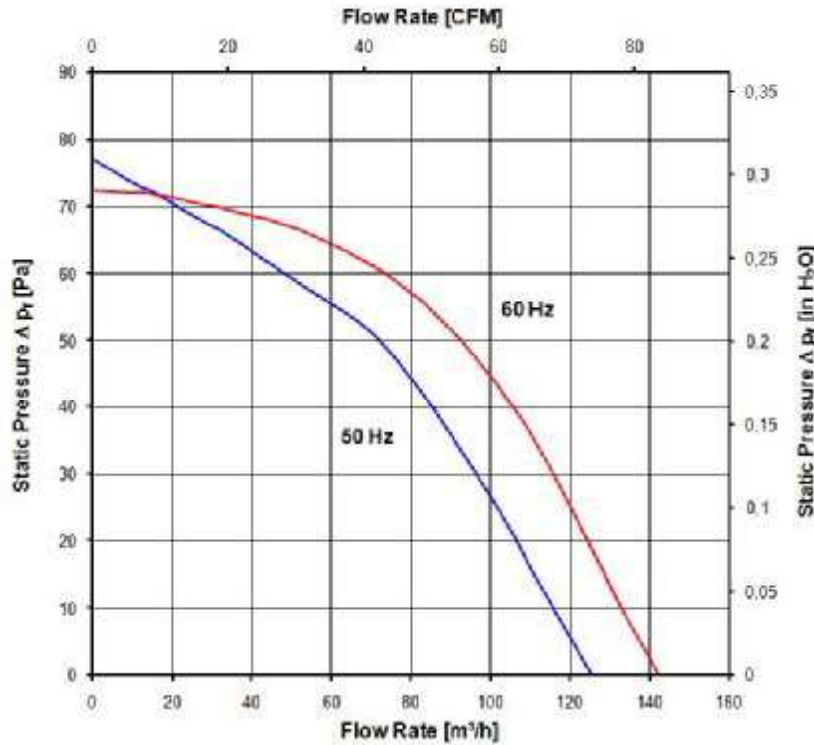

3.5 Sound Data

Measurement conditions: Sound pressure level: 1 Meter distance between microphone and the air intake.
 Sound power level: Acc. to DIN 45635 part 38 (ISO 10302)
 Measured in a semianchoic chamber with a background noise level of $L_p(A) < 5 \text{ dB(A)}$
 For further measurement conditions see section 3.4

a.) Operation condition:
 2.600 1/min at free air flow Frequency: 50 Hz

Optimal operating point		
Sound power level at the optimal operating point		
Sound pressure level at free air flow, measured in rubber bands	39,0 dB(A)	

b.) Operation condition:
 2.950 1/min at free air flow Frequency: 60 Hz

Optimal operating point		
Sound power level at the optimal operating point		
Sound pressure level at free air flow, measured in rubber bands	42,0 dB(A)	

4 Environment

4.1 General

Min. permitted ambient temperature TU min.	-40 °C / 50 Hz -40 °C / 60 Hz	
Max. permitted ambient temperature TU max.	65 °C / 50 Hz 70 °C / 60 Hz	
Min. permitted storage temperature TL min.	-40 °C	
Max. permitted storage temperature TL max.	80 °C	

4.2 Climatic requirements*)

IP-protection type (certified)	IP 55 **)	
Humidity requirements	humid temperature, cyclic; according to DIN EN 60068-2-38, 10 cycle and condensation water check; according to DIN EN ISO 6270-2, 14 days	
Radiation exposure	Solar radiation; according to DIN EN 60068-2-5	
Salt fog requirements	None	
Harmful gas requirements	None	

*) Permitted application area:

The product is for the use in partial sheltered rooms or open, roofed areas. Direct exposure to water is allowed provided that this does not prevent the normal operation. Saline ambient conditions must be avoided.

Pollution degree 3 (according DIN EN 60664-1)

It occurs conductive pollution or dry non-conductive pollution which becomes conductive due to condensation.

**) The specification of the IP protection refers to the conditions mentioned in certification of the fan. The above mentioned short description of the protection scope is not final. For detailed information of the respective protection scope and definitions, see certification as well as DIN EN 60529 (protection by housings) and ISO 20653 (for vehicles) with the letter K.

Short description of the IP-protection type:

Solid particle Protection: Protected against dust.

Protection against deliberate contact: Protected against contact to hazardous parts with a wire.

Protection against water: Protected against water jets.

5 Safety

5.1 Electrical Safety

Dielectric strength DIN EN 60950 (VDE 0805) and DIN EN 60335 (VDE 0700) A.) Type test Measuring conditions: After 48h of storage at 95% R.H. and 25°C. No arcing or breakdown is allowed! All connections together to ground. B.) Routine test Measuring conditions: At indoor climate. No arcing or breakdown is allowed! All connections together to ground.	1500 VAC / 1 Min. 1500 VAC / 1 Sec.
Isolation resistance Measuring conditions: After 48h of storage at 95% R.H. and 25°C measured with U=500 VDC for 1 min.	RI > 50 MOhm
clearance / creepage distance	2,0 mm / 1,8 mm
Protection class	I

5.2 Approval Tests

CE	Yes
UL	Yes / UL507, Electric Fans
VDE	Yes / Approval acc. to EN 60950 (VDE 0805) - Information technology equipment
CSA	No
CCC	Yes / GB 12350 Safety Requirements for small Power Motors

The approval tests are observed to:

U approval max.: 230 V / f: 60 Hz @ TU approval max.: 65 °C

6 Reliability

6.1 General

Life expectancy L10 at TU = 40 °C	37.500 h / 50 Hz	
Life expectancy L10 at TU max.	15.000 h / 50 Hz	

Copying of this document, and giving it to others, are the use or communication of the contents thereof, are forbidden without express authority. Offenders are liable to the payment of damages. All rights are reserved in the event of the grant of a patent or the registration of a utility model or design.

Schzeichnen nach DIN 24 beachten

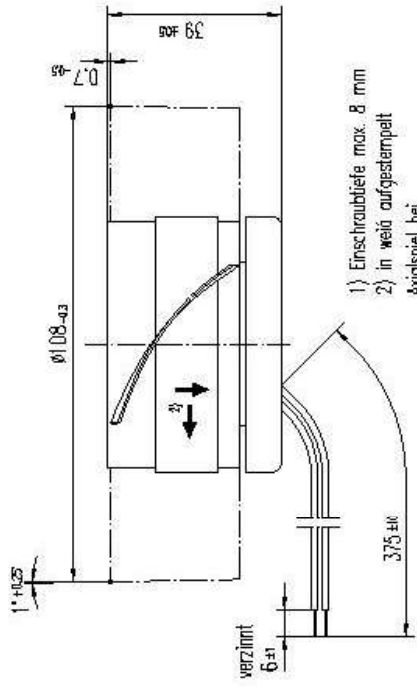
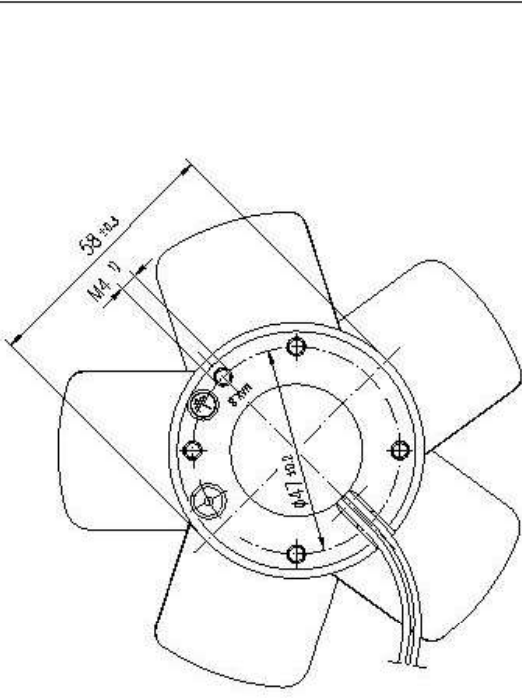

- 1) Einschraubtiefe max. 8 mm
 - 2) in wein aufgestempelt
- Axialspiel bei
- Kugellagerung (K): 0 (mit Federausgleich)
 - Gleitlagerung (G): 0.1 - 0.6

Allgemeinbezeichnung		DIN 2708 - mik		gilt für: 924 4014 942 (K) 4656 EZ 924 4014 945 (K) 4656 ZFR 924 4014 951 (G) 4680 EZ-951 ① 924 4014 007 (K) 4656 EZU	
084	210	232	235	240	516
Erstellung		Datum		Name	
Gepr.:		20.04.05		Kleininger	
Gepr.:		20.04.06		Wrobel G.	
Erhöhung 25.03.97		Kalebski		Kalebski	
Index: 2nd.-Hilf.		Datum: Festgelegt von		PAPST-MOTOREN GmbH & Co KG	
Zur Verwendung im Verteiler freigegeben		D-7812 St. Georgen		Germany	
von Kalebski, M. am 25.03.97					
Arbeitsstück				Axialfilter	
Material				1:1	
Zug.-Nr.				924 4014 942	
Ess./Zug.-				K-A/024-4014	
Blatt				2	